



322 1st Ave N, Suite #600
 Minneapolis, MN 55401
 phone 612.746.4260
 facsimile 612.746.4754
 www.jlgarchitects.com
 copyright © 2016

I HEREBY CERTIFY THAT THIS SURVEY, PLAN, OR REPORT WAS PREPARED BY ME OR UNDER MY DIRECT SUPERVISION AND THAT I AM A DULY LICENSED ENGINEER UNDER THE LAWS OF THE STATE OF MINNESOTA.

Thomas E. Anderson
 THOMAS E. ANDERSON
 44223 12.04.2017
 LIC. NO. DATE

REVISION SCHEDULE		
NO.	DESCRIPTION	DATE

JLG ARCHITECTS
BOTTINEAU RIDGE II APARTMENTS
 MAPLE GROVE, MN

DATE
12/04/2017

PHASE
100% CDs

PROJECT
16098

SHEET
C101
 EXISTING
 CONDITIONS

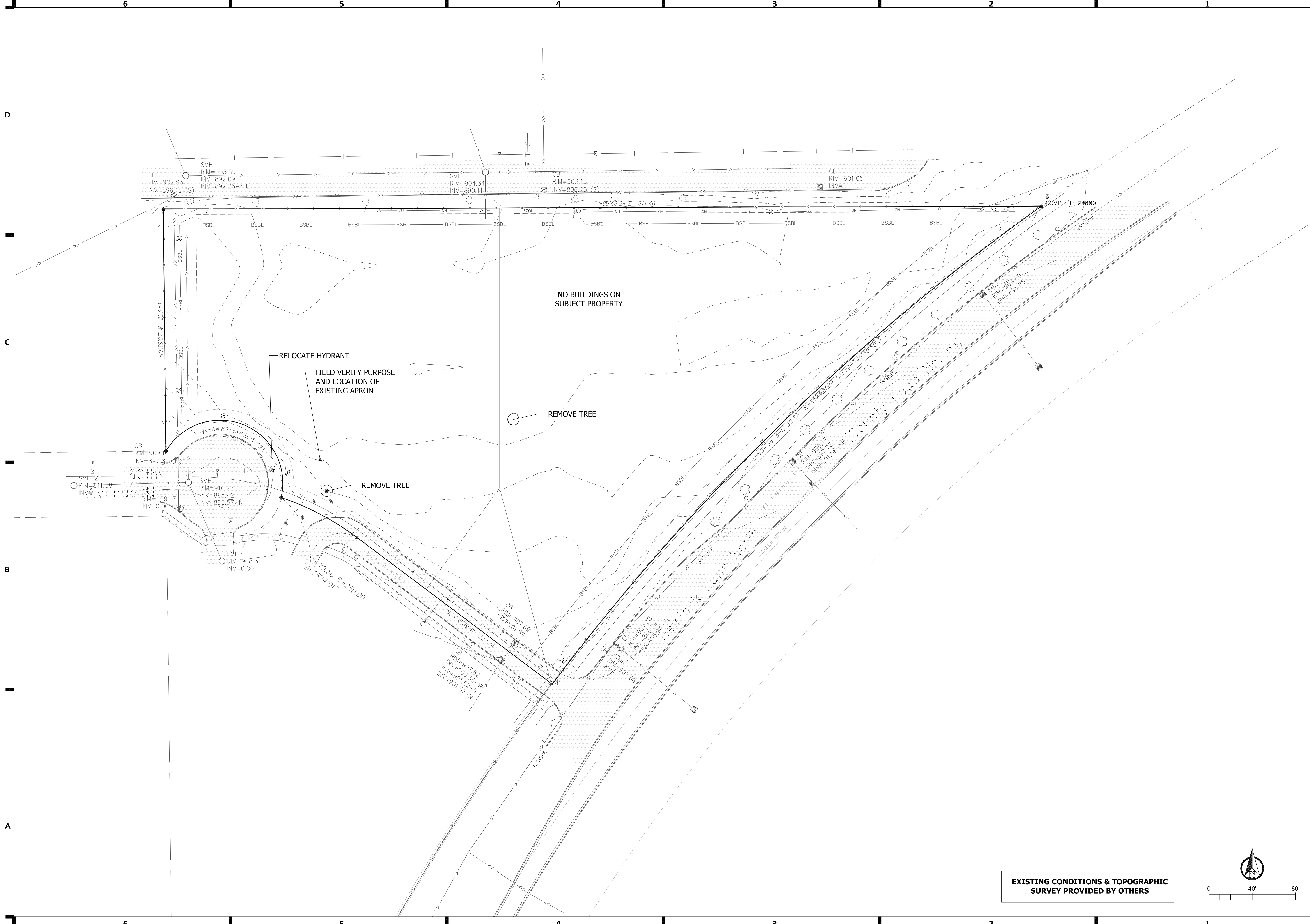

EXISTING CONDITIONS & TOPOGRAPHIC SURVEY PROVIDED BY OTHERS

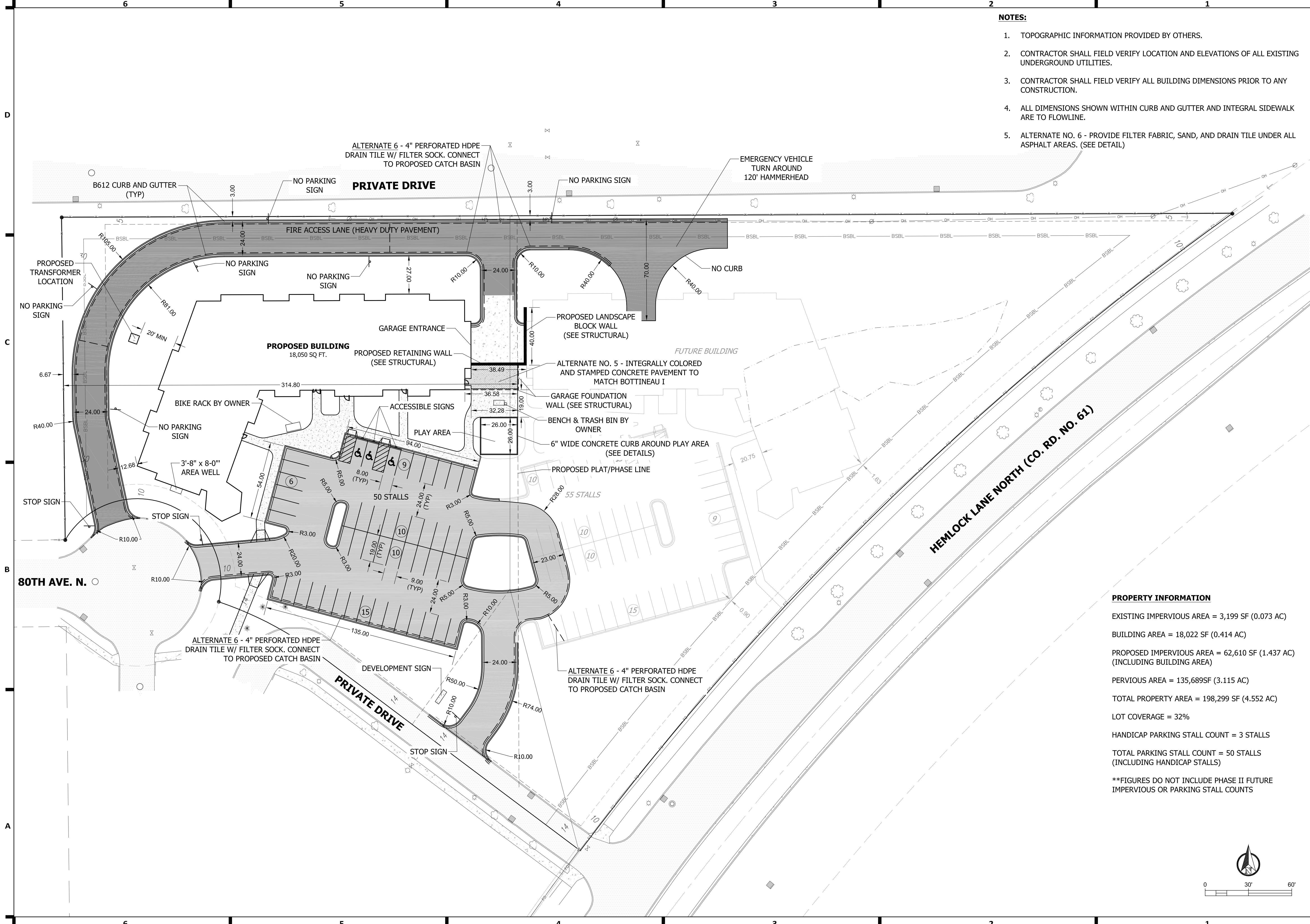

- NOTES:**
1. TOPOGRAPHIC INFORMATION PROVIDED BY OTHERS.
 2. CONTRACTOR SHALL FIELD VERIFY LOCATION AND ELEVATIONS OF ALL EXISTING UNDERGROUND UTILITIES.
 3. CONTRACTOR SHALL FIELD VERIFY ALL BUILDING DIMENSIONS PRIOR TO ANY CONSTRUCTION.
 4. ALL DIMENSIONS SHOWN WITHIN CURB AND GUTTER AND INTEGRAL SIDEWALK ARE TO FLOWLINE.
 5. ALTERNATE NO. 6 - PROVIDE FILTER FABRIC, SAND, AND DRAIN TILE UNDER ALL ASPHALT AREAS. (SEE DETAIL)



322 1st Ave N, Suite #600
 Minneapolis, MN 55401
 phone 612.746.4260
 facsimile 612.746.4754
 www.jlgarchitects.com
 copyright © 2016

I HEREBY CERTIFY THAT THIS SURVEY, PLAN, OR REPORT WAS PREPARED BY ME OR UNDER MY DIRECT SUPERVISION AND THAT I AM A DULY LICENSED ENGINEER UNDER THE LAWS OF THE STATE OF MINNESOTA.

Thomas E. Anderson
 THOMAS E. ANDERSON
 48223 12.04.2017
 LIC. NO. DATE

REVISION SCHEDULE

NO.	DESCRIPTION	DATE

PROPERTY INFORMATION

EXISTING IMPERVIOUS AREA = 3,199 SF (0.073 AC)
 BUILDING AREA = 18,022 SF (0.414 AC)
 PROPOSED IMPERVIOUS AREA = 62,610 SF (1.437 AC) (INCLUDING BUILDING AREA)
 PERVIOUS AREA = 135,689SF (3.115 AC)
 TOTAL PROPERTY AREA = 198,299 SF (4.552 AC)
 LOT COVERAGE = 32%
 HANDICAP PARKING STALL COUNT = 3 STALLS
 TOTAL PARKING STALL COUNT = 50 STALLS (INCLUDING HANDICAP STALLS)

**FIGURES DO NOT INCLUDE PHASE II FUTURE IMPERVIOUS OR PARKING STALL COUNTS

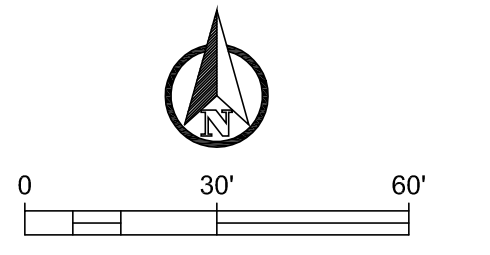

JLG ARCHITECTS
BOTTINEAU RIDGE II APARTMENTS
 MAPLE GROVE, MN

DATE
12/04/2017

PHASE
100% CDs

PROJECT
16098

SHEET
C201
 SITE PLAN

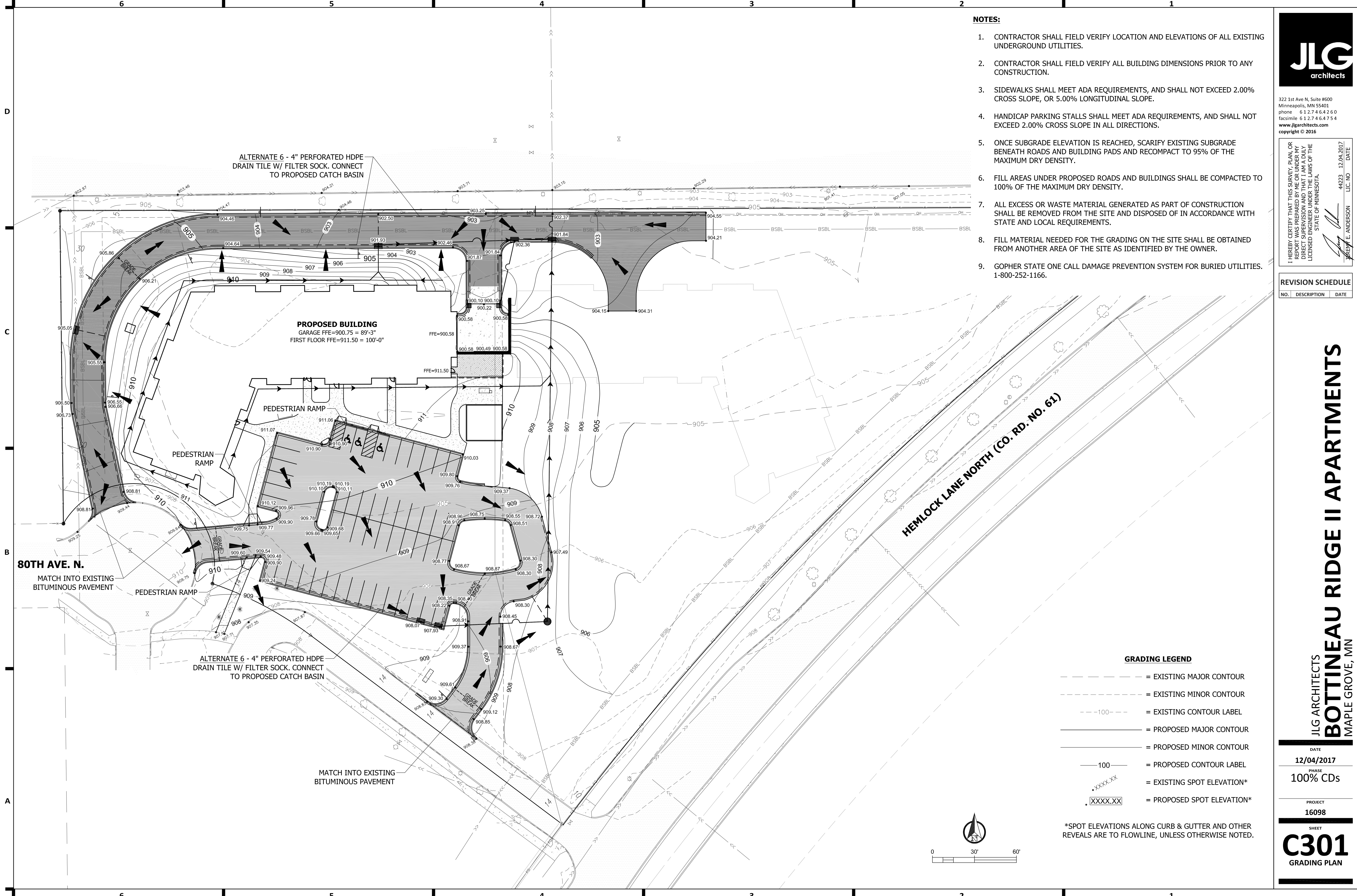

- NOTES:**
1. CONTRACTOR SHALL FIELD VERIFY LOCATION AND ELEVATIONS OF ALL EXISTING UNDERGROUND UTILITIES.
 2. CONTRACTOR SHALL FIELD VERIFY ALL BUILDING DIMENSIONS PRIOR TO ANY CONSTRUCTION.
 3. SIDEWALKS SHALL MEET ADA REQUIREMENTS, AND SHALL NOT EXCEED 2.00% CROSS SLOPE, OR 5.00% LONGITUDINAL SLOPE.
 4. HANDICAP PARKING STALLS SHALL MEET ADA REQUIREMENTS, AND SHALL NOT EXCEED 2.00% CROSS SLOPE IN ALL DIRECTIONS.
 5. ONCE SUBGRADE ELEVATION IS REACHED, SCARIFY EXISTING SUBGRADE BENEATH ROADS AND BUILDING PADS AND RECOMPACT TO 95% OF THE MAXIMUM DRY DENSITY.
 6. FILL AREAS UNDER PROPOSED ROADS AND BUILDINGS SHALL BE COMPACTED TO 100% OF THE MAXIMUM DRY DENSITY.
 7. ALL EXCESS OR WASTE MATERIAL GENERATED AS PART OF CONSTRUCTION SHALL BE REMOVED FROM THE SITE AND DISPOSED OF IN ACCORDANCE WITH STATE AND LOCAL REQUIREMENTS.
 8. FILL MATERIAL NEEDED FOR THE GRADING ON THE SITE SHALL BE OBTAINED FROM ANOTHER AREA OF THE SITE AS IDENTIFIED BY THE OWNER.
 9. GOPHER STATE ONE CALL DAMAGE PREVENTION SYSTEM FOR BURIED UTILITIES. 1-800-252-1166.



322 1st Ave N, Suite #600
 Minneapolis, MN 55401
 phone 612.746.4260
 facsimile 612.746.4754
 www.jlgarchitects.com
 copyright © 2016

I HEREBY CERTIFY THAT THIS SURVEY PLAN OR REPORT WAS PREPARED BY ME OR UNDER MY DIRECT SUPERVISION AND THAT I AM A DULY LICENSED ENGINEER UNDER THE LAWS OF THE STATE OF MINNESOTA.

THOMAS E. ANDERSON
 44223 12/04/2017
 L.I.C. NO. DATE

REVISION SCHEDULE

NO.	DESCRIPTION	DATE

HEMLOCK LANE NORTH (CO. RD. NO. 61)

80TH AVE. N.
 MATCH INTO EXISTING BITUMINOUS PAVEMENT

ALTERNATE 6 - 4" PERFORATED HDPE DRAIN TILE W/ FILTER SOCK. CONNECT TO PROPOSED CATCH BASIN

MATCH INTO EXISTING BITUMINOUS PAVEMENT

GRADING LEGEND

---	= EXISTING MAJOR CONTOUR
- - -	= EXISTING MINOR CONTOUR
-100-	= EXISTING CONTOUR LABEL
---	= PROPOSED MAJOR CONTOUR
- - -	= PROPOSED MINOR CONTOUR
-100-	= PROPOSED CONTOUR LABEL
XXXX.XX	= EXISTING SPOT ELEVATION
XXXX.XX	= PROPOSED SPOT ELEVATION*

*SPOT ELEVATIONS ALONG CURB & GUTTER AND OTHER REVEALS ARE TO FLOWLINE, UNLESS OTHERWISE NOTED.

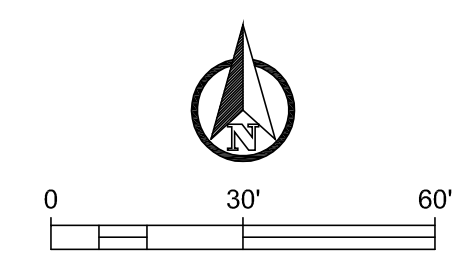

JLG ARCHITECTS
BOTTINEAU RIDGE II APARTMENTS
 MAPLE GROVE, MN

DATE
12/04/2017

PHASE
100% CDs

PROJECT
16098

SHEET
C301
 GRADING PLAN



322 1st Ave N, Suite #600
 Minneapolis, MN 55401
 phone 612.746.4260
 facsimile 612.746.4754
 www.jlgarchitects.com
 copyright © 2016

I HEREBY CERTIFY THAT THIS SURVEY, PLAN, OR REPORT WAS PREPARED BY ME OR UNDER MY DIRECT SUPERVISION AND THAT I AM A DULY LICENSED ENGINEER UNDER THE LAWS OF THE STATE OF MINNESOTA.

Thomas E. Anderson
 THOMAS E. ANDERSON
 44223 12.04.2017
 L.I.C. NO. DATE

REVISION SCHEDULE		
NO.	DESCRIPTION	DATE

GENERAL NOTES:

1. THE LOCATIONS AND ELEVATIONS OF THE EXISTING UTILITIES SHOWN HEREIN ARE APPROXIMATE. THEY HAVE BEEN PLOTTED FROM AVAILABLE SURVEYS AND/OR RECORDS. THE CONTRACTOR IS RESPONSIBLE TO ENSURE THAT ANY EXISTING UTILITIES (SHOWN OR NOT SHOWN) ARE NOT DAMAGED DURING CONSTRUCTION.
2. CONTRACTOR SHALL FIELD VERIFY LOCATION AND ELEVATIONS OF ALL EXISTING UNDERGROUND UTILITIES.
3. CONTRACTOR SHALL FIELD VERIFY ALL BUILDING DIMENSIONS PRIOR TO ANY CONSTRUCTION.
4. WATER SERVICE PIPE SHALL BE 4" (D.I.P.). BURY AT THE LOCATIONS IDENTIFIED ON THE PLAN.
5. ALL WATER PIPING SHALL BE BURIED A MINIMUM OF 8'.
6. MAINTAIN A MINIMUM OF 10' OF SEPARATION BETWEEN SANITARY SEWER LINES AND WATER LINES.
7. SANITARY SEWER SERVICE PIPE AND FITTINGS SHALL BE 8" SCH 40 PVC. SANITARY SEWER SERVICES SHALL INCLUDE 8" PVC WYE, 8" PVC 45° BEND, 8" PVC SERVICE PIPE AND PVC CLEANOUT WITHIN 5' OF THE BUILDING FOR BUILDING CONNECTION.
8. SANITARY SEWER SERVICES SHALL HAVE A MINIMUM OF 2.00% GRADE
9. CLEANOUT SPACING SHALL NOT EXCEED 90'.
10. BUILDING SEWERS OR DRAINAGE PIPING OF CLAY OR MATERIALS THAT ARE NOT APPROVED FOR USE WITHIN A BUILDING SHALL NOT BE RUN OR LAID IN THE SAME TRENCH AS THE WATER PIPES UNLESS THE FOLLOWING REQUIREMENTS ARE MET:
 - THE BOTTOM OF THE WATER PIPE, AT POINTS, SHALL BE NOT LESS THAN 12 INCHES ABOVE THE TOP OF THE SEWER OR DRAIN LINE.
 - THE WATER PIPE SHALL BE PLACED ON A SOLID SHELF EXCAVATED AT ONE SIDE OF THE COMMON TRENCH WITH A CLEAR HORIZONTAL DISTANCE OF NOT LESS THAN 12-INCHES FROM THE SEWER OR DRAIN LINE.
11. WATER PIPES CROSSING SEWER OR DRAINAGE PIPING CONSTRUCTED OF CLAY OR MATERIALS THAT ARE NOT APPROVED FOR USE WITHIN A BUILDING SHALL BE LAID NOT LESS THAN 12 INCHES ABOVE THE SEWER OR DRAIN PIPE.
12. ALL CONSTRUCTION AND MATERIALS SHALL BE IN ACCORDANCE WITH THE MINNESOTA STATE PLUMBING CODE.
13. ALL PIPING SHALL BE TESTED IN ACCORDANCE WITH THE MINNESOTA STATE PLUMBING CODE.
14. GOPHER STATE ONE CALL DAMAGE PREVENTION SYSTEM FOR BURIED UTILITIES. 1-800-252-1166

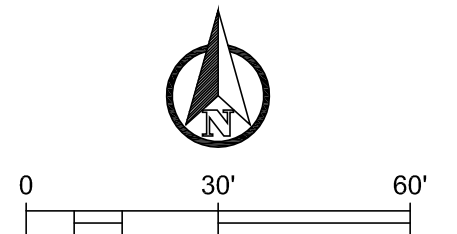
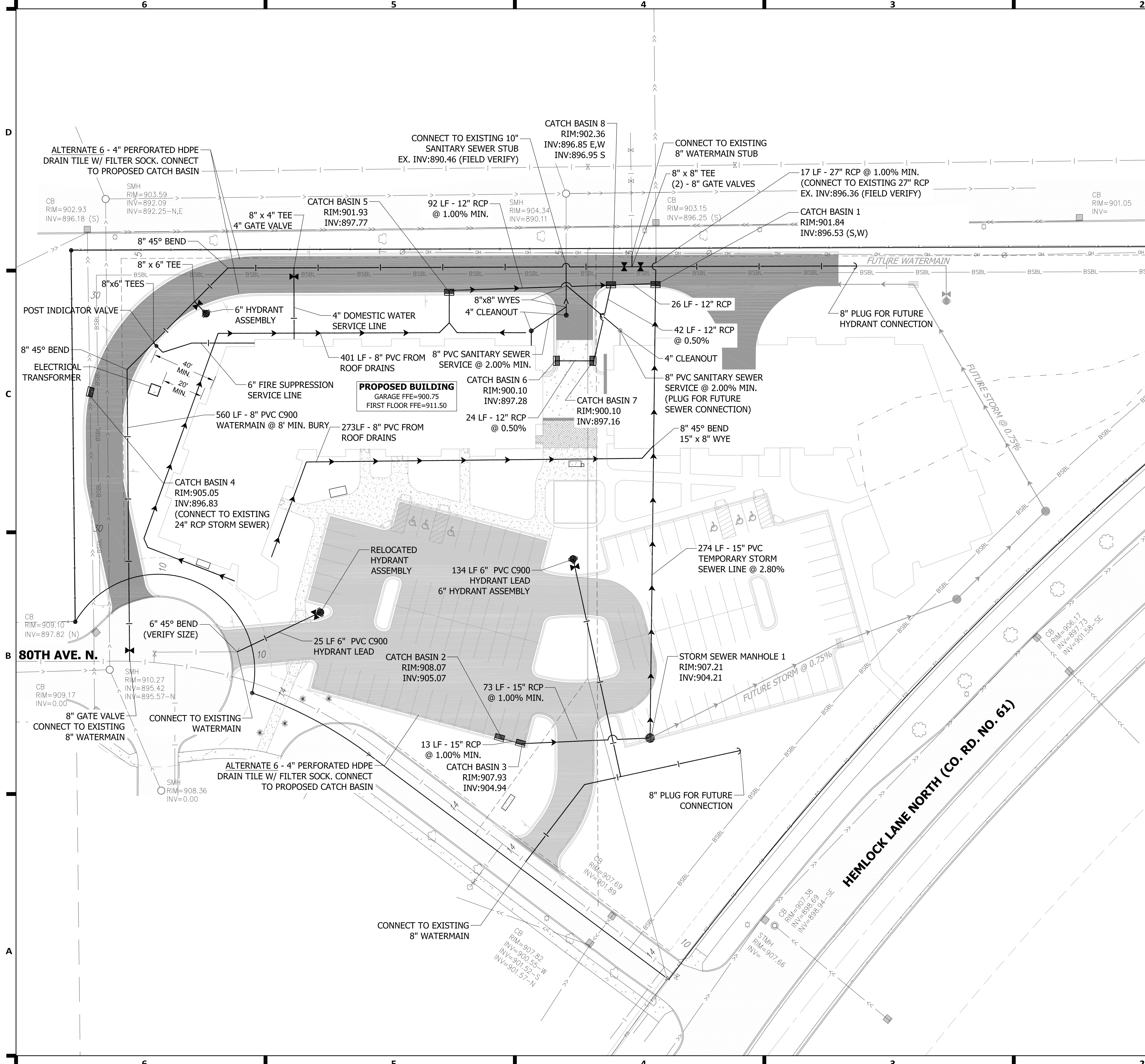

JLG ARCHITECTS
BOTTINEAU RIDGE II APARTMENTS
 MAPLE GROVE, MN

DATE
 12/04/2017

PHASE
 100% CDs

PROJECT
 16098

SHEET
C401
 UTILITY PLAN

6

5

4

3

2

1

D

C

B

A

NOTES:

1. ALL DISTURBED AREAS SHALL BE RESTORED AND SEEDED WITH SEED MIX 25-251 (HYDROSEED) OR SOD.
2. INLET PROTECTION SHALL BE PROVIDED ON ALL CATCH BASINS AND INLETS DOWN GRADIENT OF CONSTRUCTION ACTIVITY.
3. PROVIDE SILT FENCE PERIMETER CONTROL AROUND ENTIRE CONSTRUCTION ACTIVITY.
4. TEMPORARY ROCK ENTRANCES SHALL BE INSTALLED AND MAINTAINED THROUGHOUT THE DURATION OF CONSTRUCTION.
5. NO OFFSITE VEHICLE TRACKING IS PERMITTED. STREETS SHALL BE CLEANED AND SWEEPED WHENEVER TRACKING OF SEDIMENTS OCCURS AND BEFORE SITES ARE LEFT IDLE FOR WEEKENDS AND HOLIDAYS.
6. REFER TO SWPPP TEMPLATE AND THE CITY OF MAPLE GROVE EROSION CONTROL REQUIREMENTS FOR FURTHER EROSION CONTROL SEQUENCING.
7. INFILTRATION BASINS SHALL BE PROTECTED AT ALL TIMES THROUGHOUT THE DURATION OF CONSTRUCTION. NO HEAVY MACHINERY ALLOWED IN INFILTRATION BASIN TO PREVENT COMPACTION OF UNDERLYING SOILS. SMALL TRACK HOES AND SKIDSTEERS ARE RECOMMENDED.



322 1st Ave N, Suite #600
 Minneapolis, MN 55401
 phone 612.746.4260
 facsimile 612.746.4754
 www.jlgarchitects.com
 copyright © 2016

I HEREBY CERTIFY THAT THIS SURVEY, PLAN, OR REPORT WAS PREPARED BY ME OR UNDER MY DIRECT SUPERVISION AND THAT I AM A DULY LICENSED ENGINEER UNDER THE LAWS OF THE STATE OF MINNESOTA.

Thomas E. Anderson
 THOMAS E. ANDERSON
 44223 12.04.2017
 LIC. NO. DATE

REVISION SCHEDULE		
NO.	DESCRIPTION	DATE

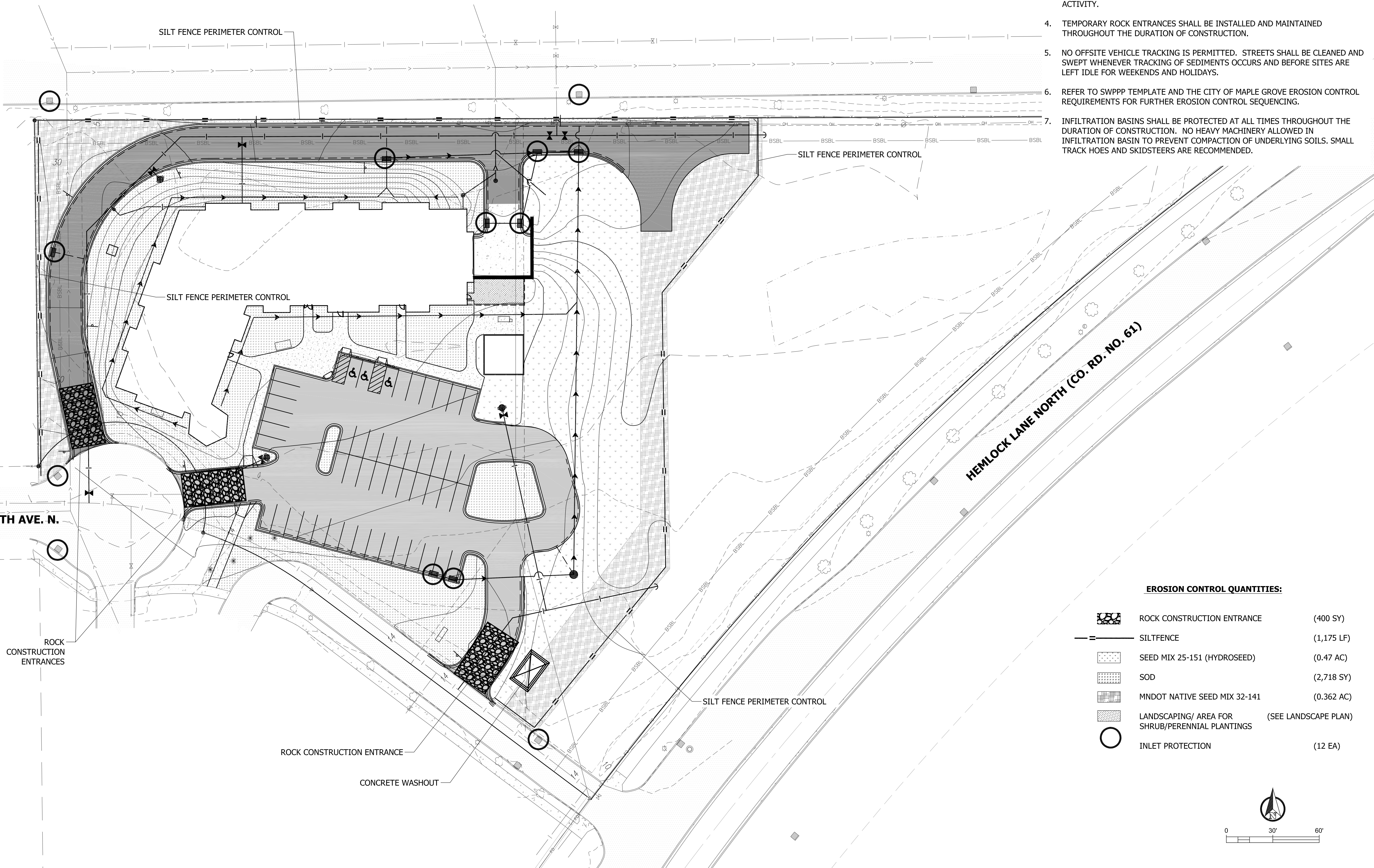

EROSION CONTROL QUANTITIES:

	ROCK CONSTRUCTION ENTRANCE	(400 SY)
	SILTFENCE	(1,175 LF)
	SEED MIX 25-251 (HYDROSEED)	(0.47 AC)
	SOD	(2,718 SY)
	MNDOT NATIVE SEED MIX 32-141	(0.362 AC)
	LANDSCAPING/ AREA FOR SHRUB/PERENNIAL PLANTINGS	(SEE LANDSCAPE PLAN)
	INLET PROTECTION	(12 EA)

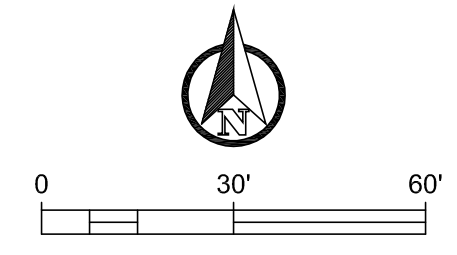

JLG ARCHITECTS
BOTTINEAU RIDGE II APARTMENTS
 MAPLE GROVE, MN

DATE
12/04/2017

PHASE
100% CDs

PROJECT
16098

SHEET
C501
 EROSION CONTROL PLAN

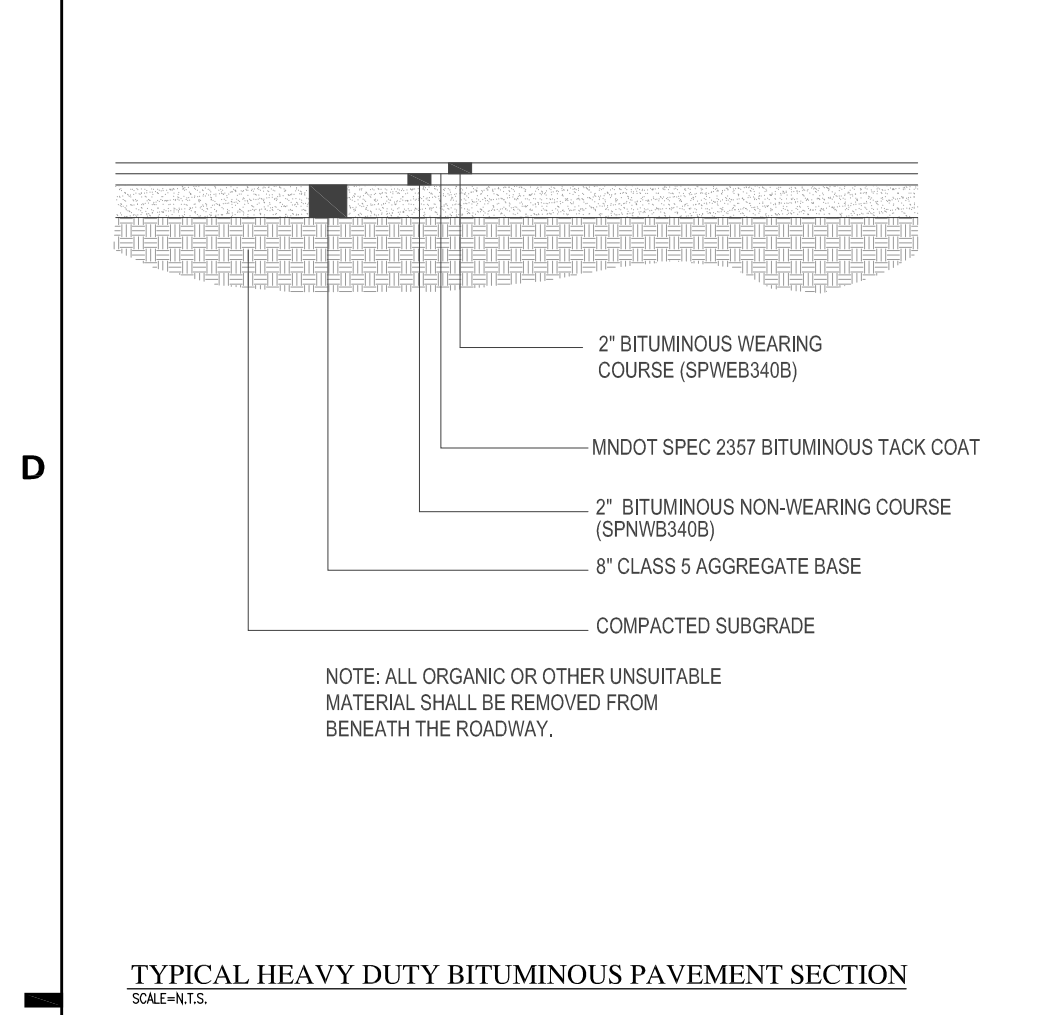

TYPICAL HEAVY DUTY BITUMINOUS PAVEMENT SECTION
SCALE: 1/4\"/>

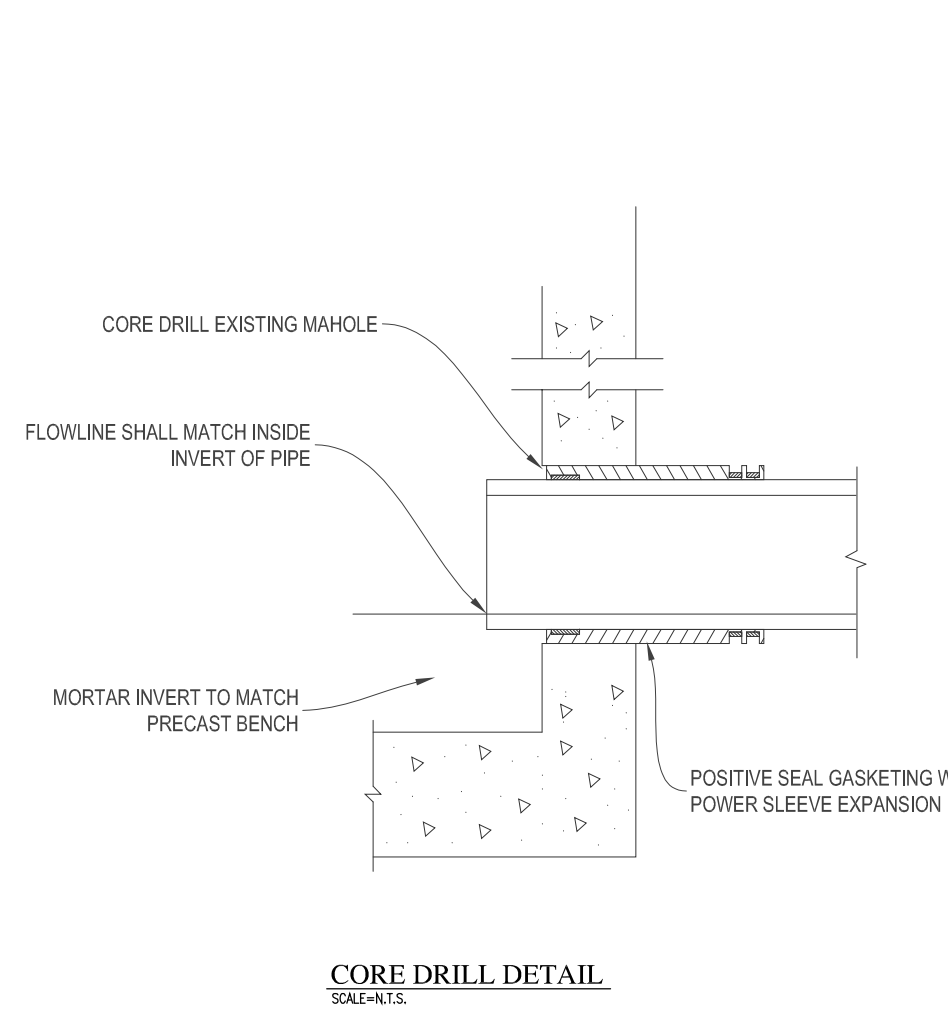

CORE DRILL DETAIL
SCALE: 1/4\"/>

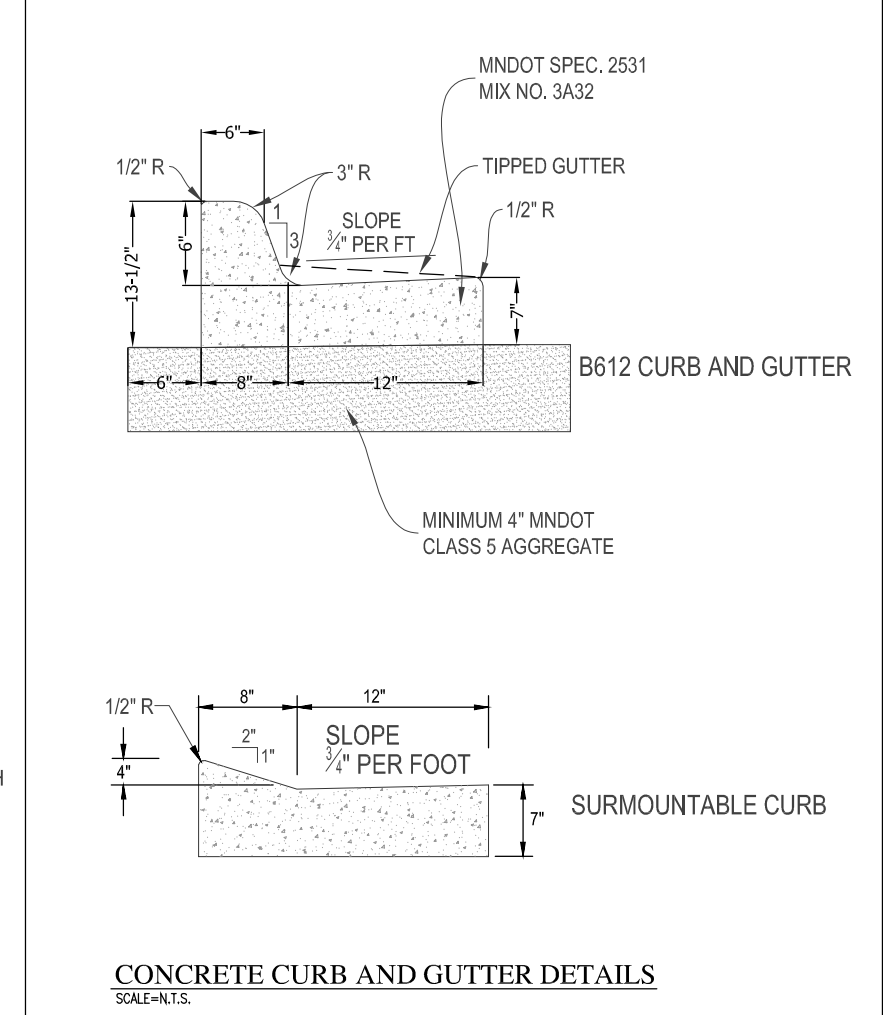

CONCRETE CURB AND GUTTER DETAILS
SCALE: 1/4\"/>

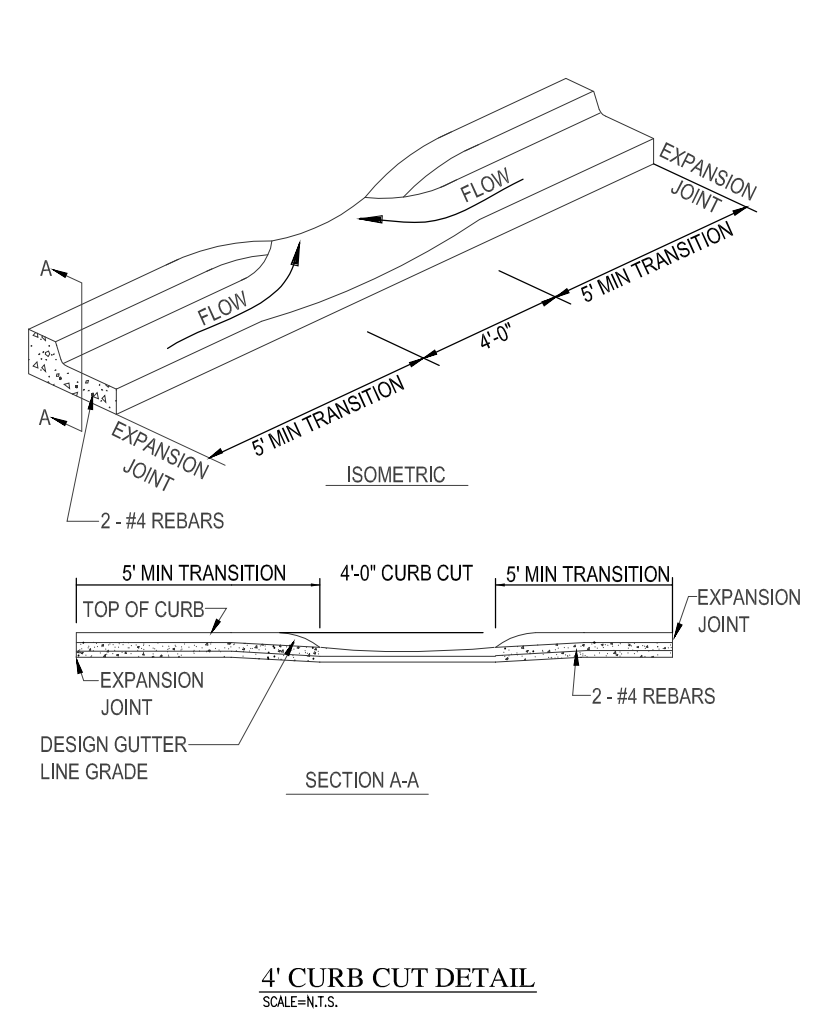

4\"/>

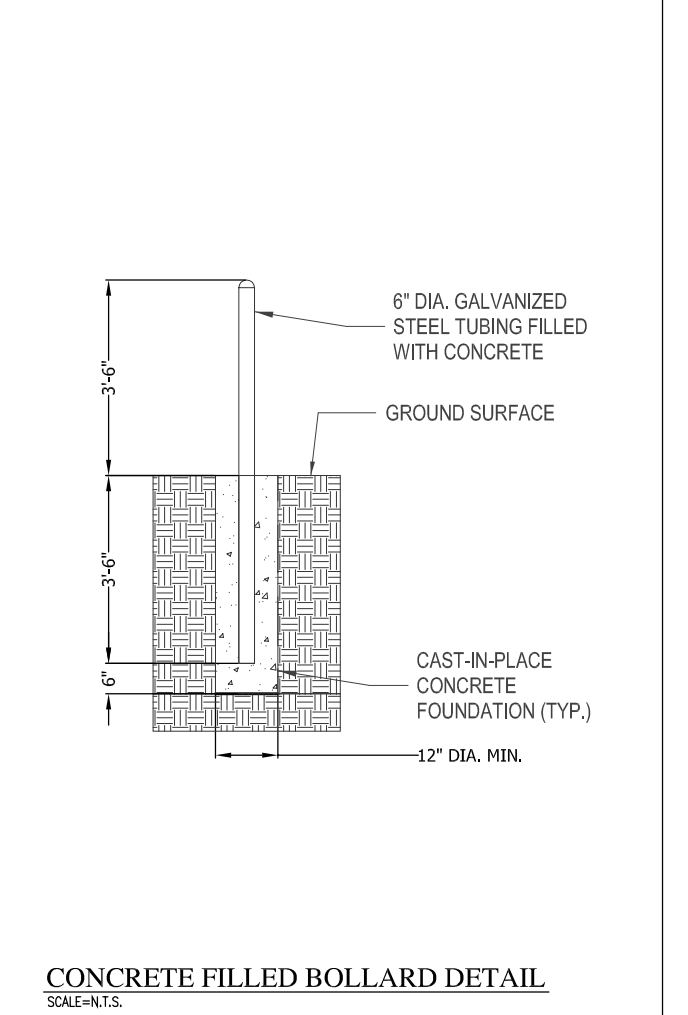

CONCRETE FILLED BOLLARD DETAIL
SCALE: 1/4\"/>

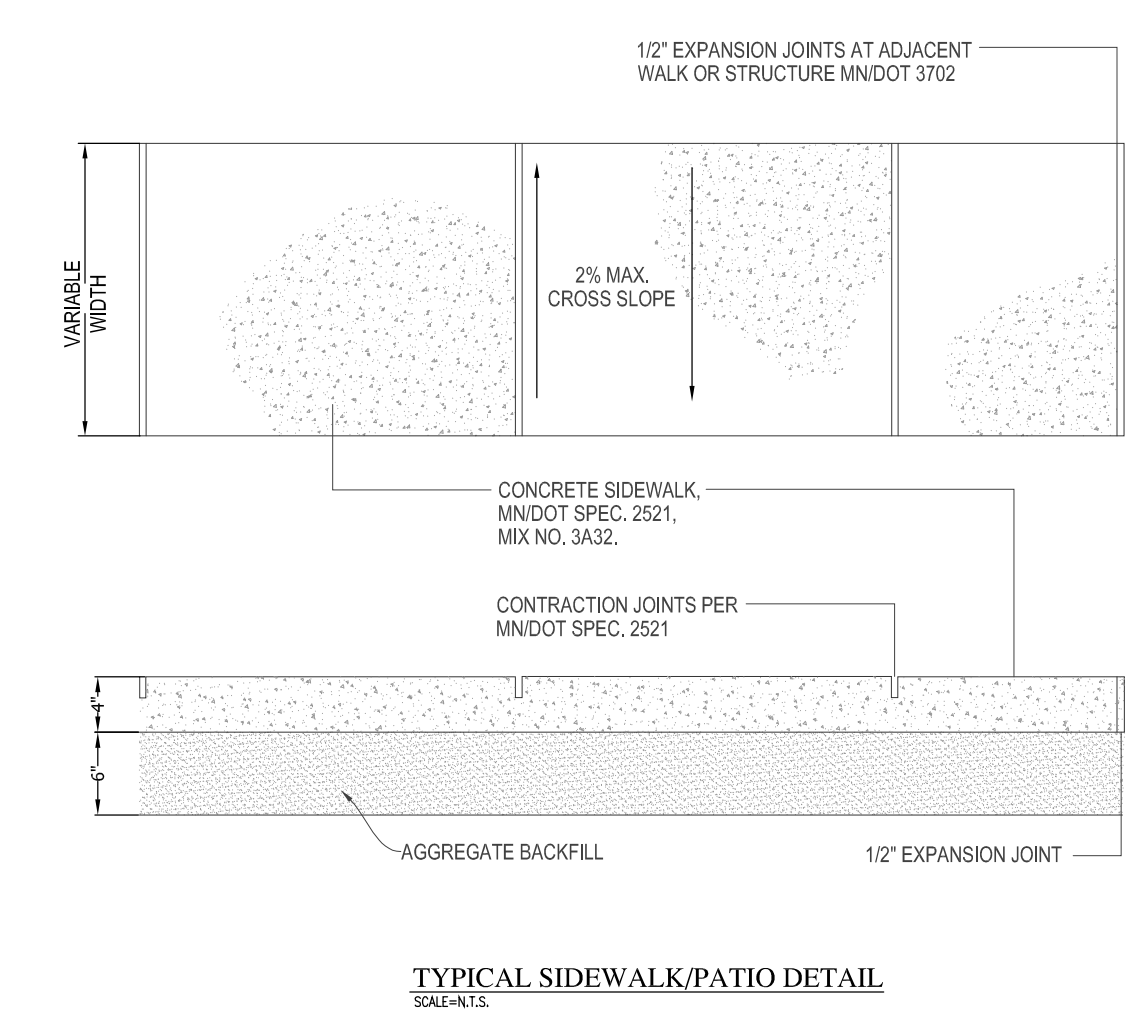

TYPICAL SIDEWALK/PATIO DETAIL
SCALE: 1/4\"/>

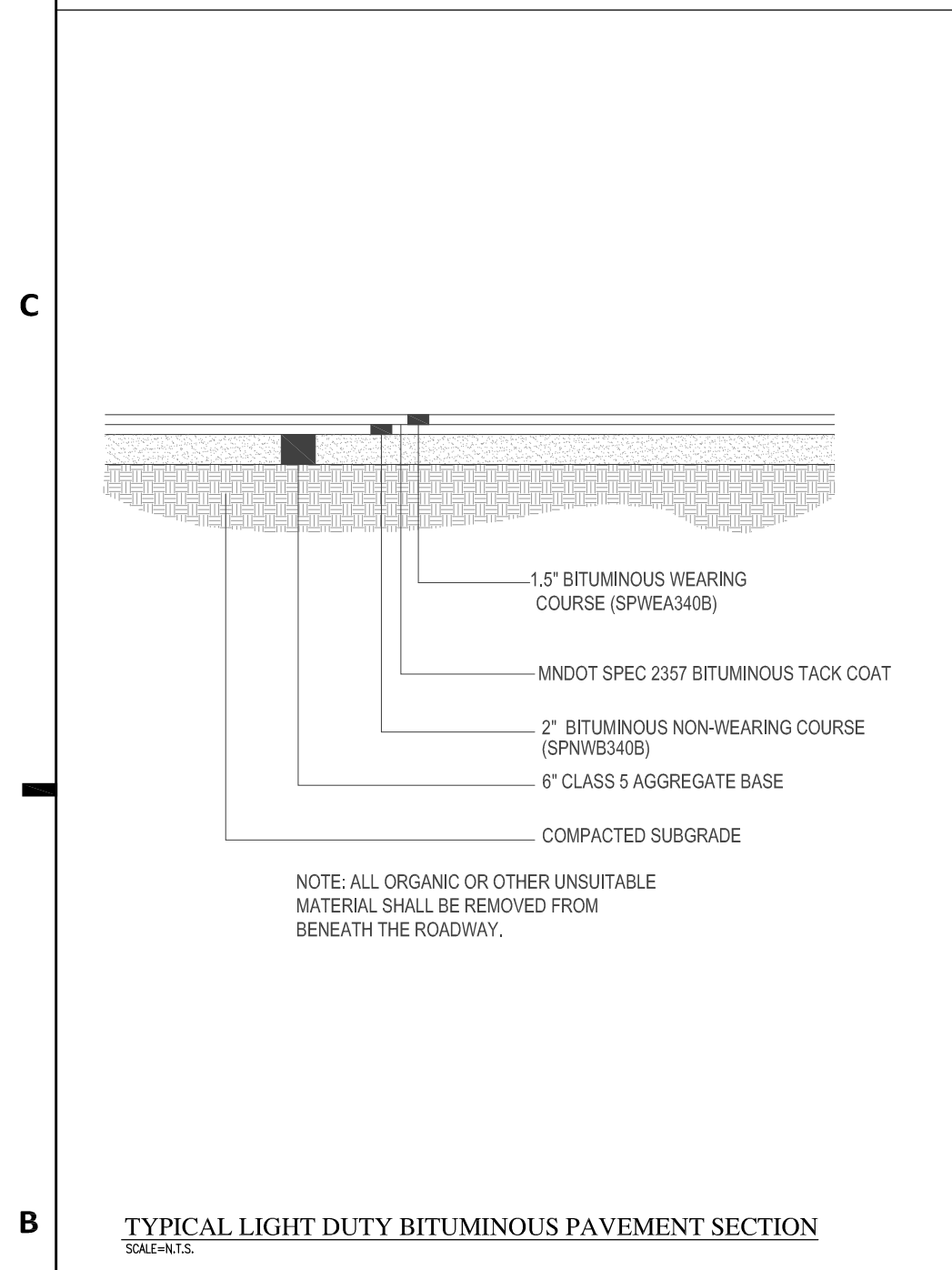

TYPICAL LIGHT DUTY BITUMINOUS PAVEMENT SECTION
SCALE: 1/4\"/>

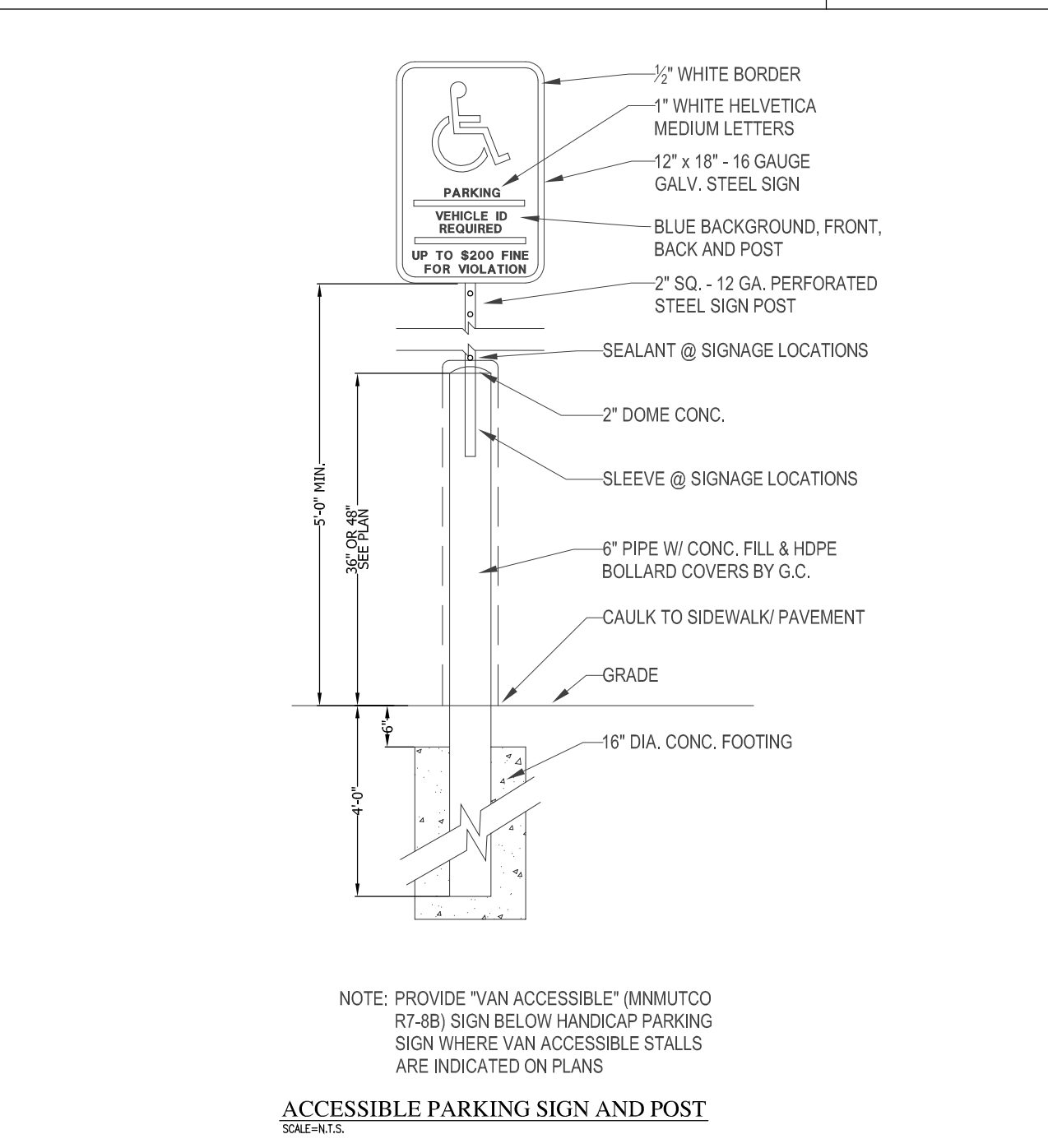

ACCESSIBLE PARKING SIGN AND POST
SCALE: 1/4\"/>

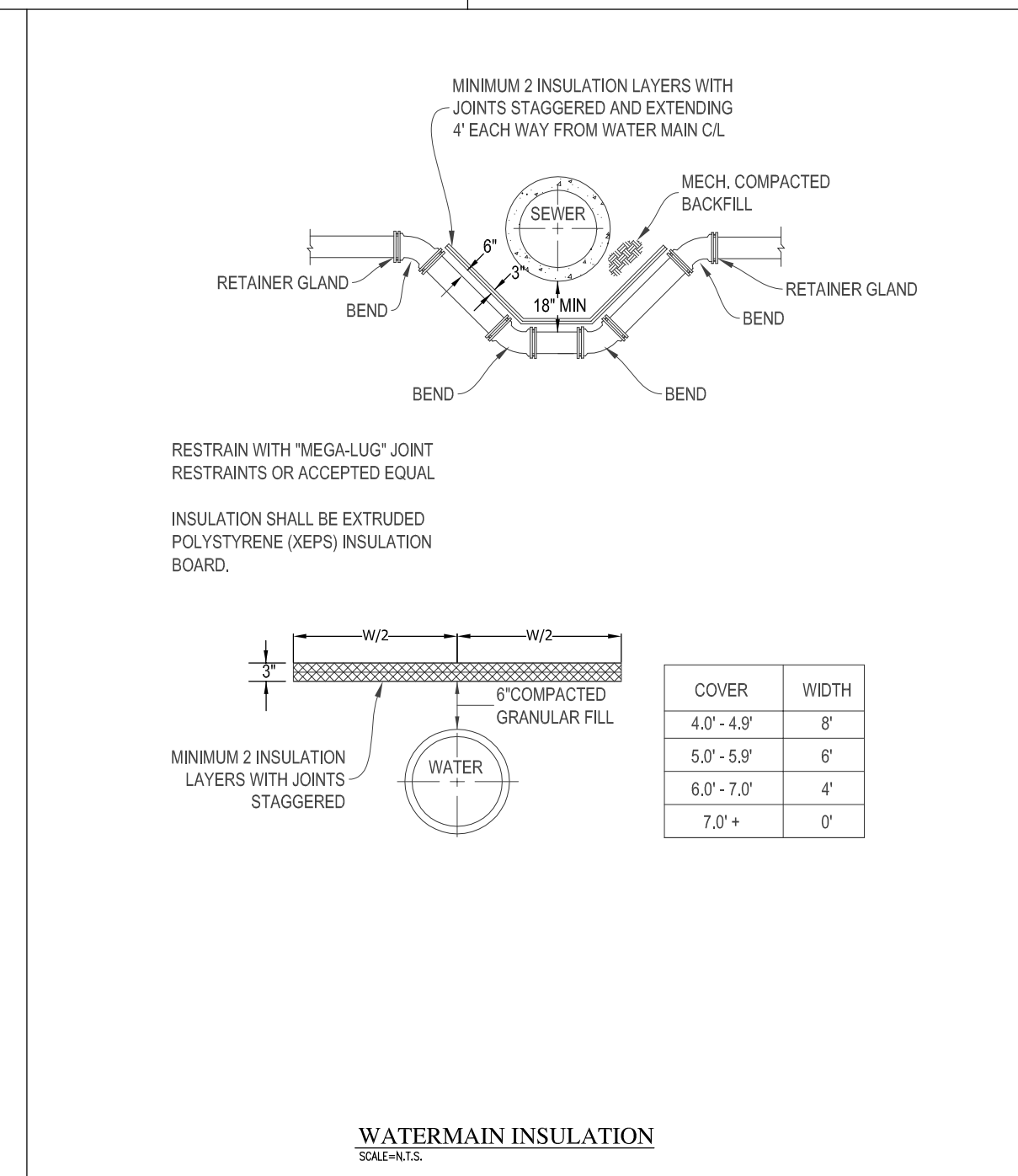

WATERMAIN INSULATION
SCALE: 1/4\"/>

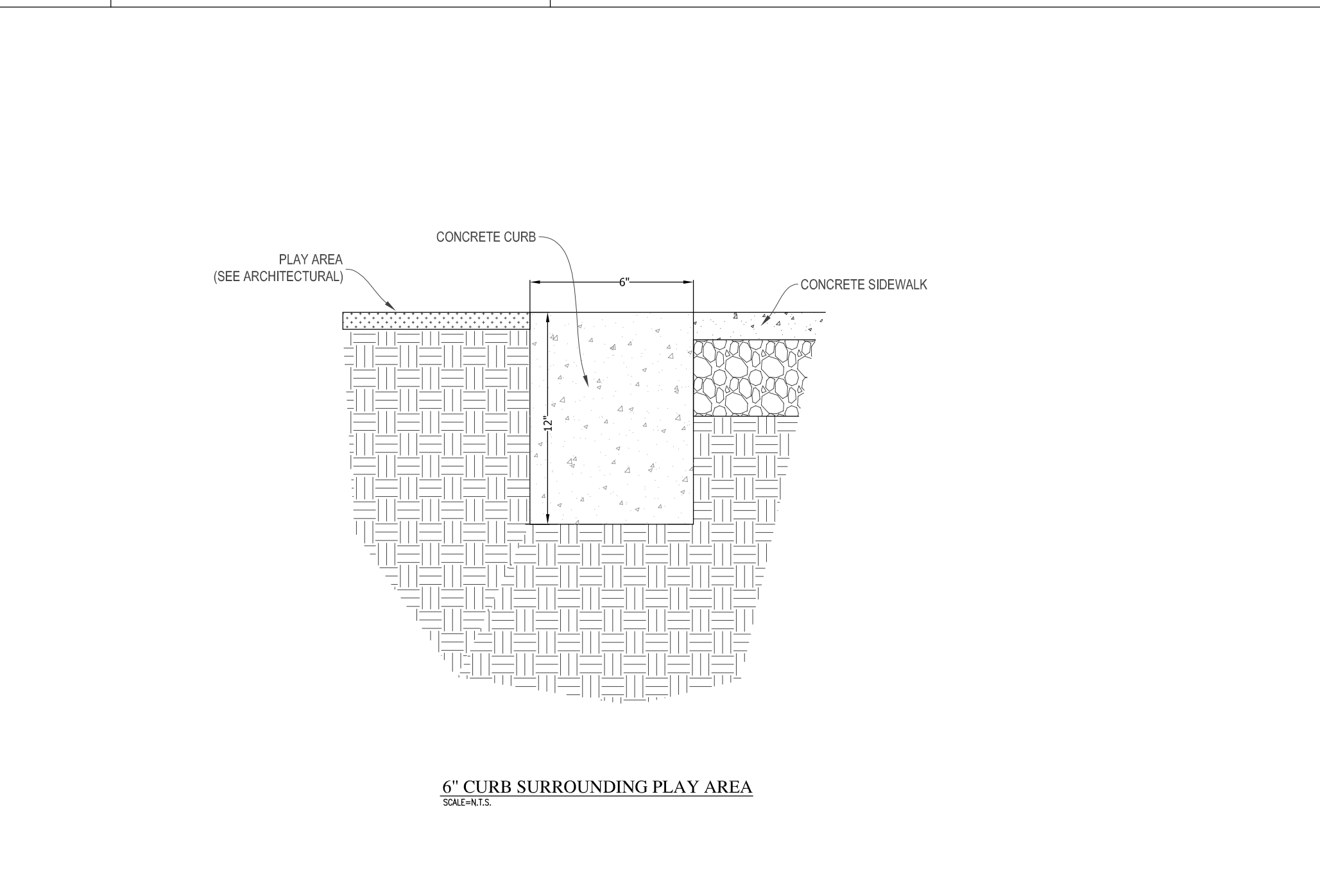

6\"/>

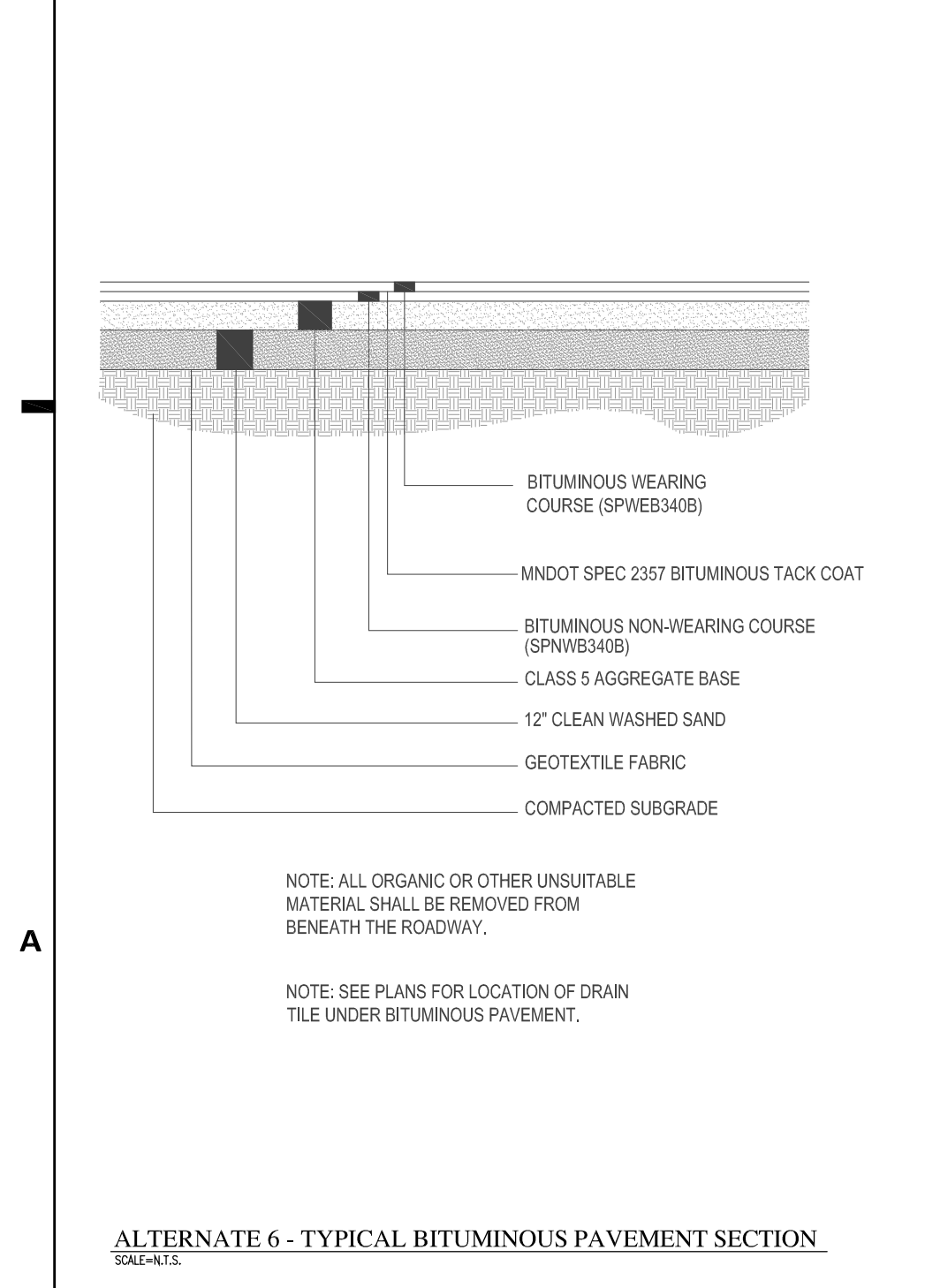

ALTERNATE 6 - TYPICAL BITUMINOUS PAVEMENT SECTION
SCALE: 1/4\"/>

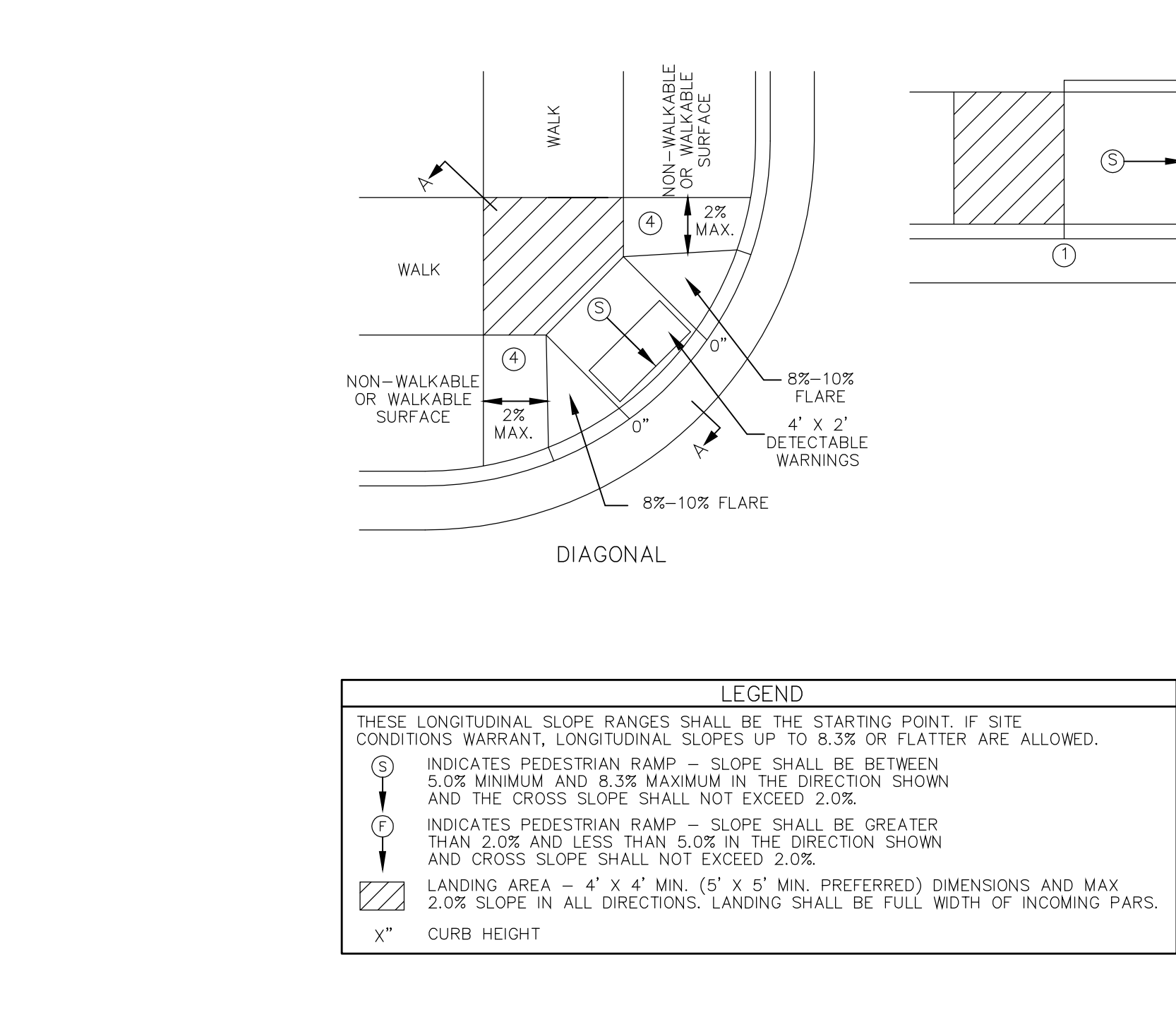

LEGEND

THESE LONGITUDINAL SLOPE RANGES SHALL BE THE STARTING POINT. IF SITE CONDITIONS WARRANT, LONGITUDINAL SLOPES UP TO 8.3% OR FLATTER ARE ALLOWED.

⑤ INDICATES PEDESTRIAN RAMP - SLOPE SHALL BE BETWEEN 5.0% MINIMUM AND 8.3% MAXIMUM IN THE DIRECTION SHOWN AND THE CROSS SLOPE SHALL NOT EXCEED 2.0%.

⑥ INDICATES PEDESTRIAN RAMP - SLOPE SHALL BE GREATER THAN 2.0% AND LESS THAN 5.0% IN THE DIRECTION SHOWN AND CROSS SLOPE SHALL NOT EXCEED 2.0%.

▨ LANDING AREA - 4' x 4' MIN. (5' x 5' MIN. PREFERRED) DIMENSIONS AND MAX 2.0% SLOPE IN ALL DIRECTIONS. LANDING SHALL BE FULL WIDTH OF INCOMING PARS.

X" CURB HEIGHT

PEDESTRIAN CURB RAMP STANDARD PLATE
SCALE: 1/4\"/>

NOTES:

LANDINGS SHALL BE LOCATED ANYWHERE THE PEDESTRIAN ACCESS ROUTE (PAR) CHANGES DIRECTION, AT THE TOP OF RAMPS THAT HAVE RUNNING SLOPES GREATER THAN 5.0%, AND IF THE APPROACHING WALK IS INVERSE GRADE GREATER THAN 2%.

INITIAL CURB RAMP LANDINGS SHALL BE CONSTRUCTED WITHIN 15' FROM THE BACK OF CURB, WITH 6' FROM THE BACK OF CURB BEING THE PREFERRED DISTANCE, ONLY APPLICABLE WHEN THE INITIAL RAMP RUNNING SLOPE IS OVER 5.0%.

SECONDARY CURB RAMP LANDINGS ARE REQUIRED FOR EVERY 30" OF VERTICAL RISE WHEN THE LONGITUDINAL RUNNING SLOPE IS GREATER THAN 5.0%.

CONTRACTION JOINTS SHALL BE CONSTRUCTED ALONG ALL GRADE BREAKS WITHIN THE PAR. 1/4" DEEP VISUAL JOINTS SHALL BE USED AT THE TOPS OF CONCRETE FLARES ADJACENT TO WALKABLE SURFACES. ALL GRADE BREAKS WITHIN THE PAR SHALL BE PERPENDICULAR TO THE PATH OF TRAVEL. THUS BOTH SIDES OF A SLOPED WALKING SURFACE MUST BE EQUAL LENGTH.

TO ENSURE INITIAL RAMPS AND INITIAL LANDINGS ARE PROPERLY CONSTRUCTED, LANDINGS SHALL BE CAST SEPARATELY. FOLLOW SIDEWALK REINFORCEMENT DETAILS ON SHEET 6 AND THE ADA SPECIAL PROVISIONS - PROSECUTION OF WORK (ADA).

TOP OF CURB SHALL MATCH PROPOSED ADJACENT WALK GRADE.

WHEN THE BOULEVARD IS 4' WIDE OR LESS, THE TOP OF CURB TAPER SHALL MATCH THE RAMP SLOPES TO REDUCE NEGATIVE BOULEVARD SLOPES FROM THE TOP BACK OF CURB TO THE PAR.

ALL RAMP TYPES SHOULD HAVE A MINIMUM 3' LONG RAMP LENGTH.

4' MINIMUM WIDTH OF DETECTABLE WARNING IS REQUIRED FOR ALL RAMPS. DETECTABLE WARNINGS SHALL CONTINUOUSLY EXTEND FOR A MIN. OF 24" IN THE PATH OF TRAVEL. DETECTABLE WARNING TO COVER ENTIRE WIDTH OF SHARED-USE PATHS AND THE ENTIRE PAR WIDTH OF THE WALK. DETECTABLE WARNING SHOULD BE 6" LESS THAN THE PAR/TRAIL WIDTH. ARC LENGTH OF RADIAL DETECTABLE WARNINGS SHOULD NOT BE GREATER THAN 20 FEET.

RECTANGULAR DETECTABLE WARNINGS SHALL BE SETBACK 3" FROM THE BACK OF CURB. RADIAL DETECTABLE WARNINGS SHALL BE SETBACK 3" MINIMUM TO 6" MAXIMUM FROM THE BACK OF CURB.

① MATCH FULL HEIGHT CURB.

② DETECTABLE WARNINGS MAY BE PART OF THE 4' x 4' MIN. LANDING AREA IF IT IS NOT FEASIBLE TO CONSTRUCT THE LANDING OUTSIDE OF THE DETECTABLE WARNING AREA.

③ WHEN ADJACENT TO GRASS, GRADING SHALL ALWAYS BE USED WHEN FEASIBLE. V CURB, IF USED, SHALL BE PLACED OUTSIDE THE SIDEWALK LIMITS WHEN RIGHT OF WAY ALLOWS. WHEN ADJACENT TO PARKING LOTS, CONCRETE OR BITUMINOUS TAPERS SHOULD BE USED OVER V CURB TO REDUCE TRIPPING HAZARDS AND FACILITATE SNOW & ICE REMOVAL.

④ PAVE FULL WALK WIDTH.



322 1st Ave N, Suite #600
Minneapolis, MN 55401
phone 612.746.4260
facsimile 612.746.4754
www.jlgarchitects.com
copyright © 2016

I HEREBY CERTIFY THAT THIS SURVEY, PLAN, OR REPORT WAS PREPARED BY ME OR UNDER MY DIRECT SUPERVISION AND THAT I AM A DULY LICENSED ENGINEER UNDER THE LAWS OF THE STATE OF MINNESOTA.

[Signature]
E. ANDERSON
LIC. NO. 44223
DATE 12.04.2017

REVISION SCHEDULE

NO.	DESCRIPTION	DATE

JLG ARCHITECTS
BOTTINEAU RIDGE II APARTMENTS
 MAPLE GROVE, MN

DATE
12/04/2017

PHASE
100% CDs

PROJECT
16098

SHEET
C601
CIVIL DETAILS

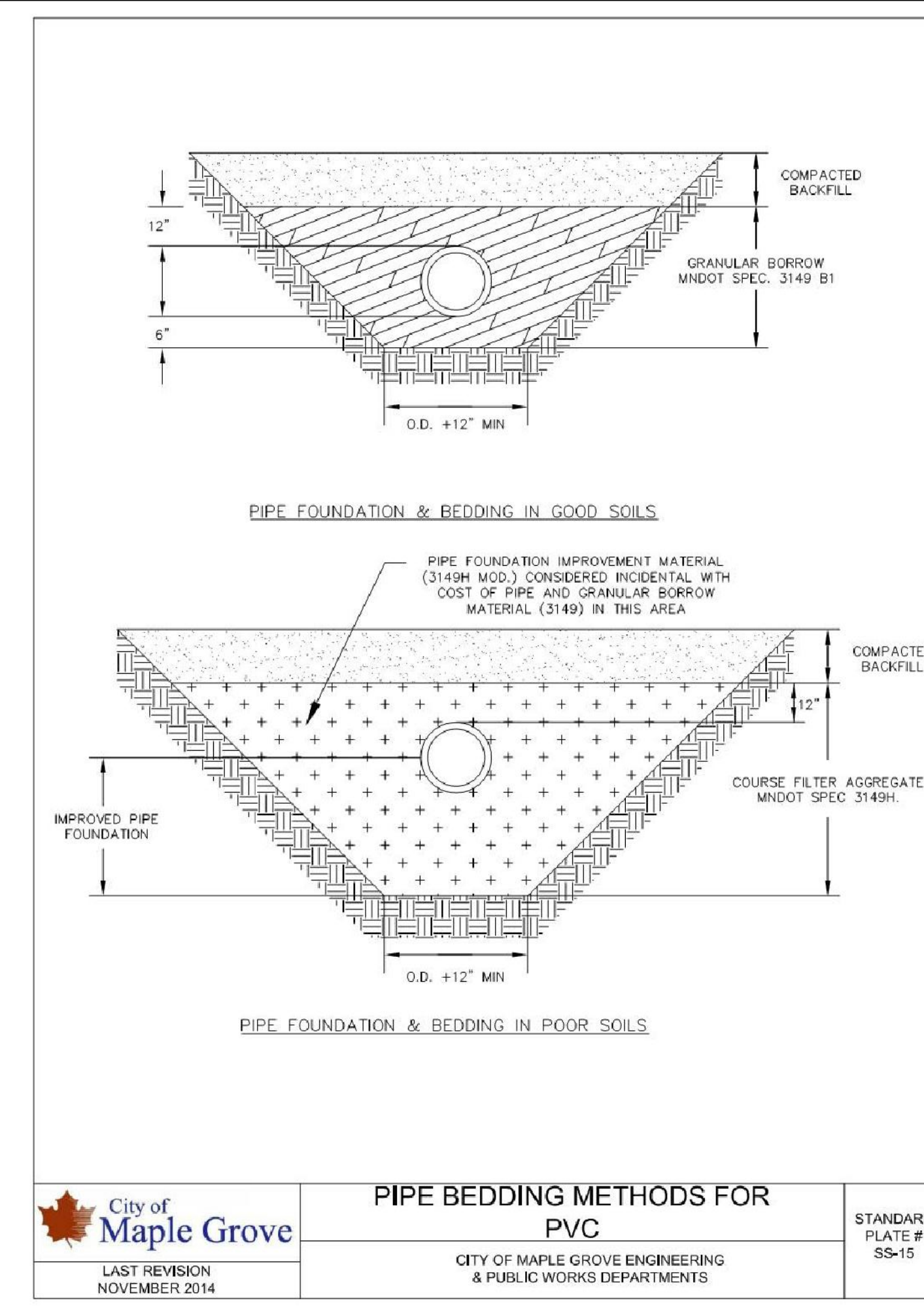
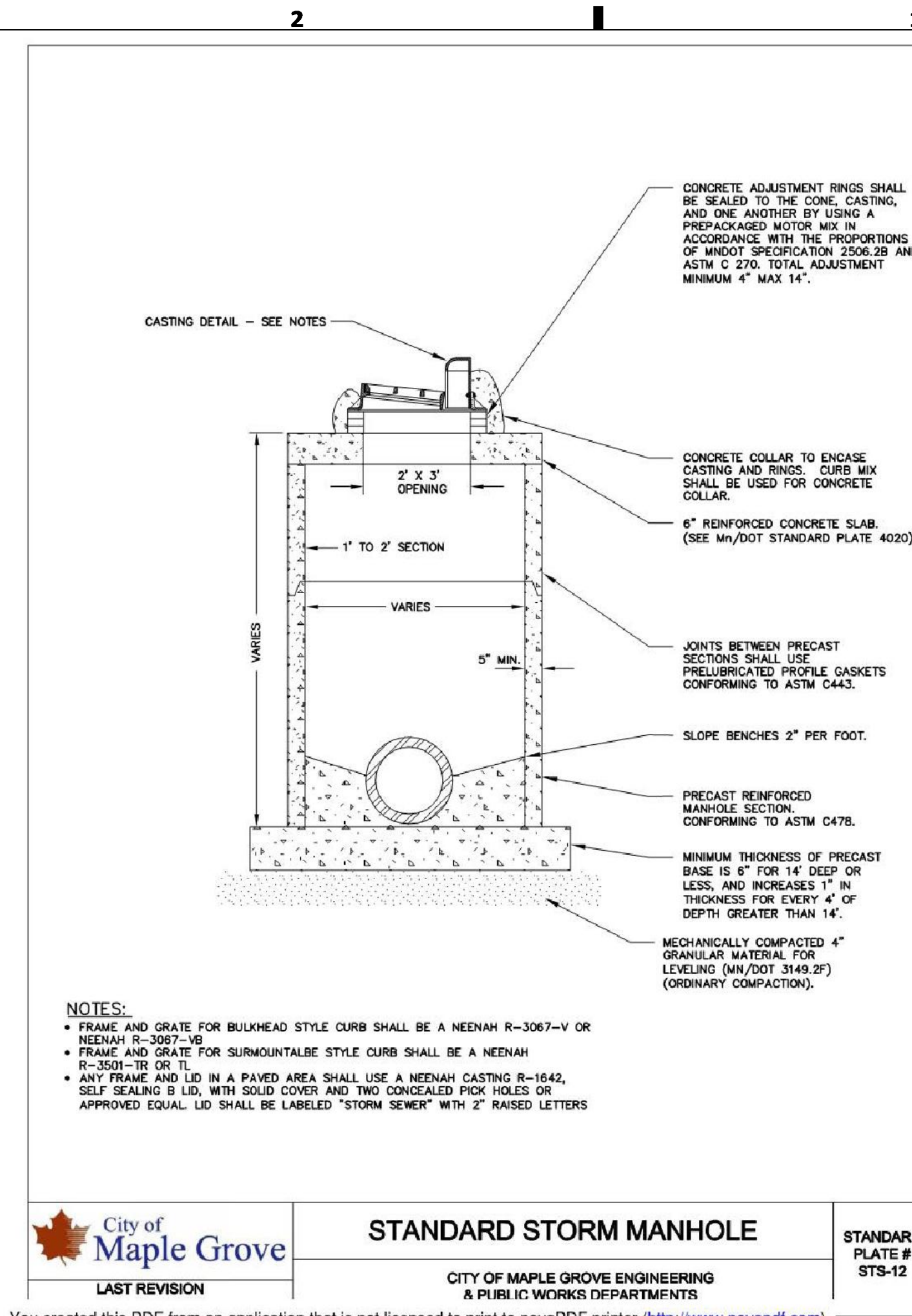
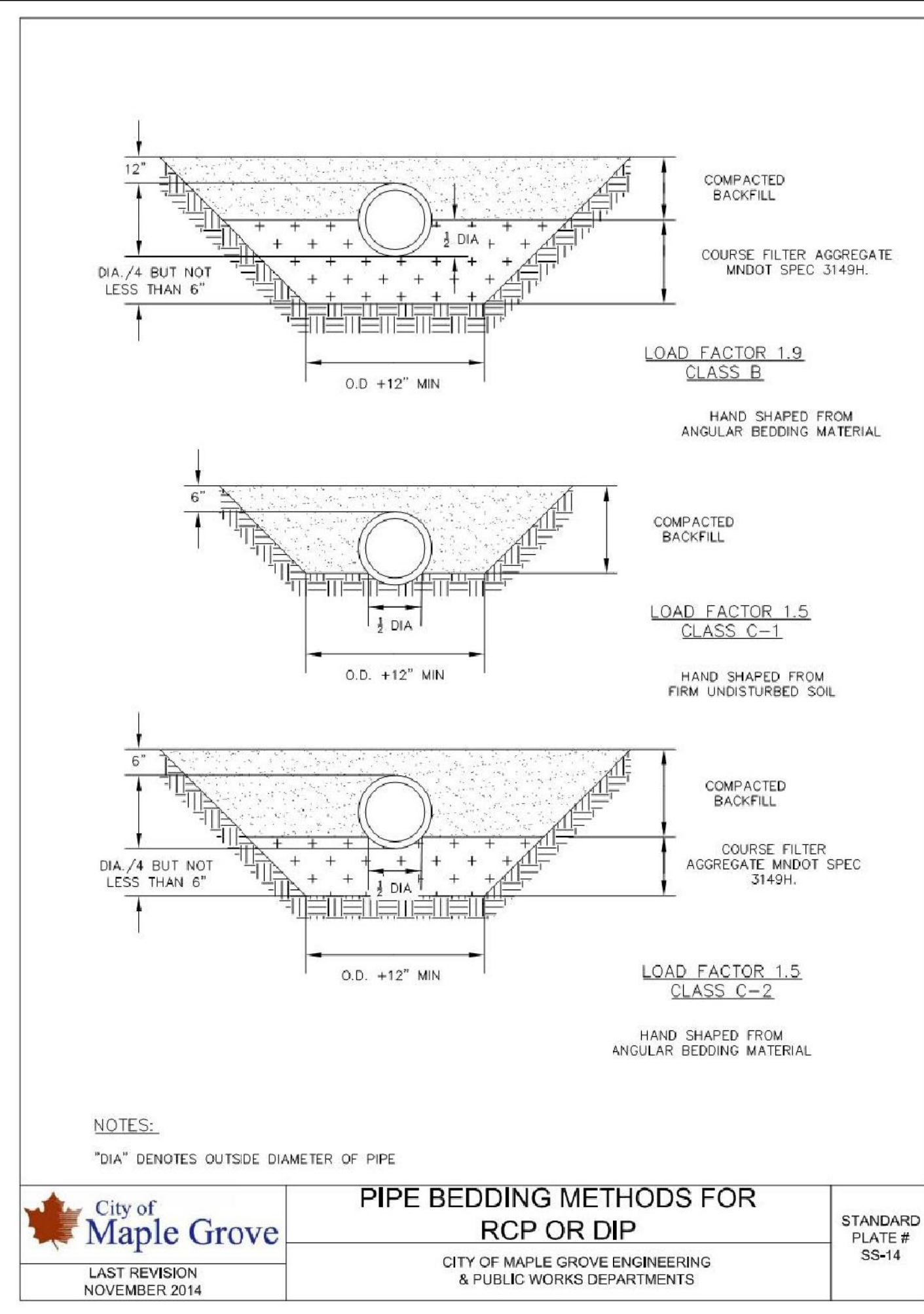
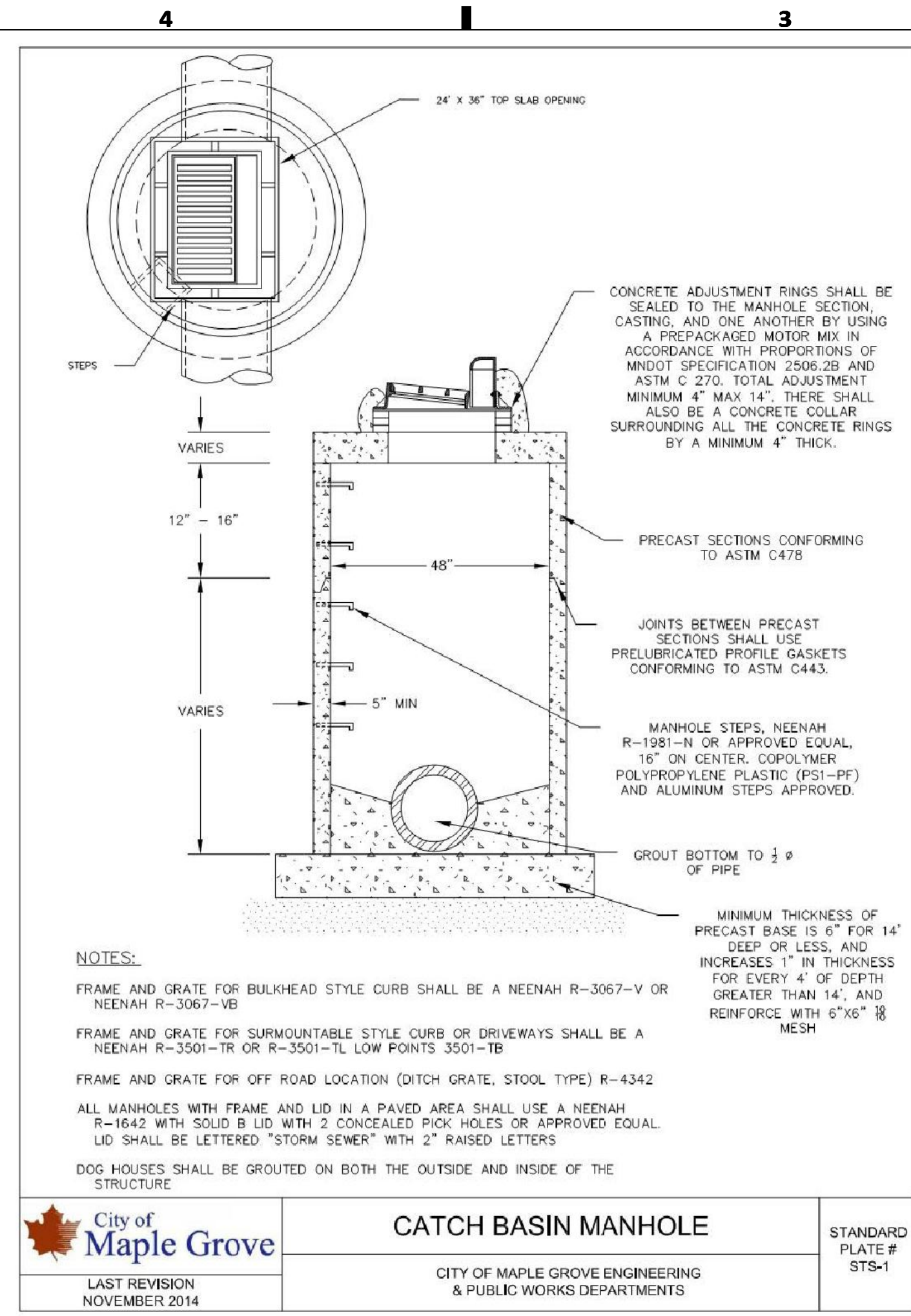
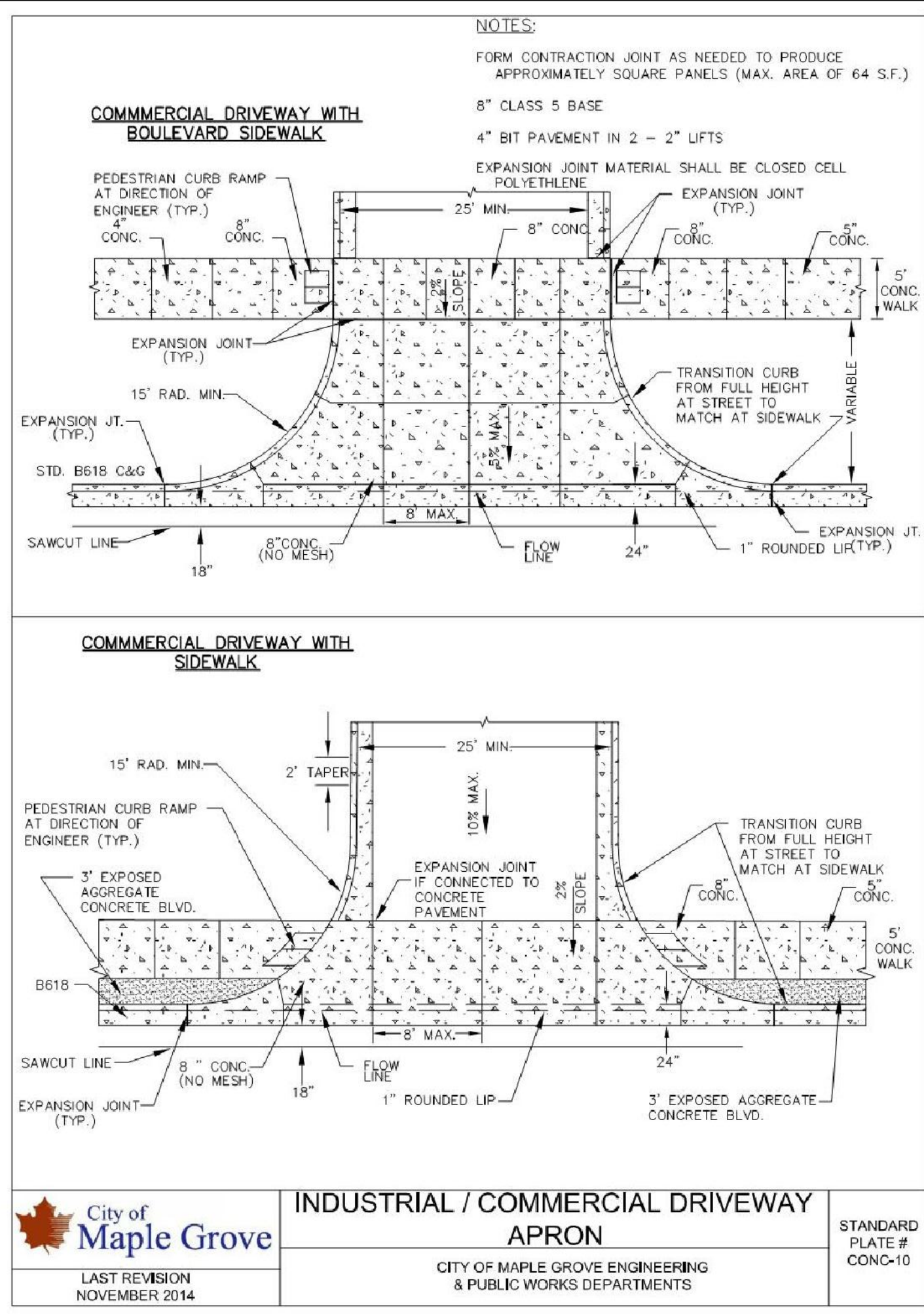
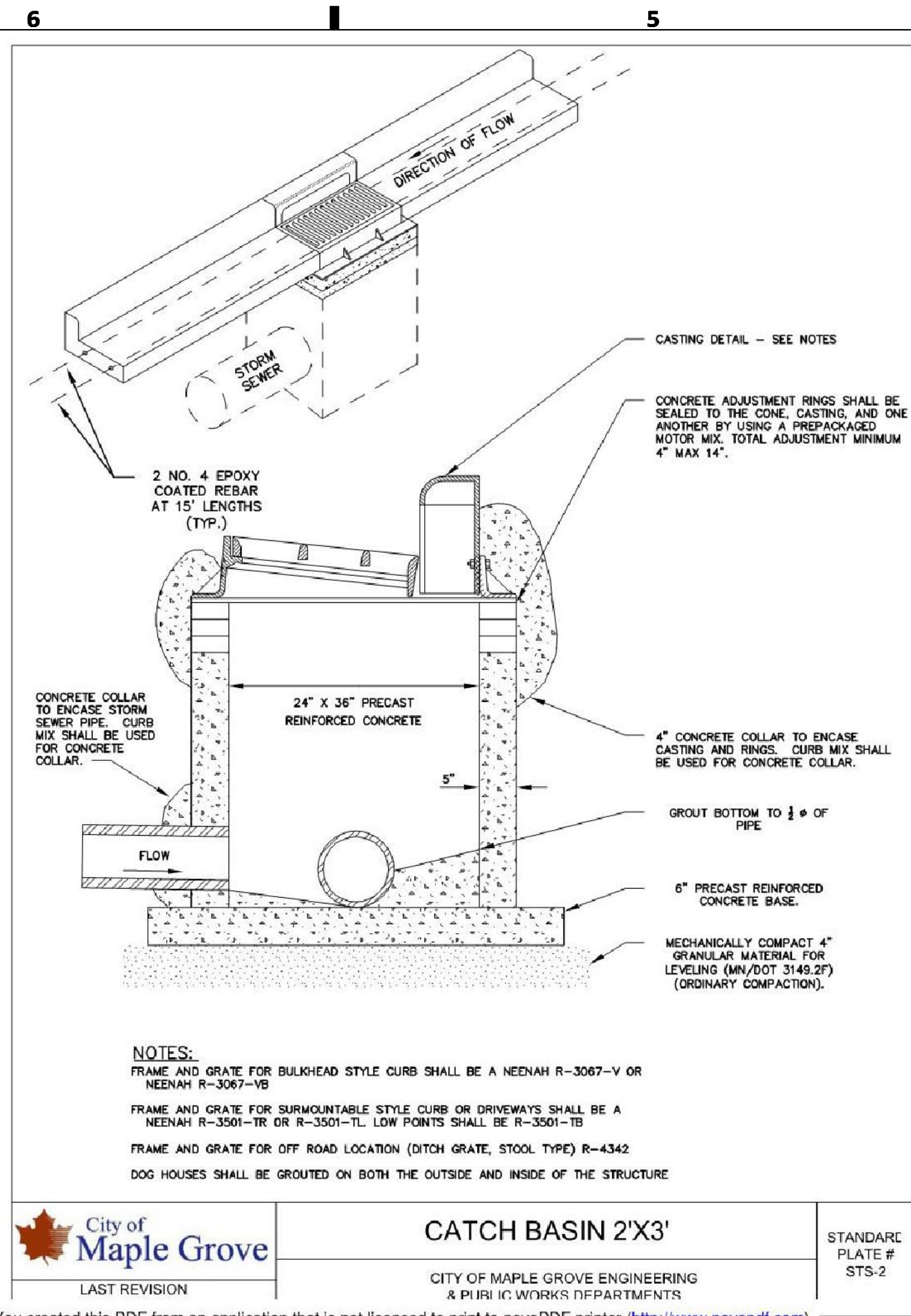

322 1st Ave N, Suite #600
 Minneapolis, MN 55401
 phone 612.746.4260
 facsimile 612.746.4754
 www.jlgarchitects.com
 copyright © 2016

I HEREBY CERTIFY THAT THIS SURVEY, PLAN, OR REPORT WAS PREPARED BY ME OR UNDER MY DIRECT SUPERVISION AND THAT I AM A DULY LICENSED ENGINEER UNDER THE LAWS OF THE STATE OF MINNESOTA.

[Signature]
 E. ANDERSON
 44223 12/04/2017
 LIC. NO. DATE

REVISION SCHEDULE		
NO.	DESCRIPTION	DATE

JLG ARCHITECTS
BOTTINEAU RIDGE II APARTMENTS
 MAPLE GROVE, MN

DATE
 12/04/2017

PHASE
 100% CDs

PROJECT
 16098

SHEET
C602
 CIVIL DETAILS

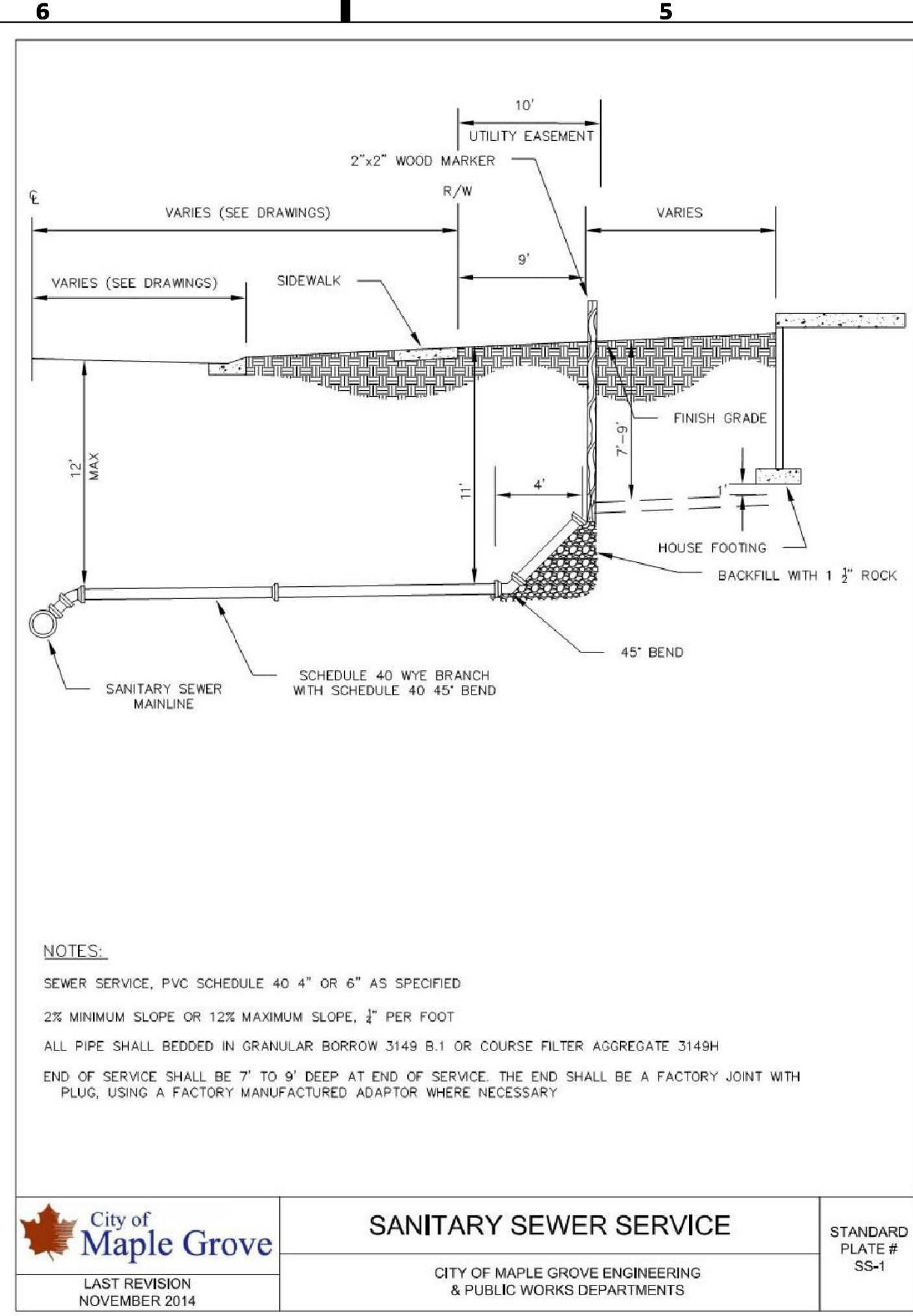

City of Maple Grove
LAST REVISION NOVEMBER 2014

SANITARY SEWER SERVICE
CITY OF MAPLE GROVE ENGINEERING & PUBLIC WORKS DEPARTMENTS

STANDARD PLATE # SS-1

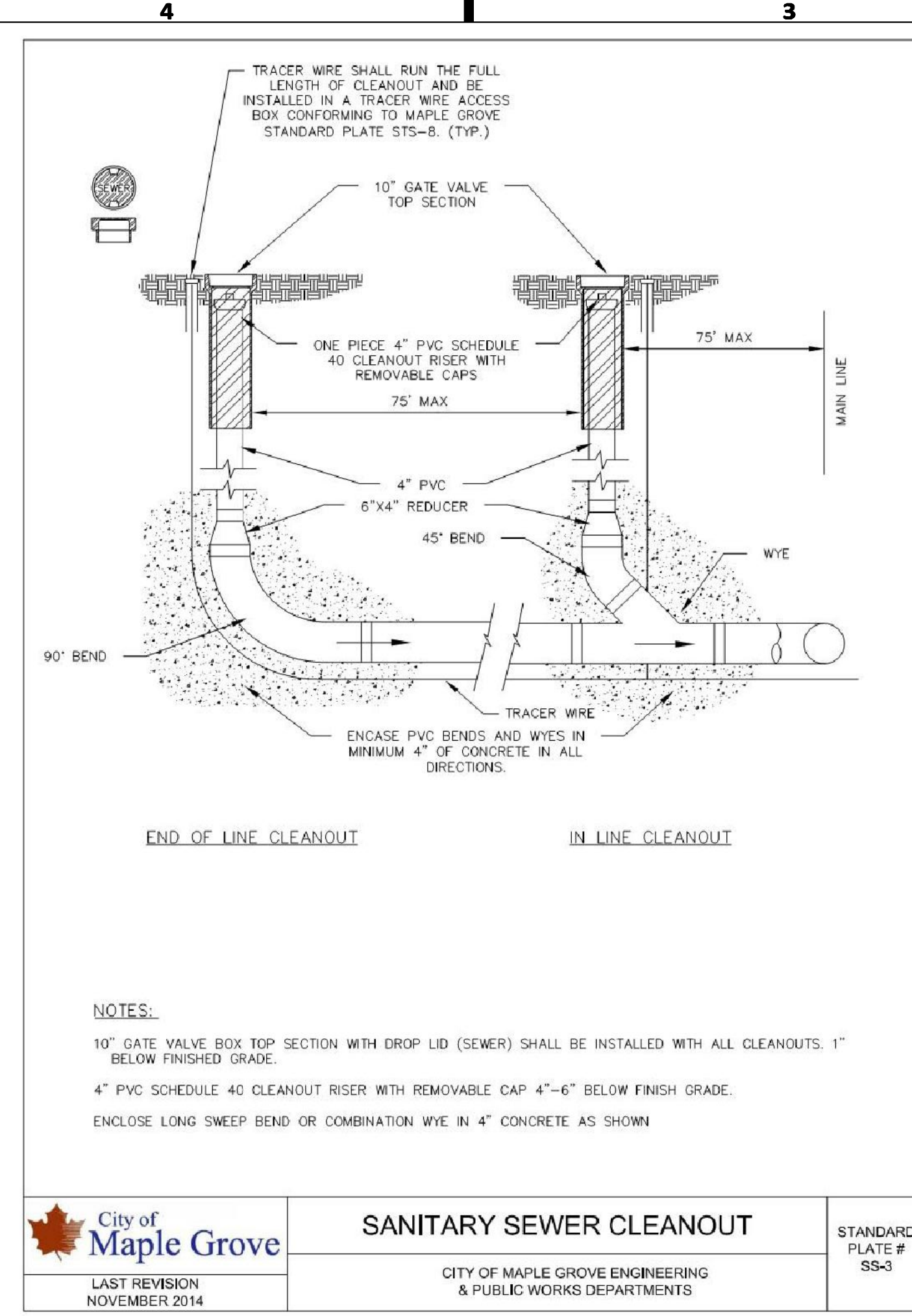

City of Maple Grove
LAST REVISION NOVEMBER 2014

SANITARY SEWER CLEANOUT
CITY OF MAPLE GROVE ENGINEERING & PUBLIC WORKS DEPARTMENTS

STANDARD PLATE # SS-3

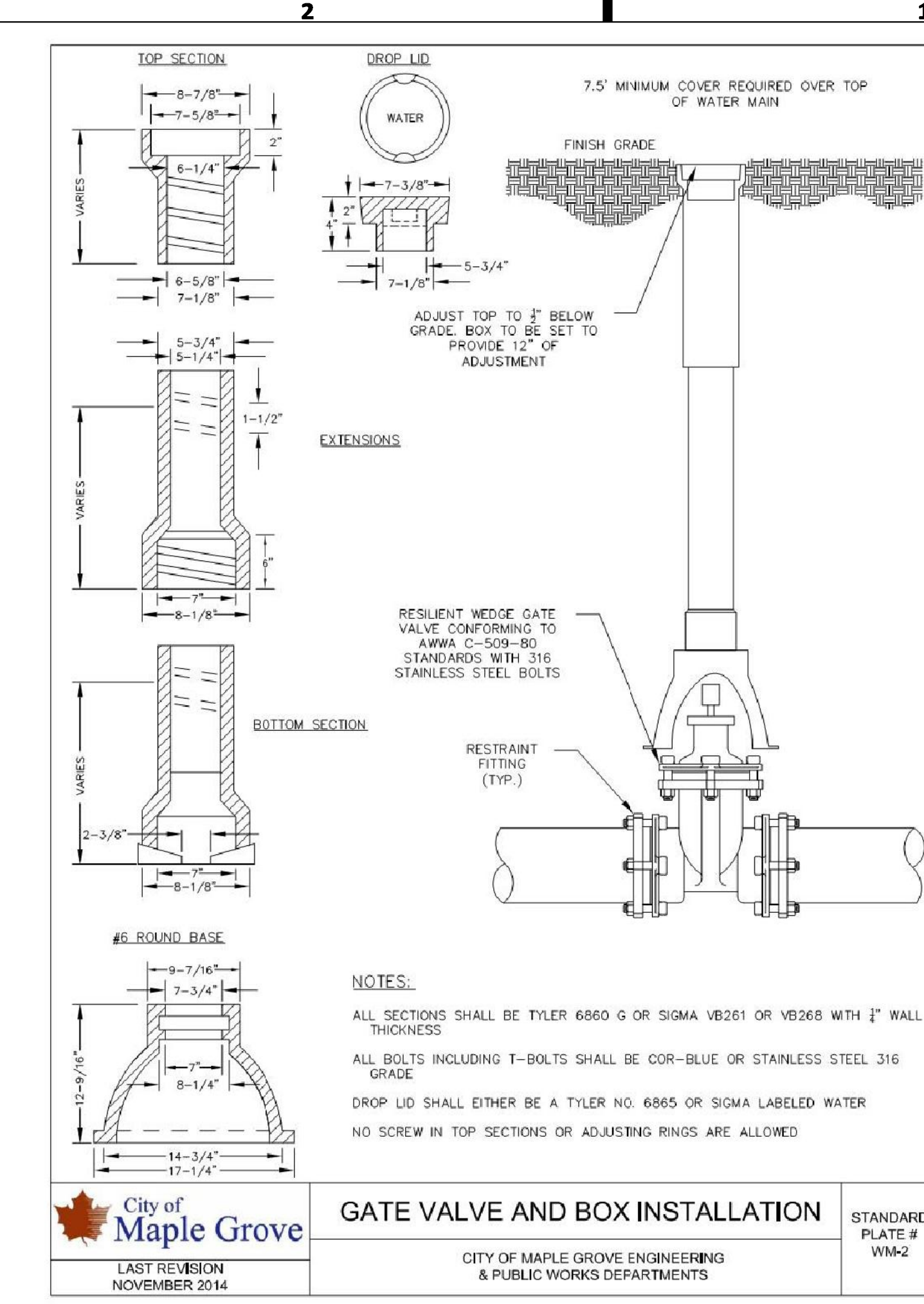

City of Maple Grove
LAST REVISION NOVEMBER 2014

GATE VALVE AND BOX INSTALLATION
CITY OF MAPLE GROVE ENGINEERING & PUBLIC WORKS DEPARTMENTS

STANDARD PLATE # WM-2

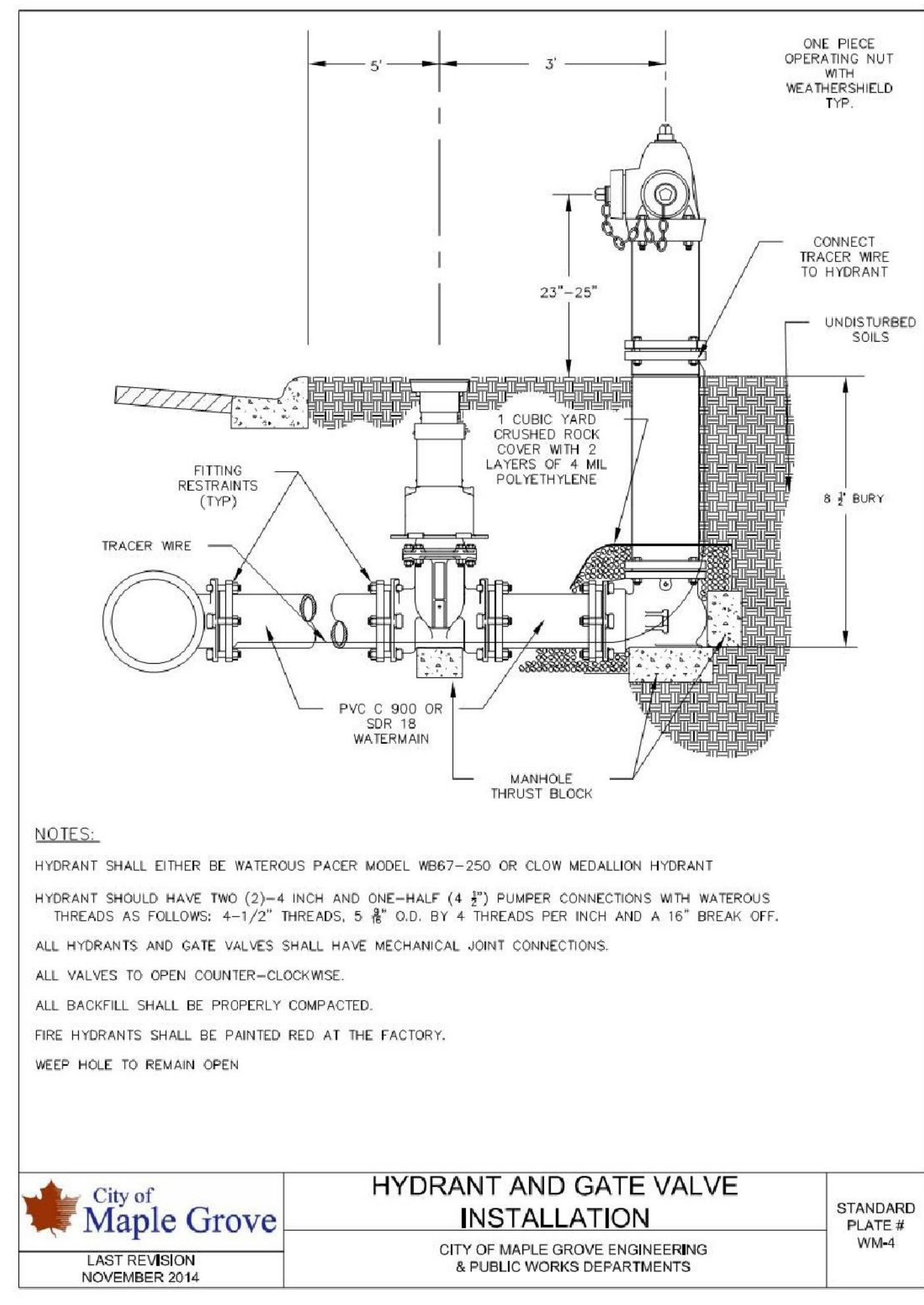

City of Maple Grove
LAST REVISION NOVEMBER 2014

HYDRANT AND GATE VALVE INSTALLATION
CITY OF MAPLE GROVE ENGINEERING & PUBLIC WORKS DEPARTMENTS

STANDARD PLATE # WM-4

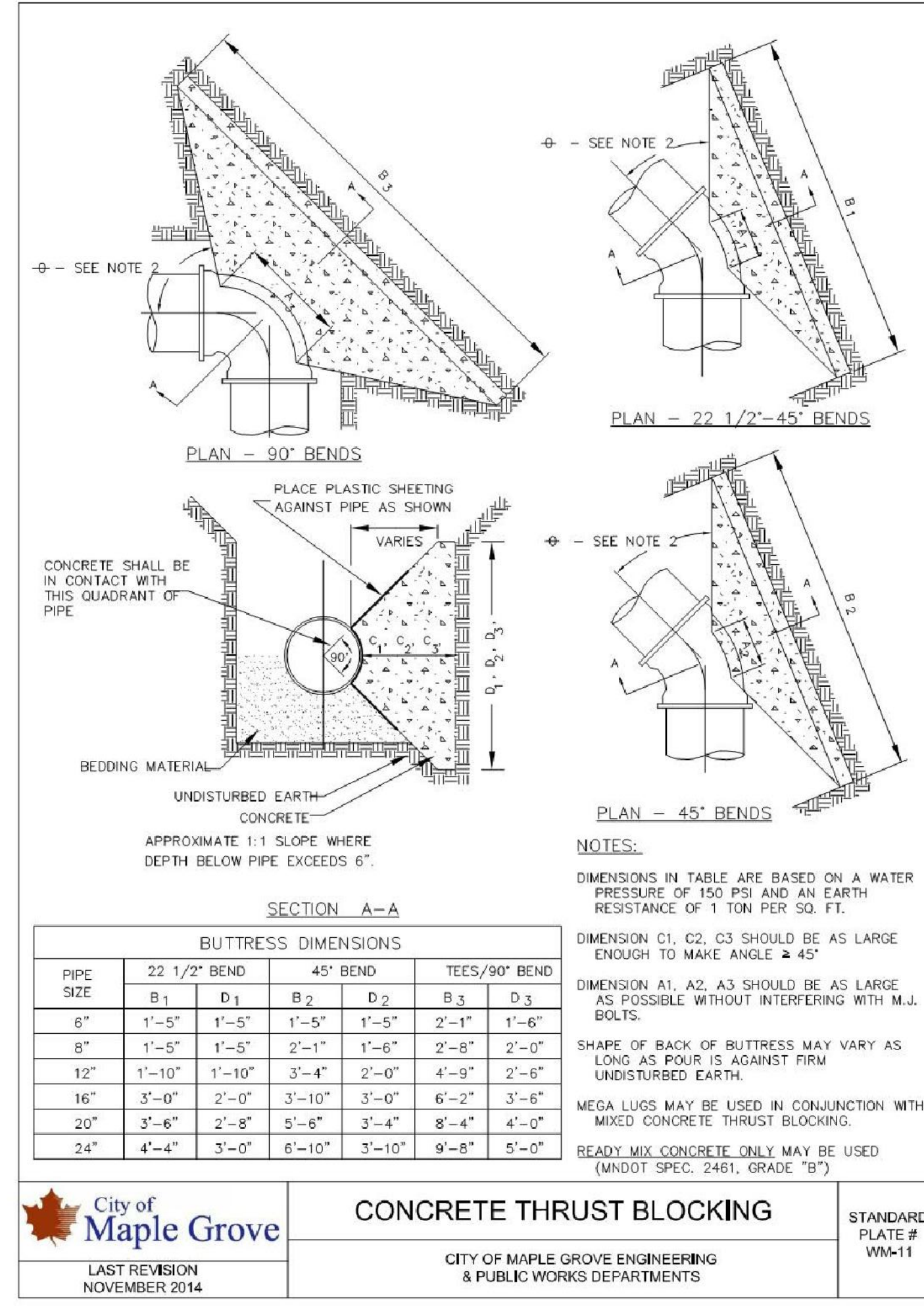

City of Maple Grove
LAST REVISION NOVEMBER 2014

CONCRETE THRUST BLOCKING
CITY OF MAPLE GROVE ENGINEERING & PUBLIC WORKS DEPARTMENTS

STANDARD PLATE # WM-11



322 1st Ave N, Suite #600
Minneapolis, MN 55401
phone 612.746.4260
facsimile 612.746.4754
www.jlgarchitects.com
copyright © 2016

I HEREBY CERTIFY THAT THIS SURVEY, PLAN, OR REPORT WAS PREPARED BY ME OR UNDER MY DIRECT SUPERVISION AND THAT I AM A DULY LICENSED ENGINEER UNDER THE LAWS OF THE STATE OF MINNESOTA.
Kevin E. Anderson
KEVIN E. ANDERSON
44223 12.04.2017
LIC. NO. DATE

REVISION SCHEDULE

NO.	DESCRIPTION	DATE

JLG ARCHITECTS
BOTTINEAU RIDGE II APARTMENTS
MAPLE GROVE, MN

DATE
12/04/2017

PHASE
100% CDs

PROJECT
16098

SHEET
C603
CIVIL DETAILS

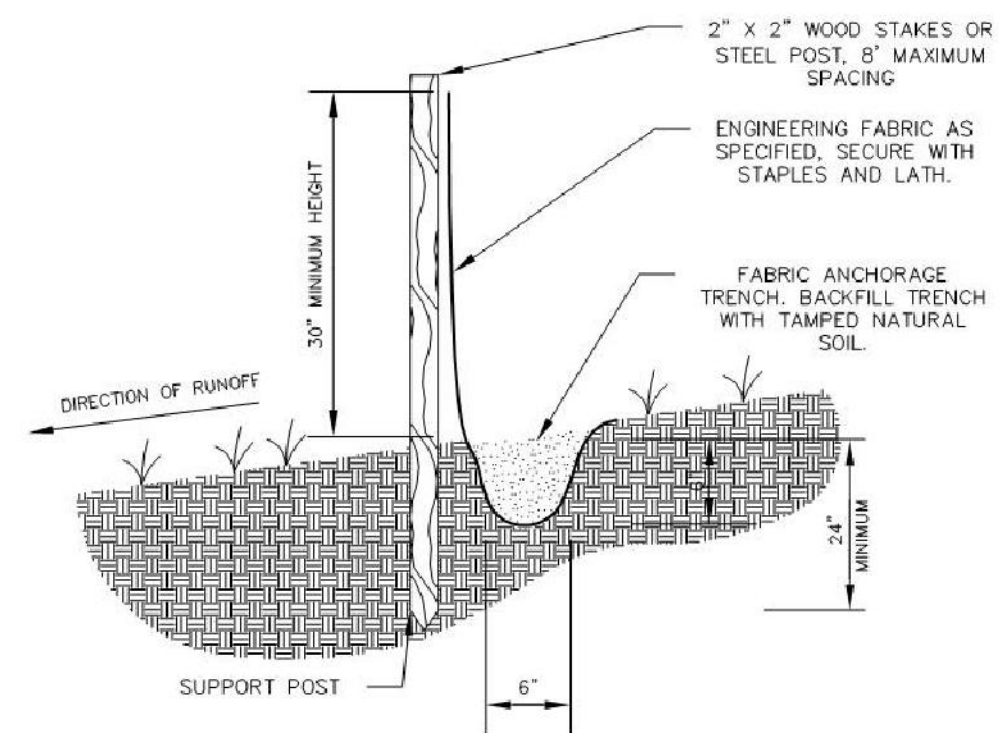

SILT FENCE

STANDARD PLATE # EROS-1

CITY OF MAPLE GROVE ENGINEERING & PUBLIC WORKS DEPARTMENTS

LAST REVISION NOVEMBER 2014

You created this PDF from an application that is not licensed to print to novaPDF printer (<http://www.novapdf.com>)

WMCO ROAD DRAIN OR APPROVED EQUAL

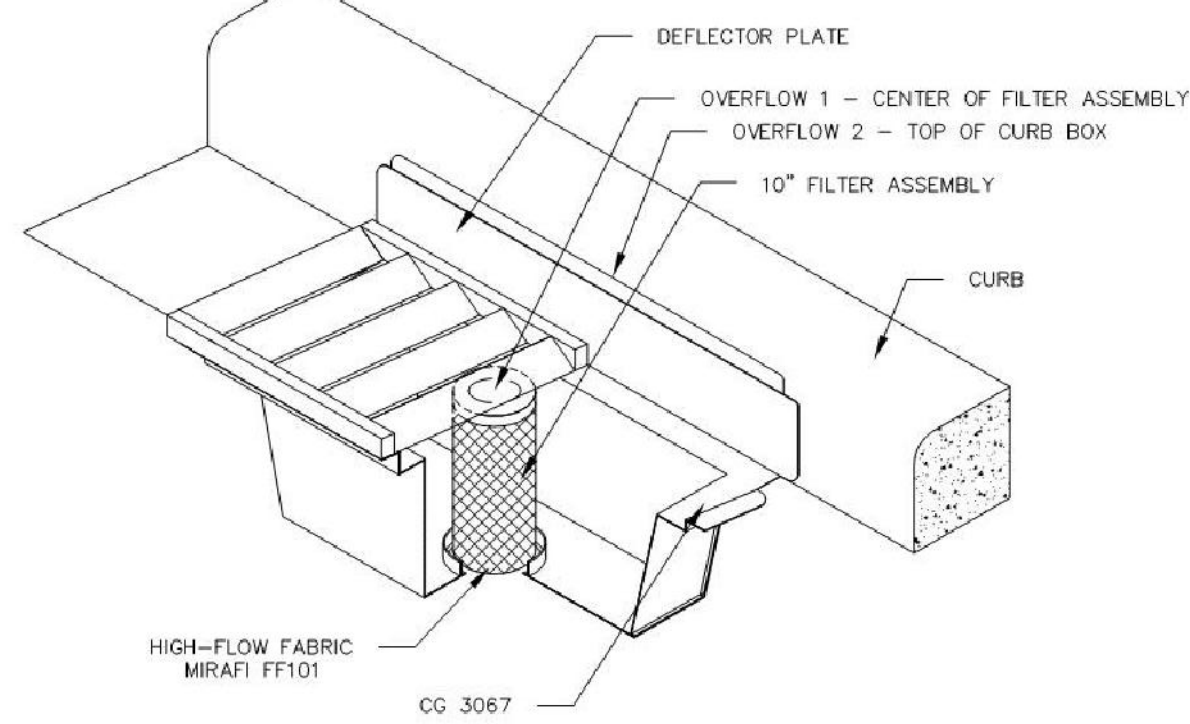

WMCO ROAD DRAIN OR APPROVED EQUAL

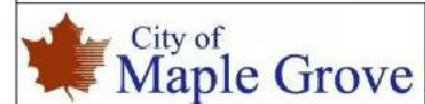
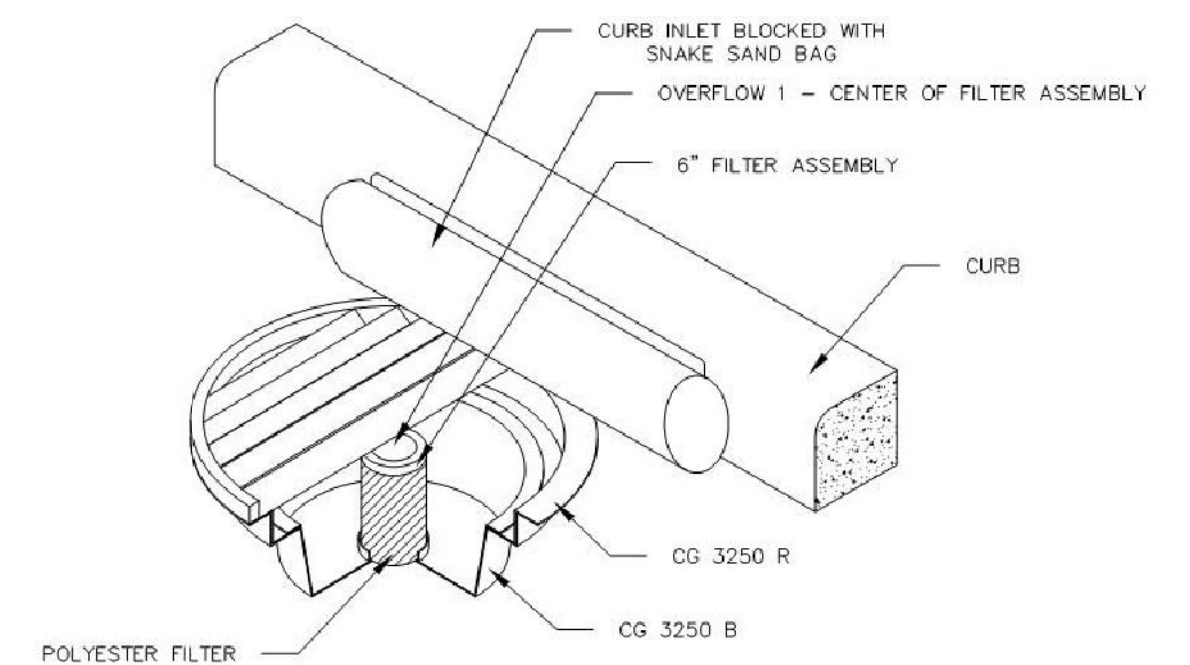

CURB INLET PROTECTIONS

STANDARD PLATE # EROS-19

CITY OF MAPLE GROVE ENGINEERING & PUBLIC WORKS DEPARTMENTS

LAST REVISION NOVEMBER 2014

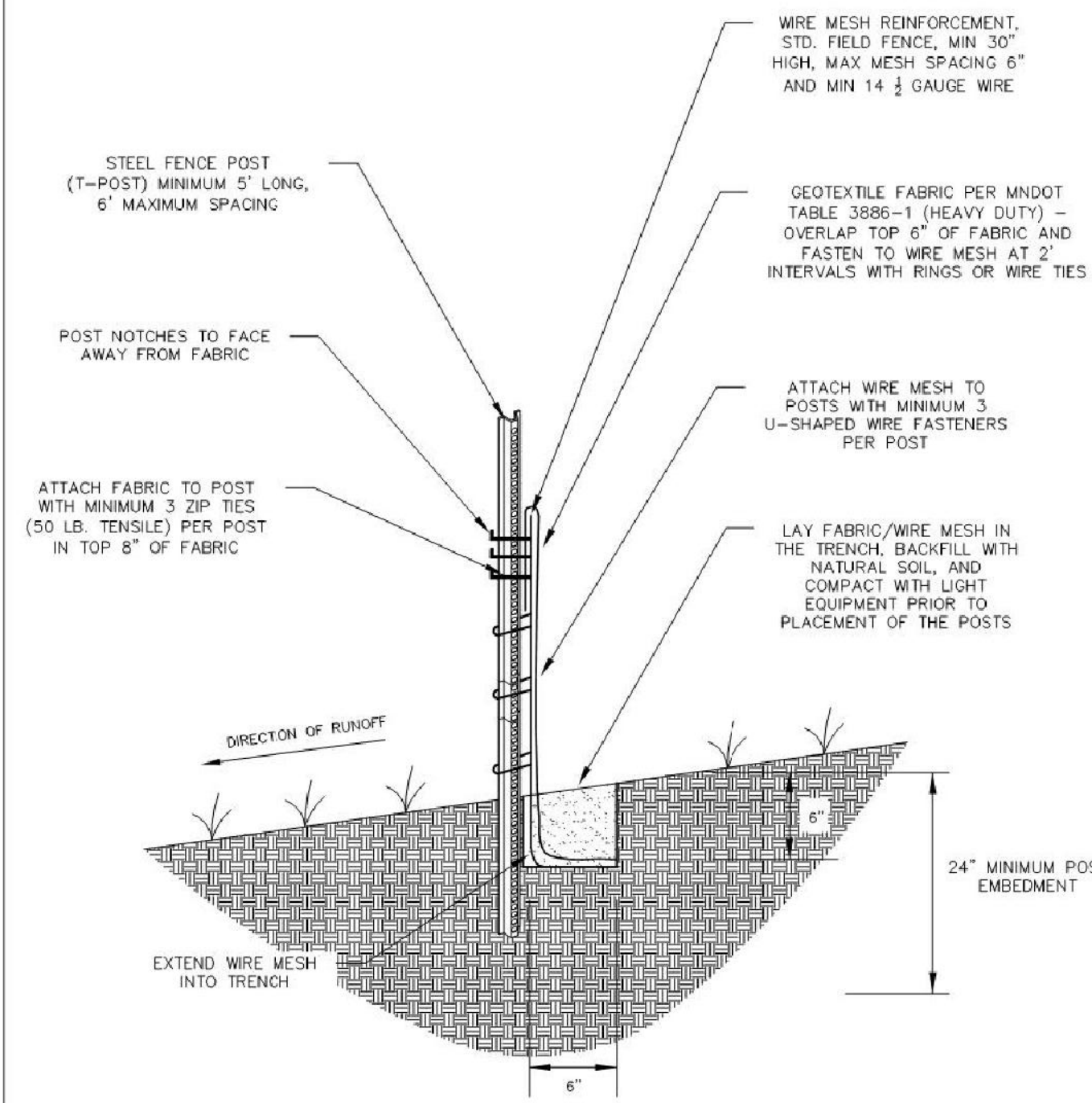

NOTES:

HEAVY DUTY SILT FENCE IS FOR USE ON SLOPES GREATER THAN OR EQUAL TO A 4:1 OR WITHIN 200 FT OF ANY TYPE OF WATER OR STREAM.



HEAVY DUTY SILT FENCE

STANDARD PLATE # EROS-2

CITY OF MAPLE GROVE ENGINEERING & PUBLIC WORKS DEPARTMENTS

LAST REVISION NOVEMBER 2014

You created this PDF from an application that is not licensed to print to novaPDF printer (<http://www.novapdf.com>)

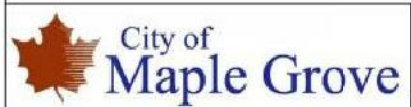
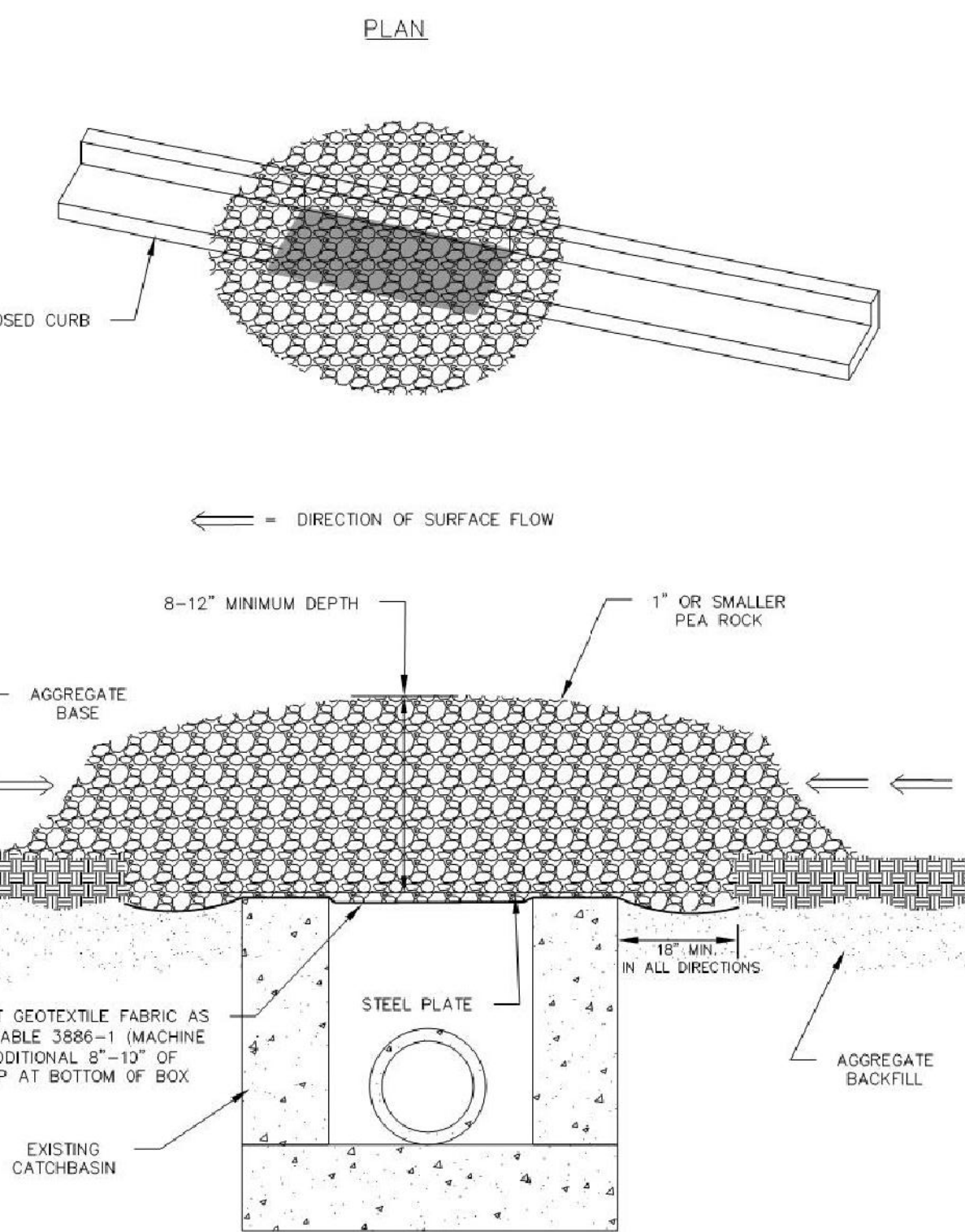

INLET PROTECTION ROCK FILTER FOR CATCH BASIN DURING ROAD CONSTRUCTION

STANDARD PLATE # EROS-7

CITY OF MAPLE GROVE ENGINEERING & PUBLIC WORKS DEPARTMENTS

LAST REVISION NOVEMBER 2014

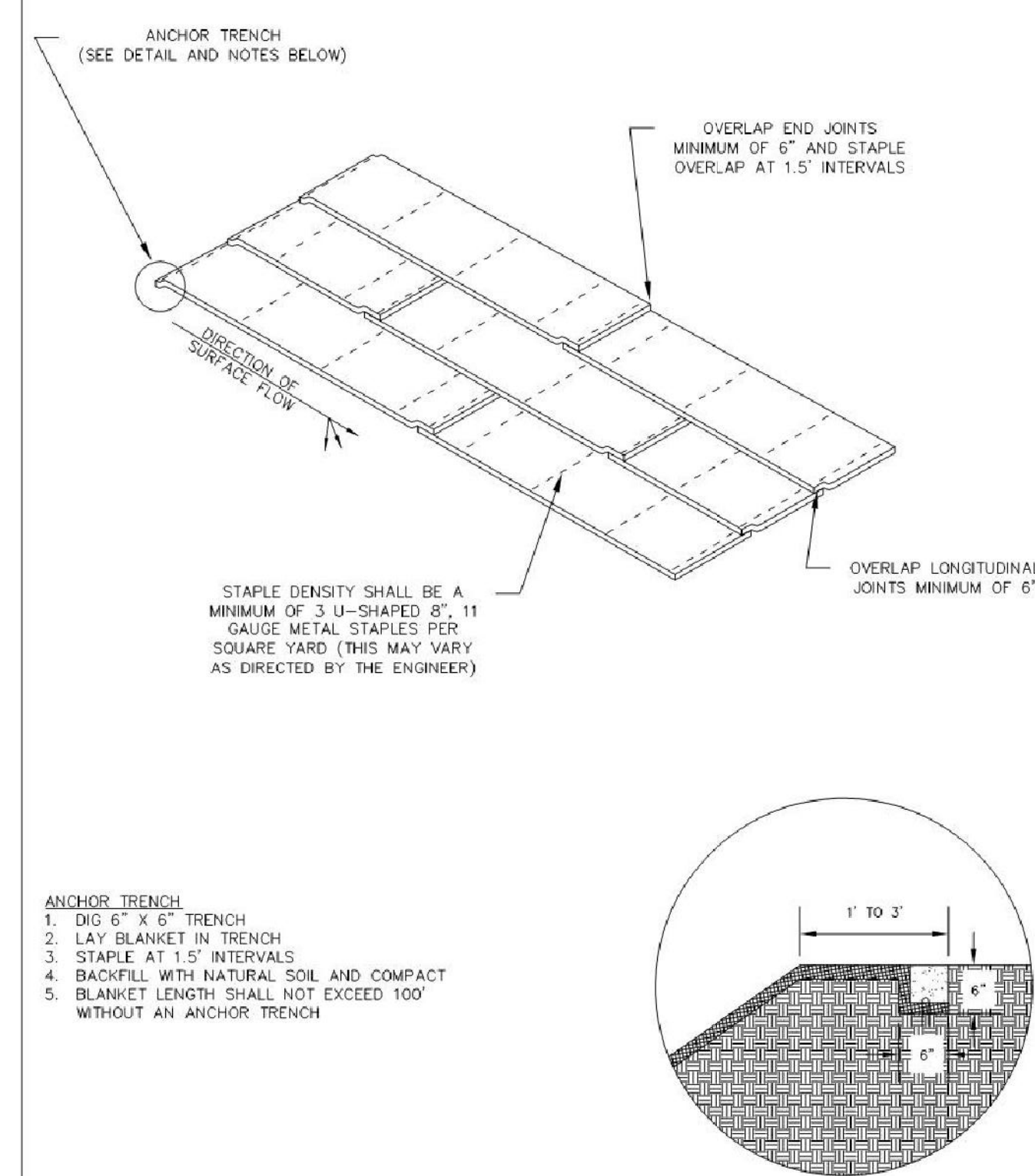

EROSION CONTROL BLANKET INSTALLATION

STANDARD PLATE # EROS-5

CITY OF MAPLE GROVE ENGINEERING & PUBLIC WORKS DEPARTMENTS

LAST REVISION NOVEMBER 2014

You created this PDF from an application that is not licensed to print to novaPDF printer (<http://www.novapdf.com>)

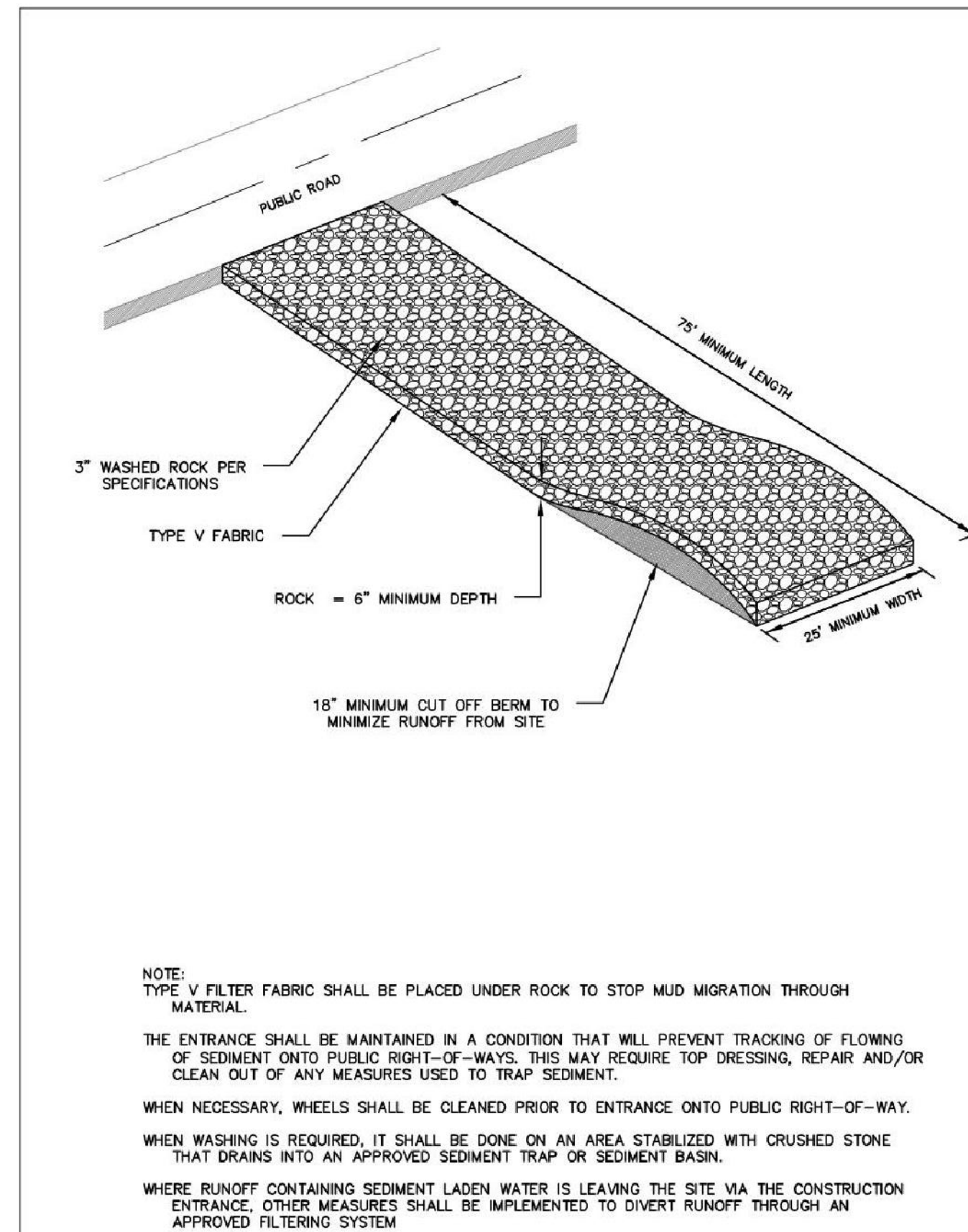

CONSTRUCTION ROCK ENTRANCE

STANDARD PLATE # EROS-13

CITY OF MAPLE GROVE ENGINEERING & PUBLIC WORKS DEPARTMENTS

LAST REVISION NOVEMBER 2014

You created this PDF from an application that is not licensed to print to novaPDF printer (<http://www.novapdf.com>)



322 1st Ave N, Suite #600
 Minneapolis, MN 55401
 phone 612.746.4260
 facsimile 612.746.4754
 www.jlgarchitects.com
 copyright © 2016

I HEREBY CERTIFY THAT THIS SURVEY, PLAN, OR REPORT WAS PREPARED BY ME OR UNDER MY DIRECT SUPERVISION AND THAT I AM A DULY LICENSED ENGINEER UNDER THE LAWS OF THE STATE OF MINNESOTA.

Ray E. Anderson
 RAY E. ANDERSON
 44223 12/04/2017
 LIC. NO. DATE

REVISION SCHEDULE

NO.	DESCRIPTION	DATE

JLG ARCHITECTS
BOTTINEAU RIDGE II APARTMENTS
 MAPLE GROVE, MN

DATE
 12/04/2017

PHASE
 100% CDs

PROJECT
 16098

SHEET
C604
 EROSION CONTROL
 DETAILS

Project Description:

The work on the project includes constructing a new apartment complex as the second part to Bottineau Ridge Apartments in Maple Grove, MN. The project includes the construction of a new building, concrete sidewalks, new playground, sanitary sewer piping, water service piping and the installation of storm sewer piping and structures to a newly constructed infiltration basin. The project is located east of the cul-de-sac of 80th Ave. N. and west of Hemlock Lane (Co. Rd. 61) in Maple Grove, MN.

Receiving Waters:

A major portion of the stormwater runoff is collected within an existing low area on site, and another portion is collected within the development's storm sewer collection system. The development's regional pond facility has been sized to treat runoff from future impervious areas within the development. All stormwater runoff from proposed improvements will be collected on-site, and routed to the development's storm sewer collection system, and ultimately into the regional pond facility.

Responsible Parties:

The Owner and the Contractor are responsible co-permittees for the implementation of the SWPPP. The Contractor and Owner shall apply for the NPDES Construction General Permit within 24 hours of award of Contract. The complete application must be submitted 30 days prior to start of construction activity. The Contractor is responsible for installation, inspection, maintenance, and repair of all erosion prevention and sediment control BMPs before, during, and after active construction. The Contractor shall amend the SWPPP before beginning construction to include the chain of responsibility of all operators on the site, or if not known, the title or position of the responsible party. The Contractor is responsible for identifying a person knowledgeable and experienced in the application of erosion prevention and sediment control BMPs who will oversee the implementation of the SWPPP before and during construction until the construction project is complete, the entire site has undergone Final Stabilization, and an NOT has been submitted the MPCA. The owner must identify who will be responsible for the long-term operations and maintenance of all permanent stormwater management systems. The Contractor is liable until final stabilization of all disturbed areas is achieved and the Notice of Termination (NOT)/ Permit Modification form is submitted to the MPCA (as specified in the NPDES construction permit). Once the identity of Responsible Parties is known, the SWPPP must be amended to include this information in the area below.

Project Engineer

Jeremy E. Anderson, PE
Design Tree Engineering, Inc.
120 17th Ave. W.
Alexandria, MN 56308
(320)762-1290, ext. 104
jea@designtreeengineering.com

Owner

Contractor

TBD

SWPPP Amendments:

The Owner or Contractor must amend the SWPPP as necessary to include additional requirements, such as additional or modified BMPs that are designed to correct problems identified or address situations whenever:

- 1. There is a change in design, construction, operation, maintenance, weather or seasonal conditions that has a significant effect on the discharge of pollutants to surface water or underground waters.
- 2. Inspections or investigations by site owner or operators, USEPA or MPCA officials indicate the SWPPP is not effective in eliminating or significantly minimizing the discharge of pollutants to surface waters or underground waters or that the discharges are causing water quality standard exceedances.
- 3. The SWPPP is not achieving the general objectives of minimizing pollutants in stormwater discharges associated with construction activity, or the SWPPP is not consistent with the terms and conditions of this permit.
- 4. At any time after the permit coverage is effective, the MPCA deems necessary.

Construction Notes:

Construction shall be governed by MnDOT and City of Maple Grove's Specifications, special provisions, amendments and the project specifications and detail plates. Permits and maps relating to this project's SWPPP can be found in the Project Manual. The Contractor shall keep the inspection and maintenance log and NPDES permit on-site at all time during active construction. Please refer to plans and specifications for additional SWPPP information.

Special Water, Impaired Water & TMDL Implementation Plans:

All disturbed areas not actively being worked must be stabilized within 14 days. The Owner is responsible for the long term maintenance of all infiltration basins and private storm sewer systems. Inlet protection, silt fences, final stabilization, and BMP's must be implemented prior to allowing any water runoff to be discharge off-site.

Calculations:

Area to be Disturbed = 2.75 AC
Pre-Construction Impervious Area = 0.07 AC
Post-Construction Impervious Area = 1.51 AC
Net Increase in Impervious Area = 1.44 AC

Sequence of Construction- NPDES Permit needed for this contract, requirements apply:

Contractor to verify that all applicable permits have been obtained and NPDES permit modification form has been submitted to MPCA 30 days prior to the start of construction.

- 1. The Contractor must plan for and implement appropriate construction phasing, vegetation buffer strips, horizontal slope grading, and other construction practices that minimize erosion. The location of areas not to be disturbed are shown on Plans.
- 2. The Contractor shall be responsible for full implementation of and maintenance required by the SWPPP Narrative until the Notice of Termination is approved by the MPCA.
- 3. The Contractor shall construct Erosion and Sediment Control BMPs in the following construction sequence:
 - a. Install rock construction entrances where indicated in the Plans.
 - b. Install silt fence where indicated in the Plans.
 - c. Install silt fence around proposed infiltration and bioretention BMPs to protect soils from compaction.
 - d. Locate Portable toilets on flat surfaces away from drainage paths. Stake in areas susceptible to high winds.
 - e. Construct concrete washout area and provide signage
 - f. Establish Waste Control Areas
 - g. Construct temporary sediment basins where 10 acres or more drain to one location. (Infiltration Basin 3 and 4 may be used as temporary basins).
 - h. Construct diversions to sediment basins.
 - i. Rough Grade Site.
 - j. Leave disturbed area of site in a roughened condition to limit erosion. Temporarily stabilize areas that will be inactive for a period of 7 or more days.
 - k. Install storm drainage system and place inlet protection as each inlet is installed.
 - l. Protect and repair BMPs, as necessary.
 - m. Perform street sweeping as needed.
 - n. Temporarily stabilize areas not be actively worked.
 - o. Site construction (Paving, Sidewalks, Buildings, etc.)
 - p. Final Grading.
 - q. Final site restoration (seeding, planting).
 - r. Remove temporary basins when permanent cover has reduced the acreage of disturbed soil to less than ten (10) acres draining to a common location.
 - s. Construct stormwater infiltration basins & bioretention basins only when contributing drainage area has been constructed and fully stabilized.
 - t. Remove Erosion Control Devices upon site establishment in accordance with NPDES Notice of Termination.

Erosion Control Maintenance and Inspection: BMP inspection and maintenance Responsible Party _____

- 1. Inspect erosion control devices and provide routine maintenance as follows:
 - a. Inspect erosion control a minimum of once per week and after each rain event measuring 0.5 inches or more. Record inspections on MPCA inspection log sheet.
 - (1) Records of each inspection and maintenance activity shall include:
 - Date and Time of inspections
 - Name of person(s) conducting inspection
 - Findings of inspection, including recommendations for corrective actions
 - Corrective actions taken (including dates, times, and party completing maintenance activities.
 - Date and amount of all rainfall events greater than 0.5" in 24 hours
 - Documentation of changes made to the SWPPP as required by the NPDES General Stormwater Permit for Construction Activity
 - (2) Inspections are not required where the ground is frozen.
 - (3) Rainfall amounts must be obtained by a properly maintained rain gauge installed onsite, or by a weather station that is within one mile or by a weather reporting system.
 - (3) any discharges that occur during the inspection(s) must be described in writing and photographed.
- 2. Provide Maintenance for all devices as follows:
 - a. Silt fences and erosion control devices at storm sewer inlets shall be inspected for depth of sediment, tears, to see if fabric is securely attached to support posts or structure, and to see that posts and devices are securely in place.
 - b. Silt fences, erosion control devices at storm sewer inlets and other erosion control devices shall be cleaned when sediment reached 1/3 of the height of the erosion control device, within 24 hours.
 - c. Rock Construction Entrances shall be inspected for clogging of river rock. River rock that has become clogged with sediment shall be removed and replaced with fresh river rock.
 - d. Repairs or replacement of all erosion control devices shall occur within 24 hours of discovery.
 - e. Temporary sediment basins shall be cleaned when sediment reached 1/2 of the outlet's height or half of the basins storage volume. The basin shall be drained and sediment removed within 72 hours.
 - f. Temporary diversion berms shall be inspected and any breaches promptly repaired.
 - g. Tracked sediment from construction vehicles onto public streets and paved areas (including paved areas on the construction site) shall be removed within 24 hours of discovery.
 - h. The bottom and side slopes of proposed storm water treatment basins shall be stabilized within 200 feet of property lines or point of discharges to any surface water, including; curb and gutter, pavement, storm sewer, swales, or other similar storm conveyance devices.
 - i. Removal of sediment and restabilization of surface waters shall be accomplished within 7 days of discovery.

Pollution Prevention Management Measures

- 1. Storage, Handling, and Disposal of Construction Products, Materials and Wastes: The Contractor shall comply with the following to minimize the exposure to stormwater of any of the products, materials, or wastes/ Products or wastes which are either not a source of contamination to stormwater or are designed to be exposed to stormwater are not held to this requirement:
 - a. Building products that have the potential to leach pollutants must be under cover (e.g. plastic sheeting or temporary roofs) to prevent the discharge of pollutants or protected by a similarly effective means designed to minimize contact with stormwater
 - b. Pesticides, herbicides, insecticides, fertilizers, treatment chemicals, and landscape materials must be under cover (e.g., plastic sheeting or temporary roofs) to prevent the discharge of pollutants or protected by similarly effective means designed to minimize contact with stormwater.
 - c. Hazardous materials, toxic waste, (including oil, diesel fuel, gasoline, hydraulic fluids, paint solvents, petroleum-based products, wood preservatives, additives, curing compounds, and acids) must be properly stored in sealed containers to prevent spills, leaks or other discharge. Restricted access storage areas must be provided to prevent vandalism. Storage and disposal of hazardous waste or hazardous materials must be in compliance with Minn. R. Ch 7045 including secondary containment as applicable.
 - d. Solid waste must be stored, collected and disposed of properly in compliance with Minn. R. ch. 7035.
 - e. Portable toilets must be positioned so that they are secure and will not be tipped or knocked over. Sanitary waste must be disposed of properly in accordance with Minn. R. ch. 7041.
- 2. Fueling and Maintenance of Equipment or Vehicles; Spill Prevention and Response: The Contractor shall take reasonable steps to prevent the discharge of spilled or leaked chemicals, including fuel, from any areas where chemicals or fuel will be loaded or unloaded including the use of drip pans or absorbents unless infeasible. The contractor must conduct fueling in a contained area unless infeasible. The Contractor must ensure adequate supplies are available at all times to clean up discharged materials and that an appropriate disposal method is available for recovered spilled materials. The Contractor must report and clean up spills immediately as required by Minn. Stat. §115.061, using dry clean up measures where possible.
- 3. Vehicle and Equipment Washing: If the Contractor washes the exterior of vehicles or equipment on the project site, washing must be limited to a defined area of the site. Runoff from the washing area must be contained in a sediment basin or other similarly effective controls and a waste from the washing activity must be properly disposed of.
- 4. The Contractor must properly use and store soaps, detergents, or solvents.
- 5. No engine degreasing is allowed on site.
- 6. Concrete and other washouts waste: The Contractor must provide effective containment for all liquid and solid wastes generated by washout operations (concrete, stucco, paint, form release oils, curing compounds and other construction materials) related to the construction activity. The liquid and solid washout wastes must not contact the ground, and the containments must be designed so that it does not result in runoff from the washout operations or areas. Liquid and solid wastes must be disposed of properly and in compliance with MPCA rules. A sign must be installed adjacent to each washout facility that requires site personnel to utilize the proper facilities for disposal of concrete and other washout wastes.

Dewatering and Basin Draining:

Dewatering or basin draining that may have turbid or sediment laden discharge water must be discharged to a temporary or permanent sedimentation basin on the project site whenever possible. Discharge from the temporary or permanent sedimentation basin must be visually checked to ensure adequate treatment is obtained in the basin and nuisance conditions, impacts to wetlands, and erosion in receiving channels or on downslope properties will not result from the discharge. Adequate sedimentation control measures are required for discharge water that contains suspended solids.

If using filters with backwash water, either haul the backwash water away for disposal, return the backwash water to the beginning of the treatment process, or incorporate the backwash water into the site in a manner that does not erode into runoff.

Timing of BMP Installation:

The Erosion and Sediment Control BMPs shall be installed as necessary to minimize erosion from disturbed surfaces and capture sediment on site and shall meet the NPDES permit Part IV construction activity requirements. Perimeter controls shall be placed prior to the start of any construction. All disturbed areas not actively being worked must be stabilized within 7 days.

Storm Water Pollution Prevention Plan:

The Permittees must implement the entire SWPPP and the requirements of the NPDES permit. The BMPs identified in the SWPPP and in the permit must be selected, installed and maintained in an appropriate and functional manner that is in accordance with manufacturer specifications and accepted engineering practices.

Contacts		
AGENCY	NAME	PHONE NUMBER
City of Maple Grove	Engineering Department	(763)-494-6350
DNR Waters	Janelle Miersch	(218) 739-7576 ext. 232
ACOE	St. Paul Office	(651) 290-5375
State Duty Officer	MPCA	(800)422-0798
SWPPP Designer	Riley Kephart	(320) 762-1290 ext. 109
Erosion Control Review	Jeremy E. Anderson, PE	(320) 762-1290 ext. 104
Erosion Control Supervisor	TBD	

LOCATION OF SWPPP REQUIREMENTS		
DESCRIPTION	TITLE	SHEET # OR SPECIFICATION SECTION
RECEIVING SURFACE WATER	N/A	N/A
Final Stabilization	Erosion Control Plan	C501
Drainage Plans	Site Grading and Utility Plan	C301-C401
Drainage Details	Details	C601-C604
Erosion Control Sheets	Erosion Control Plan	C501
Erosion Control Details	Details	C604
Erosion & Sediment Control Quantities	Erosion Control Plan	C501



322 1st Ave N, Suite #600
Minneapolis, MN 55401
phone 612.746.4260
facsimile 612.746.4754
www.jlgarchitects.com
copyright © 2016

I HEREBY CERTIFY THAT THIS SURVEY, PLAN, OR REPORT WAS PREPARED BY ME OR UNDER MY DIRECT SUPERVISION AND THAT I AM A DULY LICENSED ENGINEER UNDER THE LAWS OF THE STATE OF MINNESOTA.
JEREMY E. ANDERSON
44223 12.04.2017
LIC. NO. DATE

REVISION SCHEDULE

NO.	DESCRIPTION	DATE
-----	-------------	------

JLG ARCHITECTS
BOTTINEAU RIDGE II APARTMENTS
MAPLE GROVE, MN

DATE
12/04/2017

PHASE
100% CDs

PROJECT
16098

SHEET
C605
SWPPP
NARRATIVE