

SHEET INDEX

1	SITE PLAN
2	EROSION CONTROL
3	EROSION CONTROL DETAILS
4	GRADING AND DRAINAGE PLAN
5	UTILITY PLAN
6-7	GRADING DETAILS
8-13	MnDOT STANDARD PLANS

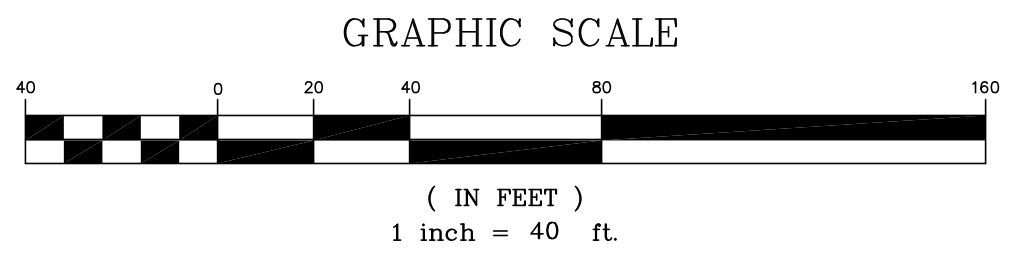
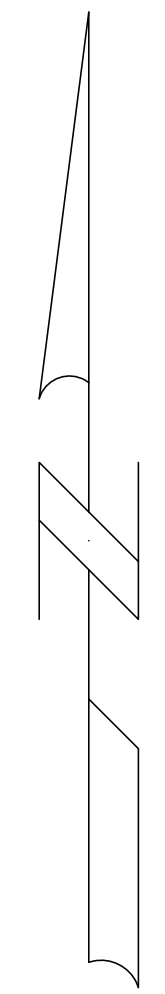

PROPOSED LAND USE - EACH PHASE

LOT 1 - PHASE 1
 108 HOMES
 107 GARAGE PARKING
 85 SURFACE PARKING
 192 TOTAL PARKING SPACES
 1.78 TOTAL PARKING RATIO
 201,246 TOTAL LOT AREA
 94,890 SQ. FT.. IMPERVIOUS SURFACE
 106,356 SQ. FT.. GREEN SPACE
 47% IMPERVIOUS SURFACE
 53% GREEN SPACE

LOT 2 - PHASE 2
 78 HOMES
 78 GARAGE PARKING
 74 SURFACE PARKING
 152 TOTAL PARKING SPACES
 1.95 TOTAL PARKING RATIO
 136,177 TOTAL LOT AREA
 79,140 SQ. FT.. IMPERVIOUS SURFACE
 57,037 SQ. FT.. GREEN SPACE
 58% IMPERVIOUS SURFACE
 42% GREEN SPACE

PROPOSED LAND USE

186 HOMES
 185 GARAGE PARKING
 159 SURFACE PARKING
 344 TOTAL PARKING SPACES
 1.85 TOTAL PARKING RATIO
 337,423 TOTAL PARCEL AREA
 174,030 SQ. FT.. IMPERVIOUS SURFACE
 166,393 SQ. FT.. GREEN SPACE
 52% IMPERVIOUS SURFACE
 48% GREEN SPACE

FUTURE ACCESS ROAD 24' WIDE F-F
 CONSTRUCT CONSTRUCTION ACCESS ROAD
 12' WIDE BITUMINOUS, WITH 2% CROSS SLOPE
 14' WIDE CLASS 5, 8" THICK WITH 2" THICK BITUMINOUS

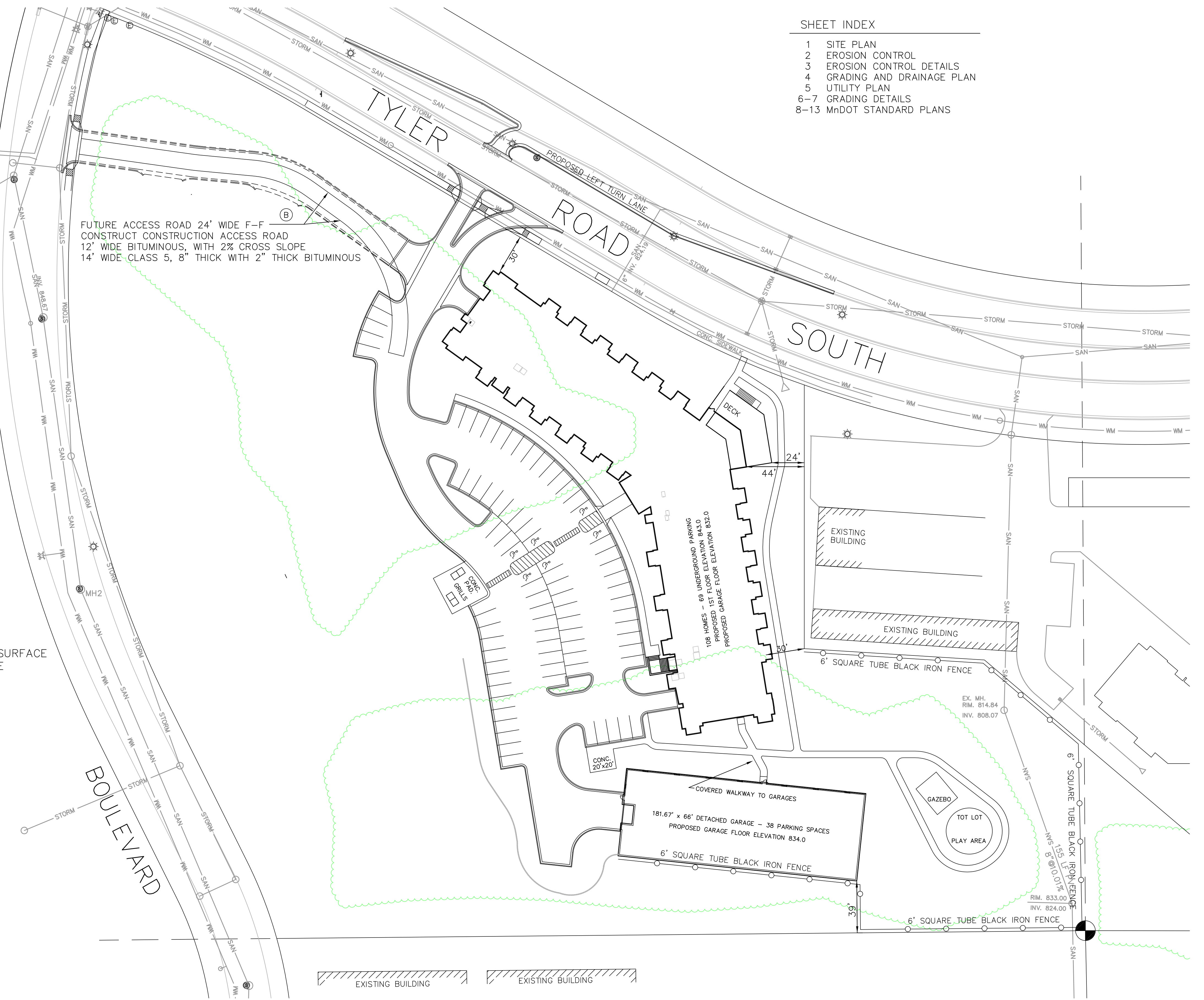

G³ G-Cubed Inc.
 Engineering
 Surveying
 Planning

285 Westview Drive
 West Saint Paul, MN 55118
 ph. 651.288.1100 fax 651.455.4948

I HEREBY CERTIFY THAT THIS PLAN, SPECIFICATION, OR REPORT WAS PREPARED BY ME OR UNDER MY DIRECT SUPERVISION AND I AM A DULY LICENSED PROFESSIONAL ENGINEER UNDER THE LAWS OF THE STATE OF MINNESOTA

Mark Welch
 DATE _____ REG. NO. _____

DESIGNED	DJT
DRAWN	
CHECKED	

REVISED	BY	DATE
(A)	DJT	1/9/2019
(B)	DJT	1/28/2019

LATEST REVISION: 1-28-2019
 Prepared For:
 Andy Baartman
 1489 Hay Creek Valley Rd
 Red Wing, MN 55066

FILE NO.: 07124 Baartman

CITY OF RED WING
 GOODHUE COUNTY, MINNESOTA
 2018 CONSTRUCTION

PARK PLACE
 APARTMENTS

SITE
 PLAN

SHEET 1 OF 13 SHEETS

(A) ADDED TEMP BASINS, DITCH BLOCKS, MOVED 3' SUMP TO STM1 AND TYLAR RD. WORK BY OTHERS, AND REMOVED PHASE 2 SIDEWALK IN HEWITT R/W.
 (B) REMOVED PHASE 2, REVISED RETAINING WALL AND GRADES, TEMP BASIN#1, ADDED CONST. ACCESS RD. AND REVISED ROAD GRADE

GOVERNING SPECIFICATIONS

THE MOST RECENT EDITION OF THE MINNESOTA DEPARTMENT OF TRANSPORTATION "STANDARD SPECIFICATIONS FOR CONSTRUCTION", SUBJECT TO ANY AMENDMENTS & THE 2013 EDITION OF THE "STANDARD UTILITIES SPECIFICATIONS" AS PER THE CITY ENGINEER'S ASSOCIATION OF MINNESOTA SHALL GOVERN. AND THE CITY OF RED WING ENGINEERING DESIGN MANUAL.

PLACE AND MAINTAIN STRAW BALE DITCH BLOCKS AS DIRECTED BY THE CITY

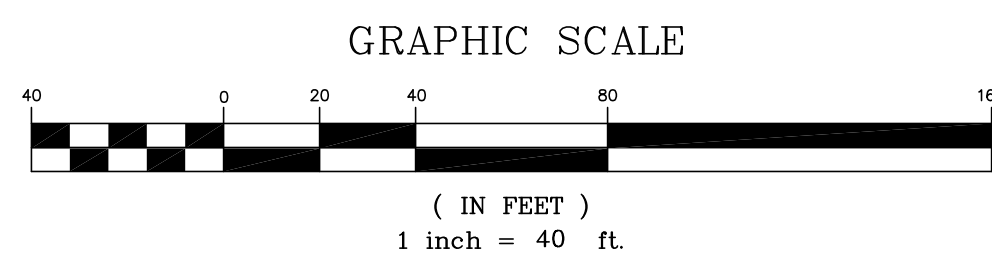

- DENOTES EROSION CONTROL INLET PROTECTION AND BALE CHECK
- DENOTES EROSION CONTROL BALE CHECK

GRADING NOTES:

- 1.) ALL EROSION CONTROL MEASURES SHALL MEET AND/OR EXCEED THE MPCA NPDES PERMIT AND THE CITY OF RED WING, STORM WATER MANAGEMENT REQUIREMENTS.
- 2.) SILT FENCE, CONSTRUCTION ENTRANCE, PONDING BASINS, PERIMETER DRAINAGE SWALES ARE TO BE CONSTRUCTED FIRST.
- 3.) ALL GRADING SHALL BE CONDUCTED IN A MANNER TO MINIMIZE THE POTENTIAL FOR SITE EROSION.
- 4.) SPREAD 4" TOPSOIL SEED AND MULCH OVER THE ENTIRE SITE EXCEPT PONDS, AND PHASE ONE STREET AND UTILITY AREAS.
- 5.) CITY OF RED WING INSPECTOR MAY BE PRESENT DURING SOIL TESTING, TEST ROLLING IS REQUIRED.
- 6.) A TEMPORARY STAGING STOCKPILE, AND BORROW SHALL BE MAINTAINED AND CONTROLLED.
- 7.) ALL BUILDING PAD AREAS SHALL BE INSPECTED AND APPROVED BEFORE FILL PLACEMENT.
- 8.) RETAINING WALLS MUST BE DESIGNED BY AN ENGINEER AND APPROVED BY THE CITY ENGINEER PRIOR TO CONSTRUCTION.

EROSION CONTROL NOTES:

- 1.) PLACE EROSION CONTROL PROTECTION AT ALL STORM SEWER INLETS AND WHERE DIRECTED BY THE ENGINEER.
- 2.) PLACE SILT FENCE WHERE SHOWN ON PLANS AND AS DIRECTED BY THE ENGINEER.
- 3.) SEED, FERTILIZE AND MULCH ALL DISTURBED AREAS EXCEPT ROADWAYS.
 - A.) TEMPORARY SEED MIXTURE SHALL BE WHEAT, RYE, OATS OR REGREEN AT 100 LBS/ACRE.
 - B.) PERMANENT SEED MIXTURE SHALL BE #500 AT 100 LBS/ACRE.
 - B.) MULCH SHALL BE MNDOT TYPE 1 MULCH AT 2 TONS/ACRE.
 - C.) FERTILIZER SHALL BE 25-5-10 AT 200 LBS/ACRE.
- 4.) MPCA STORM WATER PERMIT IS REQUIRED FOR THIS PROJECT.
- 5.) EROSION CONTROL IS TO BE PROVIDED IN ACCORDANCE WITH THE PROJECT'S STORM WATER POLLUTION PREVENTION PLAN (SWPPP)
- 6.) SILT FENCE, CONSTRUCTION ENTRANCE, PONDING, DRAINAGE SWALES ARE TO BE CONSTRUCTED FIRST.
- 7.) ADDITIONAL EROSION CONTROL MEASURES SHALL BE REQUIRED IN AREAS, IF AN EROSION PATTERN OCCURS.
- 8.) APPLY WATER AS NEEDED AND AS DIRECTED BY THE ENGINEER TO CONTROL DUST.
- 9.) ALL AREAS DISTURBED DURING CONSTRUCTION SHALL BE RESTORED AS SOON AS POSSIBLE. AREAS THAT HAVE BEEN DISTURBED OR ARE AT FINISHED GRADE, BUT HAVE NO ACTIVE GRADING, SHALL BE SEEDED AND MULCHED WITHIN 14 DAYS, EXCEPT ON SLOPES STEEPER THAN 4H:1V. SLOPES 3H:1V OR STEEPER SHALL BE SEEDED AND COVERED WITH AN EROSION CONTROL BLANKET OR SEEDED AND MULCHED WITH A TACKIFYING AGENT (GLUE IMPREGNATED PAPER MULCH SHALL NOT BE USED).

TEMP. BASIN #1
 TOP 844.0
 BOTTOM 839.0
 10' WIDE EMERGENCY OVERFLOW
 FLOWS TO TEMP. BASIN #2
 RIPRAP PROTECTED WEIR
 OUTLET EL. 843.5

TEMP. BASIN #2
 TOP 834.0
 BOTTOM 826.0
 EMERGENCY OVERFLOW EL. 834.0
 CB #16 RIM EL. 832.75
 15 LF 6" PVC INV 824.0
 2.5" FAIRCLOTH SKIMMER
 10 YR. EL. 832.47
 100 YR EL. 833.23

GENERAL NOTES
 PLACE EROSION CONTROL BLANKET OR
 SOD ON SLOPES OVER 3:1
 * TEMPORARY BASINS MEET 2YR DESIGN REQUIREMENT

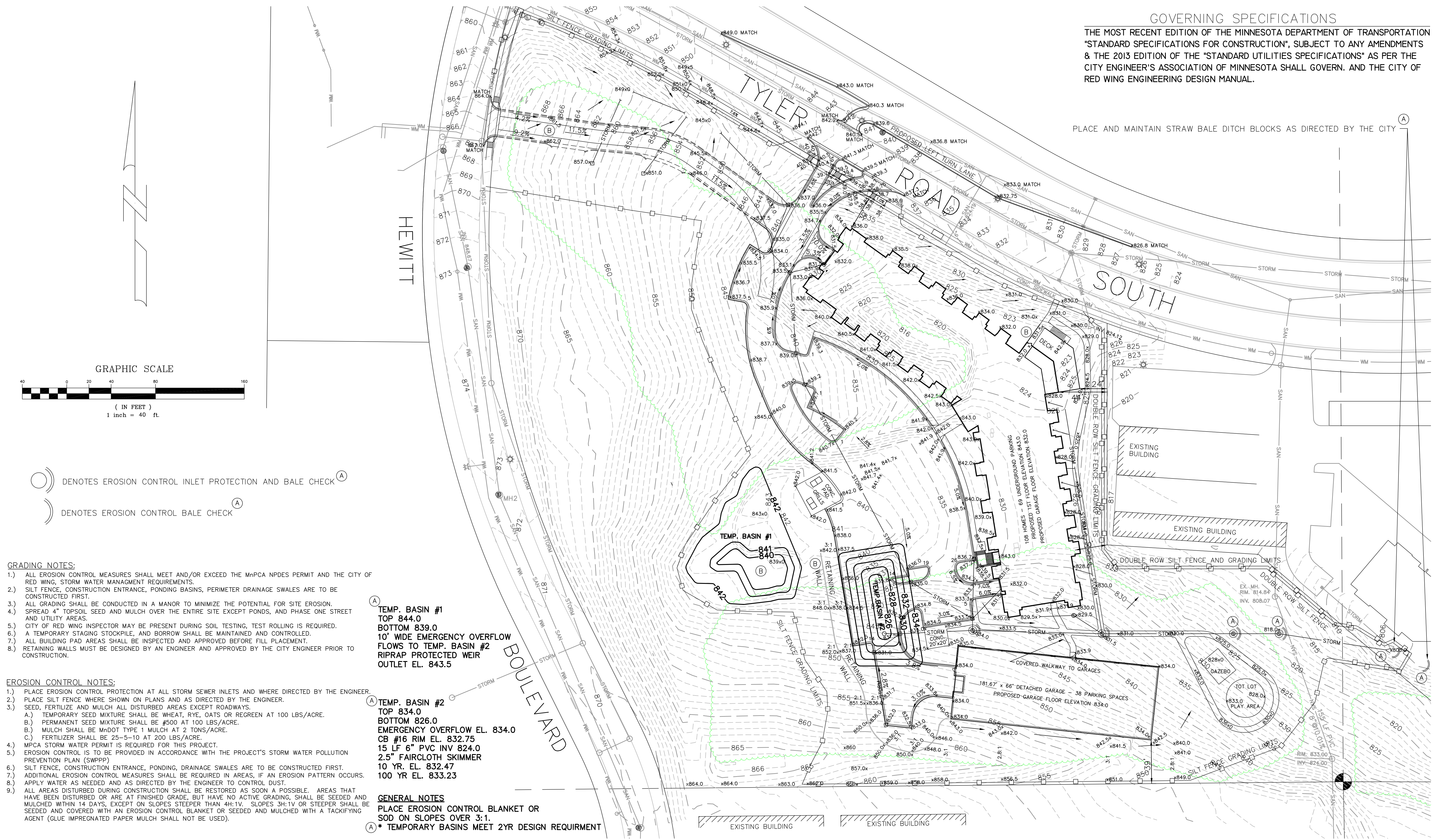

G³ G-Cubed Inc.
 Engineering
 Surveying
 Planning

285 Westview Drive
 West Saint Paul, MN 55118
 ph. 651.288.1100 fax 651.455.4948

Mark Welch
 DATE _____ REG. NO. _____

DESIGNED	DJT
DRAWN	
CHECKED	

REVISED	BY	DATE
(A)	DJT	1/9/2019
(B)	DJT	1/28/2019

LATEST REVISION: 1-28-2019
 Prepared For:
 Andy Baartman
 1489 Hay Creek Valley Rd
 Red Wing, MN 55066
 FILE NO.: 07124 Baartman

CITY OF RED WING
 GOODHUE COUNTY, MINNESOTA
 2018 CONSTRUCTION

PARK PLACE
 APARTMENTS

EROSION CONTROL
 PLAN

SHEET 2 OF 13 SHEETS

- (A) ADDED TEMP BASINS, DITCH BLOCKS, MOVED 3' SUMP TO STMH 1 AND TYLER RD. WORK BY OTHERS, AND REMOVED PHASE 2 SIDEWALK IN HEWITT R/W.
- (B) REMOVED PHASE 2, REVISED RETAINING WALL AND GRADES, TEMP BASIN#1, ADDED CONST. ACCESS RD. AND REVISED ROAD GRADE

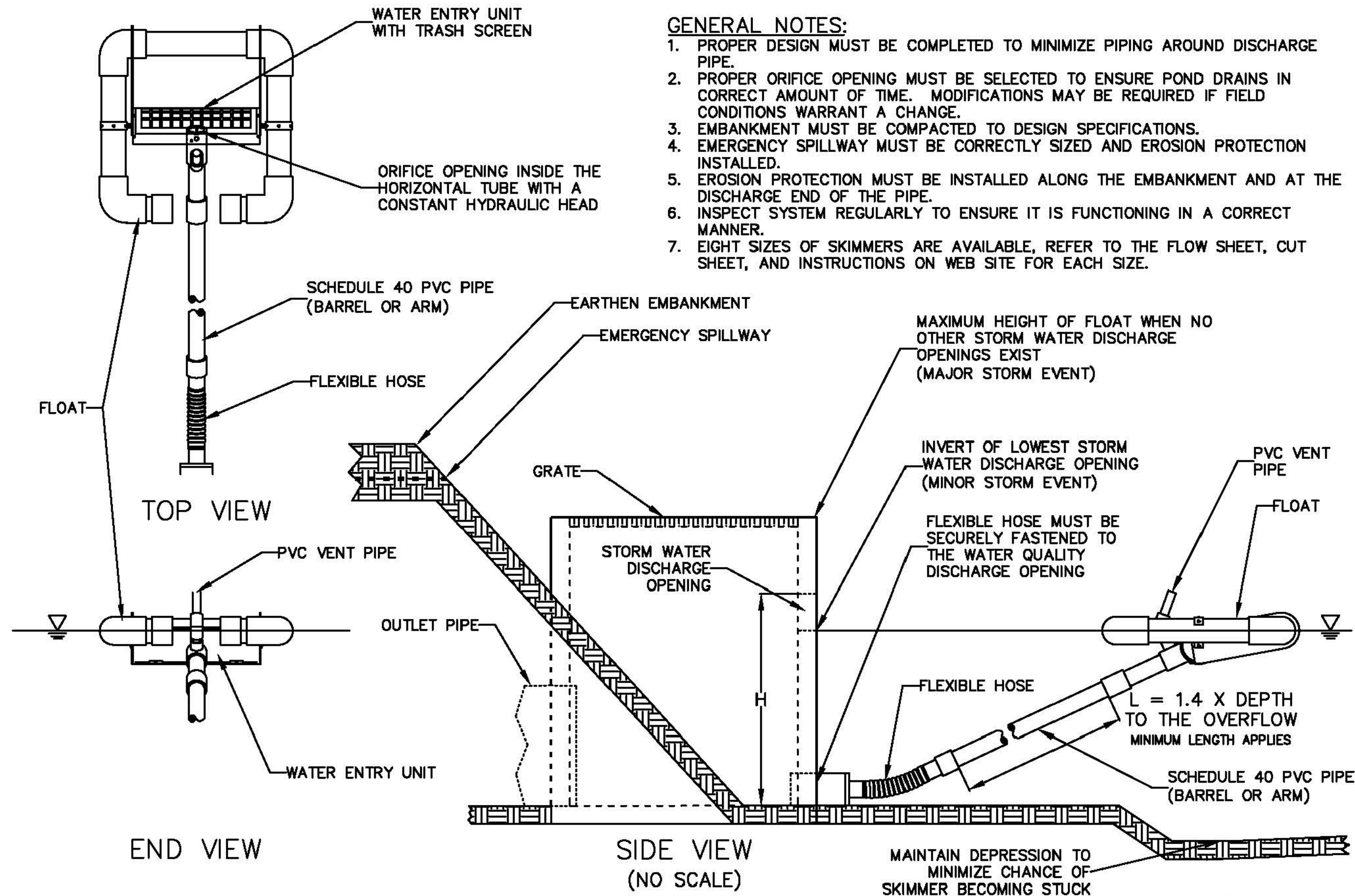

GENERAL NOTES:

1. PROPER DESIGN MUST BE COMPLETED TO MINIMIZE PIPING AROUND DISCHARGE PIPE.
2. PROPER ORIFICE OPENING MUST BE SELECTED TO ENSURE POND DRAINS IN CORRECT AMOUNT OF TIME. MODIFICATIONS MAY BE REQUIRED IF FIELD CONDITIONS WARRANT A CHANGE.
3. EMBANKMENT MUST BE COMPACTED TO DESIGN SPECIFICATIONS.
4. EMERGENCY SPILLWAY MUST BE CORRECTLY SIZED AND EROSION PROTECTION INSTALLED.
5. EROSION PROTECTION MUST BE INSTALLED ALONG THE EMBANKMENT AND AT THE DISCHARGE END OF THE PIPE.
6. INSPECT SYSTEM REGULARLY TO ENSURE IT IS FUNCTIONING IN A CORRECT MANNER.
7. EIGHT SIZES OF SKIMMERS ARE AVAILABLE, REFER TO THE FLOW SHEET, CUT SHEET, AND INSTRUCTIONS ON WEB SITE FOR EACH SIZE.

DRAWN BY T. R. EVANS 10/10

FAIRCLOTH SKIMMER® DISCHARGE SYSTEM WITH OUTLET STRUCTURE

J. W. FAIRCLOTH & SON INC.
 WWW.FAIRCLOTHSKIMMER.COM
 TELEPHONE: (919) 732-1244
 FAX: (919) 732-1286
 EMAIL: WARREN@FAIRCLOTHSKIMMER.COM

G³ G-Cubed Inc.
 Engineering
 Surveying
 Planning
 285 Westview Drive
 West Saint Paul, MN 55118
 ph. 651.288.1100 fax 651.455.4948

I HEREBY CERTIFY THAT THIS PLAN, SPECIFICATION, OR REPORT WAS PREPARED BY ME OR UNDER MY DIRECT SUPERVISION AND I AM A DULY LICENSED PROFESSIONAL ENGINEER UNDER THE LAWS OF THE STATE OF MINNESOTA.
 Mark Welch
 DATE _____ REG. NO. _____

DESIGNED	DJT
DRAWN	
CHECKED	

REVISED	BY	DATE
(A)	DJT	1/9/2019
(B)	DJT	1/28/2019

LATEST REVISION: 1-28-2019
 Prepared For:
 Andy Baartman
 1489 Hay Creek Valley Rd
 Red Wing, MN 55066
 FILE NO.: 07124 Baartman

CITY OF RED WING
 GOODHUE COUNTY, MINNESOTA
 2018 CONSTRUCTION

PARK PLACE
 APARTMENTS

EROSION CONTROL
 DETAILS
 SHEET 3 OF 13 SHEETS

(A) ADDED TEMP BASINS, DITCH BLOCKS, MOVED 3' SUMP TO STMH 1 AND TYLAR RD. WORK BY OTHERS, AND REMOVED PHASE 2 SIDEWALK IN HEWITT R/W.
 (B) REMOVED PHASE 2, REVISED RETAINING WALL AND GRADES, TEMP BASIN#1, ADDED CONST. ACCESS RD. AND REVISED ROAD GRADE

WARNING
 BEFORE DIGGING CALL GOPHER
 STATE ONE CALL FOR LOCATIONS.
 651-454-0002
 REQUIRED BY LAW

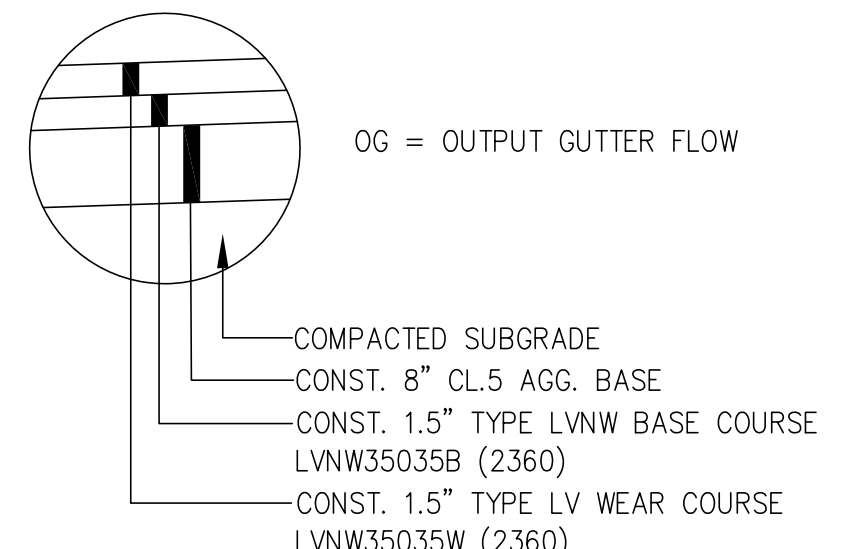
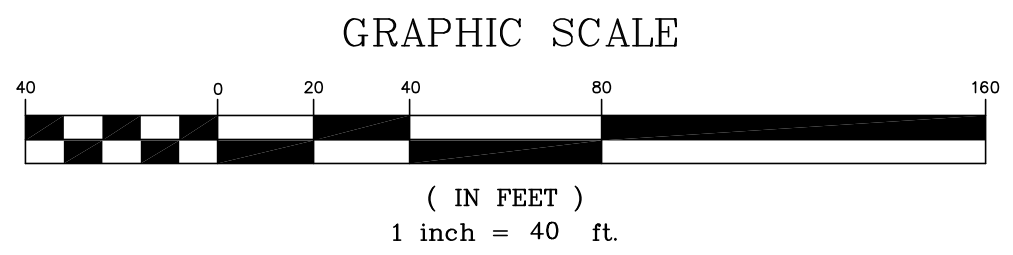
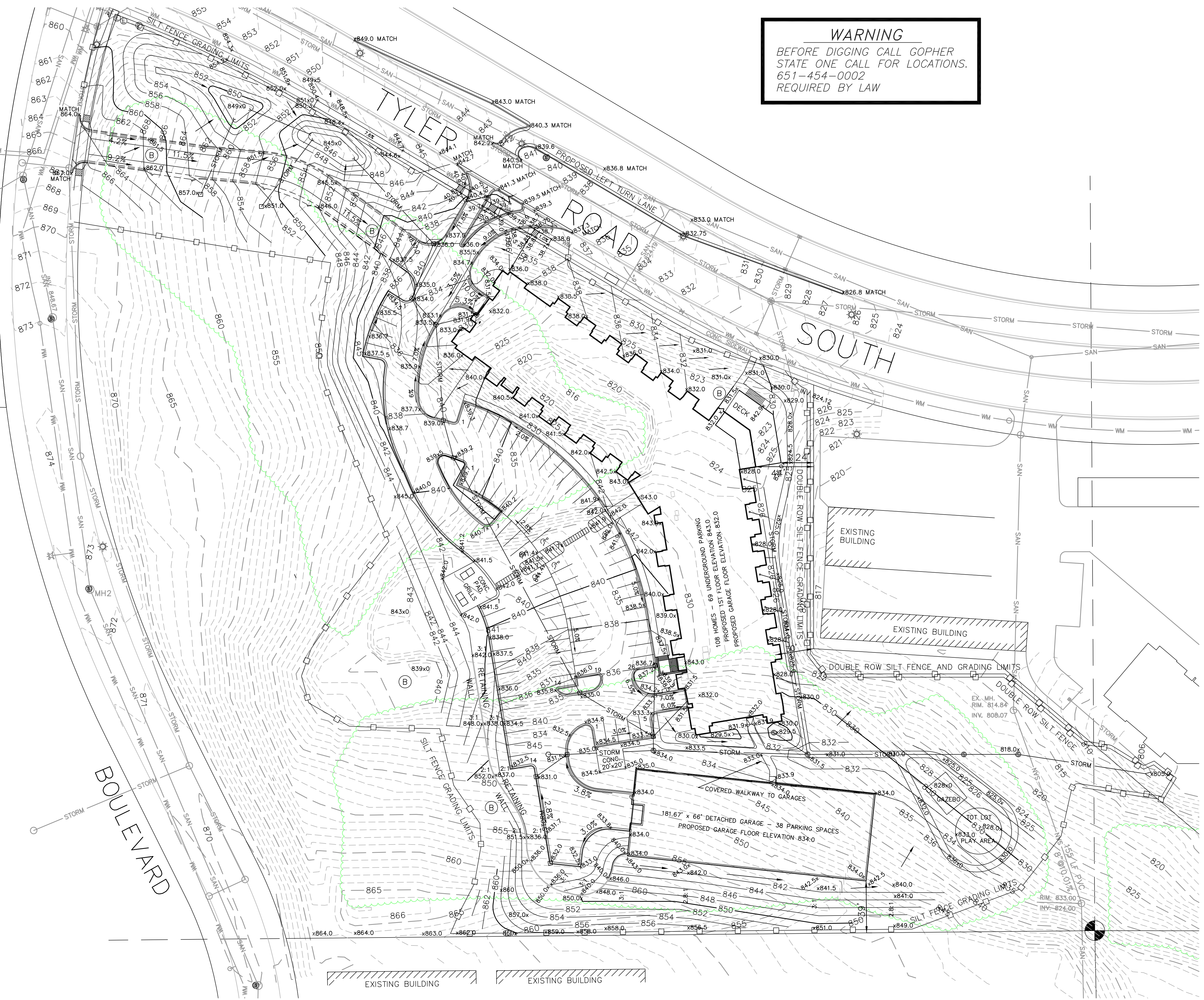

Paving Section – PARKING LOT
 CONSTRUCT B612 CONC. CURB AND GUTTER UNLESS OTHERWISE INDICATED.
 SIDEWALKS SHALL BE 4' WIDE – 4" THICK REINFORCED CONCRETE
 GARAGE APRONS SHALL BE 6' WIDE – 7" THICK REINFORCED CONCRETE.
 SIDEWALK ADJACENT PAVEMENT AREA SHALL HAVE 8" THICK EDGE

SIDEWALK NOTE:
 1.) CONSTRUCT ADA ACCESSIBLE PED. RAMPS AS PER CITY OF RED WING, STD. PLATE

GOVERNING SPECIFICATIONS
 THE MOST RECENT EDITION OF THE MINNESOTA DEPARTMENT OF TRANSPORTATION "STANDARD SPECIFICATIONS FOR CONSTRUCTION", SUBJECT TO ANY AMENDMENTS & THE 2013 EDITION OF THE "STANDARD UTILITIES SPECIFICATIONS" AS PER THE CITY ENGINEER'S ASSOCIATION OF MINNESOTA SHALL GOVERN. AND THE CITY OF RED WING ENGINEERING DESIGN MANUAL.

G³ G-Cubed Inc.
 Engineering
 Surveying
 Planning
 285 Westview Drive
 West Saint Paul, MN 55118
 ph. 651.288.1100 fax 651.455.4948

I HEREBY CERTIFY THAT THIS PLAN, SPECIFICATION, OR REPORT WAS PREPARED BY ME OR UNDER MY DIRECT SUPERVISION AND I AM A DULY LICENSED PROFESSIONAL ENGINEER UNDER THE LAWS OF THE STATE OF MINNESOTA
 Mark Welch
 DATE _____ REG. NO. _____

DESIGNED	DJT
DRAWN	
CHECKED	

REVISED	BY	DATE
(A)	DJT	1/9/2019
(B)	DJT	1/28/2019

LATEST REVISION: 1-28-2019
 Prepared For:
 Andy Baartman
 1489 Hay Creek Valley Rd
 Red Wing, MN 55066
 FILE NO.: 07124 Baartman

CITY OF RED WING
 GOODHUE COUNTY, MINNESOTA
 2018 CONSTRUCTION

PARK PLACE
 APARTMENTS

GRADING AND DRAINAGE
 PLAN
 SHEET 4 OF 13 SHEETS

- (A) ADDED TEMP BASINS, DITCH BLOCKS, MOVED 3' SUMP TO STMH 1 AND TYLAR RD. WORK BY OTHERS, AND REMOVED PHASE 2 SIDEWALK IN HEWITT R/W.
- (B) REMOVED PHASE 2, REVISED RETAINING WALL AND GRADES, TEMP BASIN#1, ADDED CONST. ACCESS RD. AND REVISED ROAD GRADE

GOVERNING SPECIFICATIONS

THE MOST RECENT EDITION OF THE MINNESOTA DEPARTMENT OF TRANSPORTATION "STANDARD SPECIFICATIONS FOR CONSTRUCTION", SUBJECT TO ANY AMENDMENTS & THE 2013 EDITION OF THE "STANDARD UTILITIES SPECIFICATIONS" AS PER THE CITY ENGINEER'S ASSOCIATION OF MINNESOTA SHALL GOVERN. AND THE CITY OF RED WING ENGINEERING DESIGN MANUAL.

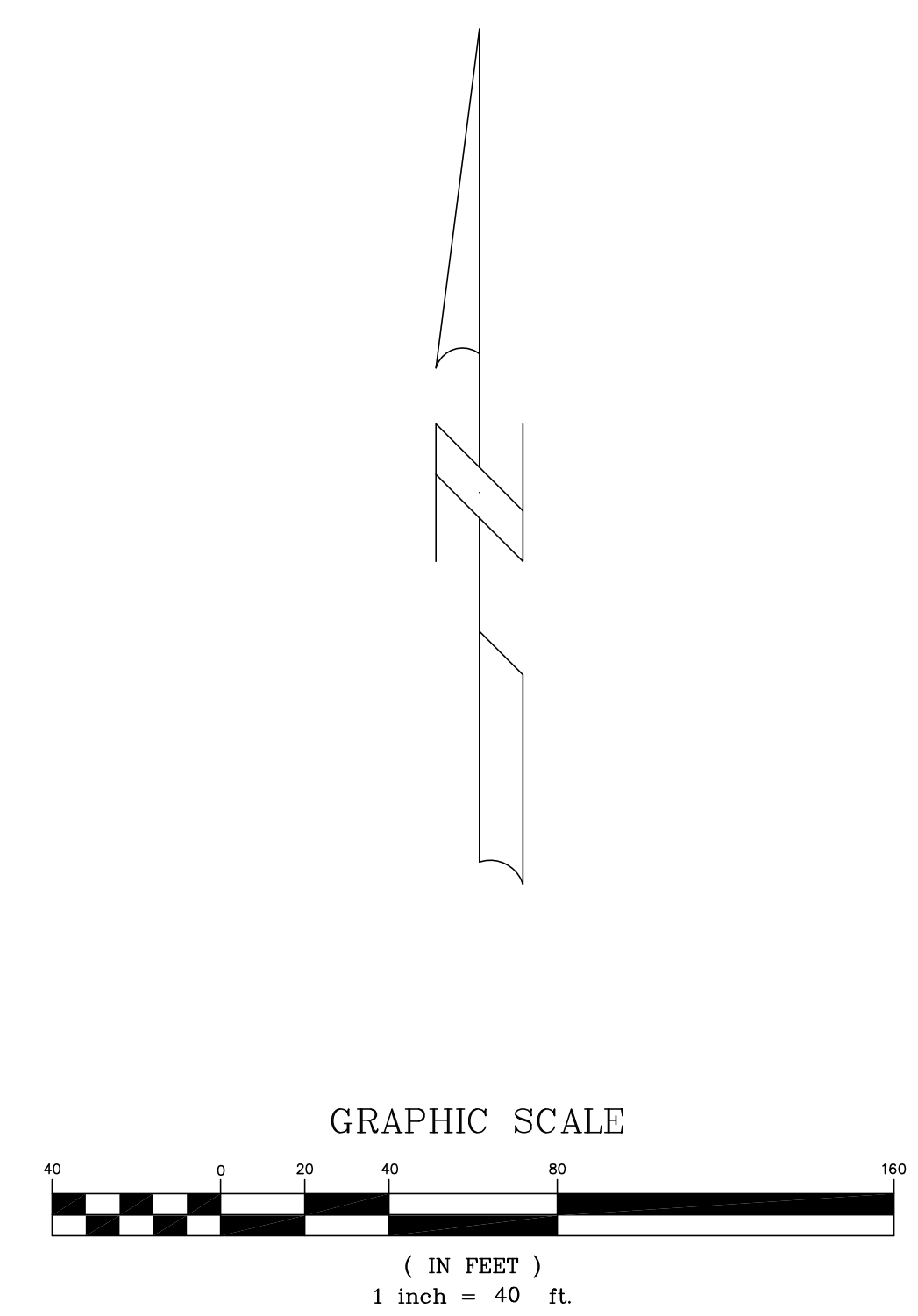

- UTILITY NOTE:**
 1.) ALL STORM SEWER SHALL BE HP-ADS PVC PIPE.
 2.) RIP RAP ALL APRON OUTLETS AS PER CITY OF RED WING STANDARD PLATE.
 3.) RIP RAP APRON 4, OVERSIZE RIP RAP BOWL FOR BOTH EXISTING AND PROPOSED APRON.
- DOWNSPOUT CONNECTION NOTE:**
 1.) CONNECT ALL DOWNSPOUTS BETWEEN CB NO. 15 AND MH NO. 2
 CONSTRUCT 8" HP-ADS PVC WITH 8"x12" WYES AND 8" RISERS NEXT TO BUILDING AND CAP. CUT HOLE IN CAP MATCHING DOWN SPOUT.
- SIDEWALK NOTE:**
 1.) CONSTRUCT ADA ACCESSIBLE PED. RAMPS AS PER CITY OF RED WING, STD. PLATE

Storm Sewer Construction Tabulation										
Structure Number	Structure Type	Casting Elevation	Outlet Elevation	Linear Footage	Pipe Size	Flow to Structure Number	Gradient Percent	Downstream Structure Inlet Elevation	Neenah Casting & Grates	Temp Basin
Bartman Apartments										
CB No. 1	Type 1 CB	857.00	852.00	62.00	12" HP-ADS PVC	OUTLET #1	4.03%	849.50	R-3067	
CB No. 2	Type 1 CB	851.00	846.00	65.00	12" HP-ADS PVC	OUTLET #3	0.77%	845.50	R-3067	
CB No. 6	Type 1 CB	836.00	830.00	44.65	12" HP-ADS PVC	CB NO.7	4.48%	828.00	R-3067	
CB No. 7	Type 1 CB	834.00	828.00	26.90	12" HP-ADS PVC	CB NO.8	2.01%	827.46	R-3067	
CB No. 8	Type 1 Drop CB	833.50	824.87	72.57	15" HP-ADS PVC	CB NO.10	2.00%	823.42	R-3067	
CB No. 9	Type 1 CB	831.50	825.50	31.41	12" HP-ADS PVC	CB NO.8	2.01%	824.87	R-3067	
CB No. 10	Type 1 CB	839.00	823.42	29.51	15" HP-ADS PVC	CB NO.11	2.00%	822.83	R-3067	
CB No. 11	Type 1 CB	839.20	822.83	202.02	15" HP-ADS PVC	CB NO.12	2.00%	818.78	R-3067	
CB No. 12	Type 1 CB	835.00	818.78	64.59	15" HP-ADS PVC	CB NO.13	2.00%	817.49	R-3067	
CB No. 13	Type 1 Drop CB	833.50	817.49	10.62	18" HP-ADS PVC	MH NO.1	1.98%	817.28	R-3067	
CB No. 14	Type 1 CB	836.70	830.70	53.66	12" HP-ADS PVC	CB NO.13	5.96%	827.50	R-3067	
CB No. 15	Cleanout Structure	825.50	822.25	201.13	12" HP-ADS PVC	MH NO.2	4.21%	813.78	R-3067	
CB No. 16	Type 1 CB	831.50	818.59	65.36	15" HP-ADS PVC	MH NO.1	2.00%	817.28	R-3067	15'-6" PVC Inv. 823.5
CB No. 17	Type 1 CB	831.00	819.17	28.98	12" HP-ADS PVC	CB NO.16	2.00%	818.59	R-3067	
CB No. 18	Type 1 CB	832.00	820.50	66.39	12" HP-ADS PVC	CB NO.17	2.00%	819.17	R-3067	
MH No. 1	Type 4 MH Drop-3' Sump	834.00	817.28	116.64	18" HP-ADS PVC	MH NO.2	3.00%	813.78	R-1916-C	
MH No. 2	Type 4 Drop MH	831.50	813.78	157.62	18" HP-ADS PVC	MH NO.3	3.00%	809.05	R-1916-C	
MH No. 3	Type 4 Drop-3' Sump	818.00	805.00	99.00	24" HP-ADS PVC	OUTLET #4	0.00%	805.00	R-1916-C	
Inlet #1	Type 4 MH	849.50	849.50	48.46	12" HP-ADS PVC	OUTLET #2	9.29%	845.00	R-1916-C	
Inlet #2	Type 4 MH	845.50	845.50	87.91	12" HP-ADS PVC	CB NO.6	17.63%	830.00	R-1916-C	
Inlet #3	Type 4 MH	829.50	823.50	31.16	12" HP-ADS PVC	INLET #4	1.99%	822.88	R-1916-C	
Inlet #4	Type 4 MH	829.50	822.88	30.37	12" HP-ADS PVC	MH NO.2	2.01%	822.27	R-1916-C	
Grate #1	Trench Grate	831.50	826.50	9.98	12" HP-ADS PVC	CB NO.9	10.02%	825.50		
Grate #2	Trench Grate	831.50	826.50	37.27	12" HP-ADS PVC	CB NO.13	5.37%	824.50		

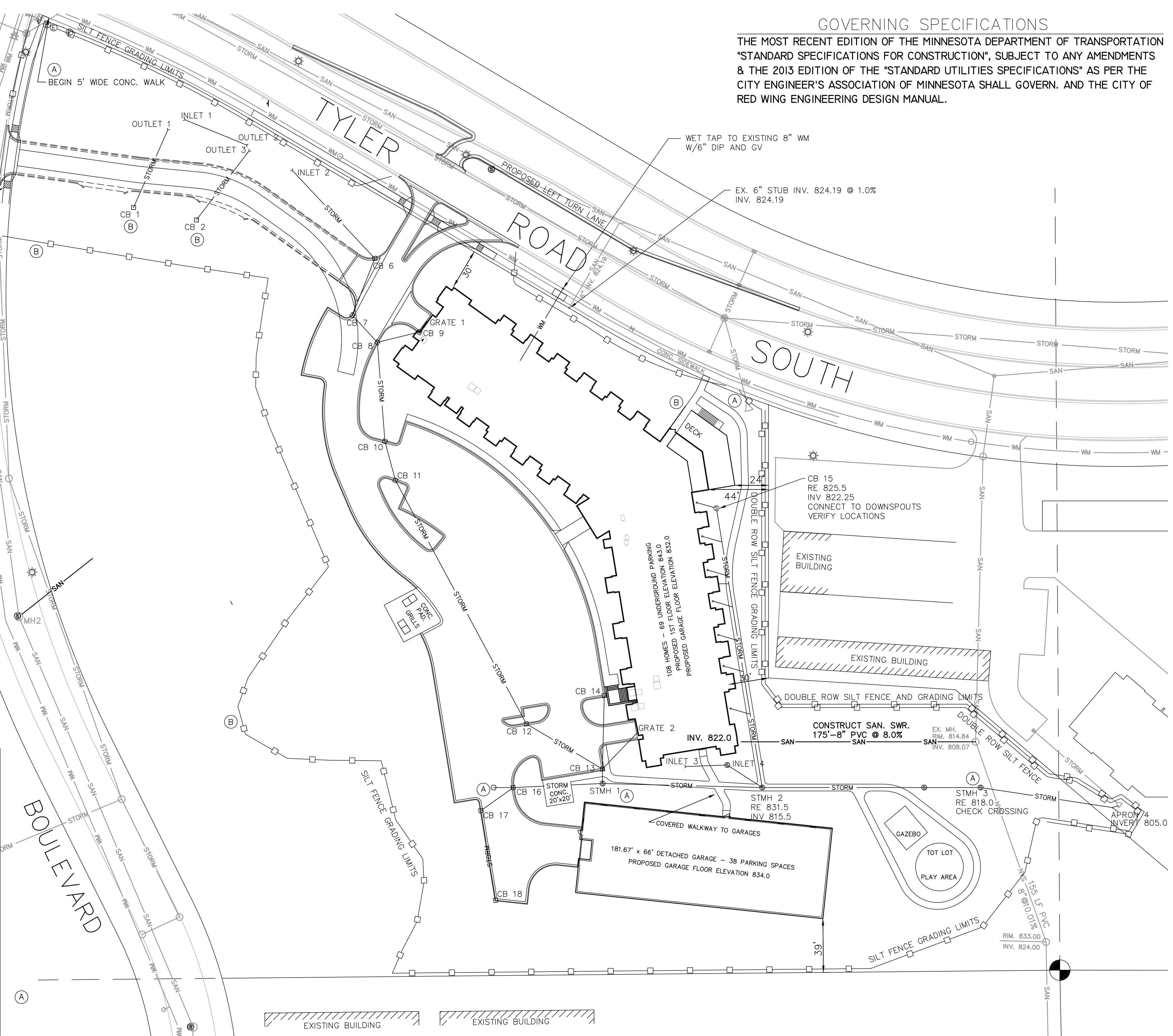

G³ G-Cubed Inc.
 Engineering
 Surveying
 Planning

285 Westview Drive
 West Saint Paul, MN 55118
 ph. 651.288.1100 fax 651.455.4948

I HEREBY CERTIFY THAT THIS PLAN, SPECIFICATION, OR REPORT WAS PREPARED BY ME OR UNDER MY DIRECT SUPERVISION AND I AM A DULY LICENSED PROFESSIONAL ENGINEER UNDER THE LAWS OF THE STATE OF MINNESOTA

Mark Welch
 DATE _____ REG. NO. _____

DESIGNED: DJT
 DRAWN: _____
 CHECKED: _____

REVISED: (A) BY: DJT DATE: 1/9/2019
 (B) BY: DJT DATE: 1/28/2019

LATEST REVISION: 1-28-2019
 Prepared For:
 Andy Baartman
 1489 Hay Creek Valley Rd
 Red Wing, MN 55066

FILE NO.: 07124 Baartman

CITY OF RED WING
 GOODHUE COUNTY, MINNESOTA
 2018 CONSTRUCTION

PARK PLACE
 APARTMENTS

UTILITY
 PLAN

SHEET 5 OF 13 SHEETS

(A) ADDED TEMP BASINS, DITCH BLOCKS, MOVED 3' SUMP TO STMH 1 AND TYLER RD. WORK BY OTHERS, AND REMOVED PHASE 2 SIDEWALK IN HEWITT R/W.
 (B) REMOVED PHASE 2, REVISED RETAINING WALL AND GRADES, TEMP BASIN#1, ADDED CONST. ACCESS RD. AND REVISED ROAD GRADE

CONSTRUCT 3' WIDE CONCRETE VALLEY GUTTER, SEE DETAIL
 CONSTRUCT ONE WAY ENTRANCES 13' WIDE MIN. FACE TO FACE, B612 CONCRETE CURB AND GUTTER
 CONSTRUCT 5' WIDE CONC. SIDEWALK WITH CONC. PED RAMPS, SEE DETAIL
 CONSTRUCT PED. RAMPS 5' BOTTOM, SEE DETAIL
 SAW CUT EXISTING CURB AND GUTTER AND REMOVE
 WORK WITHIN THE TYLER ROAD RIGHT OF WAY - BY CITY, SEE CITY OF RED WING CONSTRUCTION PLANS

Paving Section - TYLER ROAD TURN LANE

CONSTRUCT B618 CONC. CURB AND GUTTER - MATCH EXISTING CURB AND GUTTER
 SIDEWALKS SHALL BE 5' WIDE - SEE DETAILS

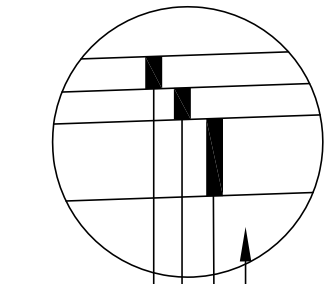

COMPACTED SUBGRADE
 CONST. 8" CL.5 AGG. BASE
 CONST. 1.5" TYPE LVNW BASE COURSE
 LVNW35035B (2360)
 CONST. 1.5" TYPE LV WEAR COURSE
 LVNW35035W (2360)

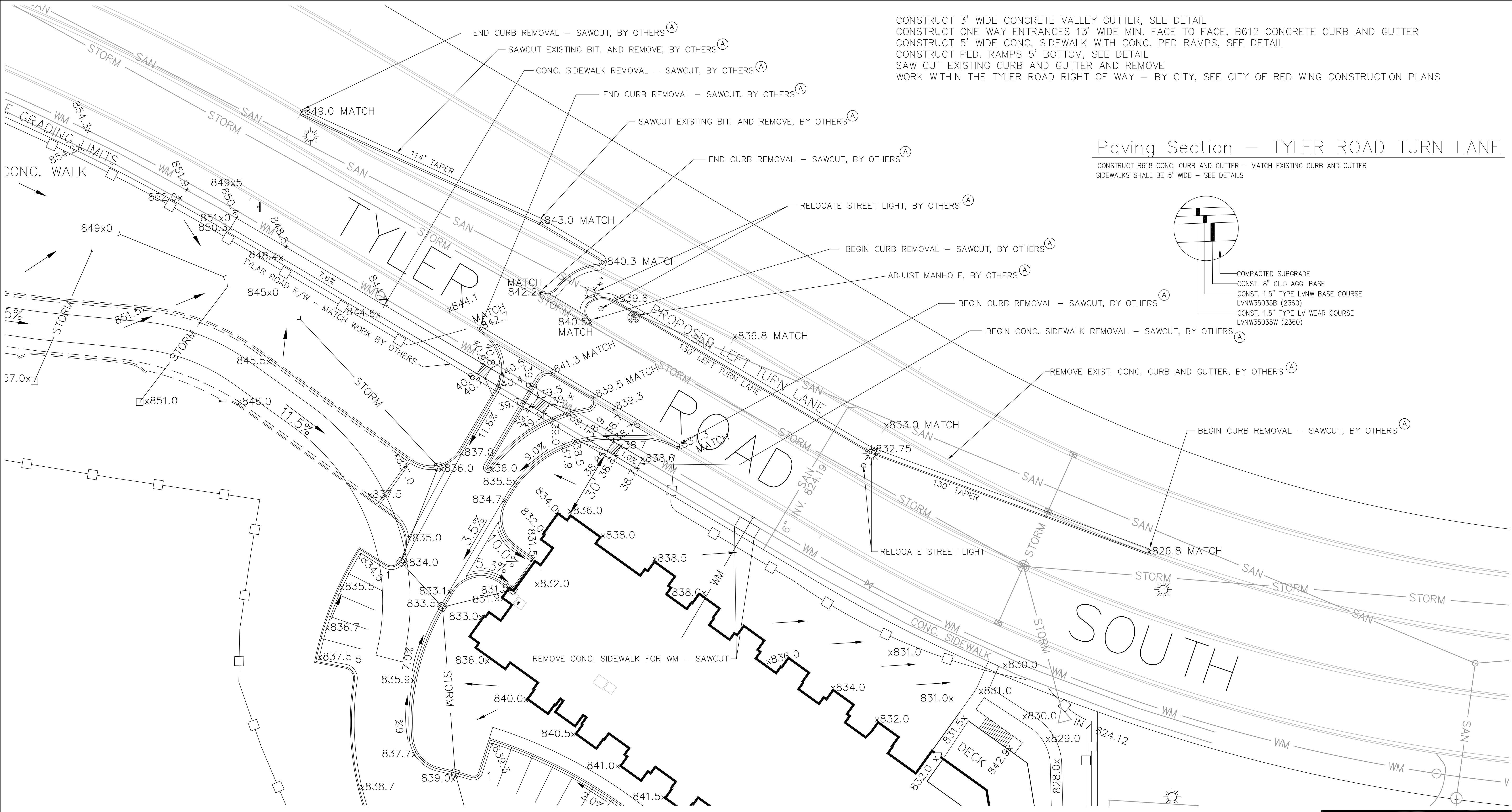

TYLER ROAD DETAIL
 SCALE 1"=20'

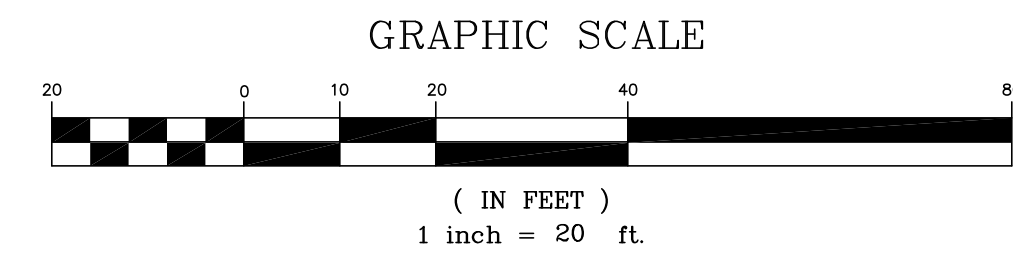

WARNING
 BEFORE DIGGING CALL GOPHER
 STATE ONE CALL FOR LOCATIONS.
 651-454-0002
 REQUIRED BY LAW

G³ G-Cubed Inc.
 Engineering
 Surveying
 Planning
 285 Westview Drive
 West Saint Paul, MN 55118
 ph. 651.288.1100 fax 651.455.4948

I HEREBY CERTIFY THAT THIS PLAN, SPECIFICATION, OR REPORT WAS PREPARED BY ME OR UNDER MY DIRECT SUPERVISION AND I AM A DULY LICENSED PROFESSIONAL ENGINEER UNDER THE LAWS OF THE STATE OF MINNESOTA
 Mark Welch
 DATE _____ REG. NO. _____

DESIGNED	DJT
DRAWN	
CHECKED	

REVISED	BY	DATE	LATEST REVISION: 1-28-2019
(A)	DJT	1/9/2019	Prepared For:
(B)	DJT	1/28/2019	Andy Baartman
			1489 Hay Creek Valley Rd
			Red Wing, MN 55066
			FILE NO.: 07124 Baartman

CITY OF RED WING
 GOODHUE COUNTY, MINNESOTA
 2018 CONSTRUCTION

PARK PLACE
 APARTMENTS

GRADING
 DETAILS
 SHEET 6 OF 13 SHEETS

(A) ADDED TEMP BASINS, DITCH BLOCKS, MOVED 3' SUMP TO STMH 1 AND TYLER RD. WORK BY OTHERS, AND REMOVED PHASE 2 SIDEWALK IN HEWITT R/W.
 (B) REMOVED PHASE 2, REVISED RETAINING WALL AND GRADES, TEMP BASIN#1, ADDED CONST. ACCESS RD. AND REVISED ROAD GRADE

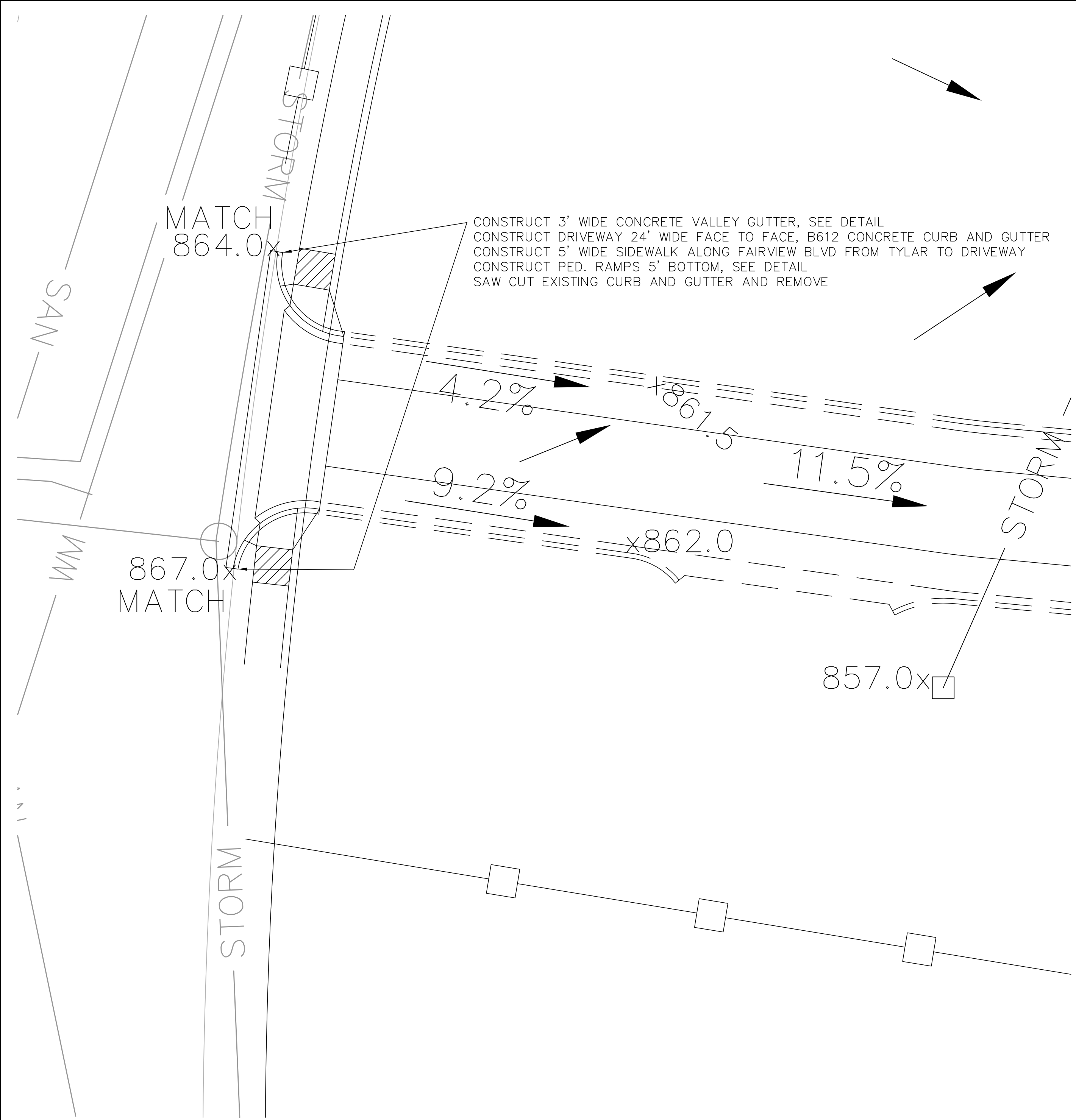

FAIRVIEW BLVD. - NORTH DRIVEWAY DETAIL
 SCALE 1"=10'

WARNING
 BEFORE DIGGING CALL GOPHER
 STATE ONE CALL FOR LOCATIONS.
 651-454-0002
 REQUIRED BY LAW

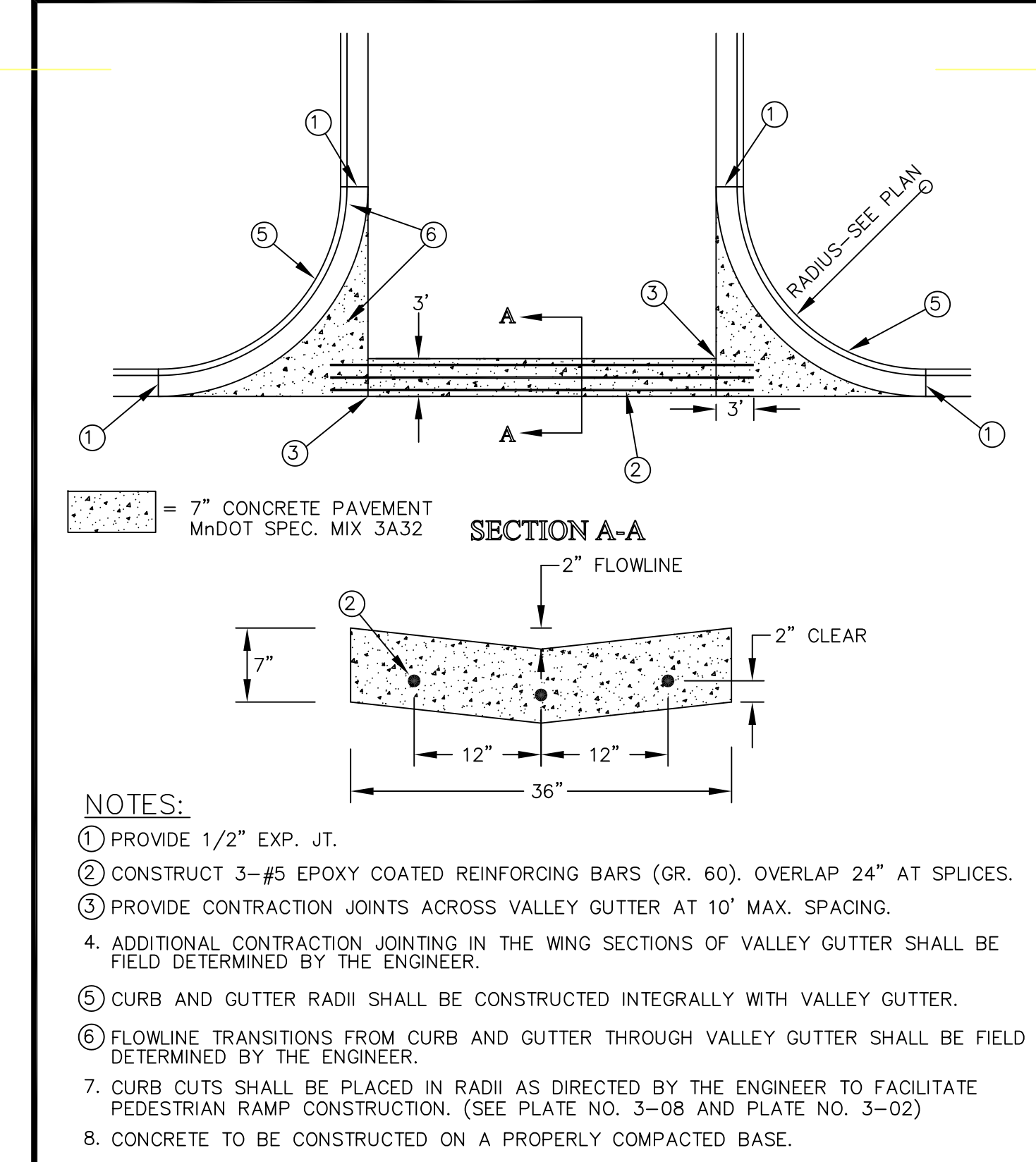
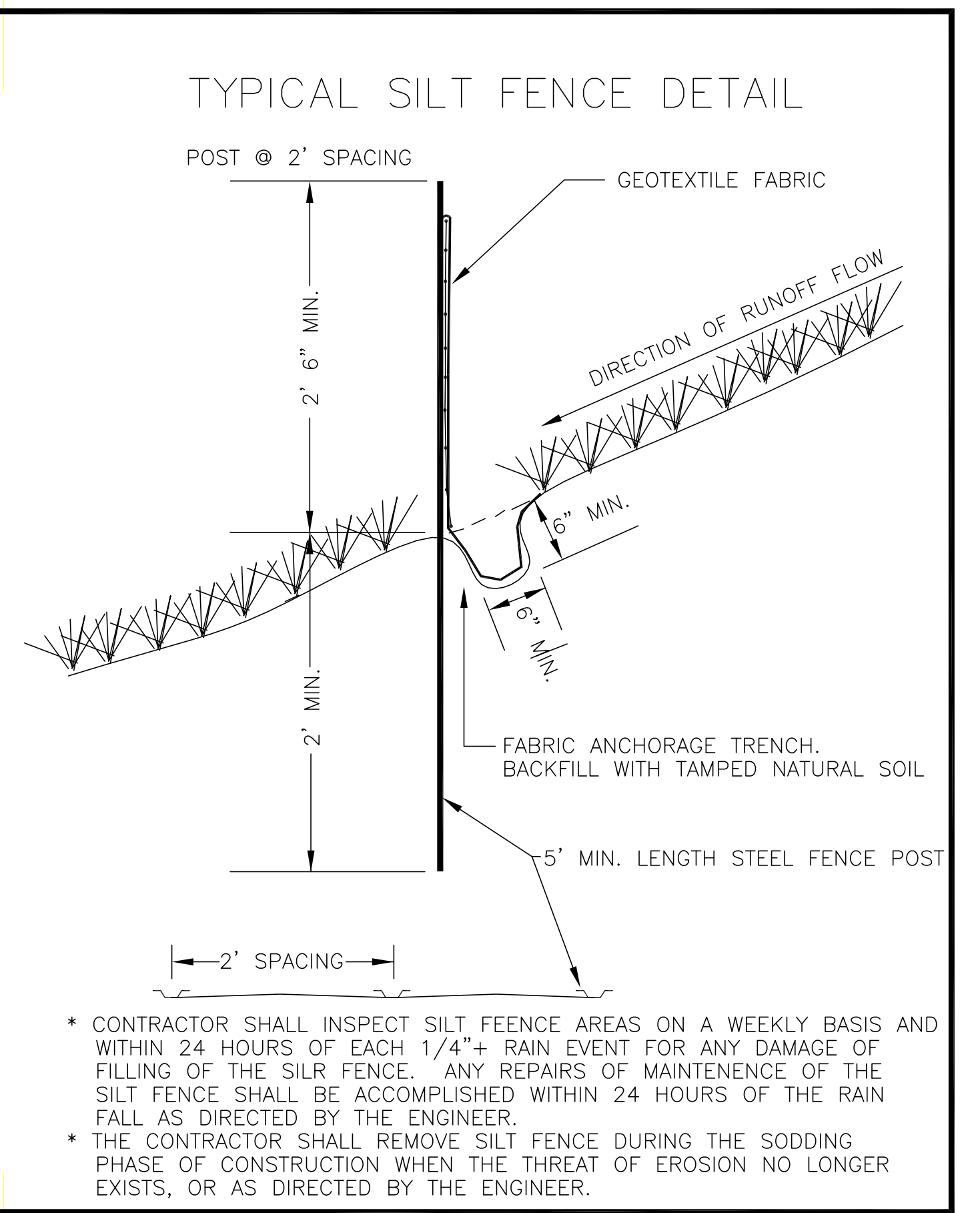
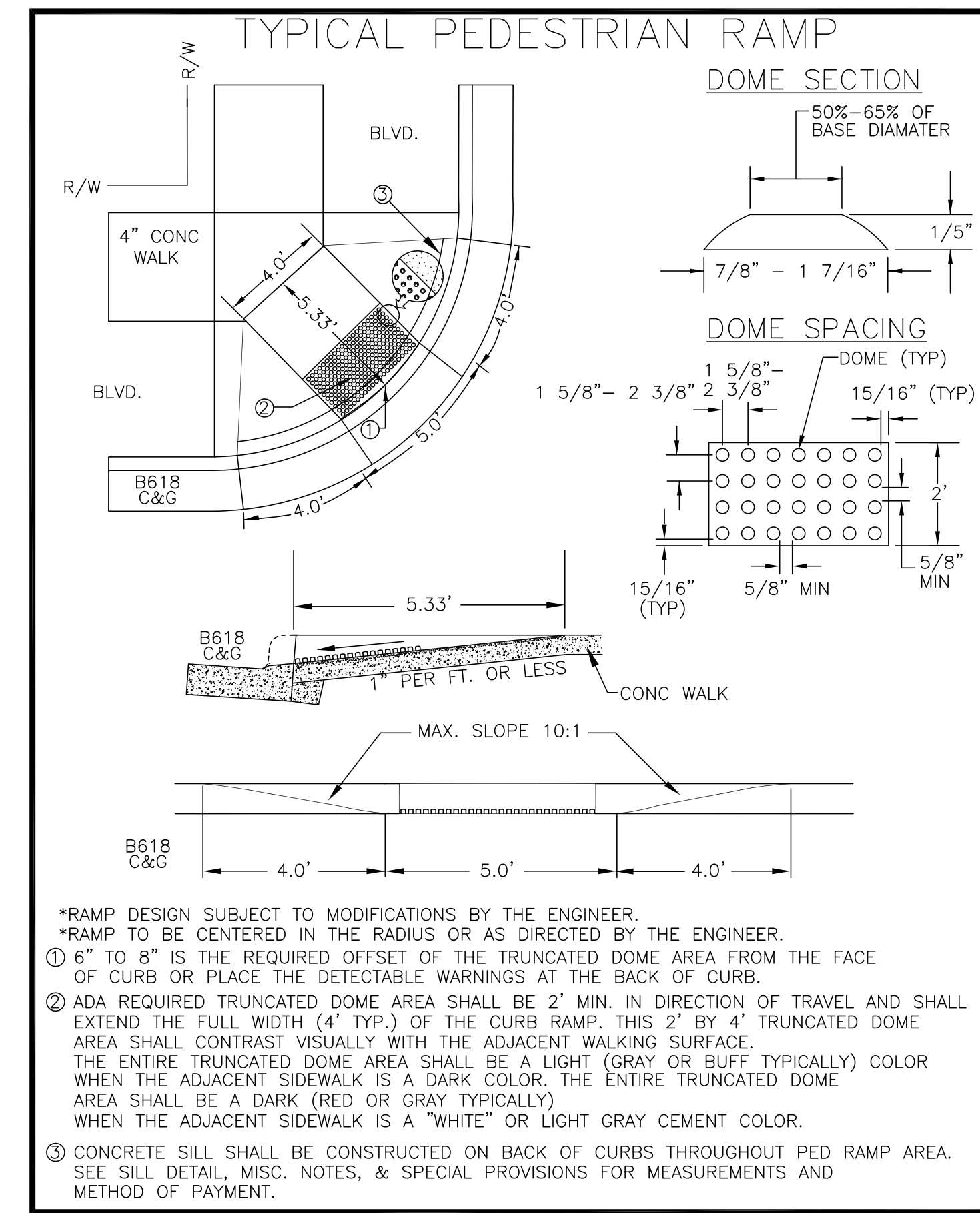

DATE REVISED 03/01/08	CONCRETE VALLEY GUTTER	PLATE NO. 3-07
--------------------------	------------------------	-------------------

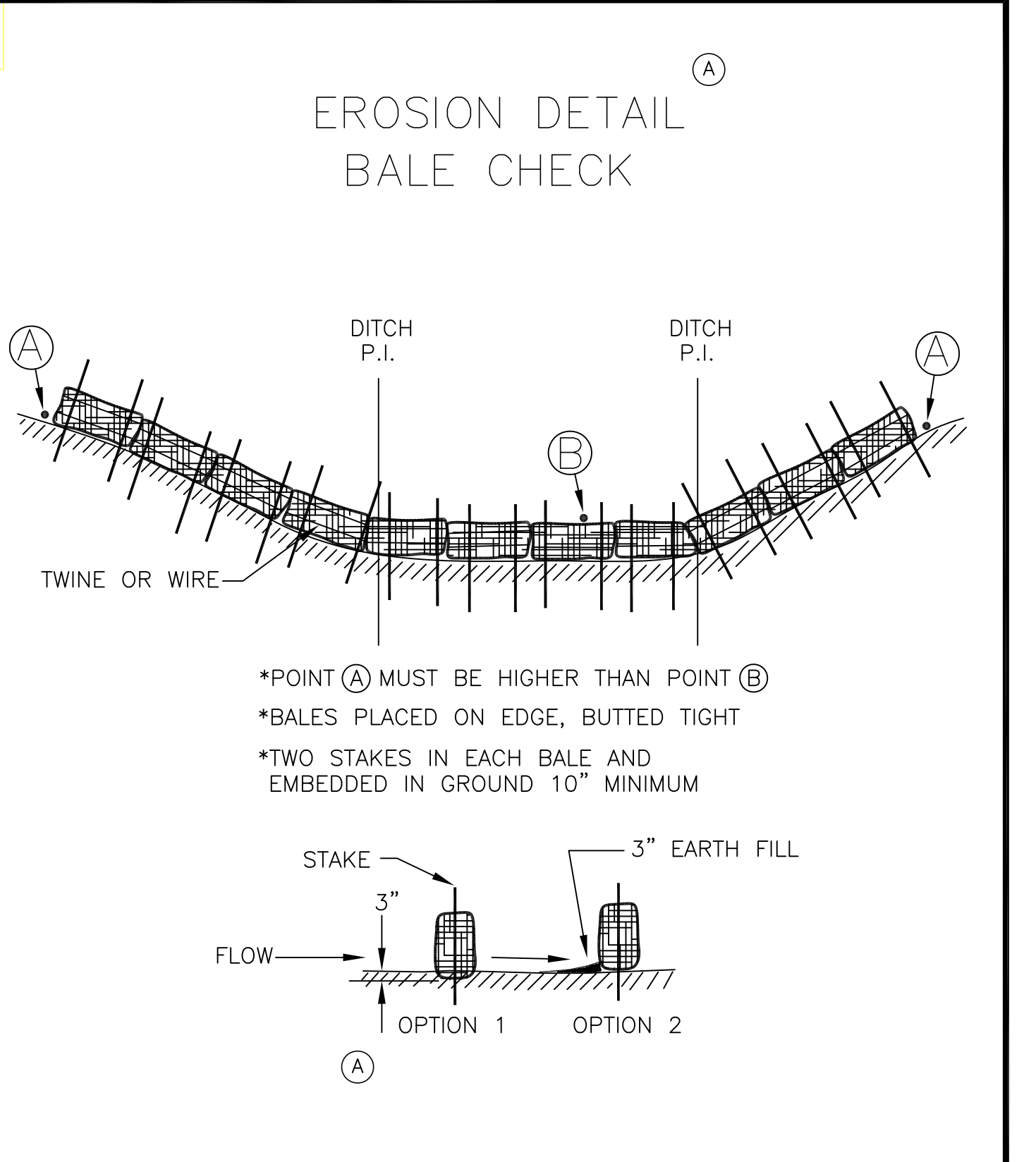

G³ G-Cubed Inc.
 Engineering
 Surveying
 Planning

285 Westview Drive
 West Saint Paul, MN 55118
 ph. 651.288.1100 fax 651.455.4948

Mark Welch
 DATE _____ REG. NO. _____

DESIGNED	DJT	REVISED	BY	DATE	LATEST REVISION: 1-28-2019
DRAWN		(A)	DJT	1/9/2019	Prepared For: Andy Baartman
CHECKED		(B)	DJT	1/28/2019	1489 Hay Creek Valley Rd Red Wing, MN 55066
					FILE NO.: 07124 Baartman

CITY OF RED WING
 GOODHUE COUNTY, MINNESOTA
 2018 CONSTRUCTION

PARK PLACE
 APARTMENTS

GRADING
 DETAILS

SHEET 7 OF 13 SHEETS

(A) ADDED TEMP BASINS, DITCH BLOCKS, MOVED 3' SUMP TO STM 1 AND TYLAR RD. WORK BY OTHERS, AND REMOVED PHASE 2 SIDEWALK IN HEWITT R/W.
 (B) REMOVED PHASE 2, REVISED RETAINING WALL AND GRADES, TEMP BASIN#1, ADDED CONST. ACCESS RD. AND REVISED ROAD GRADE

PLOTTED/REVISED: 4-APR-2018

I/PLOT NAME: s250.l.spn
PATH & FILENAME: OT\S\DesignStandards\Development\New Border\200_Series\s250.l.spn.dgn

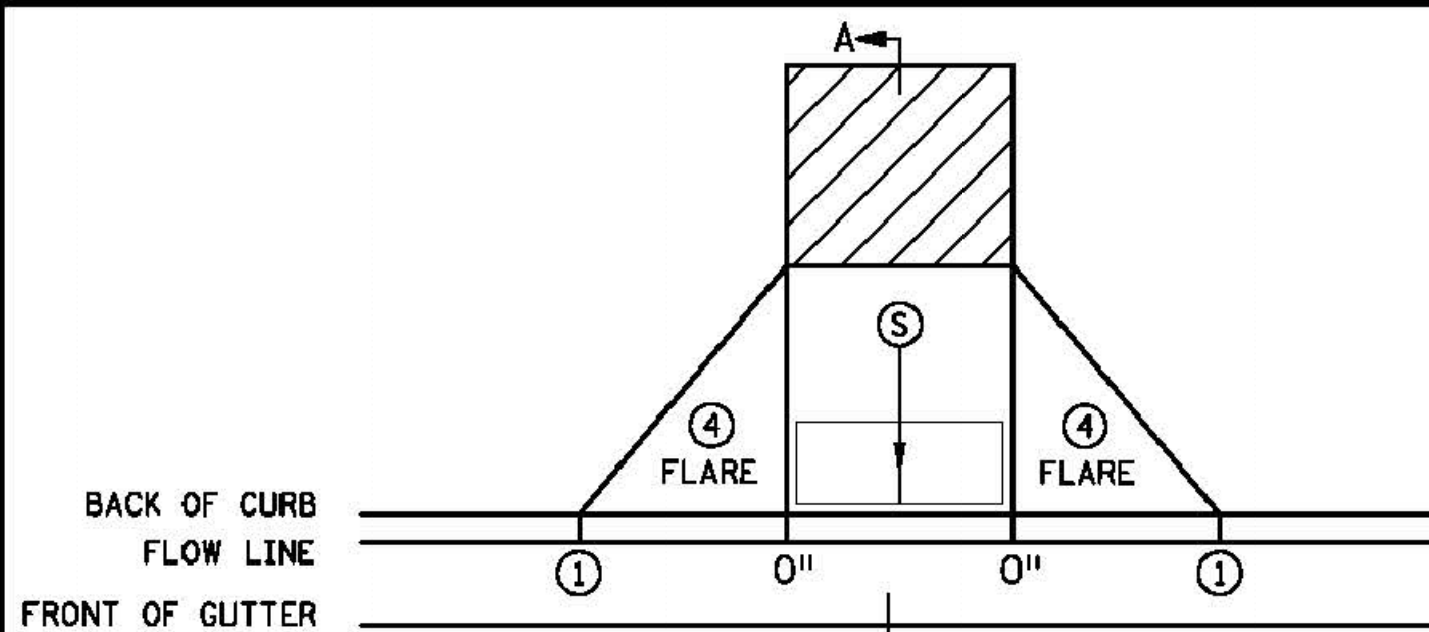

PERPENDICULAR

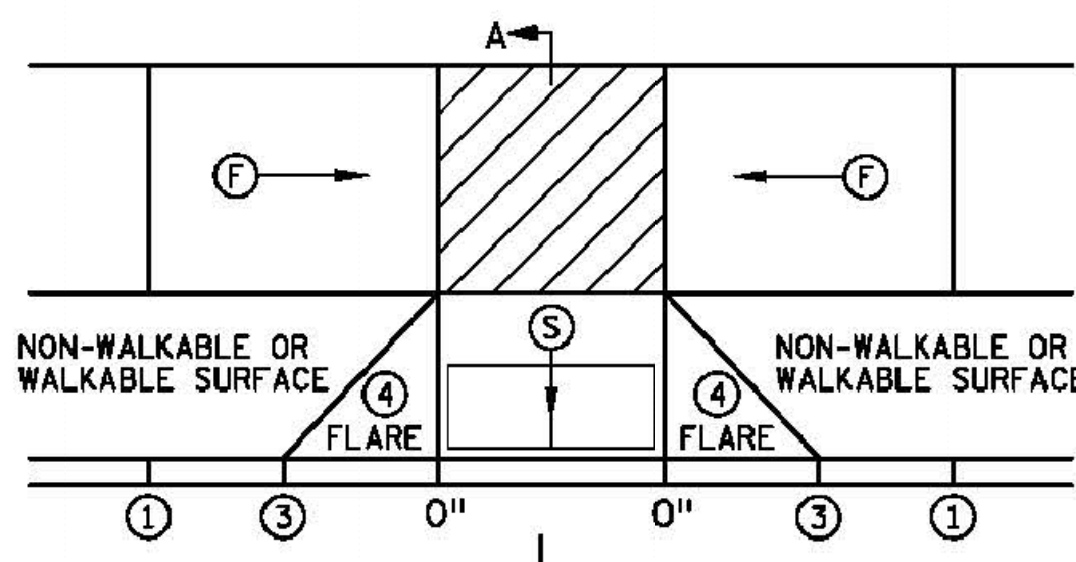

TIERED PERPENDICULAR

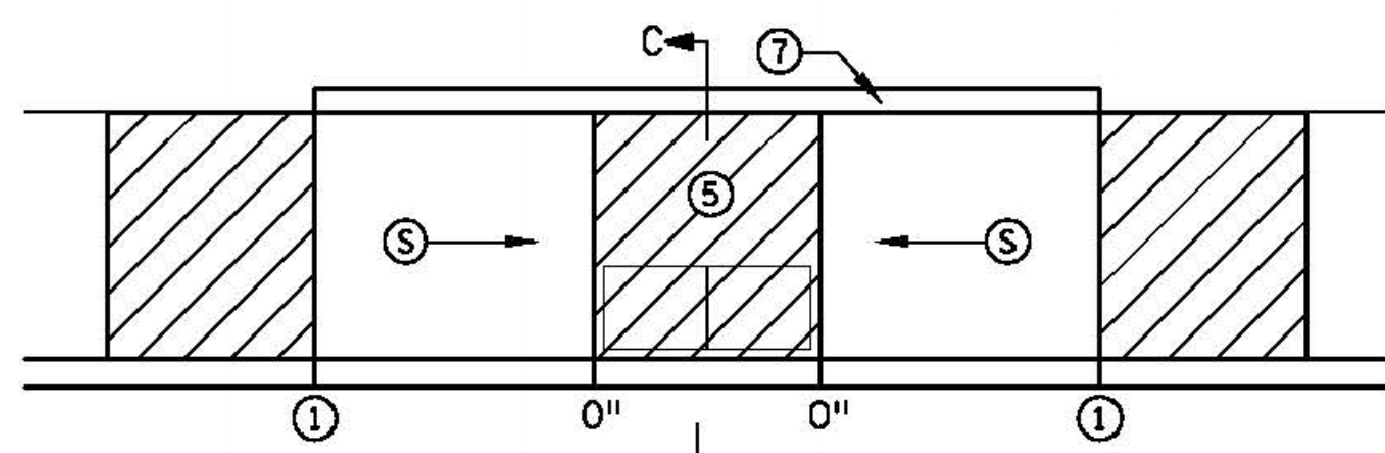

PARALLEL

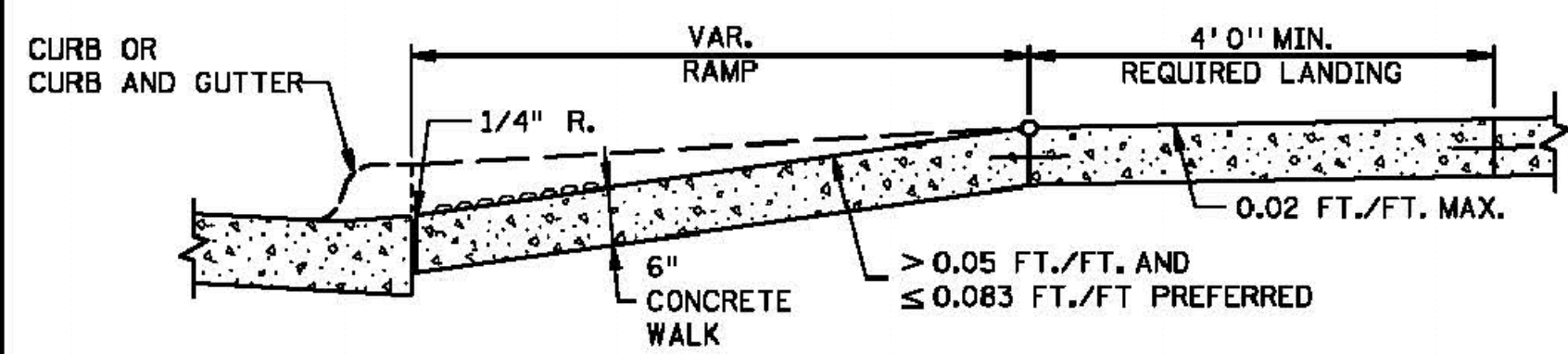

SECTION A-A
PERPENDICULAR/TIERED/DIAGONAL

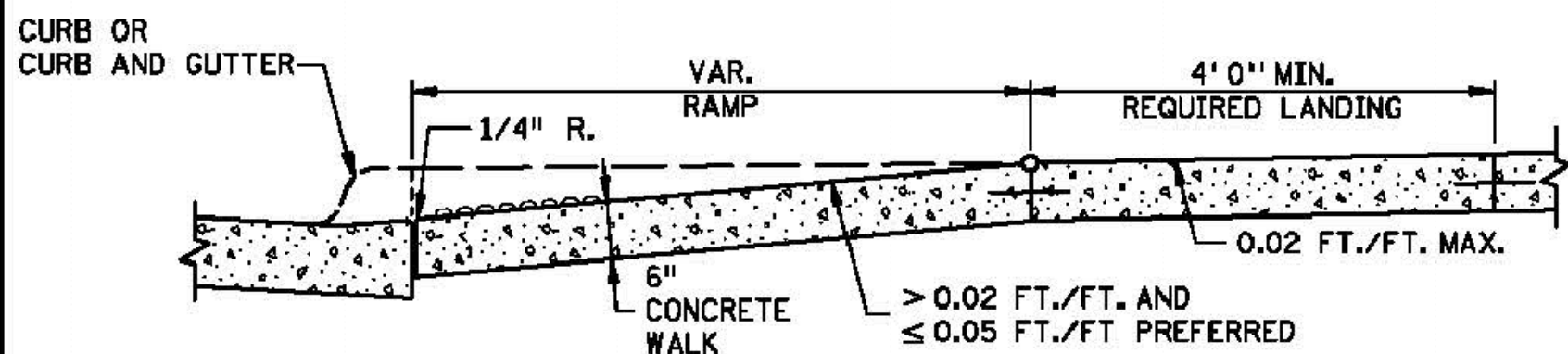

SECTION B-B
FAN

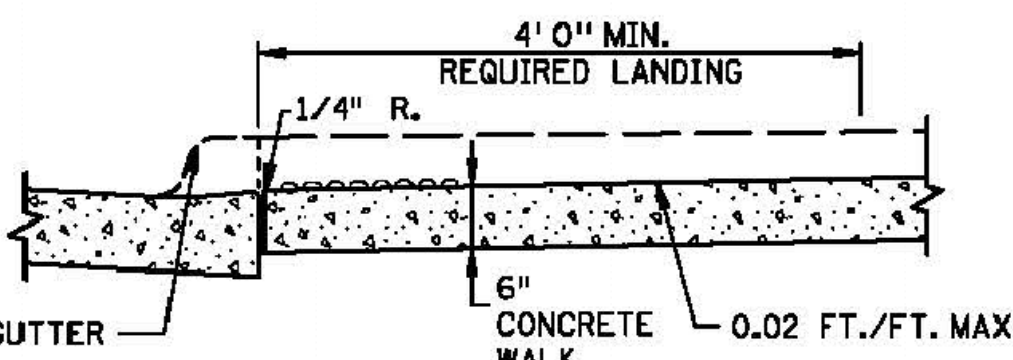

SECTION C-C
PARALLEL/DEPRESSED CORNER

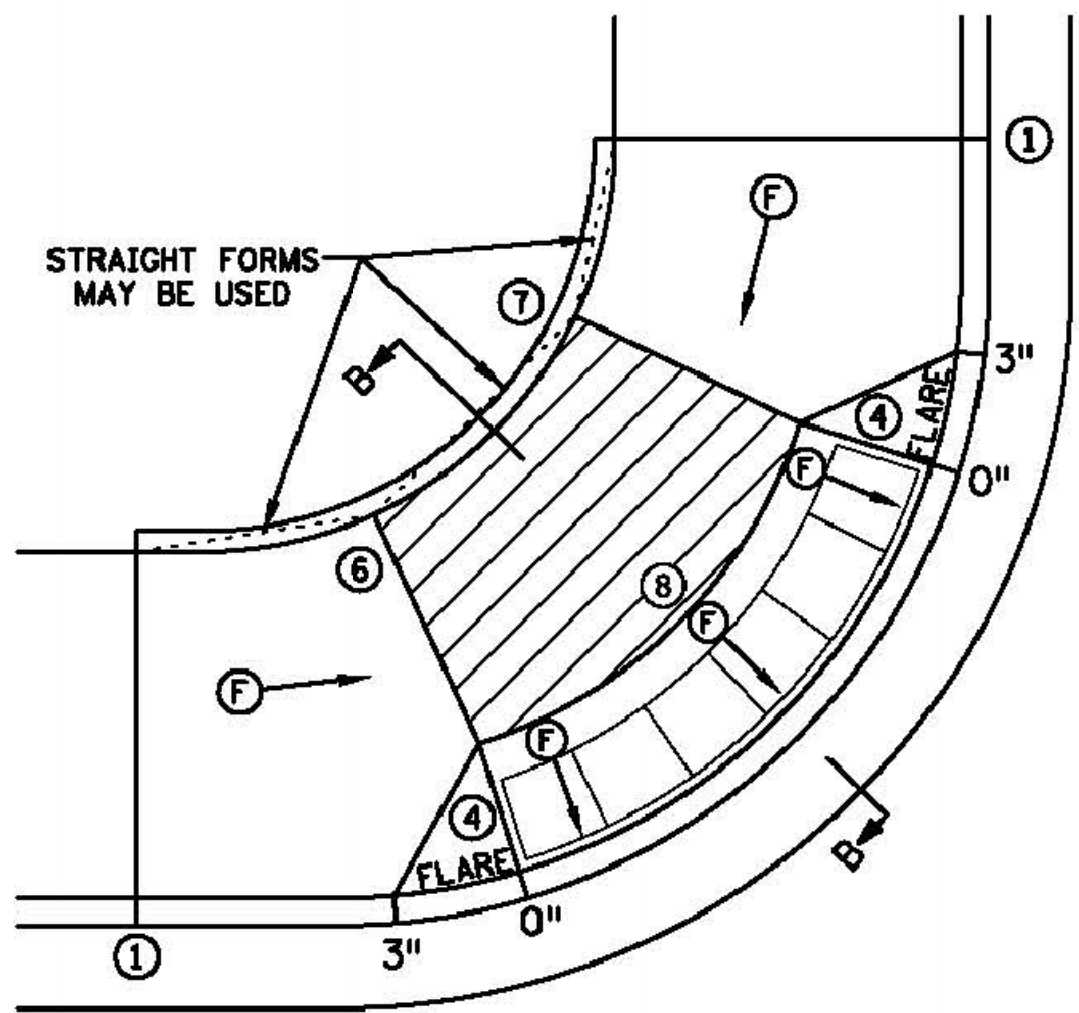

FAN ⑩

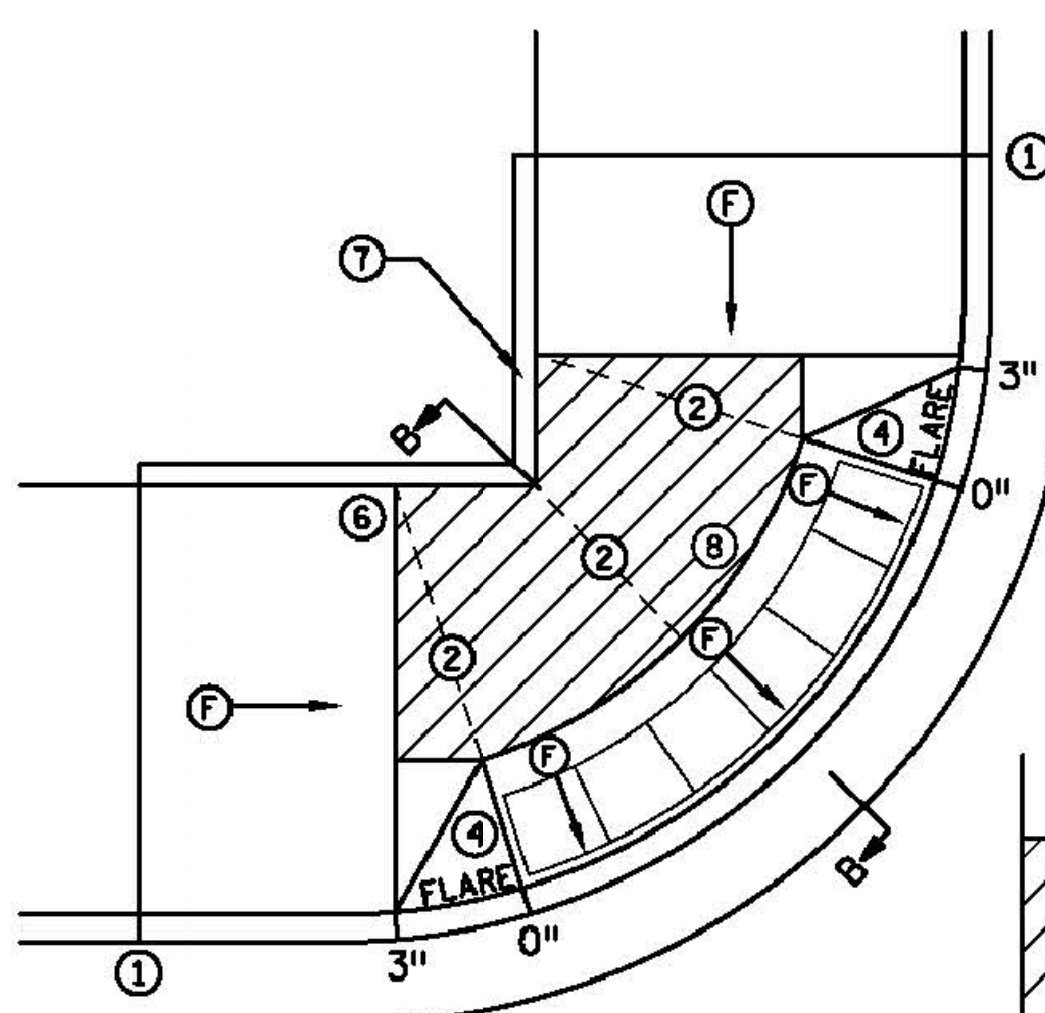

MODIFIED FAN ⑩
USED WHEN RIGHT-OF-WAY IS CONSTRAINED

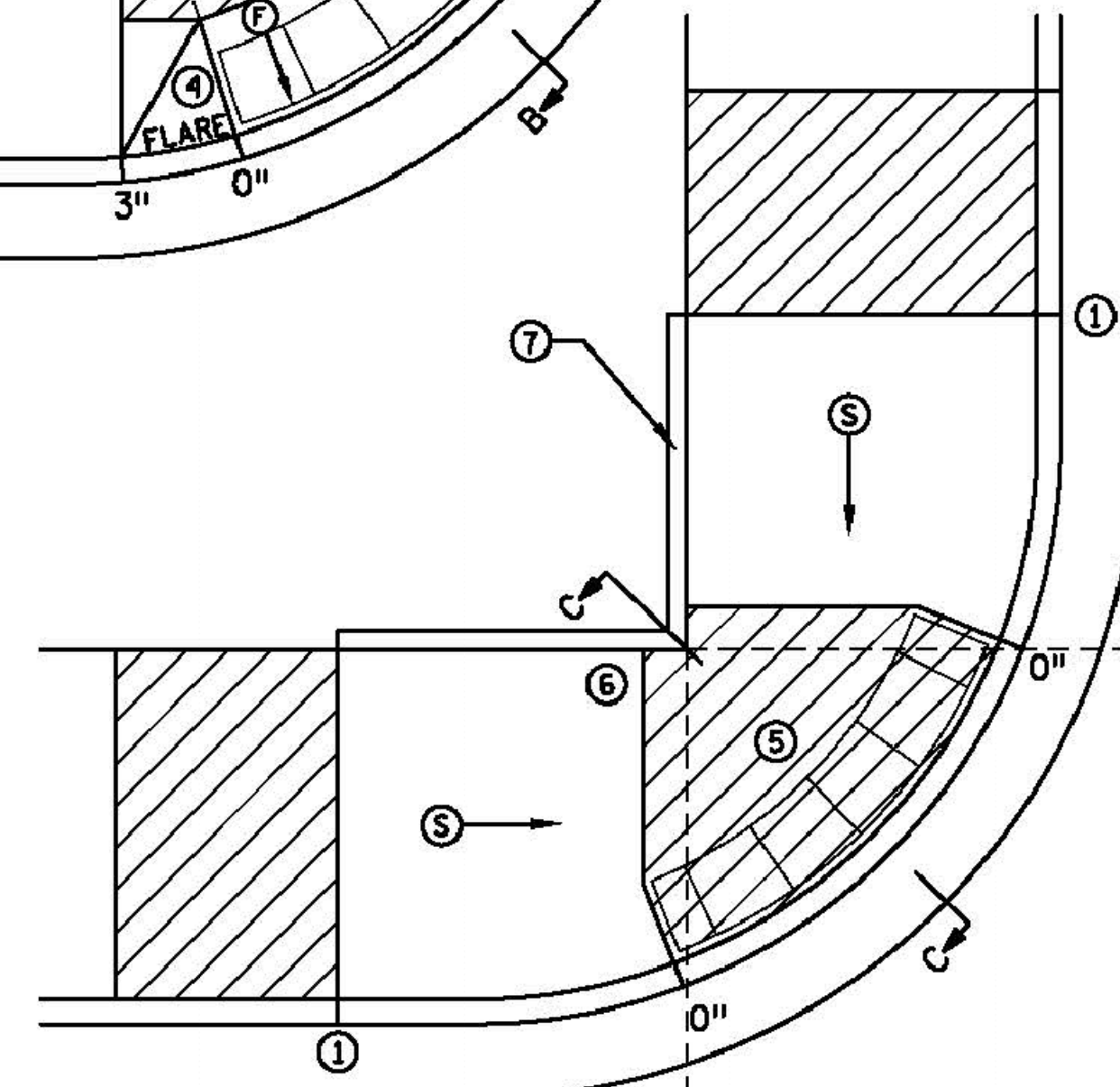

DEPRESSED CORNER

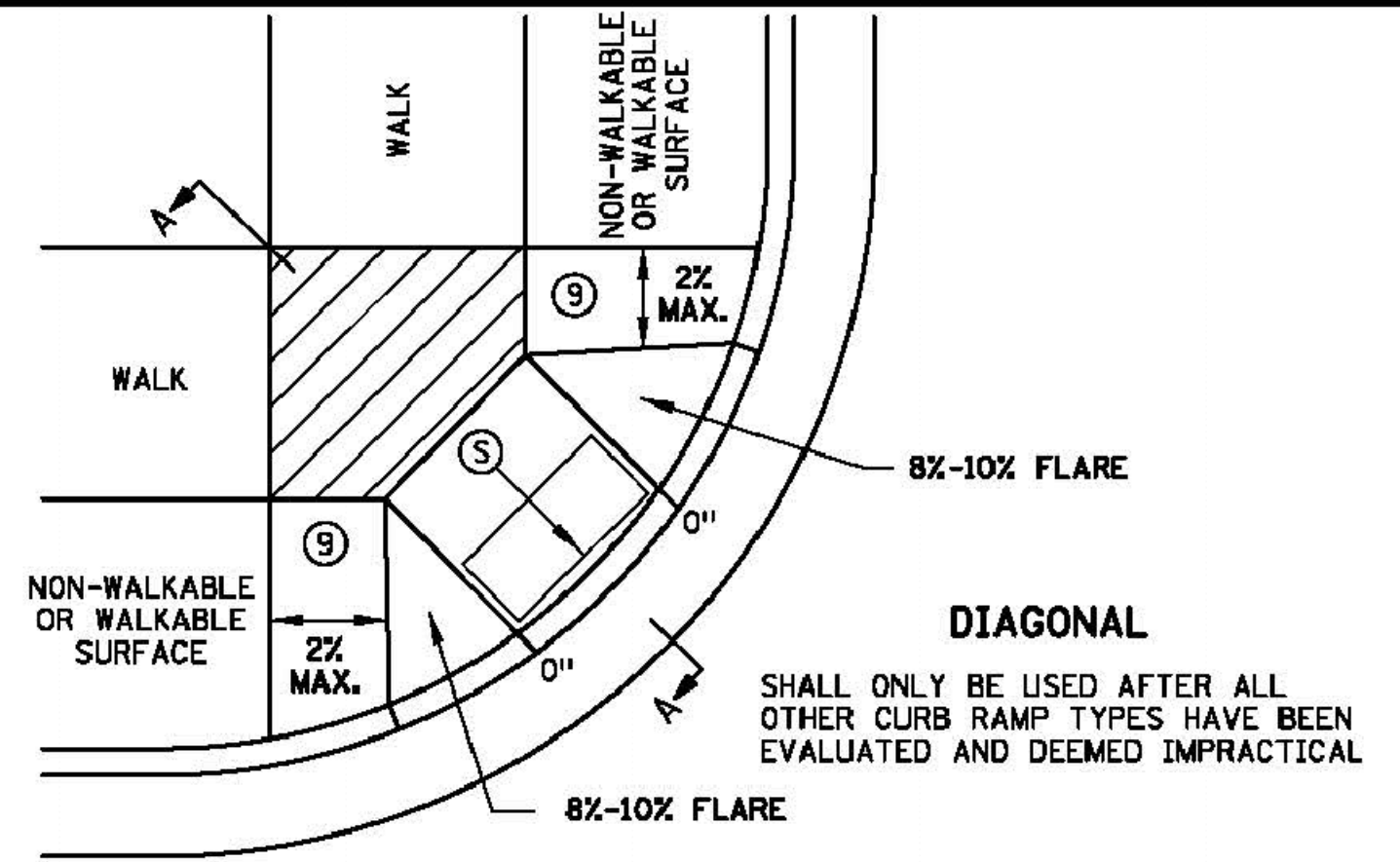

DIAGONAL

NOTES:

- LANDINGS SHALL BE LOCATED ANYWHERE THE PEDESTRIAN ACCESS ROUTE (PAR) CHANGES DIRECTION, AT THE TOP OF RAMPS THAT HAVE RUNNING SLOPES GREATER THAN 5.0%, AND IF THE APPROACHING WALK IS INVERSE GRADE GREATER THAN 2%.
 - INITIAL CURB RAMP LANDINGS SHALL BE CONSTRUCTED WITHIN 15' FROM THE BACK OF CURB, WITH 6' FROM THE BACK OF CURB BEING THE PREFERRED DISTANCE, ONLY APPLICABLE WHEN THE INITIAL RAMP RUNNING SLOPE IS OVER 5.0%.
 - SECONDARY CURB RAMP LANDINGS ARE REQUIRED FOR EVERY 30" OF VERTICAL RISE WHEN THE LONGITUDINAL RUNNING SLOPE IS GREATER THAN 5.0%.
 - CONTRACTION JOINTS SHALL BE CONSTRUCTED ALONG ALL GRADE BREAKS WITHIN THE PAR. 1/4" DEEP VISUAL JOINTS SHALL BE USED AT THE TOPS OF CONCRETE FLARES ADJACENT TO WALKABLE SURFACES.
 - ALL GRADE BREAKS WITHIN THE PAR SHALL BE PERPENDICULAR TO THE PATH OF TRAVEL, THUS BOTH SIDES OF A SLOPED WALKING SURFACE MUST BE EQUAL LENGTH, EXCEPT AS STATED IN ⑥ BELOW.
 - TO ENSURE INITIAL RAMPS AND INITIAL LANDINGS ARE PROPERLY CONSTRUCTED, LANDINGS SHALL BE CAST SEPARATELY, FOLLOW SIDEWALK REINFORCEMENT DETAILS ON SHEET 6 AND THE ADA SPECIAL PROVISIONS - PROSECUTION OF WORK (ADA).
 - TOP OF CURB SHALL MATCH PROPOSED ADJACENT WALK GRADE.
 - WHEN THE BOULEVARD IS 4' WIDE OR LESS, THE TOP OF CURB TAPER SHALL MATCH THE RAMP SLOPES TO REDUCE NEGATIVE BOULEVARD SLOPES FROM THE TOP BACK OF CURB TO THE PAR.
 - ALL RAMP TYPES SHOULD HAVE A MINIMUM 3' LONG RAMP LENGTH.
 - 4' MINIMUM WIDTH OF DETECTABLE WARNING IS REQUIRED FOR ALL RAMPS, DETECTABLE WARNING SHALL CONTINUOUSLY EXTEND FOR A MIN. OF 24" IN THE PATH OF TRAVEL, DETECTABLE WARNING TO COVER ENTIRE WIDTH OF SHARED-USE PATHS AND THE ENTIRE PAR WIDTH OF THE WALK. DETECTABLE WARNING SHOULD BE 6" LESS THAN THE PAR/TRAIL WIDTH, ARC LENGTH OF RADIAL DETECTABLE WARNINGS SHOULD NOT BE GREATER THAN 20 FEET.
 - RECTANGULAR DETECTABLE WARNINGS SHALL BE SETBACK 3" FROM THE BACK OF CURB, RADIAL DETECTABLE WARNINGS SHALL BE SETBACK 3" MINIMUM TO 6" MAXIMUM FROM THE BACK OF CURB.
- MATCH FULL HEIGHT CURB.
 - 4' MINIMUM DEPTH LANDING REQUIRED ACROSS TOP OF RAMP.
 - 3" HIGH CURB WHEN USING A 3' LONG RAMP, 4" HIGH CURB WHEN USING A 4' LONG RAMP.
 - SEE SHEET 4 OF 6, TYPICAL SIDE TREATMENT OPTIONS, FOR DETAILS ON FLARES AND RETURNED CURBS, WHEN INITIAL LANDING IS AT FULL CURB HEIGHT.
 - DETECTABLE WARNINGS MAY BE PART OF THE 4' X 4' MIN. LANDING AREA IF IT IS NOT FEASIBLE TO CONSTRUCT THE LANDING OUTSIDE OF THE DETECTABLE WARNING AREA.
 - THE GRADE BREAK SHALL BE PERPENDICULAR TO THE BACK OF WALK, THIS WILL ENSURE THAT THE GRADE BREAK IS PERPENDICULAR TO THE DIRECTION OF TRAVEL. (TYPICAL FOR ALL)
 - WHEN ADJACENT TO GRASS, GRADING SHALL ALWAYS BE USED WHEN FEASIBLE, V CURB, IF USED, SHALL BE PLACED OUTSIDE THE SIDEWALK LIMITS WHEN RIGHT OF WAY ALLOWS. WHEN ADJACENT TO PARKING LOTS, CONCRETE OR BITUMINOUS TAPERS SHOULD BE USED OVER V CURB TO REDUCE TRIPPING HAZARDS AND FACILITATE SNOW & ICE REMOVAL.
 - A 7' MIN TOP RADIUS GRADE BREAK REQUIRED TO BE CONSTRUCTIBLE.
 - PAVE FULL WALK WIDTH.
 - "S" SLOPES ON FANS SHALL ONLY BE USED WHEN ALL OTHER FEASIBLE OPTIONS HAVE BEEN EVALUATED AND DEEMED IMPRACTICAL.

LEGEND

THESE LONGITUDINAL SLOPE RANGES SHALL BE THE STARTING POINT, IF SITE CONDITIONS WARRANT, LONGITUDINAL SLOPES UP TO 8.3% OR FLATTER ARE ALLOWED.

⑤ INDICATES PEDESTRIAN RAMP - SLOPE SHALL BE BETWEEN 5.0% MINIMUM AND 8.3% MAXIMUM IN THE DIRECTION SHOWN AND THE CROSS SLOPE SHALL NOT EXCEED 2.0%.

⑥ INDICATES PEDESTRIAN RAMP - SLOPE SHALL BE GREATER THAN 2.0% AND LESS THAN 5.0% IN THE DIRECTION SHOWN AND CROSS SLOPE SHALL NOT EXCEED 2.0%.

⑦ LANDING AREA - 4' X 4' MIN. (5' X 5' MIN. PREFERRED) DIMENSIONS AND MAX 2.0% SLOPE IN ALL DIRECTIONS. LANDING SHALL BE FULL WIDTH OF INCOMING PAR.

X" CURB HEIGHT

REVISION:
APPROVED: JANUARY 23, 2017
OPERATIONS ENGINEER

MINNESOTA
DEPARTMENT OF TRANSPORTATION

STANDARD PLAN 5-297.250 1 OF 6

APPROVED: 1-23-2017
REVISOR:

STATE PROJ. NO. (T.H.) SHEET NO. OF SHEETS

PEDESTRIAN CURB RAMP DETAILS

G³ G-Cubed Inc.
Engineering
Surveying
Planning

285 Westview Drive
West Saint Paul, MN 55118
ph. 651.288.1100 fax 651.455.4948

I HEREBY CERTIFY THAT THIS PLAN, SPECIFICATION, OR REPORT WAS PREPARED BY ME OR UNDER MY DIRECT SUPERVISION AND I AM A DULY LICENSED PROFESSIONAL ENGINEER UNDER THE LAWS OF THE STATE OF MINNESOTA.

DATE _____ Mark Welch
REG. NO. _____

DESIGNED	DJT	REVISION	BY	DATE
DRAWN				
CHECKED				

LATEST REVISION: 1-28-2019
Prepared For:
Andy Baartman
1489 Hay Creek Valley Rd
Red Wing, MN 55066
FILE NO.: 07124 Baartman

CITY OF RED WING
GOODHUE COUNTY, MINNESOTA
2018 CONSTRUCTION

PARK PLACE
APARTMENTS

MNDOT STANDARD
DETAILS

PLOTTED/REVISED: 4-APR-2018

IPLOT NAME: s250.2.spr
 PATH & FILENAME: OT\S\DesignStandards\Development\New Border\200_Ser\as250.2.spr.dgn

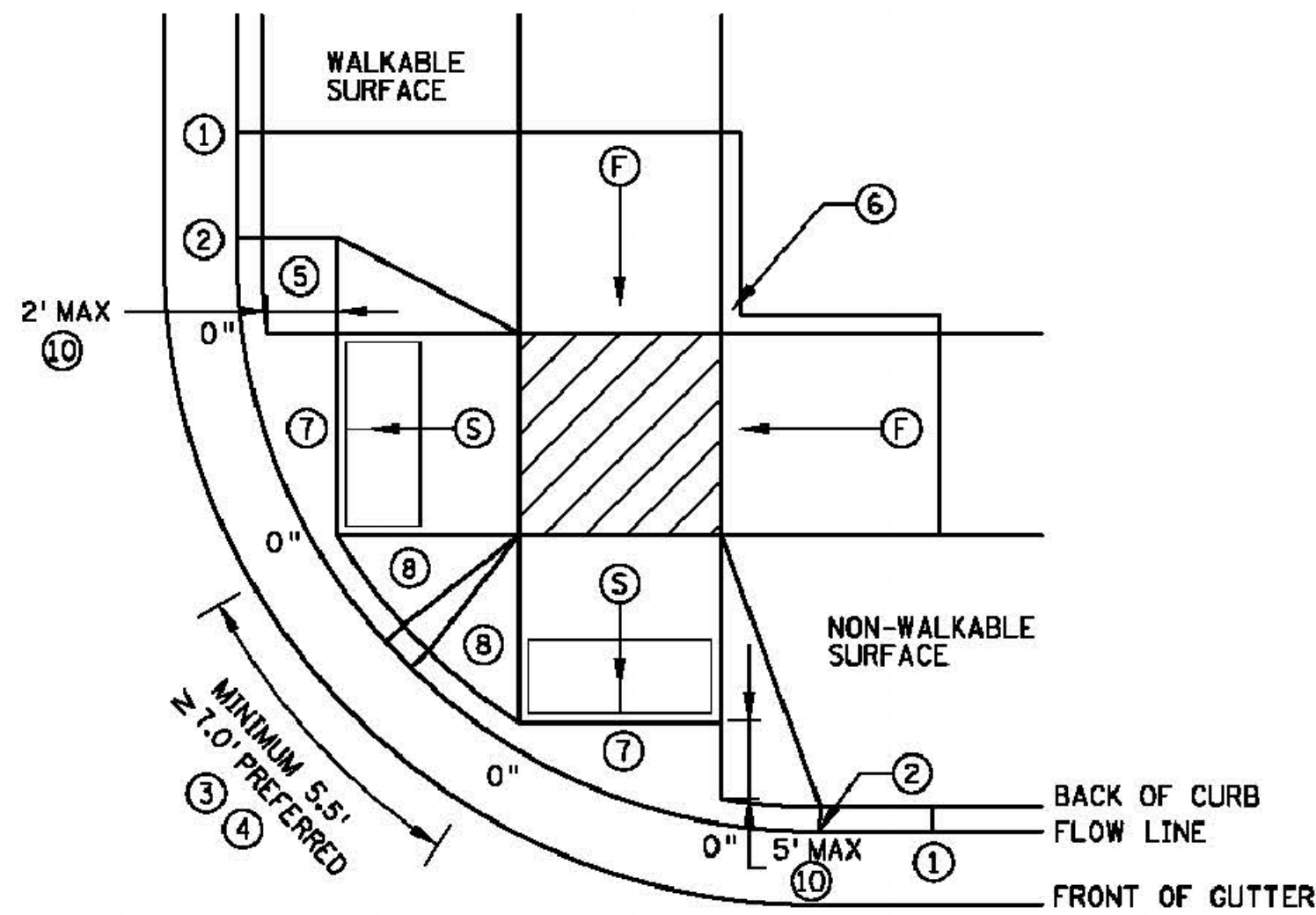

COMBINED DIRECTIONAL ⑨

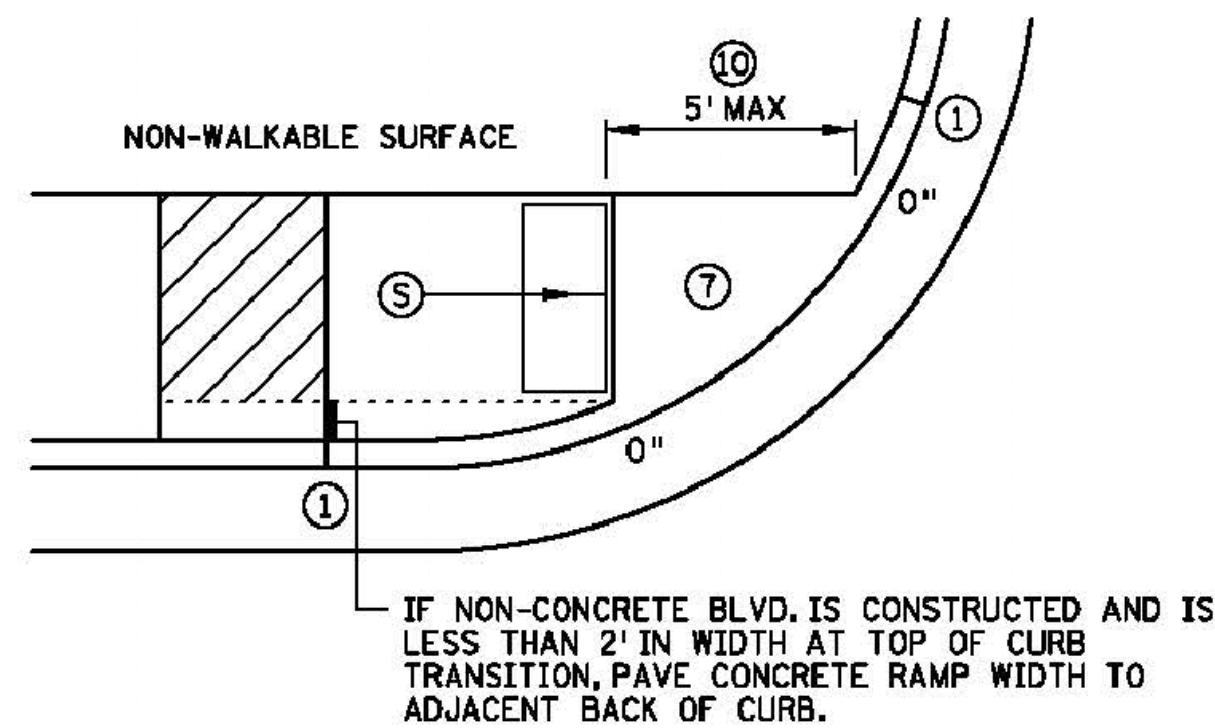

STANDARD ONE-WAY DIRECTIONAL ⑨

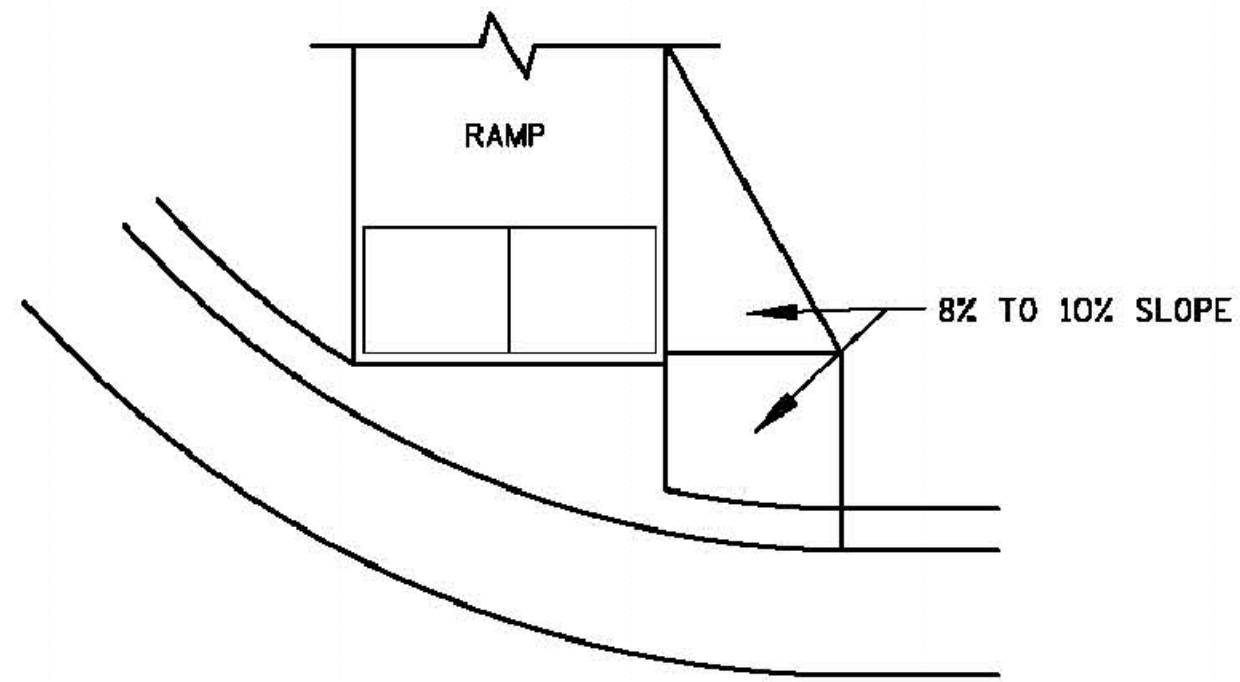

DIRECTIONAL RAMP WALKABLE FLARE

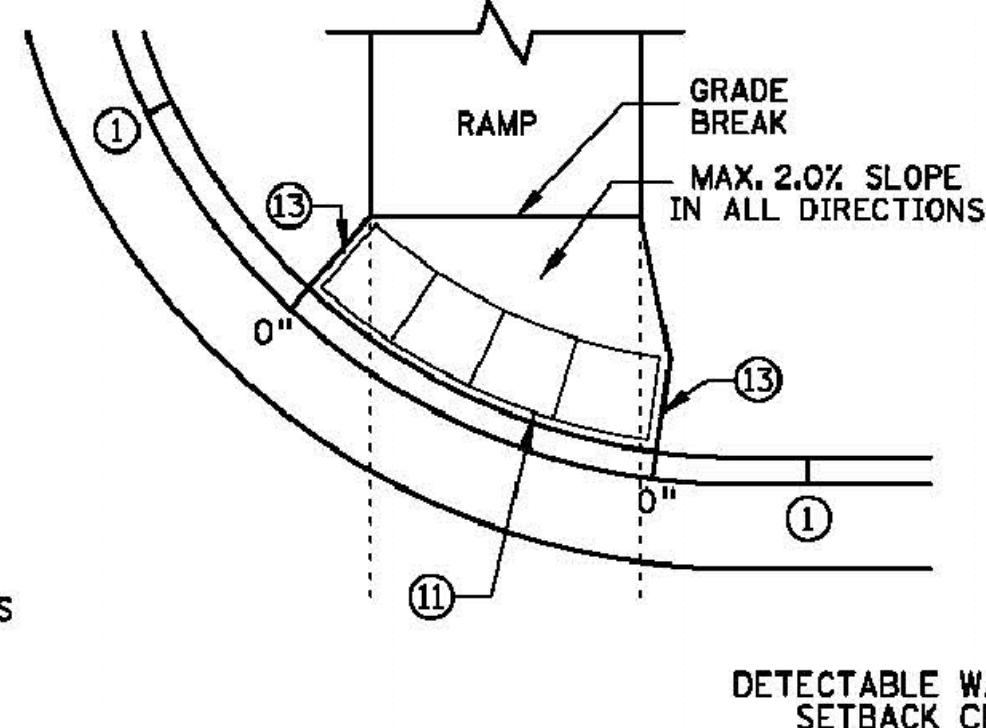

DETECTABLE WARNING PLACEMENT WHEN SETBACK CRITERIA IS EXCEEDED ⑫

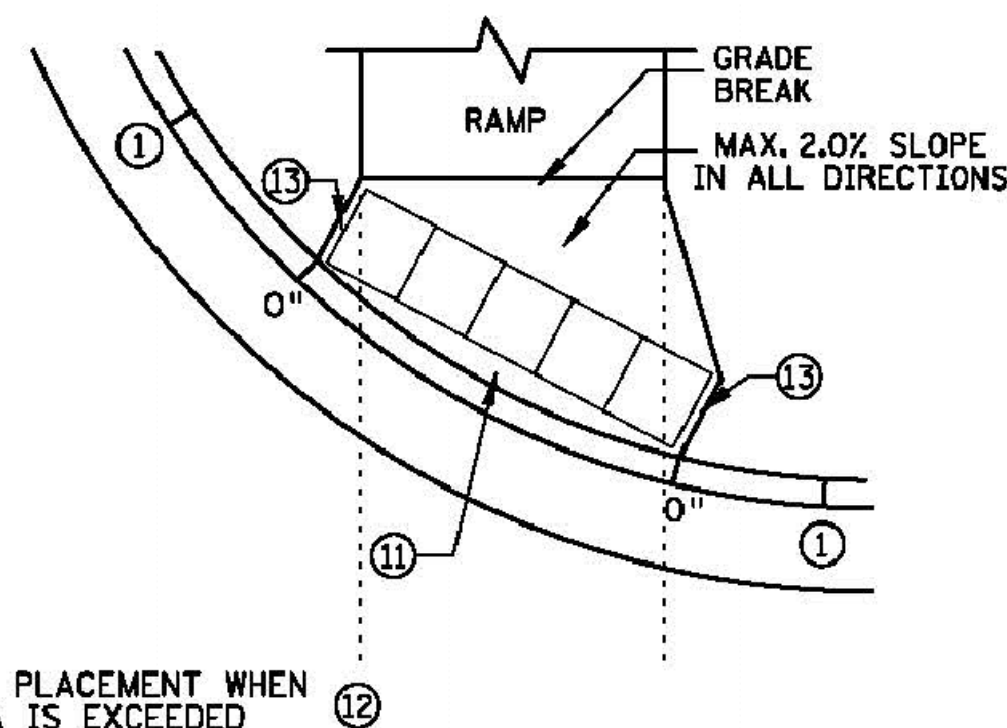

ONE-WAY DIRECTIONAL WITH DETECTABLE WARNING AT BACK OF CURB

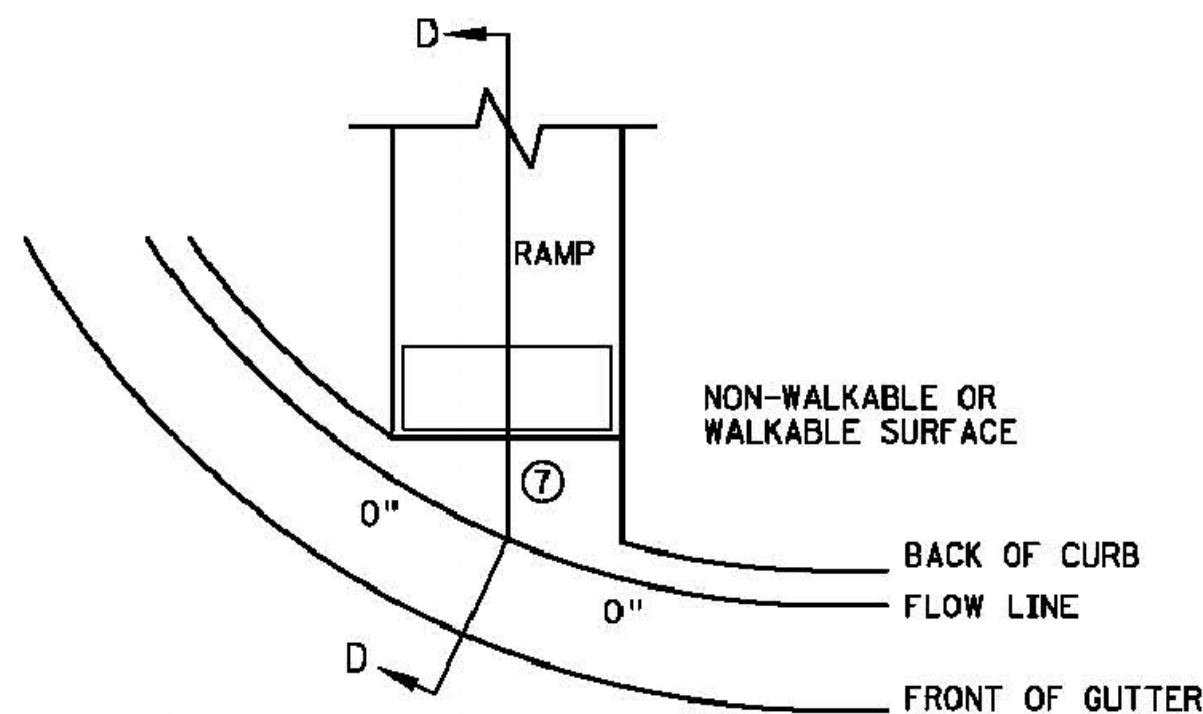

CURB FOR DIRECTIONAL RAMPS ⑭

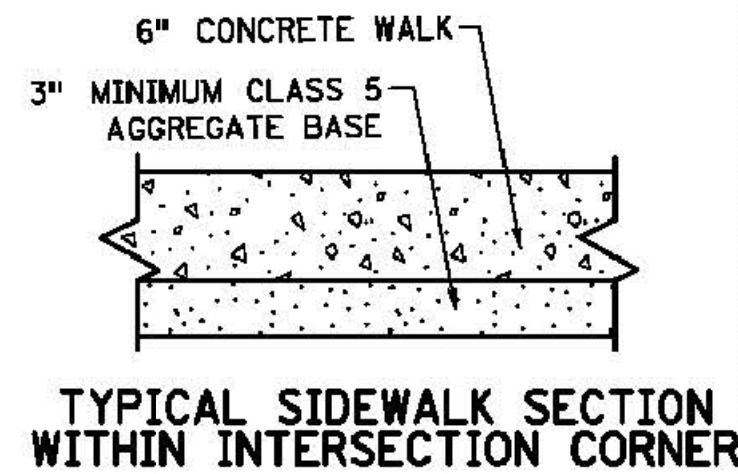
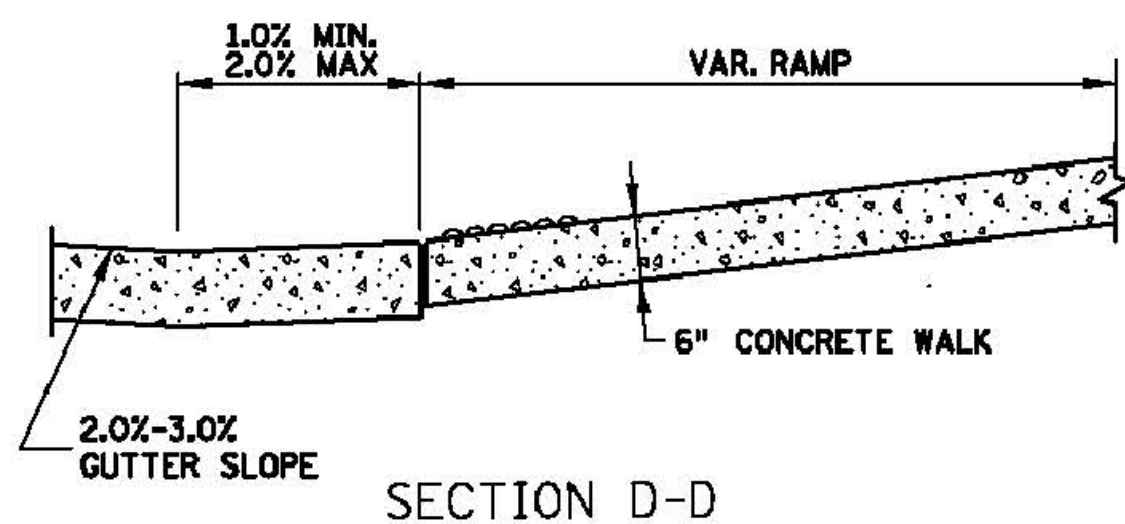

- NOTES:
- LANDINGS SHALL BE LOCATED ANYWHERE THE PEDESTRIAN ACCESS ROUTE (PAR) CHANGES DIRECTION, AT THE TOP OF RAMPS THAT HAVE RUNNING SLOPES GREATER THAN 5.0%, AND IF THE APPROACHING WALK IS INVERSE GRADE.
 - INITIAL CURB RAMP LANDINGS SHALL BE CONSTRUCTED WITHIN 15' FROM THE BACK OF CURB, WITH 6' FROM THE BACK OF CURB BEING THE PREFERRED DISTANCE, ONLY APPLICABLE WHEN THE INITIAL RAMP RUNNING SLOPE IS OVER 5.0%.
 - SECONDARY CURB RAMP LANDINGS ARE REQUIRED FOR EVERY 30" OF VERTICAL RISE WHEN THE LONGITUDINAL SLOPE IS GREATER THAN 5.0%.
 - CONTRACTION JOINTS SHALL BE CONSTRUCTED ALONG ALL GRADE BREAKS WITHIN THE PAR. 1/4" DEEP VISUAL JOINTS SHALL BE USED AT THE TOP GRADE BREAK OF CONCRETE FLARES ADJACENT TO WALKABLE SURFACES.
 - ALL GRADE BREAKS WITHIN THE PAR SHALL BE PERPENDICULAR TO THE PATH OF TRAVEL. THUS BOTH SIDES OF A SLOPED WALKING SURFACE MUST BE EQUAL LENGTH.
 - TO ENSURE INITIAL RAMPS AND INITIAL LANDINGS ARE PROPERLY CONSTRUCTED, LANDINGS SHALL BE CAST SEPARATELY. FOLLOW SIDEWALK REINFORCEMENT DETAILS ON SHEET 6 AND THE ADA SPECIAL PROVISION (PROSECUTION OF WORK).
 - TOP OF CURB SHALL MATCH PROPOSED ADJACENT WALK GRADE.
 - WHEN THE BOULEVARD IS 4' WIDE OR LESS, THE TOP OF CURB TAPER SHALL MATCH THE RAMP SLOPES TO REDUCE NEGATIVE BOULEVARD SLOPES FROM THE TOP BACK OF CURB TO THE PAR.
 - ALL RAMP TYPES SHOULD HAVE A MINIMUM 3' LONG RAMP LENGTH.
 - 4" MINIMUM WIDTH OF DETECTABLE WARNING IS REQUIRED FOR ALL RAMPS. DETECTABLE WARNINGS SHALL CONTINUOUSLY EXTEND FOR A MIN. OF 24" IN THE PATH OF TRAVEL. DETECTABLE WARNING TO COVER ENTIRE WIDTH OF SHARED-USE PATH AND THE ENTIRE PAR WIDTH OF THE WALK. DETECTABLE WARNING SHOULD BE 6" LESS THAN THE PAR/PATH WIDTH. ARC LENGTH OF RADIAL DETECTABLE WARNINGS SHOULD NOT BE GREATER THAN 20 FEET.
 - RADIAL DETECTABLE WARNINGS SHALL BE SETBACK 3" MINIMUM TO 6" MAXIMUM FROM THE BACK OF CURB. SEE NOTES ⑩ & ⑪ FOR INFORMATION REGARDING RECTANGULAR DETECTABLE WARNING PLACEMENT.
- ① MATCH FULL CURB HEIGHT.
 - ② 3" HIGH CURB WHEN USING A 3' LONG RAMP
4" HIGH CURB WHEN USING A 4' LONG RAMP.
 - ③ 3" MINIMUM CURB HEIGHT (5.5' MIN. DISTANCE REQUIRED BETWEEN DOMES)
4" PREFERRED (7' MIN. DISTANCE REQUIRED BETWEEN DOMES).
 - ④ THE "BUMP" IN BETWEEN THE RAMPS SHOULD NOT BE IN THE PATH OF TRAVEL FOR COMBINED DIRECTIONAL RAMPS. IF THIS OCCURS MODIFY THE RAMP LOCATION OR SWITCH RAMP TO A FAN/DEPRESSED CORNER.
 - ⑤ WHEN USING CONCRETE PAVED FLARES ON THE OUTSIDE OF DIRECTIONAL RAMPS, AND ADJACENT TO A WALKABLE SURFACE, DIRECTIONAL RAMP FLARES SHOULD BE USED. SEE THE DETAIL ON THIS SHEET.
 - ⑥ GRADING SHALL ALWAYS BE USED WHEN FEASIBLE. V CURB, IF USED, SHALL BE PLACED OUTSIDE THE SIDEWALK LIMITS WHEN RIGHT OF WAY ALLOWS. WHEN ADJACENT TO PARKING LOTS, CONCRETE OR BITUMINOUS TAPERS SHOULD BE USED OVER V CURB TO REDUCE TRIPPING HAZARDS AND FACILITATE SNOW & ICE REMOVAL.
 - ⑦ MAX. 2.0% SLOPE IN ALL DIRECTIONS IN FRONT OF GRADE BREAK AND DRAIN TO FLOW LINE. SHALL BE CONSTRUCTED INTEGRAL WITH CURB AND GUTTER.
 - ⑧ 8% TO 10% WALKABLE FLARE.
 - ⑨ PLACE DOMES AT THE BACK OF CURB WHEN ALLOWABLE SETBACK CRITERIA IS EXCEEDED.
 - ⑩ FRONT EDGE OF DETECTABLE WARNING SHALL BE SET BACK 2' MAXIMUM WHEN ADJACENT TO WALKABLE SURFACE, AND 5' MAXIMUM WHEN ADJACENT TO NON-WALKABLE SURFACE WITH ONE CORNER SET 3" FROM BACK OF CURB. A WALKABLE SURFACE IS DEFINED AS A PAVED SURFACE ADJACENT TO A CURB RAMP WITHOUT RAISED OBSTACLES THAT COULD MISTAKENLY BE TRAVERSED BY A USER WHO IS VISUALLY IMPAIRED.
 - ⑪ RECTANGULAR DETECTABLE WARNINGS MAY BE SETBACK UP TO 9" FROM THE BACK OF CURB WITH CORNERS SET 3" FROM BACK OF CURB. IF 9" SETBACK IS EXCEEDED USE RADIAL DETECTABLE WARNINGS.
 - ⑫ FOR DIRECTIONAL RAMPS WITH THE DETECTABLE WARNINGS PLACED AT THE BACK OF CURB, THE DETECTABLE WARNINGS SHALL COVER THE ENTIRE WIDTH OF THE WALK/PATH. THIS ENSURES A DETECTABLE EDGE AND HELPS ELIMINATE THE CURB TAPER OBSTRUCTING THE PATH OF PEDESTRIAN TRAVEL.
 - ⑬ THE CONCRETE WALK SHALL BE FORMED AND CONSTRUCTED PERPENDICULAR TO THE BACK OF CURB. MAINTAIN 3" BETWEEN EDGE OF DOMES AND EDGE OF CONCRETE.
 - ⑭ TO BE USED FOR ALL DIRECTIONAL RAMPS, EXCEPT WHERE DOMES ARE PLACED ALONG THE BACK OF CURB.

LEGEND	
THESE LONGITUDINAL SLOPE RANGES SHALL BE THE STARTING POINT. IF SITE CONDITIONS WARRANT, LONGITUDINAL SLOPES UP TO 8.3% OR FLATTER ARE ALLOWED.	
⑤	INDICATES PEDESTRIAN RAMP - SLOPE SHALL BE BETWEEN 5.0% MINIMUM AND 8.3% MAXIMUM IN THE DIRECTION SHOWN AND THE CROSS SLOPE SHALL NOT EXCEED 2.0%.
⑥	INDICATES PEDESTRIAN RAMP - SLOPE SHALL BE GREATER THAN 2.0% AND LESS THAN 5.0% IN THE DIRECTION SHOWN AND CROSS SLOPE SHALL NOT EXCEED 2.0%.
	LANDING AREA - 4' X 4' MIN. (5' X 5' MIN. PREFERRED) DIMENSIONS AND MAX 2.0% SLOPE IN ALL DIRECTIONS. LANDING SHALL BE FULL WIDTH OF INCOMING PAR.
X"	CURB HEIGHT

REVISIONS
APPROVED: JANUARY 23, 2017
OPERATIONS ENGINEER

	STANDARD PLAN 5-297.250	2 OF 6	PEDESTRIAN CURB RAMP DETAILS		
	 STATE DESIGN ENGINEER	APPROVED: 1-23-2017 REVISED:			

DESIGNED	DRAWN	CHECKED	REVISION	BY	DATE
DJT					

LATEST REVISION: 1-28-2019
 Prepared For: Andy Baartman
 1489 Hay Creek Valley Rd
 Red Wing, MN 55066
 FILE NO.: 07124 Baartman

PLOTTED/REVISED: 4-APR-2018

PLOT NAME: s250_3.spl
PATH & FILENAME: OTS\DesignStandards\Development\New Border\200_Series\250_3.spl.dgn

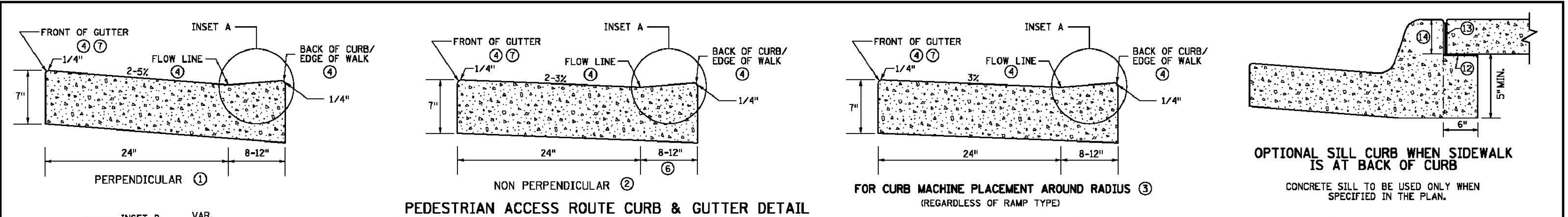

OPTIONAL SILL CURB WHEN SIDEWALK IS AT BACK OF CURB
CONCRETE SILL TO BE USED ONLY WHEN SPECIFIED IN THE PLAN.

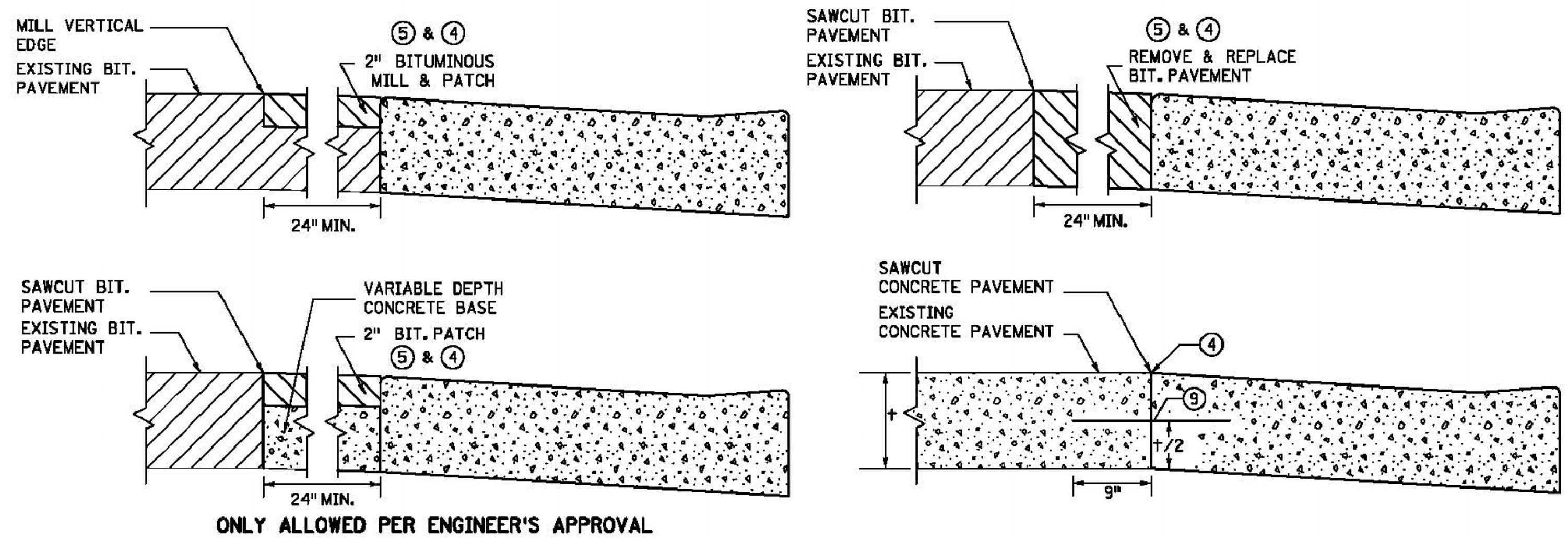
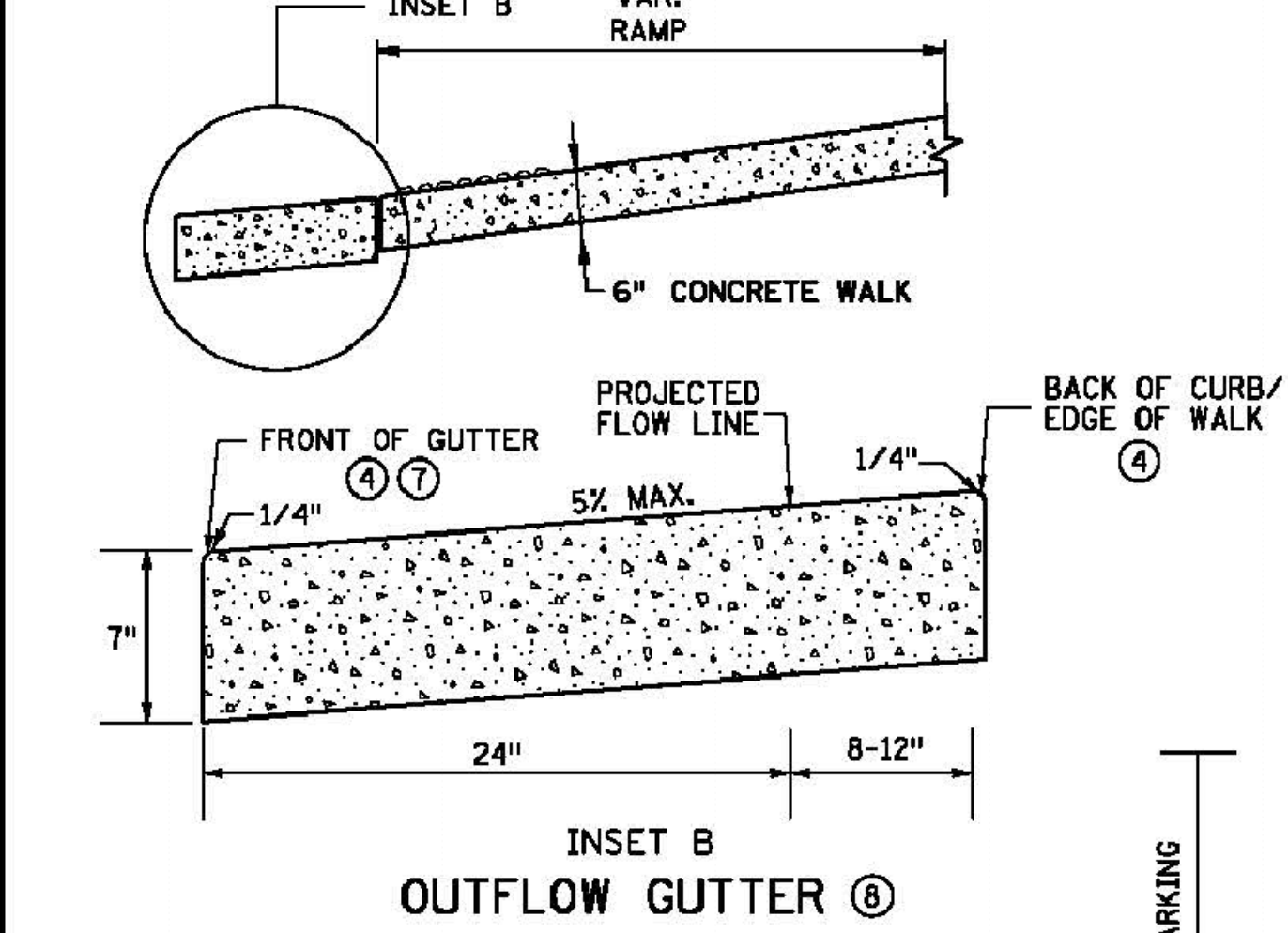

PAVEMENT TREATMENT OPTIONS IN FRONT OF CURB & GUTTER
FOR USE ON CURB RAMP RETROFITS

- NOTES:**
- POSITIVE FLOW LINE DRAINAGE SHALL BE MAINTAINED THROUGH THE PEDESTRIAN ACCESS ROUTE (PAR) AT A 2% MAXIMUM. NO PONDING SHALL BE PRESENT IN THE PAR.
 - ANY VERTICAL LIP THAT OCCURS AT THE FLOW LINE SHALL NOT BE GREATER THAN 1/4 INCH.
 - ① FOR USE AT CURB CUTS WHERE THE PEDESTRIAN'S PATH OF TRAVEL IS ASSUMED PERPENDICULAR TO THE GUTTER FLOW LINE. RAMP TYPES INCLUDE: PERPENDICULAR, TIERED PERPENDICULAR, PARALLEL, AND DIAGONAL RAMPS.
 - ② FOR USE AT CURB RAMPS WHERE THE PEDESTRIAN'S PATH OF TRAVEL IS ASSUMED NON PERPENDICULAR TO THE GUTTER FLOW LINE. RAMP TYPES INCLUDE: FANS & DEPRESSED CORNERS.
 - ③ BEGIN GUTTER SLOPE TRANSITION 10' OUTSIDE OF ALL CURB RAMPS.
 - ④ THERE SHALL BE NO VERTICAL DISCONTINUITIES GREATER THAN 1/4".
 - ⑤ ELEVATION CHANGE TAKES PLACE FROM THE EXISTING TO NEW FRONT OF GUTTER. PATCH IS USED TO MATCH THE NEW GUTTER FACE INTO THE EXISTING ROADWAY.
 - ⑥ VARIABLE WIDTH FOR DIRECTIONAL CURB APPLICATIONS. SEE SHEET 2 FOR DIRECTIONAL CURB SLOPE REQUIREMENTS.
 - ⑦ TOP FRONT OF GUTTER SHALL BE CONSTRUCTED FLUSH WITH PROPOSED ADJACENT PAVEMENT ELEVATION. TOP 1.5" OF THE GUTTER FACE MUST BE A FORMED EDGE. PAR GUTTER SHALL NOT BE OVERLAID.
 - ⑧ SHOULD BE USED AT VERTICALLY CONSTRAINED AREAS WHEN AT A DRAINAGE HIGH POINT OR SUPER ELEVATED ROADWAY SEGMENTS.
 - ⑨ DRILL AND GROUT NO. 4 EPOXY-COATED 18" LONG TIE BARS AT 30" CENTER TO CENTER INTO EXISTING CONCRETE PAVEMENT 1" MINIMUM FROM ALL JOINTS.
 - ⑩ HELPS PROVIDE TWO SEPARATE RAMPS, REDUCES THE DOME SETBACK LENGTH AND MINIMIZES DIRECTIONAL CURB. THIS RADIUS DESIGN CLOSELY FOLLOWS THE TURNING VEHICLE PATH WHILE OPTIMIZING CURB RAMP LENGTH.
 - ⑪ CURB EXTENSIONS SHOULD BE USED IN VERTICALLY CONSTRAINED AREAS, USUALLY IN DOWNTOWN ROADWAY SEGMENTS WHERE ON-STREET PARKING IS AVAILABLE. CURB EXTENSIONS SHOULD BE CONSIDERED FOR APS INTERSECTIONS WHERE SPACE IS LIMITED. PUSH BUTTONS MUST MEET APS CRITERIA AS DESCRIBED IN THE PUSH BUTTON LOCATION DETAIL SHEET.
 - ⑫ PLACE BOND BREAKER BETWEEN WALK AND TOP OF SILL.
 - ⑬ 1/2" PREFORMED JOINT FILLER PER MNDOT SPEC. 3702.
 - ⑭ DIMENSION TO BE SAME AS SIDEWALK THICKNESS, 4" MIN.

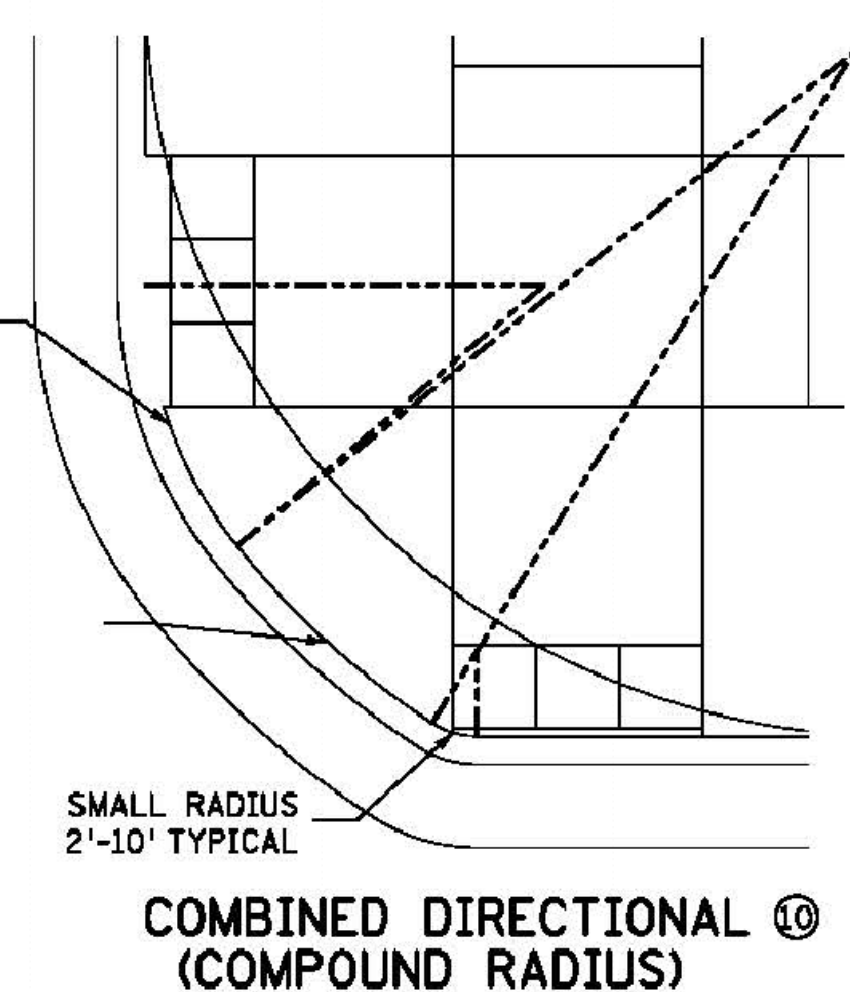
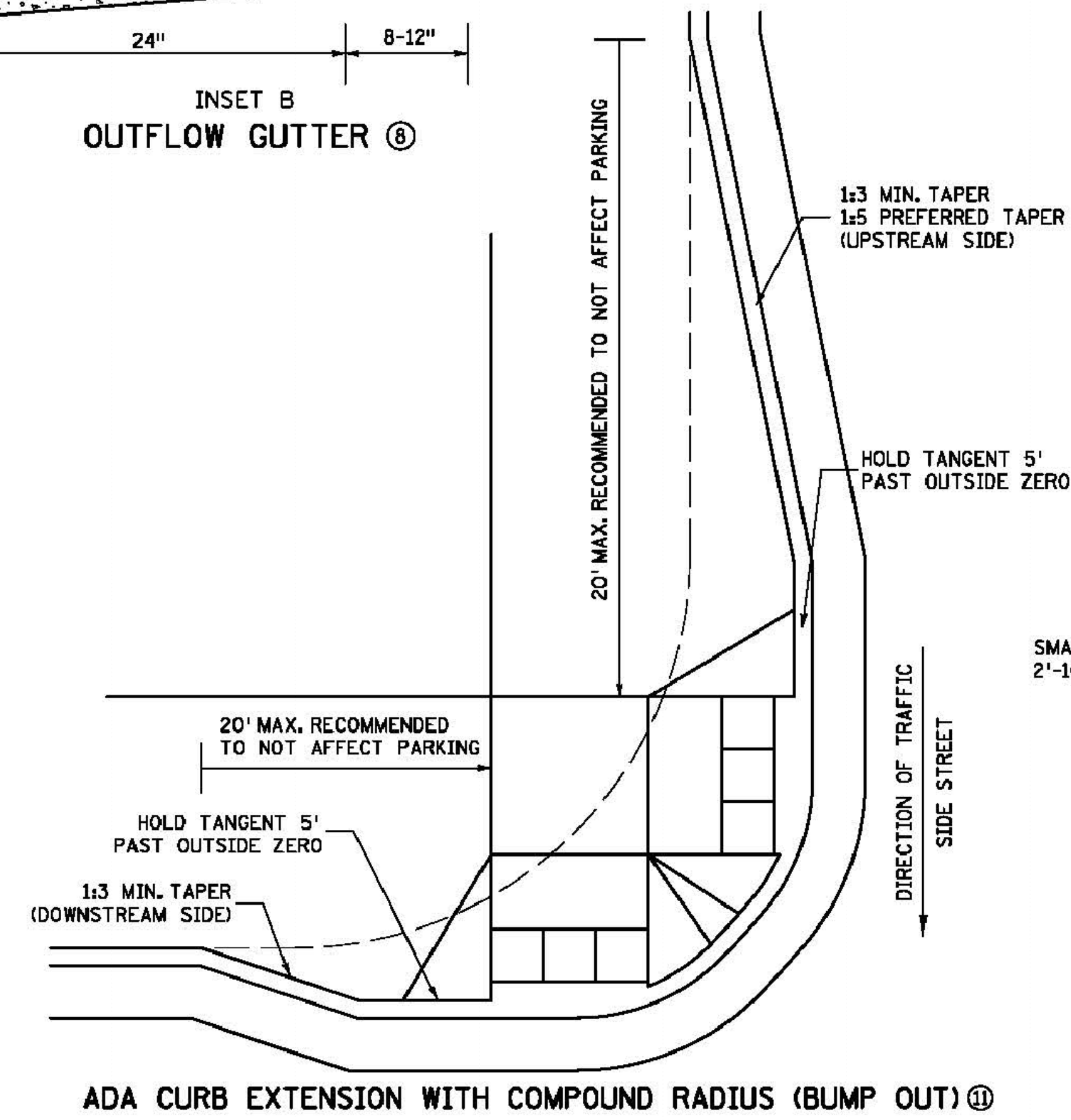

REVISION:
APPROVED: JANUARY 23, 2017
<i>[Signature]</i> OPERATIONS ENGINEER

DIRECTION OF TRAFFIC
MAIN STREET

	STANDARD PLAN 5-297.250	3 OF 6	PEDESTRIAN CURB RAMP DETAILS		
	STATE PROJ. NO.	(T.H.)	SHEET NO.	OF	SHEETS

I HEREBY CERTIFY THAT THIS PLAN, SPECIFICATION, OR REPORT WAS PREPARED BY ME OR UNDER MY DIRECT SUPERVISION AND I AM A DULY LICENSED PROFESSIONAL ENGINEER UNDER THE LAWS OF THE STATE OF MINNESOTA.
DATE _____ Mark Welch
REG. NO. _____

DESIGNED	DJT	REVISION	BY	DATE	LATEST REVISION: 1-28-2019
DRAWN					Prepared For: Andy Baartman 1489 Hay Creek Valley Rd Red Wing, MN 55066
CHECKED					FILE NO.: 07124 Baartman

CITY OF RED WING
GOODHUE COUNTY, MINNESOTA
2018 CONSTRUCTION

PARK PLACE
APARTMENTS

PLOTTED/REVISED: 4-APR-2018

IPLOT NAME: s250-4.spp
 PATH & FILENAME: DT:\S:\DesignStandards\Development\New Border\200_Surfaces\250_4.spp.dgn

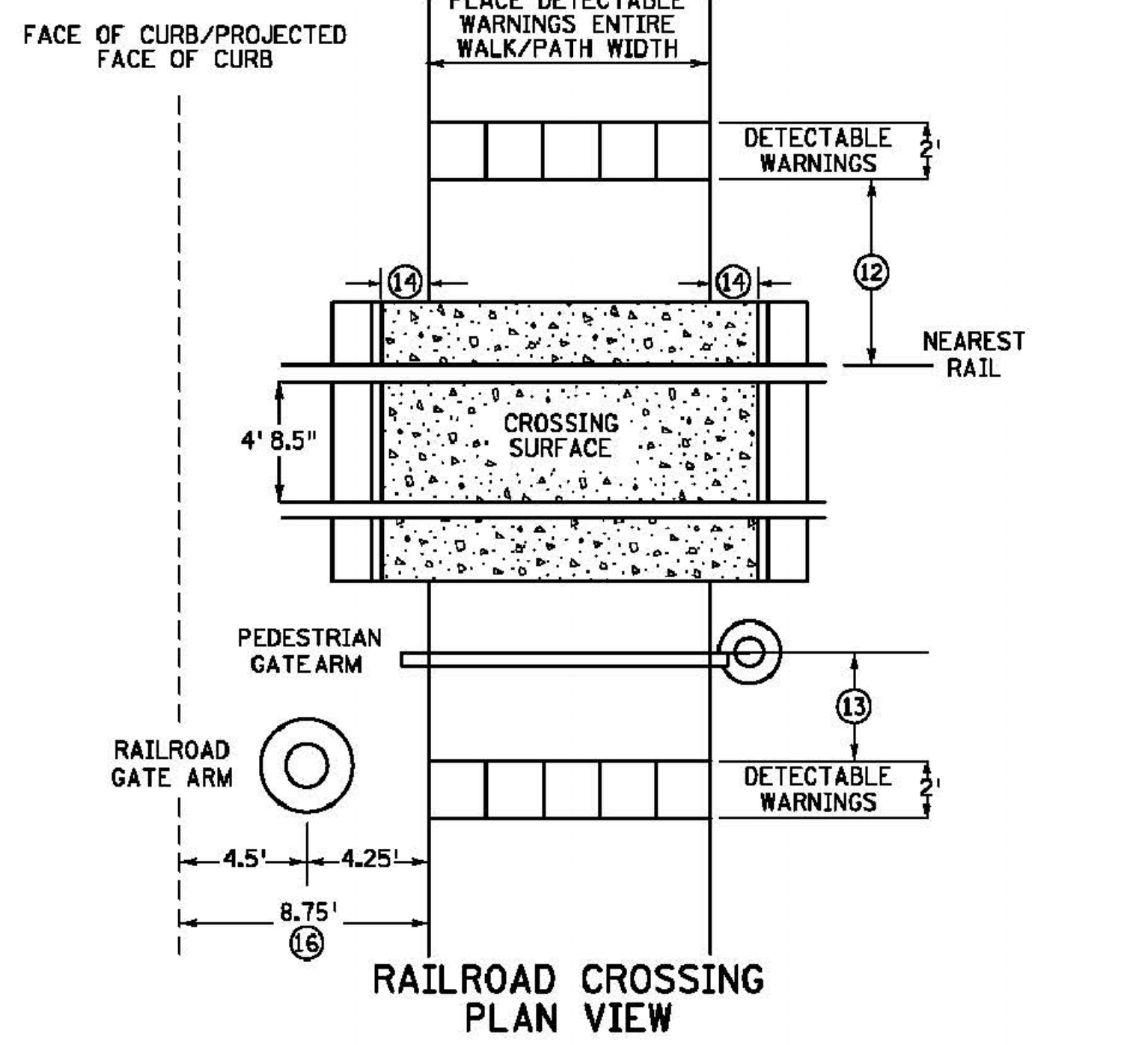
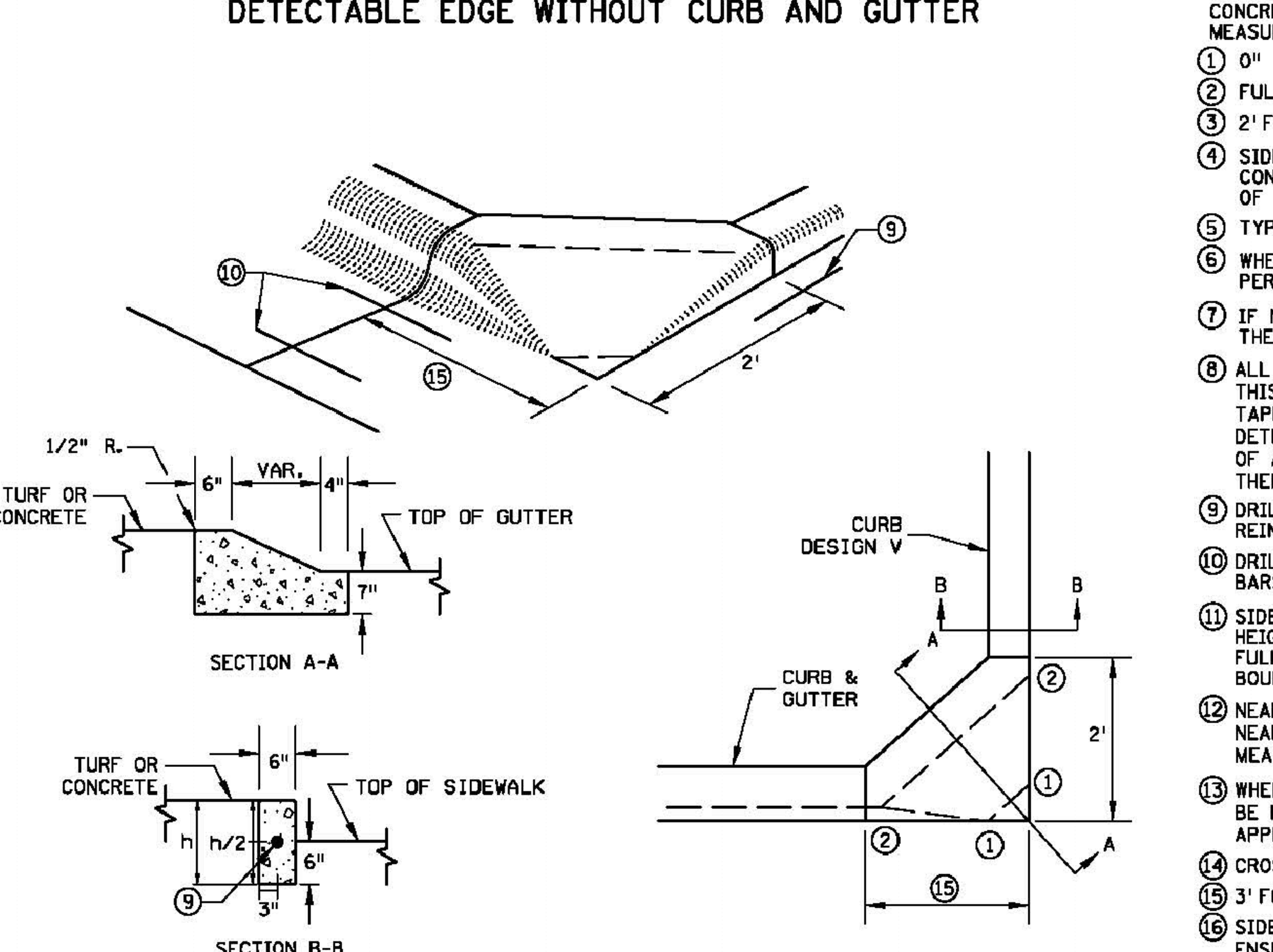
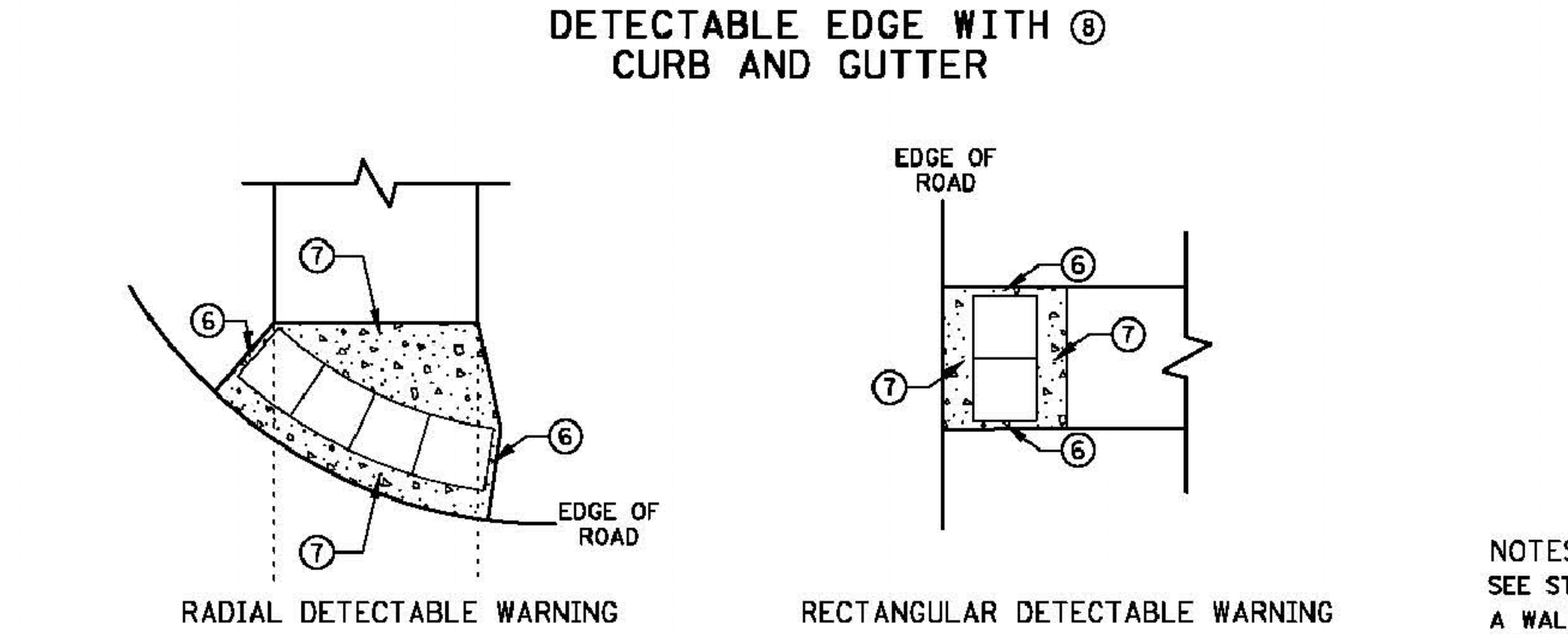
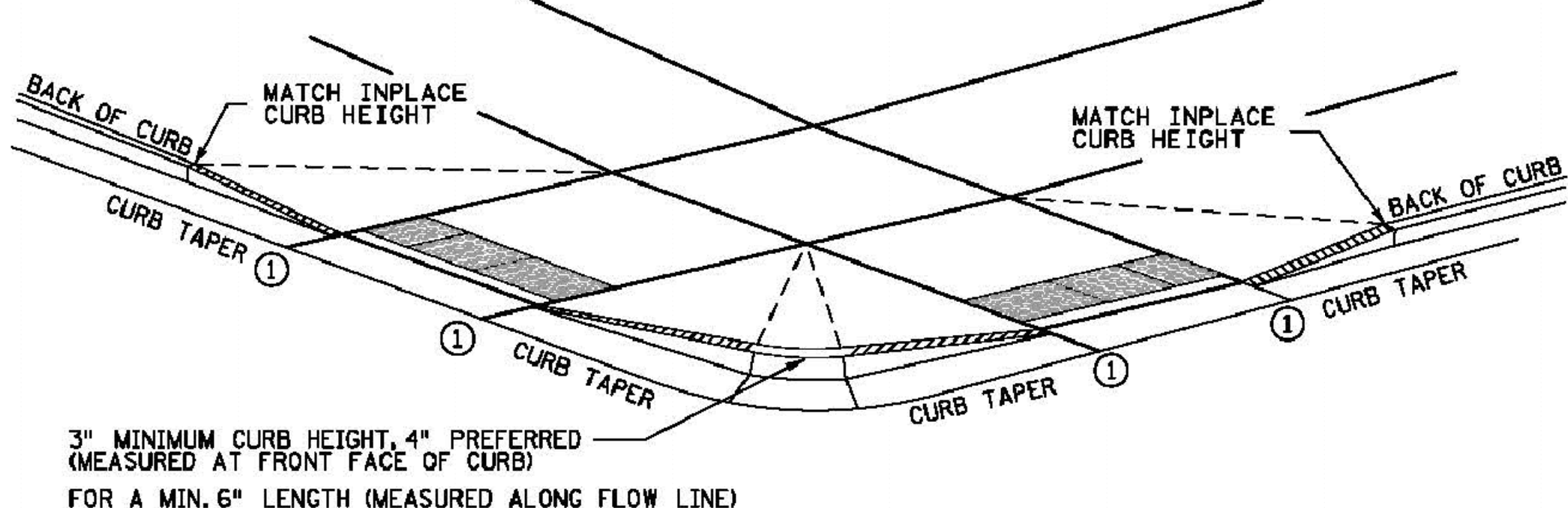
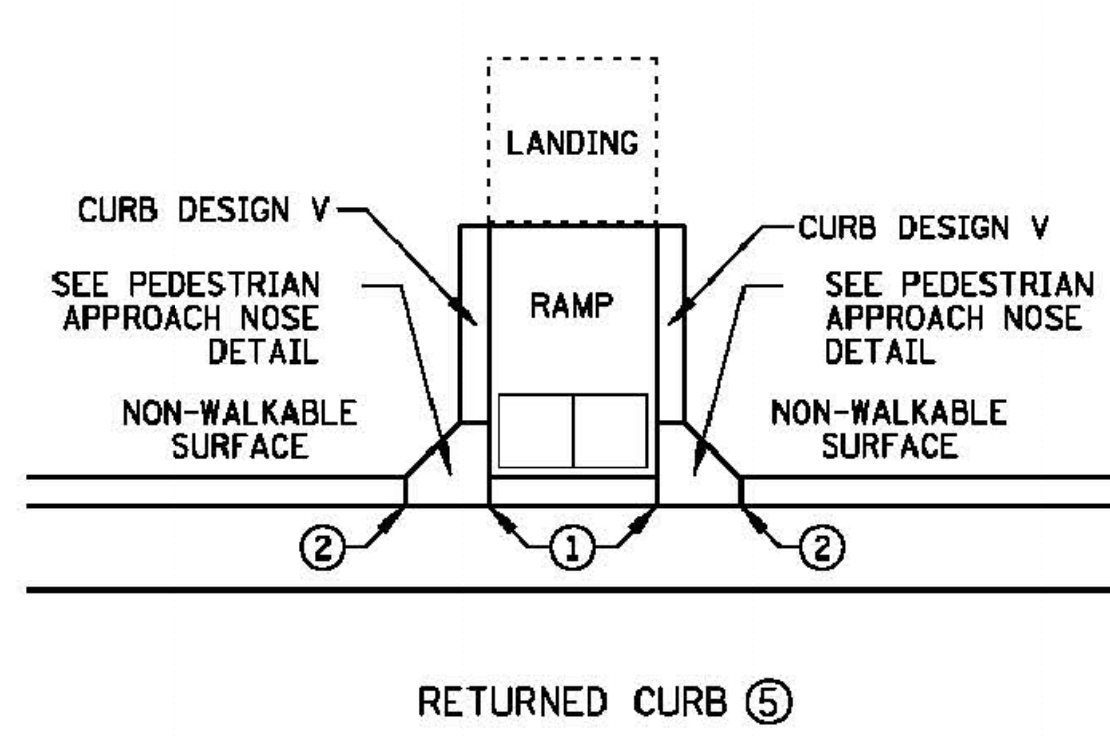
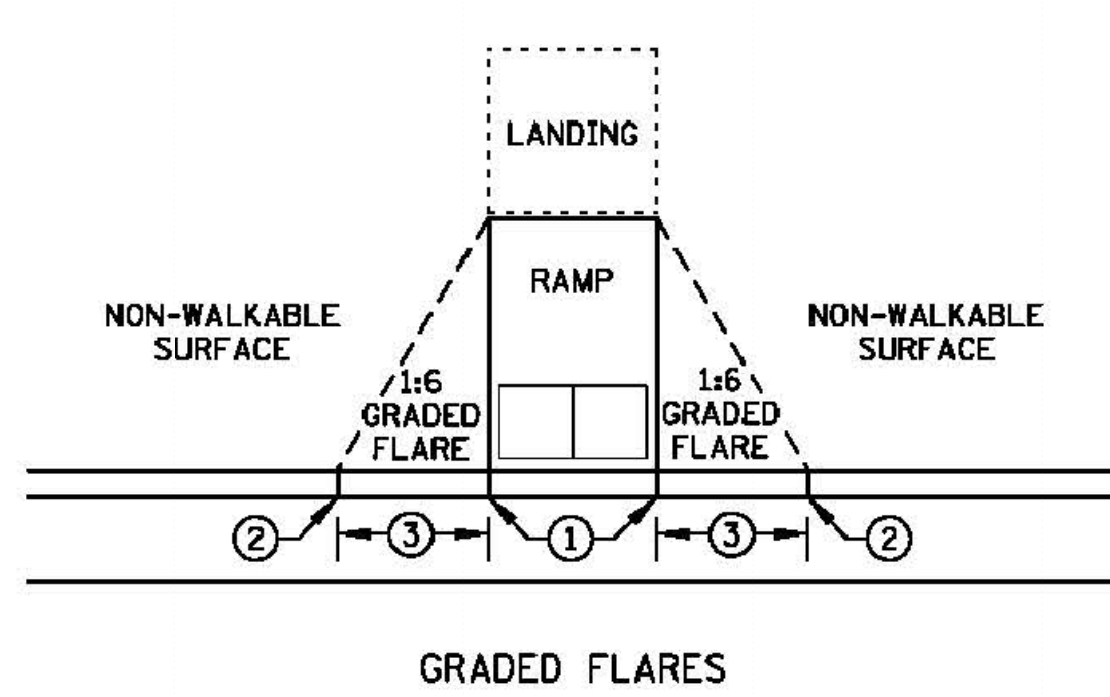
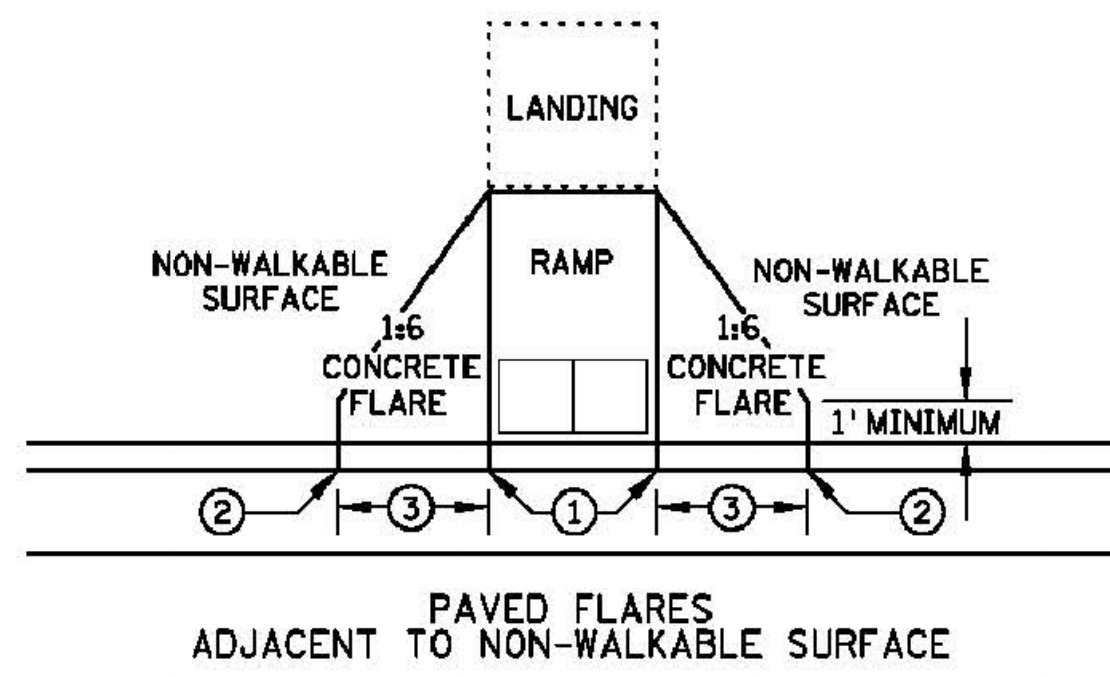
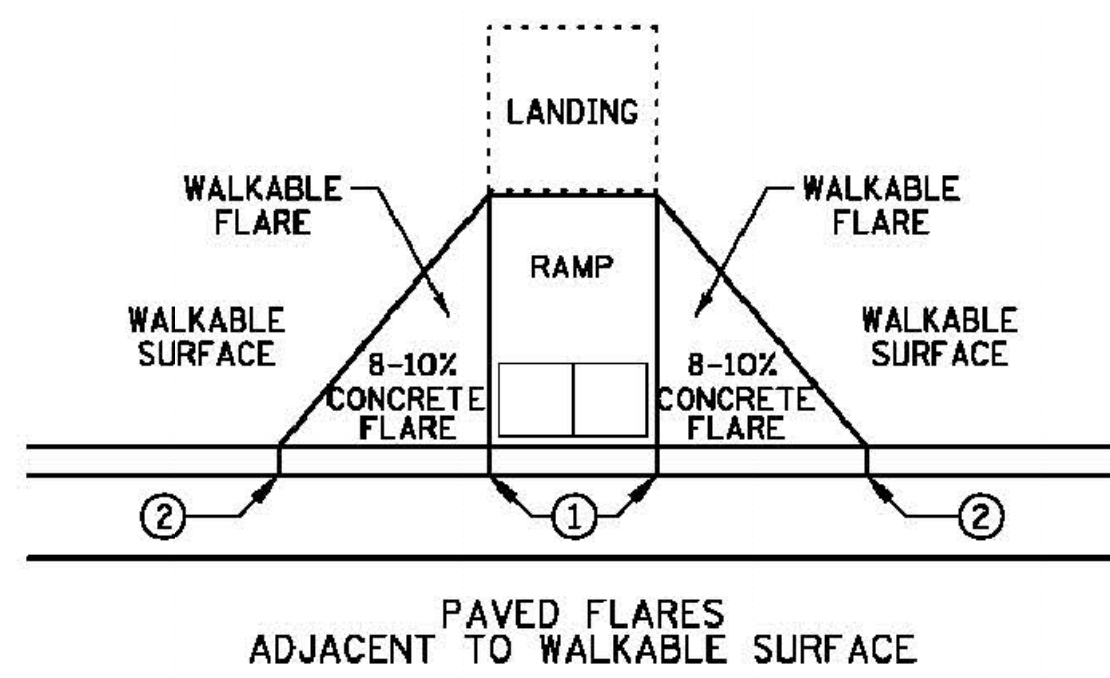

- NOTES:
- SEE STANDARD PLATE 7038 AND THIS SHEET FOR ADDITIONAL DETAILS ON DETECTABLE WARNING.
 - A WALKABLE SURFACE IS DEFINED AS A PAVED SURFACE ADJACENT TO A CURB RAMP WITHOUT RAISED OBSTACLES THAT COULD MISTAKENLY BE TRAVERSED BY A USER WHO IS VISUALLY IMPAIRED.
 - CONCRETE FLARE LENGTHS ADJACENT TO NON-WALKABLE SURFACES SHOULD BE LESS THAN 8' LONG MEASURED ALONG THE RAMPS FROM THE BACK OF CURB.
 - ① 0" CURB HEIGHT.
 - ② FULL CURB HEIGHT.
 - ③ 2' FOR 4" HIGH CURB AND 3' FOR 6" HIGH CURB.
 - ④ SIDE TREATMENTS ARE APPLICABLE TO ALL RAMP TYPES AND SHOULD BE IMPLEMENTED AS NEEDED AS FIELD CONDITIONS DICTATE. THE ENGINEER SHALL DETERMINE THE RAMP SIDE TREATMENTS BASED ON MAINTENANCE OF BOTH ROADWAY AND SIDEWALK, ADJACENT PROPERTY CONSIDERATIONS, AND MITIGATING CONSTRUCTION IMPACTS.
 - ⑤ TYPICALLY USED FOR MEDIANS AND ISLANDS.
 - ⑥ WHEN NO CONCRETE FLARES ARE PROPOSED, THE CONCRETE WALK SHALL BE FORMED AND CONSTRUCTED PERPENDICULAR TO THE EDGE OF ROADWAY. MAINTAIN 3" MAX. BETWEEN EDGE OF DOMES AND EDGE OF CONCRETE.
 - ⑦ IF NO CURB AND GUTTER IS PLACED IN RURAL SECTIONS, DETECTABLE WARNINGS SHALL BE PLACED 1' FROM THE EDGE OF BITUMINOUS ROADWAY AND/OR BITUMINOUS SHARED-USE PATH TO PROVIDE VISUAL CONTRAST.
 - ⑧ ALL CONSTRUCTED CURBS MUST HAVE A CONTINUOUS DETECTABLE EDGE FOR THE VISUALLY IMPAIRED. THIS DETECTABLE EDGE REQUIRES DETECTABLE WARNINGS WHEREVER THERE IS ZERO-INCH HIGH CURB. CURB TAPERS ARE CONSIDERED A DETECTABLE EDGE WHEN THE TAPER STARTS WITHIN 3" OF THE EDGE OF THE DETECTABLE WARNINGS AND UNIFORMLY RISES TO A 3-INCH MINIMUM CURB HEIGHT. ANY CURB NOT PART OF A CURB TAPER AND LESS THAN 3 INCHES IN HEIGHT IS NOT CONSIDERED A DETECTABLE EDGE AND THEREFORE IS NOT COMPLIANT WITH ACCESSIBILITY STANDARDS.
 - ⑨ DRILL AND GROUT 1 - NO. 4 12" LONG REINFORCEMENT BAR (EPOXY COATED) WITH 3" MIN. COVER. REINFORCEMENT BARS ARE NOT NEEDED IF THE APPROACH NOSE IS POURED INTEGRAL WITH THE V CURB.
 - ⑩ DRILL AND GROUT 2 - NO. 4 12" LONG REINFORCEMENT BARS (EPOXY COATED) WITH 3" MIN. COVER. REINFORCEMENT BARS ARE NOT NEEDED IF THE APPROACH NOSE IS POURED INTEGRAL WITH THE CURB AND GUTTER.
 - ⑪ SIDE TREATMENT EXAMPLES SHOWN ARE WHEN THE INITIAL LANDING IS APPROXIMATELY LEVEL WITH THE FULL HEIGHT CURB (I.E. 6" LONG RAMP FOR 6" HIGH CURB). WHEN THE INITIAL LANDING IS MORE THAN 1" BELOW FULL HEIGHT CURB REFER TO SHEETS 1 & 2 TO MODIFY THE CURB HEIGHT TAPERS AND MAINTAIN POSITIVE BOULEVARD DRAINAGE.
 - ⑫ NEAREST EDGE OF DETECTABLE WARNING SURFACES SHALL BE PLACED 12' MINIMUM TO 15' MAXIMUM FROM THE NEAREST RAIL. FOR SKEWED RAILWAYS IN NO INSTANCE SHALL THE DETECTABLE WARNING BE CLOSER THAN 12' MEASURED PERPENDICULAR TO THE NEAREST RAIL.
 - ⑬ WHEN PEDESTRIAN GATES ARE PROVIDED, DETECTABLE WARNING SURFACES SHALL BE PLACED ON THE SIDE OF THE GATES OPPOSITE THE RAIL, 2' FROM THE APPROACHING SIDE OF THE GATE ARM. THIS CRITERIA GOVERNS OVER NOTE ⑫.
 - ⑭ CROSSING SURFACE SHALL EXTEND 2' MINIMUM PAST THE OUTSIDE EDGE OF WALK OR SHARED-USE PATH.
 - ⑮ 3' FOR MEDIANS AND SPLITTER ISLANDS. NOSE CAN BE REDUCED TO 2' ON FREE RIGHT ISLANDS.
 - ⑯ SIDEWALK TO BE PLACED 8.75' MIN. FROM THE FACE OF CURB/PROJECTED FACE OF CURB. THIS ENSURES MIN. CLEARANCE BETWEEN THE SIDEWALK AND GATE ARM COUNTERWEIGHT SUPPORTS.

REVISION:
APPROVED: JANUARY 23, 2017
<i>[Signature]</i>
OPERATIONS ENGINEER

PEDESTRIAN APPROACH NOSE DETAIL
 (FOR RETURNED CURB SIDE TREATMENT)



STANDARD PLAN 5-297.250 4 OF 6
 APPROVED: 1-23-2017
 REVISED:
 STATE PROJ. NO. (T.H.) SHEET NO. OF SHEETS

PEDESTRIAN CURB RAMP DETAILS

G³ G-Cubed Inc.
 Engineering
 Surveying
 Planning
 285 Westview Drive
 West Saint Paul, MN 55118
 ph. 651.288.1100 fax 651.455.4948

I HEREBY CERTIFY THAT THIS PLAN, SPECIFICATION, OR REPORT WAS PREPARED BY ME OR UNDER MY DIRECT SUPERVISION AND I AM A DULY LICENSED PROFESSIONAL ENGINEER UNDER THE LAWS OF THE STATE OF MINNESOTA.
 DATE _____ Mark Welch
 REG. NO. _____

DESIGNED	REVISOR	BY	DATE
DJT			
DRAWN			
CHECKED			

LATEST REVISION: 1-28-2019
 Prepared For:
 Andy Baartman
 1489 Hay Creek Valley Rd
 Red Wing, MN 55066
 FILE NO.: 07124 Baartman

CITY OF RED WING
 GOODHUE COUNTY, MINNESOTA
 2018 CONSTRUCTION

PARK PLACE
 APARTMENTS

MNDOT STANDARD
 DETAILS
 SHEET 11 OF 13 SHEETS

PLOTTED/REVISED: 4-APR-2018

I PLOT NAME: s250_5_spp
 PATH & FILENAME: OT\S\DesignStandards\Development\New Border\200_Series\s250_5_spp.dgn

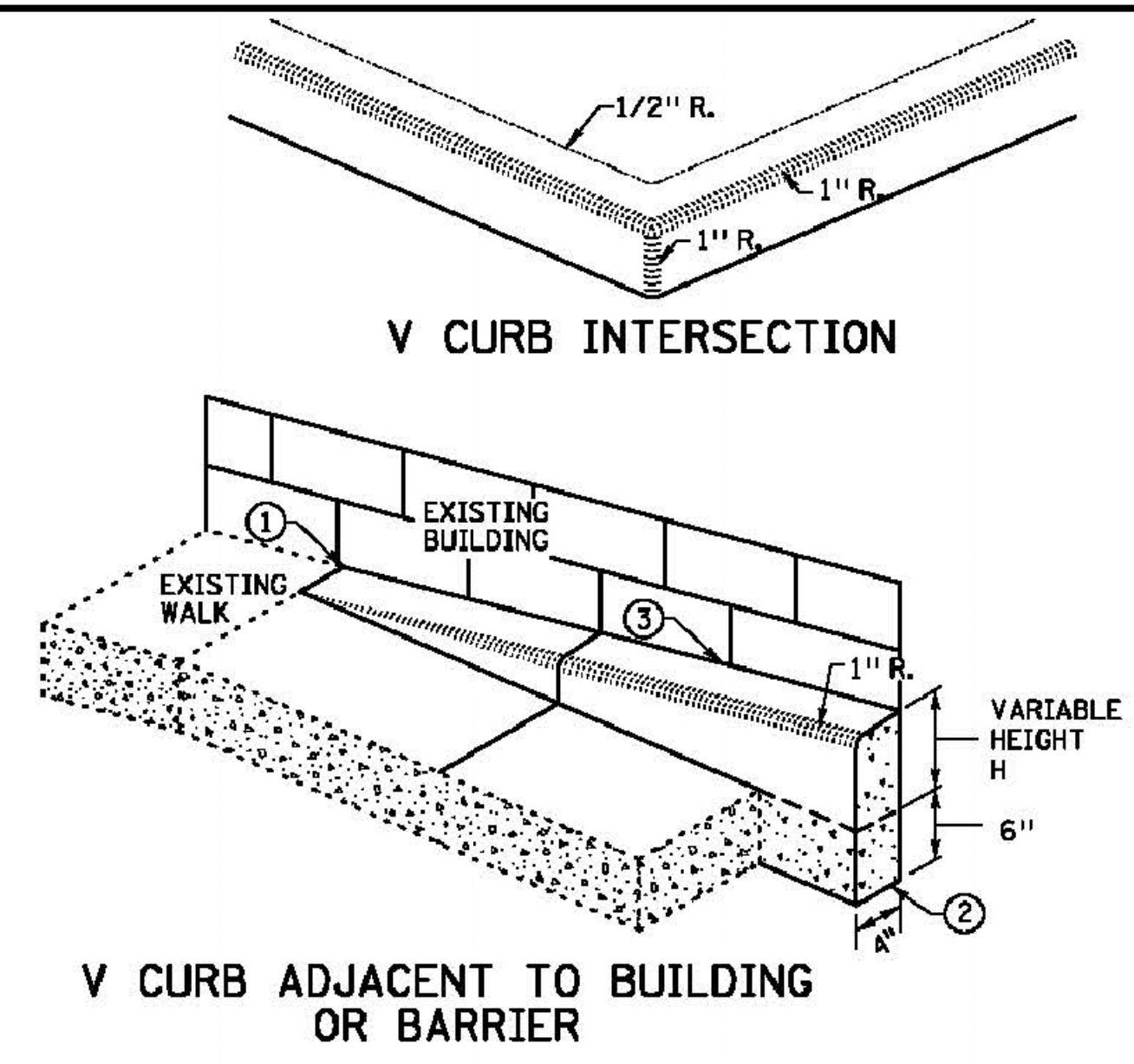
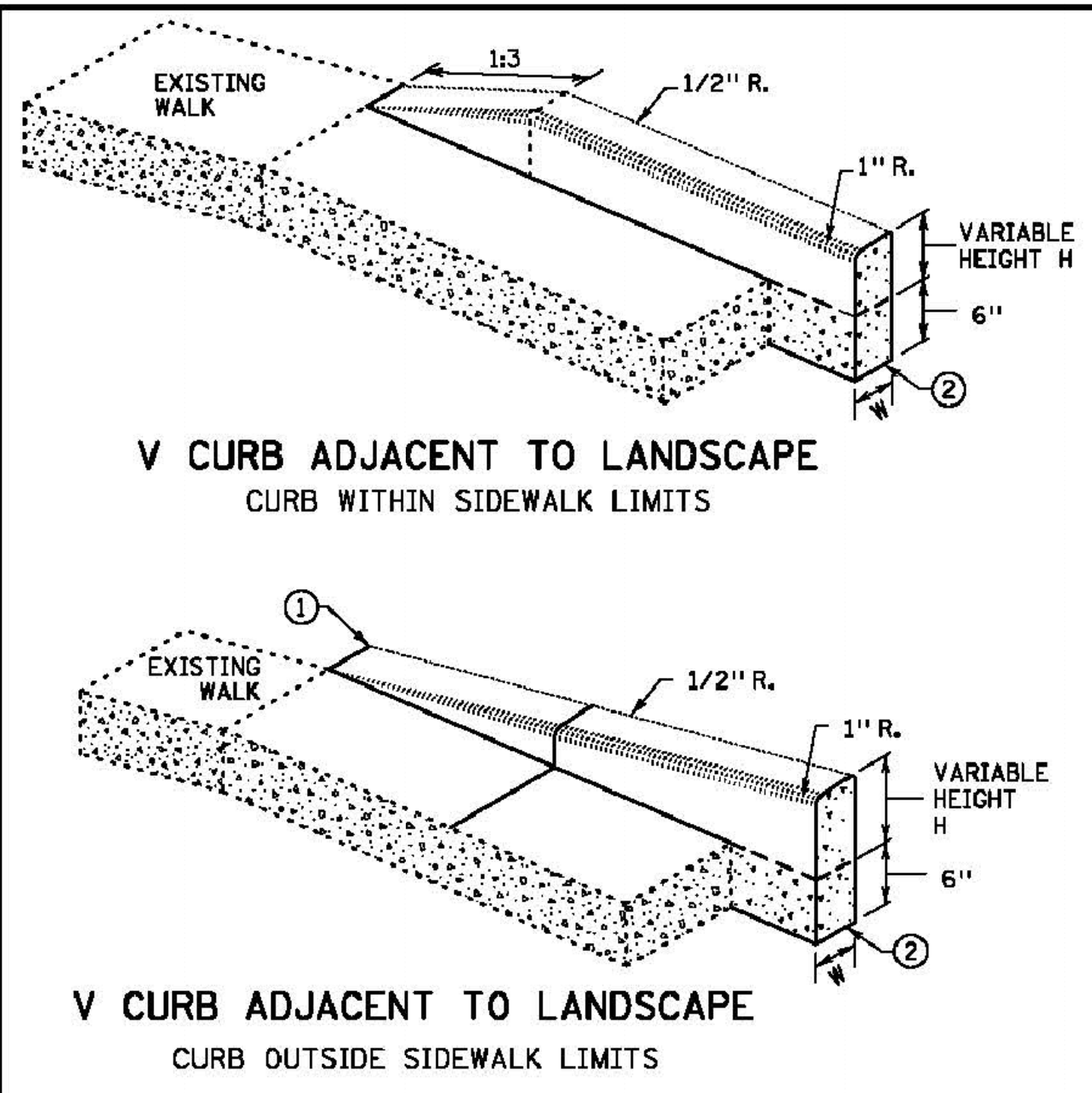

CONCRETE CURB DESIGN V	
CURB HEIGHT H	CURB WIDTH W
< 6"	4"
≥ 6"	6"

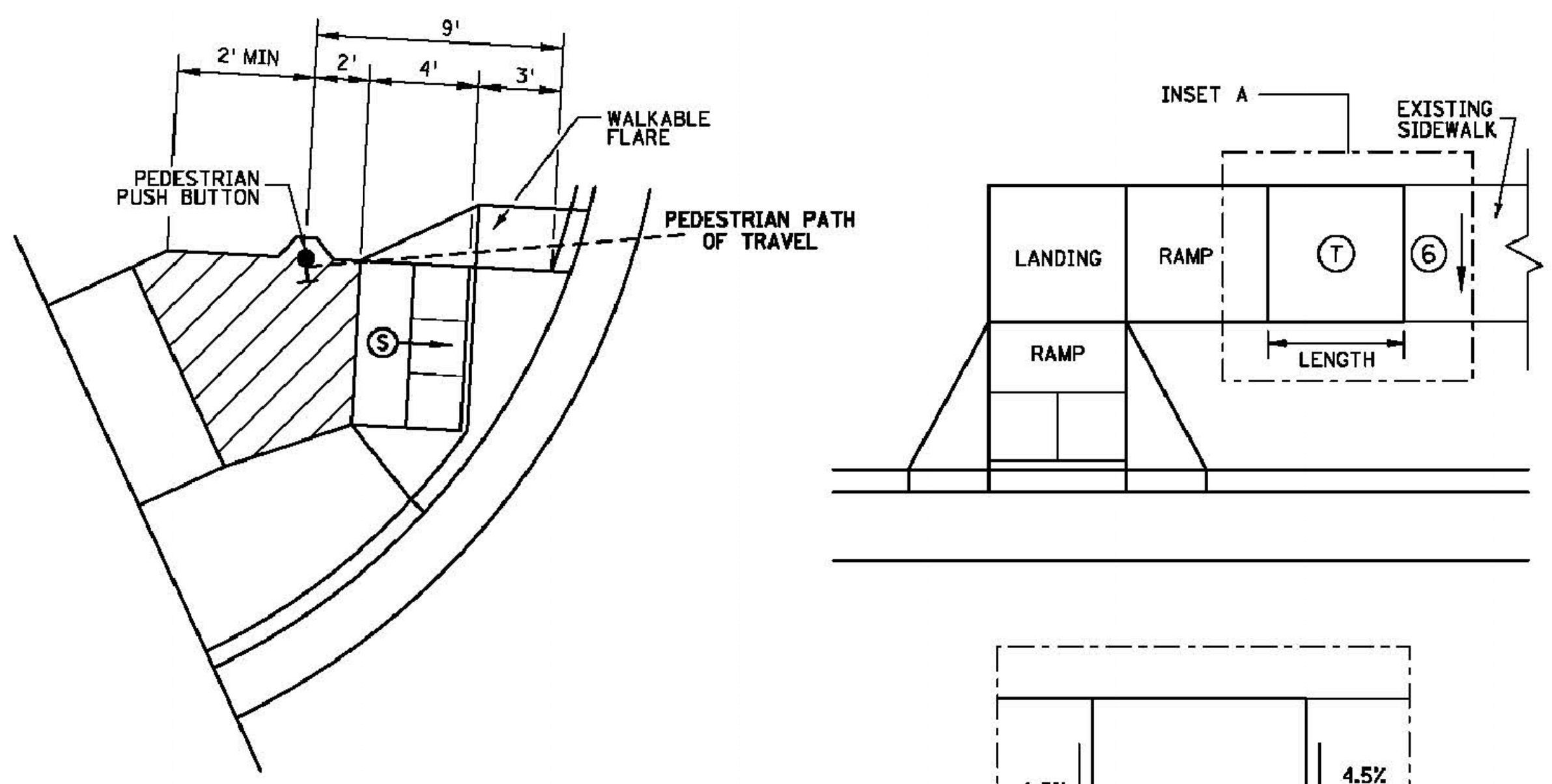

SEMI-DIRECTIONAL RAMP (3,4,9)
 3' DOME SETBACK, 4' LONG RAMP AND
 PUSH BUTTON 9' FROM THE BACK OF CURB
 PRIMARILY USED FOR APS APPLICATIONS
 WHERE THE PAR DOES NOT CONTINUE PAST
 THE PUSH BUTTON (DEAD-END SIDEWALK)

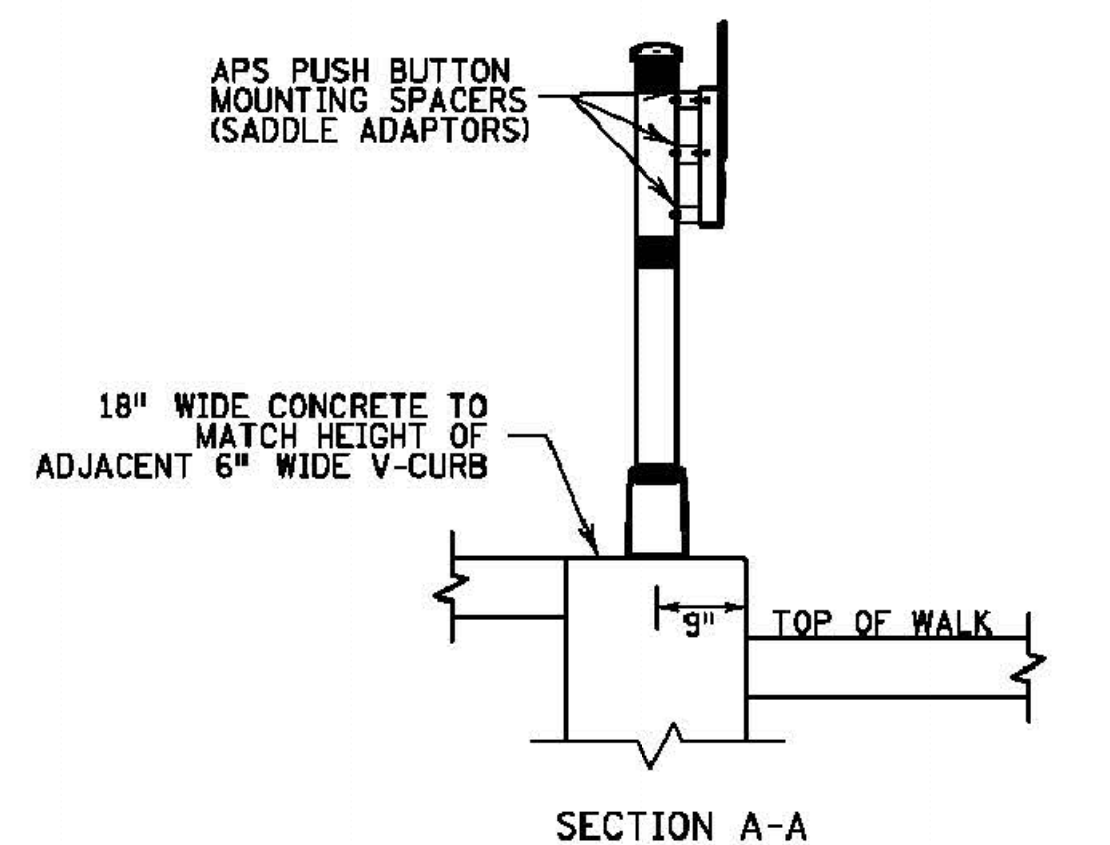
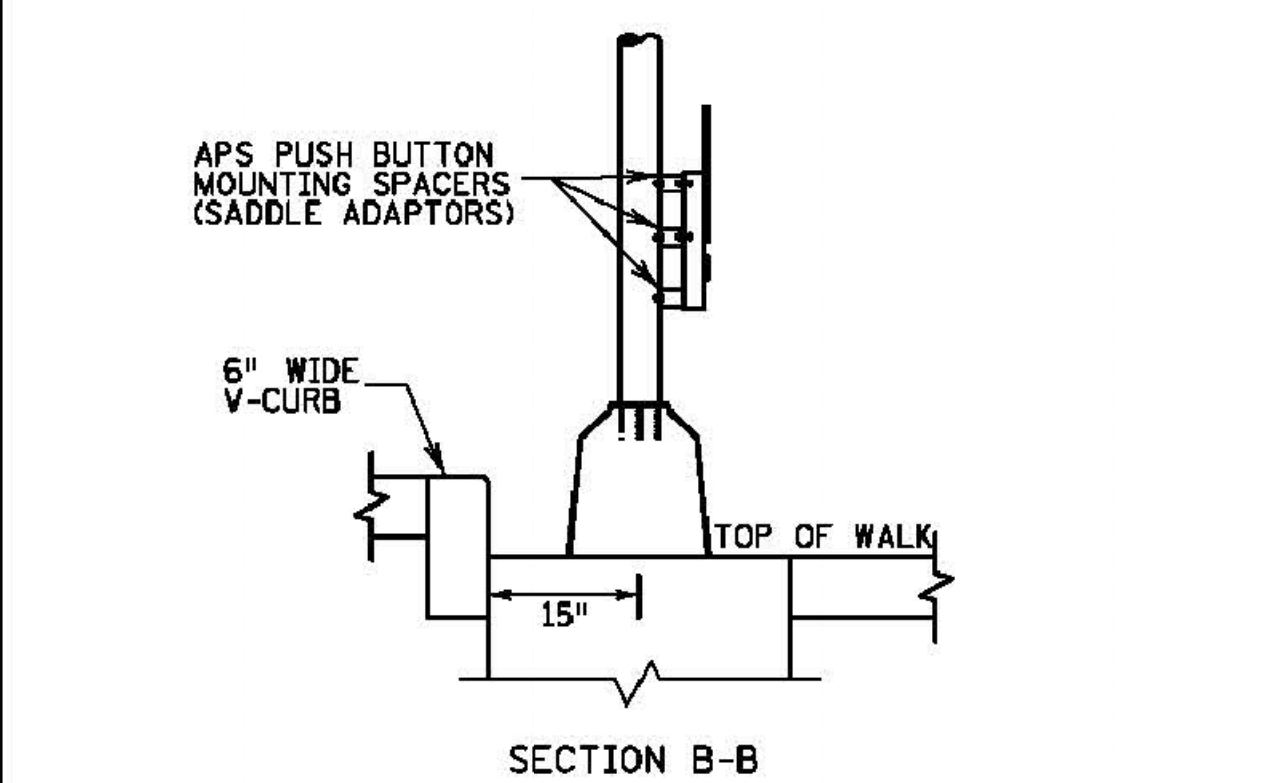
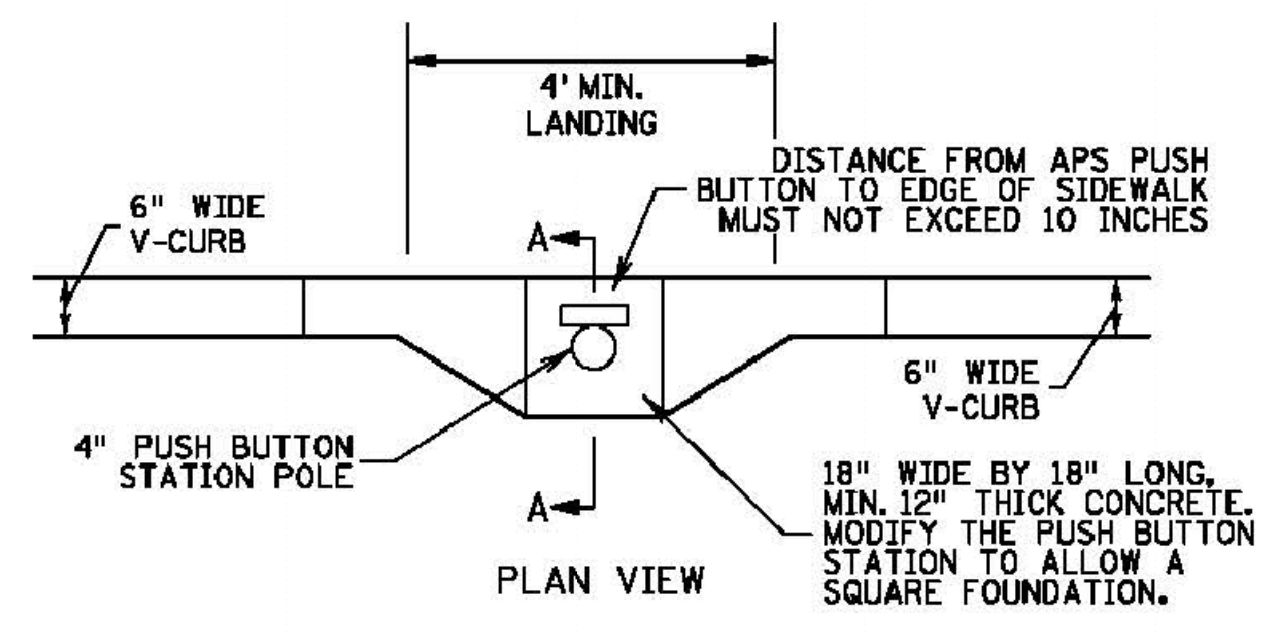
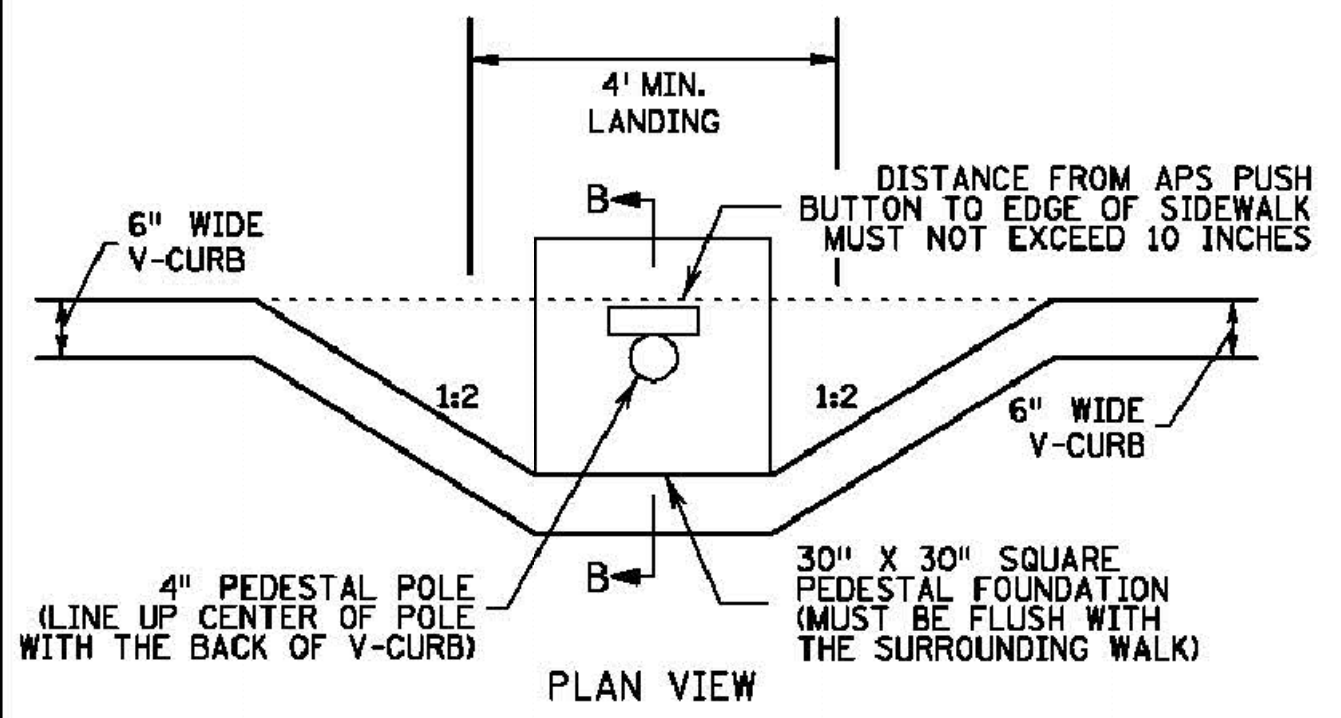

- NOTES:**
- A WALKABLE FLARE IS AN 8-10% CONCRETE FLARE THAT IS REQUIRED WHEN THE FLARE IS ADJACENT TO A WALKABLE SURFACE, OR WHEN THE PEDESTRIAN PATH OF TRAVEL OF A PUSH BUTTON TRAVERSES THE FLARE.
 - ALL V CURB CONTRACTION JOINTS SHALL MATCH CONCRETE WALK JOINTS.
 - WHERE RIGHT-OF-WAY ALLOWS, USE OF V CURB SHOULD BE MINIMIZED. GRADING ADJACENT TURF OR SLOPING ADJACENT PAVEMENT IS PREFERRED.
 - V CURB SHALL BE PLACED OUTSIDE THE SIDEWALK LIMITS WHEN RIGHT OF WAY ALLOWS.
 - V CURB NEXT TO BUILDING SHALL BE A 4" WIDTH AND SHALL MATCH PREVIOUS TOP OF SIDEWALK ELEVATIONS.
 - END TAPERS AT TRANSITION SECTION SHALL MATCH INPLACE SIDEWALK GRADES.
 - ALL V CURB SHALL MATCH BOTTOM OF ADJACENT WALK.
 - EDGE BETWEEN NEW V CURB AND INPLACE STRUCTURE SHALL BE SEALED AND BOND BREAKER SHALL BE USED BETWEEN EXISTING STRUCTURE AND PLACED V-CURB.
 - THE MAX. RATE OF CROSS SLOPE TRANSITIONING IS 1' LINEAR FOOT OF SIDEWALK PER HALF PERCENT CROSS SLOPE. WHEN PAR WIDTH IS GREATER THAN 6' OR THE RUNNING SLOPE IS GREATER THAN 5%, DOUBLE THE CALCULATED TRANSITION LENGTH.
 - TRANSITION PANELS ARE TO ONLY BE USED AFTER THE RAMP, OR IF NEEDED, LANDING ARE AT THE FULL CURB HEIGHT (TYPICAL SECTION).
 - EXISTING CROSS SLOPE GREATER THAN 2.0%.

LEGEND	
(S)	INDICATES PEDESTRIAN RAMP - SLOPE SHALL BE BETWEEN 5.0% MINIMUM AND 8.3% MAXIMUM IN THE DIRECTION SHOWN AND THE CROSS SLOPE SHALL NOT EXCEED 2.0%.
(T)	LANDING AREA - 4' X 4' MIN. (5' X 5' MIN. PREFERRED) DIMENSIONS AND MAX 2.0% SLOPE IN ALL DIRECTIONS. LANDING SHALL BE FULL WIDTH OF INCOMING PAR.
(1)	TRANSITION PANEL(S) - TO BE USED FOR TRANSITIONING THE CROSS-SLOPE OF A RAMP TO THE EXISTING WALK CROSS-SLOPE. RATE OF TRANSITION SHOULD BE 0.5% PER 1 LINEAR FOOT OF WALK. SEE THIS SHEET FOR ADDITIONAL INFORMATION.

REVISION:
 APPROVED: JANUARY 23, 2017
 OPERATIONS ENGINEER

	STANDARD PLAN 5-297.250	5 OF 6	PEDESTRIAN CURB RAMP DETAILS	
		APPROVED: 1-23-2017		
	STATE PROJ. NO.	(T.H.)	SHEET NO.	OF SHEETS

G³ G-Cubed Inc.
 Engineering
 Surveying
 Planning
 285 Westview Drive
 West Saint Paul, MN 55118
 ph. 651.288.1100 fax 651.455.4948

I HEREBY CERTIFY THAT THIS PLAN, SPECIFICATION, OR REPORT WAS PREPARED BY ME OR UNDER MY DIRECT SUPERVISION AND I AM A DULY LICENSED PROFESSIONAL ENGINEER UNDER THE LAWS OF THE STATE OF MINNESOTA.
 DATE _____ Mark Welch
 REG. NO. _____

DESIGNED	DJT	REVISION	BY	DATE	LATEST REVISION: 1-28-2019
DRAWN					Prepared For: Andy Baartman 1489 Hay Creek Valley Rd Red Wing, MN 55066
CHECKED					FILE NO.: 07124 Baartman

CITY OF RED WING
 GOODHUE COUNTY, MINNESOTA
 2018 CONSTRUCTION

PARK PLACE
 APARTMENTS

MNDOT STANDARD
 DETAILS
 SHEET 12 OF 13 SHEETS

PLOTTED/REVISED: 4-APR-2018

IPLLOT NAME: s250_6.spl
PATH & FILENAME: OTS\DesignStandards\DevelopmentNew Border_200_Series\250_6.spl

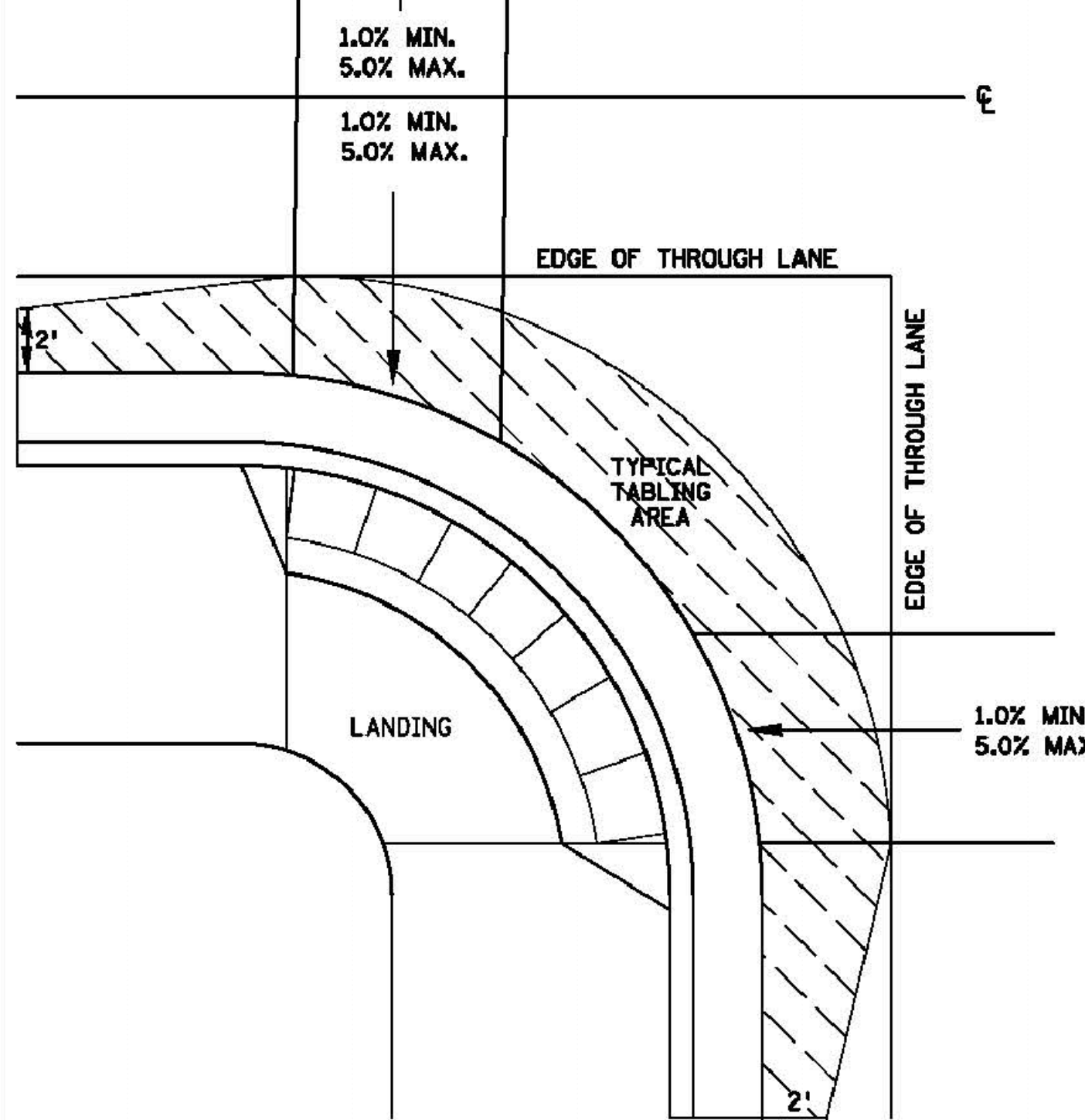
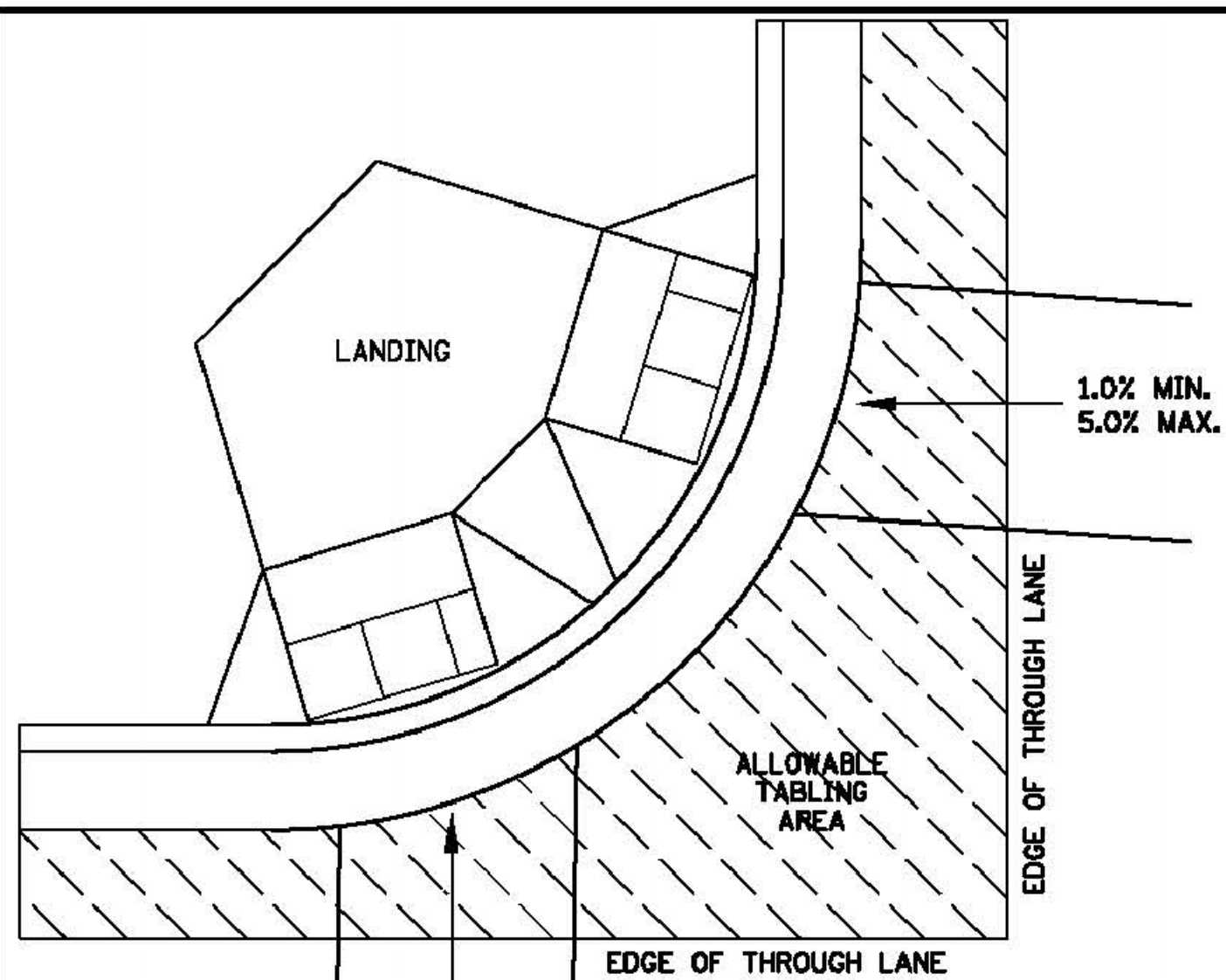

CURB LINE AND ROAD CROSSING ADJUSTMENTS

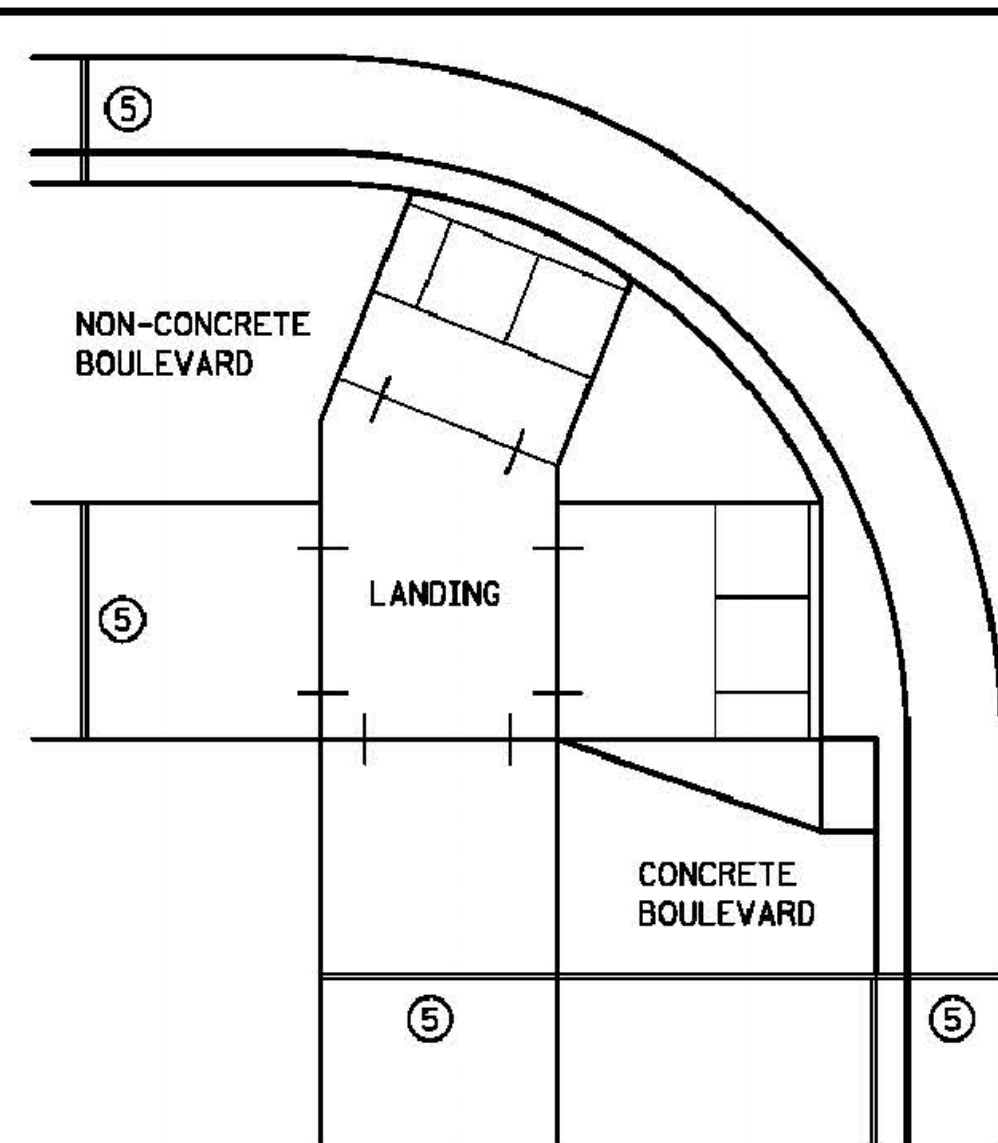

EXPANSION MATERIAL PLACEMENT FOR CONCRETE AND BITUMINOUS ROADWAYS

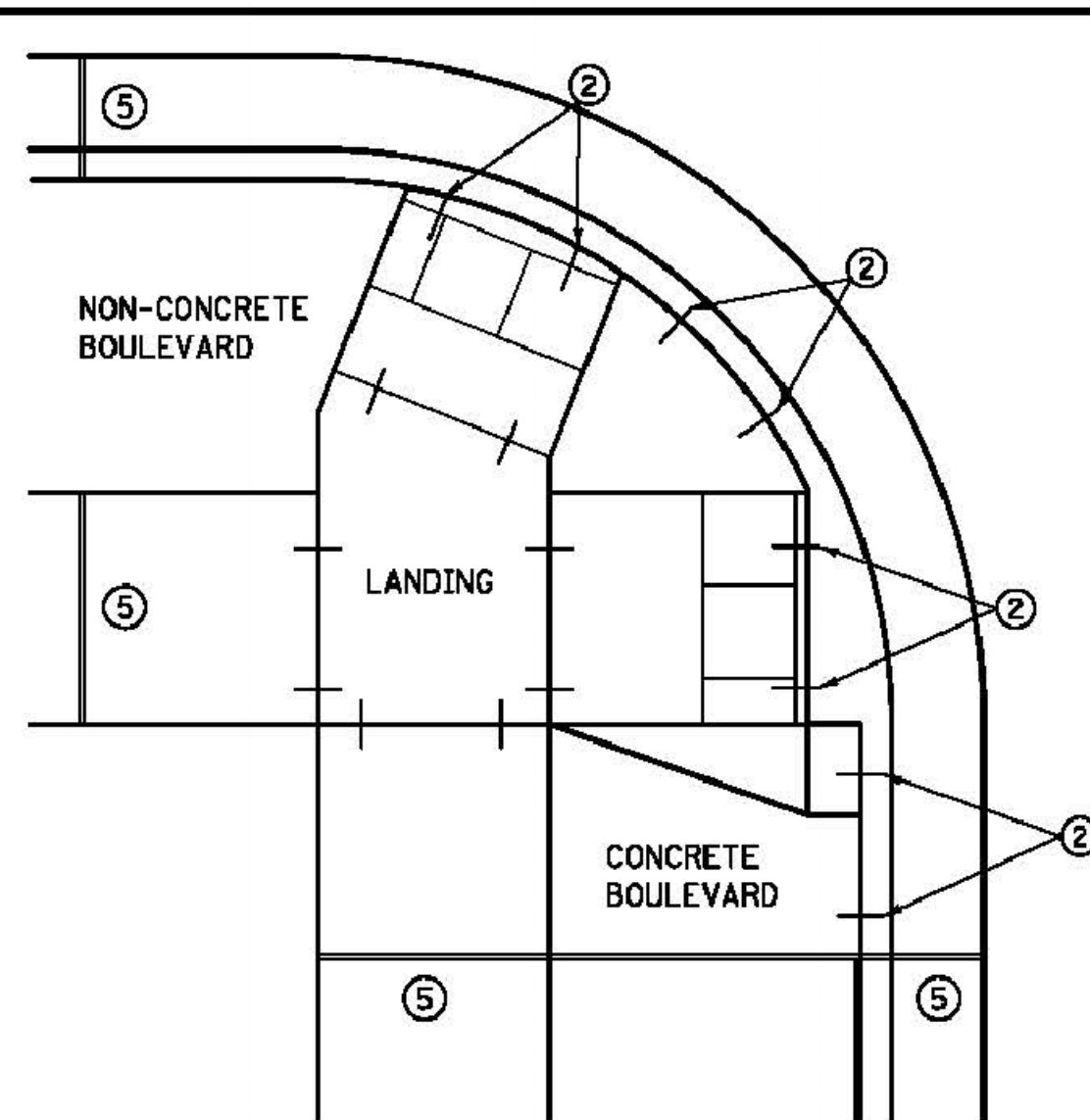

OPTIONAL CURB LINE REINFORCEMENT PLACEMENT ON BITUMINOUS ROADWAYS



FLOW LINE PROFILE "TABLE" - TWIN PERPENDICULARS

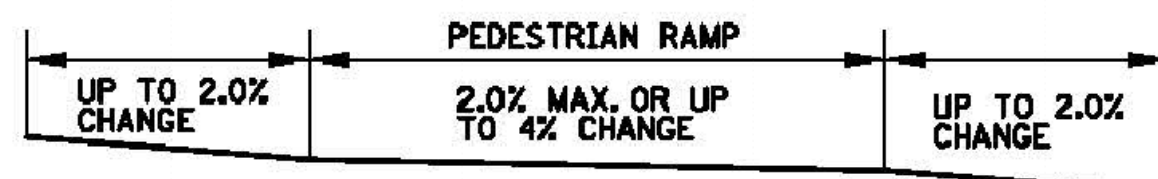

FLOW LINE PROFILE "TABLE" - FAN

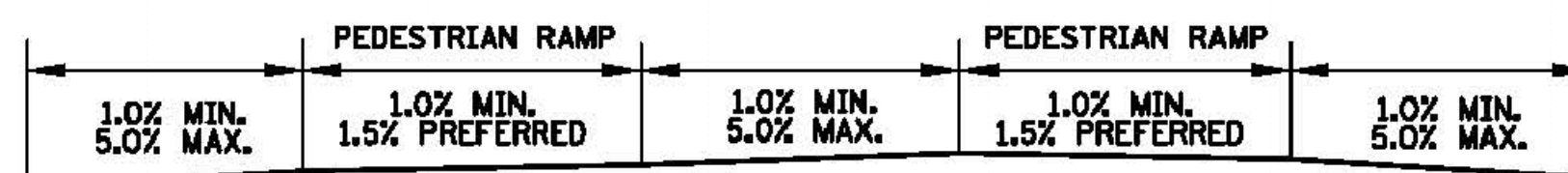

FLOW LINE PROFILE RAISE - TWIN PERPENDICULARS



FLOW LINE PROFILE RAISE - FAN

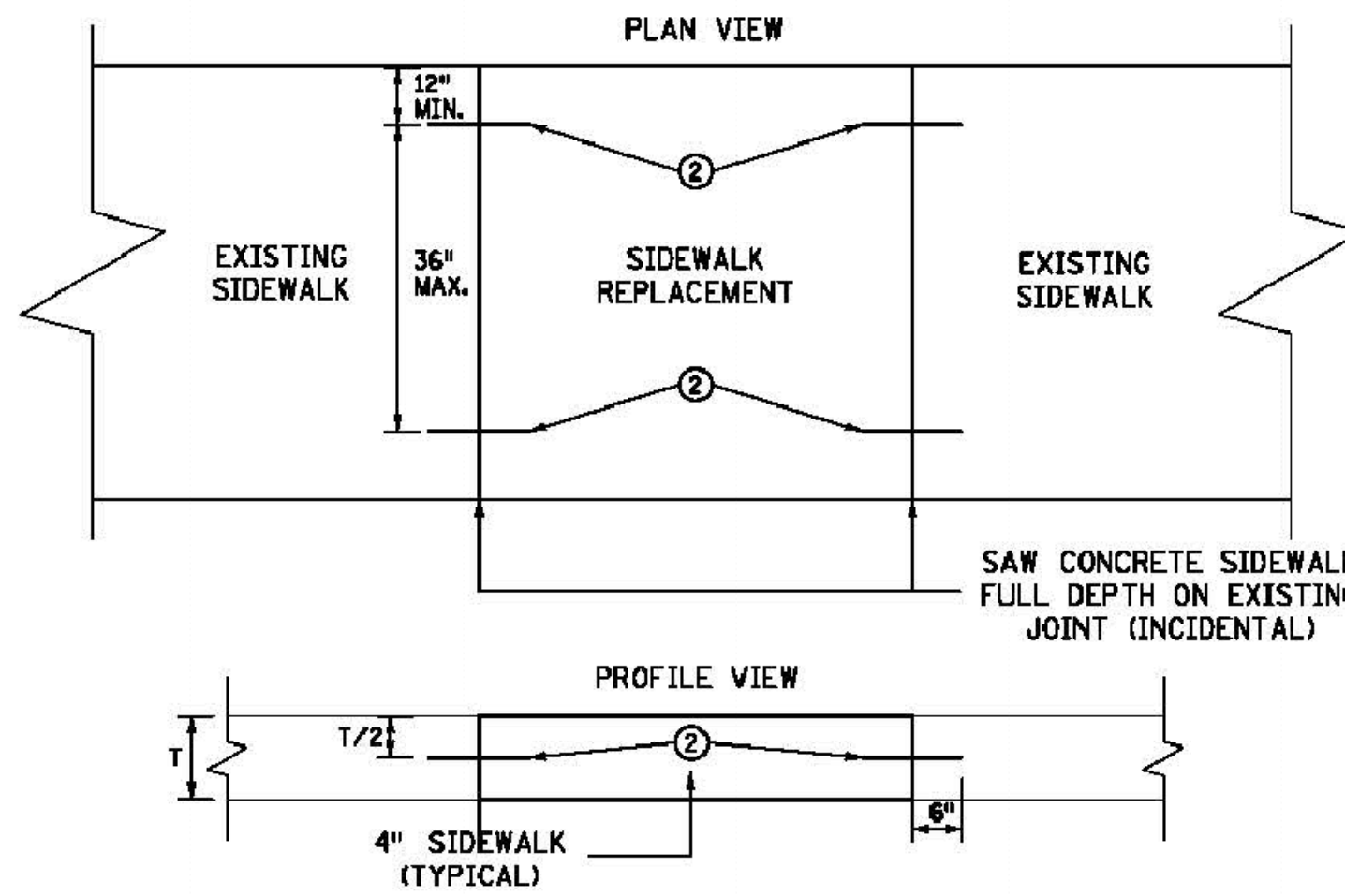

OPTIONAL SIDEWALK REINFORCEMENT

SIDEWALK REINFORCEMENT TO BE USED ONLY WHEN SPECIFIED IN THE PLAN.

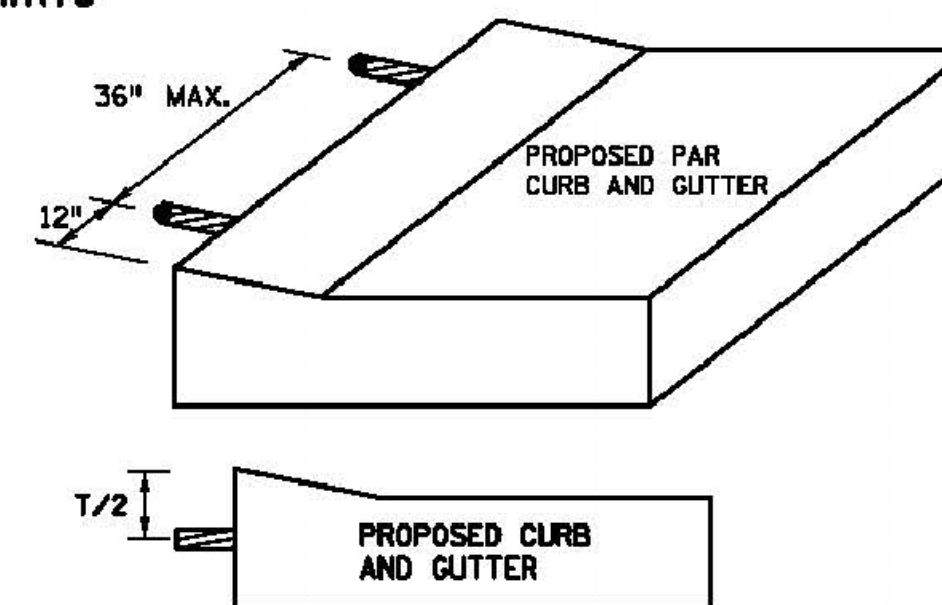

OPTIONAL CURB LINE REINFORCEMENT DETAILS

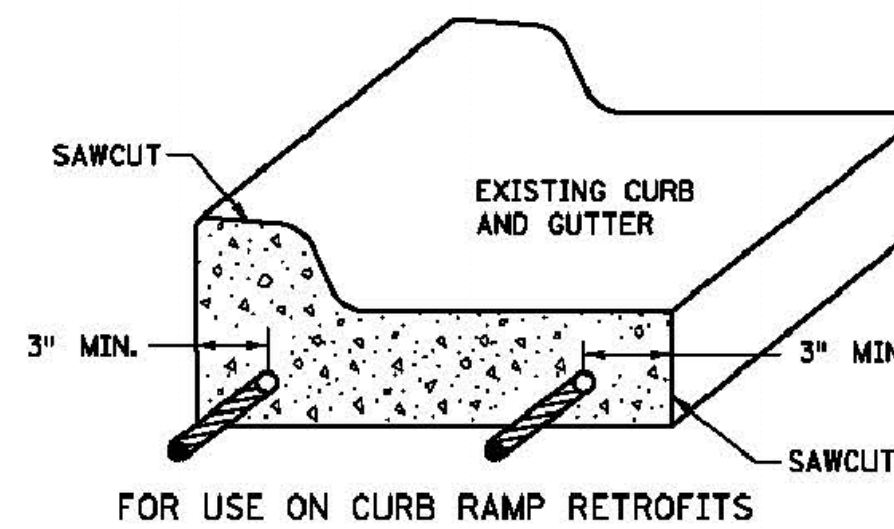

CURB AND GUTTER REINFORCEMENT

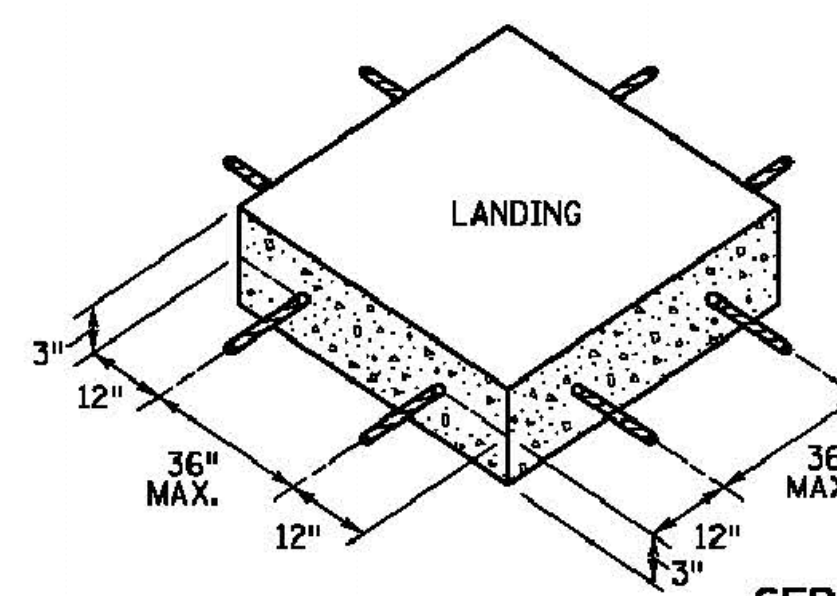

SEPARATE LANDING POUR REINFORCEMENT

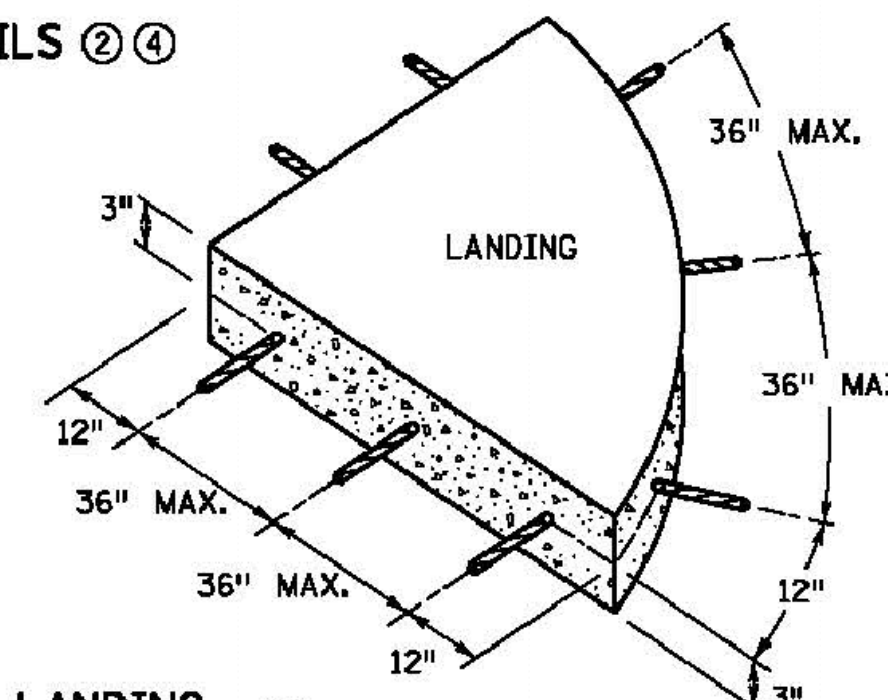

"TABLING" OF CROSSWALKS MEANS MAINTAINING LESS THAN 2% CROSS SLOPE WITHIN A CROSSWALK, IS REQUIRED WHEN A ROADWAY IS IN A STOP OR YIELD CONDITION AND THE PROJECT SCOPE ALLOWS.

RECONSTRUCTION PROJECTS: ON FULL PAVEMENT REPLACEMENT PROJECTS "TABLING" OF ENTIRE CROSSWALK SHALL OCCUR WHEN FEASIBLE.

MILL & OVERLAY PROJECTS: "TABLING" OF FLOW LINES, IN FRONT OF THE PEDESTRIAN RAMP, IS REQUIRED WHEN THE EXISTING FLOW LINE IS GREATER THAN 2% WARPING OF THE BITUMINOUS PAVEMENT CAN NOT EXTEND INTO THE THROUGH LANE. TABLE THE FLOW LINE TO 2% OR AS MUCH AS POSSIBLE WHILE ADHERING TO THE FOLLOWING CRITERIA:

- 1) 1.0% MIN. CROSS-SLOPE OF THE ROAD
- 2) 5.0% MAX. CROSS-SLOPE OF THE ROAD
- 3) "TABLE" FLOW LINE UP TO 4% CHANGE FROM EXISTING SLOPE IN FRONT OF PEDESTRIAN RAMP
- 4) UP TO 2% CHANGE IN FLOW LINE FROM EXISTING SLOPE BEYOND THE PEDESTRIAN CURB RAMP

STAND-ALONE ADA RETROFITS: FOLLOW MILL & OVERLAY CRITERIA ABOVE HOWEVER ALL PAVEMENT WARPING IS DONE WITH BITUMINOUS PATCHING ON BITUMINOUS ROADWAYS AND FULL-DEPTH APRON REPLACEMENT ON CONCRETE ROADWAYS.

RAISING OF CURB LINES SHOULD OCCUR IN VERTICALLY CONSTRAINED AREAS. RAISE THE CURB LINES ENOUGH TO ALLOW COMPLIANT RAMPS OR AS MUCH AS POSSIBLE WHILE ADHERING TO THE FOLLOWING CRITERIA:

- 1) 1.0% MIN. AND 5.0% MAXIMUM CROSS-SLOPE OF THE ROAD
- 2) 1.0% MIN. FLOW LINE (ON EITHER SIDE OF PEDESTRIAN RAMP) TO MAINTAIN POSITIVE DRAINAGE
- 3) 5.0% RECOMMENDED MAX. FLOW LINE
- 4) LONGITUDINAL THROUGH LANE ROADWAY TAPERS SHOULD BE 1" VERTICAL PER 15' HORIZONTAL

NOTES:

- ① TO ENSURE RAMPS AND LANDINGS ARE PROPERLY CONSTRUCTED, ALL INITIAL LANDINGS AT A TOP OF A RAMPED SURFACE (RUNNING SLOPE GREATER THAN 2%) SHALL BE FORMED AND PLACED SEPARATELY IN AN INDEPENDENT CONCRETE POUR. FOLLOW SIDEWALK REINFORCEMENT DETAILS ON THIS SHEET FOR ALL SEPARATELY POURED INITIAL LANDINGS.
- ② DRILL AND GROUT NO. 4 12" LONG REINFORCEMENT BARS AT 36" MAXIMUM CENTER TO CENTER (EPOXY COATED). BARS TO BE ADJUSTED TO MATCH RAMP GRADE.
- ③ DRILL AND GROUT 2 - NO. 4 X 12" LONG REINFORCEMENT BARS (EPOXY COATED). REINFORCEMENT REQUIRED FOR ALL CONSTRUCTION JOINTS WITHIN RADIUS.
- ④ THIS OPTIONAL CURB LINE REINFORCEMENT DETAIL SHOULD ONLY BE USED ON BITUMINOUS ROADWAYS WHEN SPECIFIED IN THE PLAN.
- ⑤ 1/2 IN. PREFORMED JOINT FILLER MATERIAL PER MNDOT SPEC. 3702.

REVISION:

APPROVED: JANUARY 23, 2017

OPERATIONS ENGINEER



STANDARD PLAN 5-297.250 6 OF 6

APPROVED: 1-23-2017

REVISOR:

STATE DESIGN ENGINEER

PEDESTRIAN CURB RAMP DETAILS

STATE PROJ. NO. (T.H.) SHEET NO. OF SHEETS

DESIGNED	REVISOR	BY	DATE
DJT			

LATEST REVISION: 1-28-2019

Prepared For:
Andy Baartman
1489 Hay Creek Valley Rd
Red Wing, MN 55066

FILE NO.: 07124 Baartman