

PROJECT MANUAL SPECIFICATIONS

for the Proposed

Bottineau Ridge III - 50 Unit Apartment

**11700 80th Avenue North
Maple Grove, MN 55369**

ARCHITECT

COLE GROUP ARCHITECTS, LLC
216 Park Avenue South Suite 102
St. Cloud, MN 56301
(320) 654-6570 office
Norm Cole / David Majchrzak
norm@colegrouparchitects.com
david@colegrouparchitects.com

STRUCTURAL ENGINEER

SANDMAN STRUCTURAL ENGINEERING
1587 30th Ave S
Moorhead, MN 56560
(218) 227-0022 office
Nathan Hoffman, P.E.

CIVIL ENGINEER

LOUCKS
7200 Hemlock Lane Suite 300
Maple Grove, MN 55369
(763) 424-5505
Clark Lohr

GEO-TECHNICAL ENGINEER

BRAUN-INTERTEC CORP.
11001 Hampshire Avenue S
Minneapolis, MN 55438
(952) 995-2000 Office
Bradley McCarter

INTERIOR DESIGNER/FF&E

DUFFY DEVELOPMENT COMPANY

DEVELOPER

DUFFY DEVELOPMENT COMPANY
12708 Wayzata Blvd Suite 400
Minnetonka, MN 55305
(952) 544-6769
Jeff Von Feldt

February 22, 2021

Project # 19027
100% Submittal

GENERAL CONTRACTOR

LUMBER ONE, AVON INC.
101 2ND Street NW
Avon, MN 56310
(320) 356-7342 office (320) 980-4825 cell
Lyle Beumer Project/Operations Manager
lbeumer@lumber-one.com

ELECTRICAL ENGINEER (Performance Outline)

LINDELL ENGINEERING
3411 Kilmer Lane North
Minneapolis, MN 55441
(763) 354-1098
Jay Jagerson

MECHANICAL ENGINEER (Performance Outline)

LINDELL ENGINEERING
3411 Kilmer Lane North
Minneapolis, MN 55441
(763) 542-9163
Tim Johnson

FIRE ALARM & SUPPRESSION

DESIGN-BUILD

PROFESSIONAL CERTIFICATION

ARCHITECT

I hereby certify that this specification was prepared by me or under my direct supervision, and that I am a duly Registered Architect under the laws of the State of MINNESOTA.

Norm Cole 22288 2-22-21 100%

ARCHITECT; Norm Cole	REGISTRATION NO.	DATE
----------------------	------------------	------

STRUCTURAL ENGINEER

I hereby certify that this specification was prepared by me or under my direct supervision, and that I am a duly Registered Structural Engineer under the laws of the State of MINNESOTA.

Kurt Sandman 43486 2-22-21 100%

STRUCTURAL ENGINEER; Sandman Structural; Kurt Sandman	REGISTRATION NO.	DATE
--	------------------	------

CIVIL ENGINEER

I hereby certify that this specification was prepared by me or under my direct supervision, and that I am a duly Registered Civil Engineer under the laws of the State of MINNESOTA.

Michael J. St. Martin 24440 2-22-21 100%

CIVIL ENGINEER; Michael J. St. Martin	REGISTRATION NO.	DATE
--	------------------	------

LANDSCAPE ARCHITECT

I hereby certify that this specification was prepared by me or under my direct supervision, and that I am a duly Registered Landscape Architect under the laws of the State of MINNESOTA.

Gregory A. Johnson 24610 2-22-21 100%

LANDSCAPE ARCHITECT; Gregory A. Johnson	REGISTRATION NO.	DATE
--	------------------	------

**Bottineau Ridge III – 50 Unit Apartment
Specifications Table of Contents**

Division	Section and Title	Pages
00	<u>BIDDING & CONTRACT REQUIREMENTS</u>	
000105	Title Page and Certification	2
000110	Table of Contents	3
000115	Index to Drawings	3
001113	Advertisement/Invitation to Bid and Bid Form	2
002113	Instructions to Bidders	9
002600	Procurement Substitution Procedures	2
003100	Existing Project Information	1
004100	Bid Form	3
004313	Bid Security	1
005200	Contracting Forms	2
006113	Performance & Labor & Material Payment Bonds	2
006216	Certificate of Insurance	2
006600	Geotechnical Report Geo-technical Evaluation provided by Braun Intertec Corp to Duffy Development, attached. Report No. B2008300, dated 11-10-20	23
007200	General Conditions MHFA Intended Methods Worksheet – Green Building Requirements AIA Document A101 Standard Form of Agreement between Owner and Contractor MHFA – Supplemental to General Conditions of Agreement between Owner/Contractor MHFA – Equal Employment Opportunity Statement MHFA – MN Housing Multifamily Insurance Requirements MHFA – Form #214 MHFA – Assignment of Construction Contract MHFA – Performance Bond Form MHFA – Payment Bond Form HUD FORMS – 5369A, 5370 and other applicable HUD Documents as specified in Section 002113, Item 25	
007300	Supplementary General Conditions	
007380	Special Conditions – Liquidated Damages	
009113	Addenda and Proposal Requests Addendum#1 dated 1-27-21 and PR#1 dated 2-22-21	
01	<u>GENERAL REQUIREMENTS</u>	
Section 011100	Summary of Work _____	011000 _____ 1
Section 011200	Alteration Project Procedures _____	011200 _____ 1
Section 012100	Allowances _____	012100 _____ 1
Section 012300	Alternates _____	012300 _____ 2
Section 012600	Contract Considerations _____	012600 _____ 1
Section 012700	Applications for Payment _____	012700 _____ 1
Section 013113	Project Management and Coordination _____	013113 _____ 1
Section 013119	Project Meetings _____	013119 _____ 1
Section 013300	Submittals _____	013300 _____ 1
Section 014219	Reference Standards _____	014219 _____ 1-4
Section 014516	Quality Control _____	014516 _____ 1
Section 014533	Special Structural Testing & Inspections Schedule _____	014533 _____ 1-5
Section 015000	Temporary Facilities & Controls _____	015000 _____ 1-2
Section 016000	Product Requirements _____	016000 _____ 1
Section 017329	Cutting & Patching _____	017329 _____ 1-2
Section 017419	Waste Management Plan _____	017419 _____ 1
Section 017800	Project Close-out _____	017800 _____ 1-2

**Bottineau Ridge III – 50 Unit Apartment
Specifications Table of Contents**

Division	Section and Title	Pages
02	SITE WORK/CIVIL/FENCING	
	020000 <i>Civil Specifications per Loucks Engineering</i>	
03	CONCRETE	
	031000 Concrete Formwork _____	031000-----1-3
	031510 Concrete Anchoring _____	031510-----1-3
	032000 Concrete Reinforcement _____	032000-----1-2
	033000 Cast-in-place Concrete _____	033000-----1-5
	033505 Gypsum Self-Leveling Underlayment _____	033505-----1
	034100 Precast Structural Concrete _____	034100 -----2
	035400 Cast Underlayment _____	035400-----2
	036000 Foundation Insulation _____	036000-----1
04	MASONRY	
	042000 Unit Masonry _____	042000-----1-7
	047200 Cast Stone Masonry _____	047200 -----1-3
05	STEEL-METALS	
	051000 Structural Steel _____	051000-----1-2
	055000 Metal Fabrications/Aluminum Railing _____	055000-----1-4
	055913 Metal Balconies _____	055913 -----1-4
06	CARPENTRY	
	061000 Rough Carpentry & Framing _____	061000-----1-6
	061700 Trusses _____	061700-----1-4
	062000 Finish Carpentry _____	062000-----1-2
	066200 Cast Plastic Fabrications _____	066200-----1
	066500 Decorative Column Covers _____	066500-----1-5
07	THERMAL & MOISTURE PROTECTION	
	071000 Sheet Waterproofing _____	071000-----1-3
	071100 Vapor Barrier _____	071100-----1
	071500 Caulking _____	071500-----1
	072100 Insulation _____	072100-----1-5
	072500 Air Infiltration _____	072500-----1
	072700 Fire stopping _____	072700-----1-2
	073000 Roofing Laminated Shingles _____	073000-----1-4
	074000 Siding _____	074000-----1-2
	074650 Prefinished Metal Fascia and Vented Soffits _____	074650-----1-2
	075300 Elastomeric Membrane Roofing _____	075300-----1-3
	076200 Sheet Metal Flashing and Trim _____	076200-----1
	078400 Firestopping _____	078400-----1-2
	079000 Joint Sealers _____	079000-----1-2

**Bottineau Ridge III – 50 Unit
Specifications Table of Contents**

Division	Section and Title	Page
<u>080000-DOORS and WINDOWS</u>		
	081100 Prefinished Steel Doors and Window Frames _____	081100-----1-4
	081300 Standard Steel Doors _____	081300-----1-3
	081400 Interior Wood Doors _____	081400-----1-3
	081450 Pre-hung Wood Doors _____	081450-----1-3
	083100 Access Doors & Panels _____	083100-----1
	083600 Power Operated Overhead Doors _____	083600-----1-2
	084313 Aluminum Framed Storefront Doors _____	084313-----1-2
	085300 Vinyl Windows _____	085300-----1-2
087000 - 087100	Finish Hardware, Weather stripping, Thresholds _____	087000-----1-11
	088000 Glazing _____	088000-----1-2
<u>090000 FINISHES</u>		
090000	Verify ALL FINAL product selections with Interior Designer/Duffy Development _____	090000----- 1-8
092500	Gypsum Board Systems _____	092500----- 1-2
093000	Tiling _____	093000----- 1-4
095100	Suspended Acoustical Ceilings _____	095100-----1-2
096500	Resilient Flooring _____	096500----- 1-2
096570	Composite Decking _____	096570----- 1-4
096880	Carpeting _____	096880-----1-2
099000	Painting _____	099000----- 1-3
<u>100000 SPECIALTIES</u>		
101100	Visual Display Boards _____	101100-----1-2
101400	Identifying Devices _____	101400-----1
102600	Corner Guards on Common Area Walls _____	102600----- 1-3
103100	Gas Fireplaces _____	103100----- 1
105220	Fire Extinguishers and Cabinets _____	105220-----1
105513	Mailboxes _____	105513-----1
105700	Wire Shelving _____	105700-----1
108000	Bath Accessories _____	108000-----1-2
109900	Miscellaneous Specialties _____	109900-----1
<u>110000 EQUIPMENT</u>		
112000	Residential Appliances – Energy Star _____	112000-----1-45
<u>120000 FURNISHINGS</u>		
122100	Horizontal Louver Blinds _____	122100-----1
122111	Vertical Blinds _____	122111-----1
123500	Residential Casework _____	123500-----1-2
123600	Countertops _____	123600-----1-2
<u>140000 CONVEYING DEVICES</u>		
142000	Elevator _____	142000-----1-6
14918	Trash Chutes _____	149180----- 1-4

Bottineau Ridge III – 50 Unit Specifications Table of Contents

Division	Section and Title	Page
----------	-------------------	------

150000 MECHANICAL/PLUMBING

150000 - 152700	Mechanical/Plumbing PERFORMANCE SPECS ONLY by LINDELL (DESIGN-BUILD)----by Lindell Engineering
-----------------	--

160000 ELECTRICAL

160000 - 160090	Electrical Specs PERFORMANCE SPECS ONLY by LINDELL (DESIGN-BUILD)-----by Lindell Engineering
-----------------	--

31000 EARTHWORK **LOUCKS- CIVIL Engineering**

015713	EROSION and SEDIMENT CONTROL
024113	SELECTIVE DEMOLITION
311010	SITE CLEARING
312200	EARTHWORK
312219	FINISH GRADING
312300	EXCAVATION and FILL
315000	EXCAVATION SUPPORT and PROTECTION

320000 **SITE IMPROVEMENTS**

321216	ASPHALT PAVING
321313	CEMENT CONCRETE PAVING
328400	IRRIGATION
329200	TURF and GRASSES
329300	EXTERIOR PLANTS

330000 **UTILITIES**

330600	UTILITY MATERIALS
331100	WATER DISTRIBUTION
334100	STORM DRAINAGE

PROJECT:	Bottineau Ridge Phase III One (1) 50 Unit Apartment Building 80 th Avenue North Maple Grove, MN	1) Miller Architects and Builders. 3335 West St. Germain Street St. Cloud, MN 56301 sales@millerab.com (320) 251-4109
ARCHITECT:	Cole Group Architects 216 Park Avenue South Suite 102 St. Cloud, MN 56301 ATTN: Norm Cole	2) Lumber One (Avon) P.O. Box 7 101 2nd Street NW Avon, MN 56310 320-356-7342 lbeumer@lumber-one.com
GENERAL CONTRACTOR:	3 Selected →	
DEVELOPER:	DUFFY DEVELOPMENT COMPANY 12708 Wayzata Blvd Suite 400 Minnetonka, MN 55305 (952) 544-6769 Attn: Jeff Von Feldt jvonfeldt@duffydevelopment.com	3) CBS Construction 11124 Zealand Ave. North Champlin, MN 55316 763-569-4020 info@cbsconstruct.com

BIDS DUE: February 2, 2021 12 pm Noon local time - submitted to General Contractor's Office by email.

PLACE DUE: Bids may be received as follows:

- 1) Electronically at the offices of General Contractor
- 2) **G.C. address; bidder to get address from G.C. requesting their bid.**

If bid is mailed, it must arrive to the G.C. by Bid due dates and times provided above.

Copies of the Plans and Specifications will be emailed to G.C.'s invited to bid via a Dropbox link. It is the responsibility of the subcontractor to submit their bids to the G.C. they received an invite from by February 2, 2021.

QUESTIONS: Questions and clarifications may be directed to the Architect only.

TYPE OF BIDDING, AND CLASSES OF WORK: The General Contractor will accept bids from subcontractors for furnishing work and materials for the construction of Bottineau Ridge III to be located in Maple Grove, MN, a project including all divisions will be received by G.C. at the above mentioned time and place in accordance with plans and specifications prepared by Cole Group Architects.

AVAILABILITY OF DOCUMENTS: Drawings & Specifications will be available for download via an online Dropbox link.

OPEN HOUSE: There will be an open house for Subs/Contractors to tour the existing facility, located at 80th Avenue North Maple Grove, MN on 1/21/21 from 9:30 am to 12:30pm.

OPENING OF BIDS: Bids will be opened privately by the Owner.

Bids may not be withdrawn for thirty (30) days after the scheduled closing time for receiving bids. The Owner reserves the right to reject any or all bids and waive any irregularities in bids without explanation.

The following instructions apply to all Contract Divisions. Failure to comply may result in the rejection of bid(s). Also review/refer to Advertisement for Bids, General Conditions, and Supplemental Conditions.

1. BIDS:

Lump Sum bids will be received by the Owner at the time and place designated in the Advertisement to Bid and will be opened at that time.

2. DOCUMENTS for BIDDING:

Complete sets of Bidding Documents may be obtained in the manner described in the Advertisement to bid. Complete sets of documents shall be used to prepare Bids; neither the Owner nor the Architect assume any responsibility for errors or misinterpretations resulting from the use of incomplete or outdated sets of bidding Documents.

3. QUALIFICATIONS of BIDDERS:

To demonstrate qualifications to perform the Work, Bidders must be prepared to submit requested written evidence to the G.C., prior to award of contract which, is deemed necessary to determine the ability of the Bidder to perform the Work.

4. EXAMINATION of Bidding Documents:

Prior to submitting their bid, each Bidder must examine the Bidding Documents thoroughly, visit the site to familiarize themselves with local conditions that exist and may in any manner affect cost, progress or performance of the Work, and familiarize themselves with federal, state and local laws, ordinances, rules and regulations that may affect cost, progress or performance of the Work, and carefully study and correlate Bidder's observation with the Bidding Documents.

5. INTERPRETATION:

Any Bidder/Contractor that is in doubt as to the meaning of any part of the Drawings, Specifications, or other Bidding documents or finds discrepancies in or omissions from the Drawings or Specifications must submit a written request for interpretation, clarification or correction thereof to the Architect at least seven (7) working days prior to the Bid Due Date. The Contractor shall promptly notify the Engineer of inconsistencies, errors and omissions found in the Drawings and Specifications prior to bid date.

Any interpretation, clarification or correction of the documents will be made only by Addendum issued by the Architect. A copy of the addendum will be emailed to each person receiving a complete set of Bidding Documents.

6. APPROVAL of SUBSTITUTIONS:

Requests for approval of substitutions must be made in writing to the Architect and must be received at least seven (7) working days prior to the bid due date. The Architect will issue a written Addendum listing the products approved prior to the bid due date. The Contractor shall not furnish any substitute material, product, or equipment not so approved. If rejection of any such unapproved substitution causes a change in the supplier proposed, or removal of work in place, there shall be no increase in the Contract Sum allowed due to any increase in cost created by such a change or removal. Items receiving prior approval will be subject to final approval when the Shop Drawing submittals are reviewed.

The Contractor shall be responsible for fit and clearances of substituted items and for making any modifications in his Work or the work of other Contractors necessitated by the use of any substitution, without cost to the Owner or other affected Contractor.

7. ADDENDA:

Any addenda issued during the time of bidding or forming of the Bidding Documents shall become a part of the Contract. Receipt of each addendum shall be acknowledged on the Bid Form.

8. TAXES, PERMITS, & FEES:

Each Bidder shall include in their Bid, the amount which is estimated will be payable by the successful Bidder on account of taxes imposed by any taxing authority upon the sale, purchase or use of materials, supplies or equipment incorporated in the project. The taxes of the foregoing description shall be paid by the Bidder who is awarded the Contract for the construction of the project. All building permits, plan check fees, State plumbing fees, and State surcharges will be paid by the Contractor. Fees for special local, state, or federal inspections relating to mechanical, electrical, conveying systems, and similar installations shall be paid by the Contractor or Sub-contractor to which such inspections apply.

9. BIDDER INTERESTED IN MORE THAN ONE BID:

No persons, firm or corporation shall be allowed to make, file or be interested in more than one bid for the same work, unless alternate bids are called for. A person, firm, or corporation who has submitted a sub-bid to a Bidder, or who has quoted prices on materials to a Bidder, is not hereby disqualified from submitting a sub-bid or quoting prices to other Bidders.

10. BID FORM:

Each Bid shall be made on a form that has been prepared by the Architect and which is included as one of the Bidding Documents. Bid Form must be fully complete and executed when submitted. Pencil bids or illegible bids may be cause for rejection. Only one copy of the bid form is required.

11. BID MODIFICATIONS:

The Bid Form may not contain any modifications of the work to be done. Alternate Bids will not be considered unless specified on the Bid. A conditional or qualified Bid will not be accepted.

12. BID SECURITY:

Bid Bonds are not required by Owner.

13. ALTERNATES:

Bidder shall quote all Alternates as described in the Bidding Documents. The Owner reserves the right to reject any or all alternates or to accept any alternates in any order.

14. BID SIGNING:

Bids which are not signed by individual making them, shall have attached a Power-of-Attorney evidencing authority to sign the bid in the name of the person for whom it is signed. Bids which are signed for a co-partnership shall be signed by one of the co-partners or by an attorney-in-fact. If signed by an attorney-in-fact, there shall be attached to the bid a Power-of-Attorney evidencing authority to sign the bid.

Bids which are signed for a corporation shall have the correct corporation name thereof shown and the signature of the president or other authorized officer of the corporation. If such bid is manually signed by an officer other than the president of the corporation, a certified copy of a resolution of the board of directors evidencing the authority of such official to sign the bid shall be attached to the bid.

15. BID SUBMITTAL:

Refer to Section 001113 for information on submitting Bids for "Bottineau Ridge III Apartment".

16. BID OPENING: Bids will be opened as set forth in the Advertisement for Bids.

17. BIDS TO REMAIN OPEN:

All bids shall remain open for the number of days designated in the Advertisement for Bids but the Owner may, in his sole discretion, release any Bid and return the Bid Security prior to that date.

18. BID EVALUATION:

The Owner reserves the right to waive any informalities or minor defects and to reject any and all Bids. In evaluating Bids, the Owner shall consider the qualification of the Bidders; whether or not Bids comply with the prescribed requirements; and alternates, if requested in the Bid forms. The Owner may conduct such investigations as he deems necessary to assist in the evaluation of any Bid and to establish the responsibility, qualifications and final ability to the Bidder, proposed subcontractors and other persons and organizations to do the work. The low bidder shall supply the names and addresses of major material suppliers and sub-contractors when required to do so by the Owner. If a Contract is to be awarded, it will be awarded to the lowest Bidder whose evaluation by the Owner indicated that the award will be in the best interest of the Owner. Should there be reasons why the Contractor cannot be awarded within the specified time for bids to remain open, the time may be extended by mutual agreement between the Owner and the Bidder.

19. NOTICE OF AWARD:

If a Bid is acceptable by the Owner, a Notice of Award will be issued by the Owner to the successful Bidder. This Bidder shall be required to execute the Agreement and obtain the Performance Bond, Labor and Material, Payment Bond and Project Insurance within ten (10) calendar days from the date when Notice of Award is delivered to the Bidder. The Notice of Award shall be accompanied by the necessary Agreement, Bond Forms and Insurance Forms. In case of failure of the Bidder to execute the Agreement, the Owner may consider the Bidder in default. The Owner within ten (10) days of receipt of acceptable Performance Bond, Payment Bond, Project Insurance Certificate and Agreement signed by the party to whom the Contract was awarded will sign the Agreement and return to such party an executed duplicate of the Agreement. Should the Owner not execute the Agreement within such period, the Bidder may by WRITTEN NOTICE withdraw the signed Agreement. Such notice of withdrawal shall be effective upon receipt of the notice by the Owner.

20. FORM OF AGREEMENT:

Contract will be executed on AIA Document A101. "Standard Form of Agreement between Owner and Contractor". MHFA Documents listed in General Conditions.

21. PERFORMANCE AND LABOR & MATERIALS BONDS:

A Performance Bond and a Labor and Materials Payment Bond each in the amount of 100 percent of the contract price, with a corporate surety approved by the Owner, will be required for the faithful performance of the contract. Attorneys-in-fact who sign Labor and Material Payment Bonds and Performance Bonds must file with each Bond a certified and effective dated copy of their Power-of-Attorney. Bonds shall be submitted on AIA Documents A311, "Performance Bond & Labor & Material Payment Bond". MHFA Documents listed in General Conditions.

22. PROJECT INSURANCE:

The Contractor shall purchase and maintain insurance for this project in accordance with the General Conditions and Supplementary Conditions. The Contractor shall file an acceptable Certificate of Insurance and insurance policy with the Owner prior to the Owner executing and returning the signed Agreement to the Contractor. Certificate of Insurance shall be Accord Form 25-S. MHFA Documents listed in General Conditions.

23. NOTICE TO PROCEED:

The Notice to Proceed shall be issued as per the Contract between the Owner and General Contractor.

24. TIME OF COMPLETION

- A. Bidder agrees to commence work on or before a date to be specified in a written Notice to Proceed by the Owner and to fully complete the Construction Work as outlined in the project documents and as based on project alternates taken.
- B. Anticipated Start Date is Spring 2021.
- C. Date of Substantial Completion: Contractor shall indicate their proposed Substantial Completion date on their Bid Form.

25. CONTRACTOR REQUIREMENTS:

Abide by appropriate Federal and State labor laws in respect to contracted employees and subcontractors. Conduct business in an ethical manner reflecting honesty, craftsmanship, trustworthiness, integrity and respect of human values.

Respect Owner's personnel policies and practices.

Adhere to all applicable environmental code within Owner's environment including grounds, storage and offices.

Employ individuals who are not at undue risk of physical harm and are trained in safety measures and physical demands of the job functions.

Adhere to Owner's security policies and individual identification practices.

Individual dress code will include attire that is neat, identifies name of individual (name tag acceptable) and company and assures that no article of clothing is worn in a way that may cause harm to themselves or others.

Follow plans and specs as provided by the Architect of record. Changes are to be approved by the Architect prior to work being done. Work performed prior to written approval will not be compensated.

Work site is to be kept clean and orderly on a daily basis to prevent any hazardous conditions or harm to others.

Appropriate required insurances will be provided to Architect within (2) two days of Notice of Award prior to commencing and work. Abide by all safety requirements.

26. DOCUMENTS:

These documents (plans and specifications) are provided as a guide to the Contractor and do not contain all information required to construct the project. This project, however, includes all materials, labor, coordination and design required for a finished, fully operational, code compliant project.

No additional money will be granted to a contractor for any such work required for said finished, fully operational, code compliant project.

- A. THIS PROJECT IS PARTICIPATING IN IMPLEMENTING MINNESOTA HOUSING FINANCE AGENCY SUSTAINABLE HOUSING POLICIES, most notably the MN Overlay to the Green Communities Criteria, which can be referenced at www.greencommunitiesonline.org/minnesota. These include the required criteria as stated below as a minimum acceptable standard prior to approval.**

- B. CONTRACT CLAUSES**

All contracts should identify the contract pricing arrangement as well as other pertinent terms and conditions. Additionally, the forms HUD-5369, 5369-A, 5369-B, 5369, 5370, 5370-C, and 51915-A , which contain all HUD-required clauses and certifications for contracts of more than \$100,000, as well as any forms/clauses as required by HUD for small purchases, shall be used in all corresponding solicitations and contracts issued by this Authority.

27. LIQUIDATED DAMAGES: Refer to Section 073800

28. BUILDING PERMIT

A. The General Contractor shall include the cost of the building permit in their bid.

29. BUILDER'S RISK INSURANCE

A. The Owner will provide Builder's Risk Insurance.

B. See Section 007300 - Supplementary Conditions/requirements.

30. STORING MATERIALS OFF-SITE

A. If it is desired by the Contractor to order and store materials off-site, there shall be prior agreement to any arrangement by the Owner and Architect before ordering or Application for Payment. Evidence shall be furnished to the Owner and Architect that the materials have been ordered, delivered and paid for. A Certificate of Insurance for materials stored off-site shall accompany other required information at the time of the Application for Payment. The location of the stored materials shall be acceptable to the Owner.

RECEIPT AND WAIVER OF MECHANIC'S LIEN

1. THE UNDERSIGNED ACKNOWLEDGES RECEIPT of a current payment of \$_____ from _____. This payment, when added to all prior payments on this project equals a total sum paid to date of \$_____. This total sum represents payment in full, except for unpaid retention of \$_____, for all labor and materials furnished to the property described below by the undersigned through (draw date) , 200 .

2. AS CONSIDERATION FOR SUCH PAYMENT, the undersigned does hereby waive, release and relinquish any and all right to claim a lien on the following described property for work done or material furnished prior to the above-referenced date other than for the unpaid retention described above:

Property
Address

3. INCLUDING THE RETENTION DESCRIBED ABOVE and all signed change orders, the unpaid balance of our contract is \$_____.

Company _____

Address _____

By _____
(Signature)

Title _____
(Officer of the Company)

Phone No. _____

PART 1 GENERAL

1.01 SUMMARY

A. Section Includes

1. Requirements for submitting substitution requests for materials, products, equipment and methods of construction from those required by the Procurement Documents, during the procurement phase and prior to execution of the Owner/Contractor Agreement.

1.02 SUBSTITUTIONS (DURING THE PROCUREMENT/BIDDING PHASE)

A. The technical specification sections may have several materials, products, equipment and methods of construction specified under the same heading. Selection of a specified materials, products, equipment and methods of construction shall be at the option of the Bidder. Where materials, products, equipment and methods of construction are specified accompanied with the phrase "Or Equal", "Approved Substitution", or similar verbiage, the Bidder may submit materials, products, equipment and methods of construction for approval in accordance with the requirements of this Document.

B. No substitution will be considered prior to receipt of Bids unless written request for approval has been received by the Architect (or Construction Manager as applicable) at least seven working days prior to the date for receipt of Bids.

1. Submit each request for substitution on the Architect's "Procurement Substitution Request Form" included at the end of this Section.
2. Submit one materials, products, equipment and methods of construction per request form, either duplicated from the Project Manual or available from the Architect's office.
3. Submittals not accompanied by this form properly filled in and endorsed, will be discarded without review. NO EXCEPTIONS.
4. Where specified materials, products, and equipment are accompanied by a color, pattern or finish selection, requests for substitution shall include an actual sample of the proposed color, pattern or finish for review.
5. Where multiple materials, products or equipment are specified within a single specification section, specifically identify which product you wish to substitute.

C. The burden of proof of the merit of the proposed substitution is upon the proposer. The Architect's decision of approval or rejection of a proposed substitution shall be final.

D. Materials, products, equipment and methods of construction approved by this substitution procedure will be issued in an Addendum.

E. Refer to Section 01 1200 for requests for substitutions after execution of the Owner/Contractor Agreement.

PART 2 PRODUCTS (NOT USED)

PART 3 EXECUTION (NOT USED)

PROCUREMENT SUBSTITUTION REQUEST FORM

TO: Cole Group Architects david@colegrouparchitects.com
Phone: (320) 654-6570

PROJECT: Bottineau Ridge III - 50 Unit Apartment, Maple Grove, Minnesota

Section Number Section Title _____

Specified Product _____

Proposed Substitution _____

All of the following questions must be answered. Incomplete forms will be not be reviewed.

A. The following supporting data is attached:

Drawings Product Data Samples Tests Reports

B. Does the proposed substitution affect dimensions shown on Drawings, or functional clearances?

YES NO

C. Does the proposed substitution change the design or details shown on the Drawings?

YES NO

D. Does the proposed substitution affect other trades?

YES NO

E. Does the proposed substitution affect maintenance service, or source of replacement parts, if applicable?

YES NO

F. Does the proposed guarantee or warranty differ from that specified?

YES NO

G. If you indicated "YES" to Items B, C, D, E or F above, attach a thorough explanation on your company letterhead.

H. If there are other major differences between proposed substitution and specified product, attach a thorough explanation on your company letterhead.

I. The proposed substitution was used within the last 24 months on the following project:

Project Name

Location

Architect Telephone No.

J. The undersigned states that the function, appearance and quality of the substitution item are equivalent or superior to the specified item.

Submitted By:

Signature Firm

Address

Telephone/ Email

Date

For Use By Design Consultant:

Accepted Accepted As Noted Not Accepted Received Too Late

Name Signature _____

Date

Remarks

PART 1 GENERAL

1.01 EXISTING CONDITIONS

A. Certain information relating to existing surface and subsurface conditions and structures is available to bidders and is included for their reference in section 006600

B. Geotechnical Report: Entitled Bottineau Ridge Phase III Apartments, dated 11/10/2020, and prepared by Braun Intertec.

1. This report identifies properties of below grade conditions and offers recommendations for the design of foundations, prepared primarily for the use of Architect/Structural Engineer.
2. This report, by its nature, cannot reveal all conditions that exist on the site. Should subsurface conditions be found to vary substantially from this report, changes in the design and construction of foundations will be made, with resulting credits or expenditures to the Contract Price accruing to Owner.

PART 2 PRODUCTS (NOT USED)

PART 3 EXECUTION (NOT USED)

Signature of General Contractor, attesting to having reviewed the Geo-technical report and existing site conditions. I have familiarized myself with the geo-technical report and am in agreement with the existing conditions of the site:

—

General Contactor

Date

Signature of Excavator, attesting to having reviewed the Geo-technical report and existing site conditions. I have familiarized myself with the geo-technical report and am in agreement with the existing conditions of the site:

Excavator

Date

DATE: _____(month) _____(day), 2021

TO: _____

BIDDER (Individual Name & Company Name): Please type or print

1. The undersigned, having become thoroughly familiar with the terms and conditions of the proposed Contract Documents, each entitled, The Bottineau III Housing, **Project No. 19027, dated January 6, 2021**, as prepared by Cole Group Architects LLC, and with local conditions affecting the performance and costs of the Work at the place where the Work is to be completed as scheduled in strict accordance with the proposed Contract Documents, for the following sum of money:

A. BASE BID : Include upgraded appliances in community room; Refer to Division 09000 Product Guidelines provided by Owner for Phase 2. Also provide 4 extra appliances and A/C units for backup purposes:

The Sum of _____

Dollars (\$) _____

THIS PROJECT IS PARTICIPATING IN IMPLEMENTING MINNESOTA HOUSING FINANCE AGENCY SUSTAINABLE HOUSING POLICIES, most notably the MN Overlay to the Green Communities Criteria, which can be referenced at www.greencommunitiesonline.org/minnesota. These include the required criteria as stated below as a minimum acceptable standard prior to approval.

Coordinate below with MFHA green criteria list:

B. ALTERNATE SCHEDULE: 9 Alternates

~~ALTERNATE #1: (DEDUCT or ADD) Foundation Wall Design _____ Dollars (\$)~~

- ~~• Base Bid: CIP wall with rock block veneer like Phase II~~
- ~~• Alternate 1-a: Precast Wall Panel w/ stencil finish to match PH II~~
- ~~• Alternate 1-b: Block wall w/ rock face finish where it's exposed to match PH II~~

ALTERNATE #2: (DEDUCT or ADD) _____ Dollars (\$)

- Alternate 2: Provide Bike Storage for up to _____ bicycles. Verify bicycle count with Developer. A
- 4-foot Garage storage shelf and bike rack with ladder hooks by TidyGarage (\$76.99 each) or approved equal.

ALTERNATE #3: (DEDUCT or ADD) _____ Dollars (\$)

- Alternate 3: Fencing to secure electrical switchgear. 6'-0" high with 4'-0" gate A

ALTERNATE #4: (DEDUCT or ADD) _____ Dollars (\$)

- Alternate 4: Provide R-21 Spray Foam Insulation in stud wall cavity in lieu of Batt insulation.

ALTERNATE #5: (DEDUCT or ADD) _____ Dollars (\$)

- Alternate 5: Provide Geotextile fabric under all asphalt.

~~**ALTERNATE #6: (DEDUCT or ADD) _____ Dollars (\$)**~~

~~Alternate 6: Furnish and install Slant Fin Fineline 30 fin tube radiation in lieu of Slant Fin HD series as specified for the base bid in section 15170.~~

B. ALTERNATE SCHEDULE: 9 Alternates

BASE BID A _____ Dollars (\$)
 Provide a price to make arrangements with Utility Management Solutions to install individual meters and all equipment required to remotely read hot and cold water meters. All costs for meters, equipment and installation shall be paid for by the mechanical contractor under this alternate.

ALTERNATE #8: (DEDUCT or ADD) _____ Dollars (\$)
 Alternate 8: Provide a ceiling fan in each living room.

ALTERNATE #9: (DEDUCT or ADD) _____ Dollars (\$)
 Alternate 9: Provide fire hydrant at building front.

See Exhibit #1 A

Alternate #10: (DEDUCT or ADD) _____ Dollars (\$)
 Alternate #10: Provide a ceiling feature at the top of two story lobby similar to detail 1/A110. See second floor RCP on sheet A110 to reference location.

Alternate #11: (DEDUCT or ADD) _____ Dollars (\$)
 Alternate #11: Provide microwave above the range hood in lieu of the recessed opening in the pantry. Finish recessed opening like the rest of the pantry.

C. ALLOWANCES SCHEDULE: Coordinate with MHFA Green Communities Criteria.

- C-1. Playground Equipment: Provide a \$25,000.00 allowance** for furnishing and installation of playground equipment.
- C-2. Playground Surfacing: Provide a \$25,000.00 allowance** for furnishing and installation of playground surfacing.
- C-3. Lobby Mural: Provide a \$4,000 allowance** for large mural in lobby; verify design specs with owner.

2. It is understood that the Owner reserves the right to reject any or all bids without explanation, to waive irregularities, and to accept any bid other than the lowest bid, at his discretion. This bid shall remain open and to be withdrawn for a period of 30 days from the date prescribed for its opening.

3. Notice of acceptance, or request for additional information, may be addressed to the undersigned at the address set forth on following page.

4. Successful bidder shall execute the form of Contract, furnish a certificate of insurance and furnish a Performance Bond and Labor and Material Payment Bond each in the amount of the Contract within ten (10) days of receiving written Notice of Award as security for the construction and completion of the Work in accordance with the terms of the Contact, plans and specifications.

5. All Federal, State or Local Taxes are applicable to this work and are included in the Base Bid.

6. Bidder certifies that this proposal is made and submitted without fraud or collusion with any other persons, firm or corporation. Bidder hereby declares that he has carefully examined all Bidding and Contract Documents, Plans and Specifications, and that he has personally inspected the actual location of the work and local sources of supply, has satisfied himself as to all the quantities and conditions, and understands that in signing this Bid he waives all right to plead any misunderstanding regarding the same.

7. Time of Completion.

I (We) do hereby propose to complete all work described in the plans and specifications _____ days after notice to proceed.

8. Refer to spec section 00 73 80 for liquidated damages.

Exhibit #1

UTILITY NOTES

- SEE SHEET C4-1 FOR UTILITY PLAN NOTES

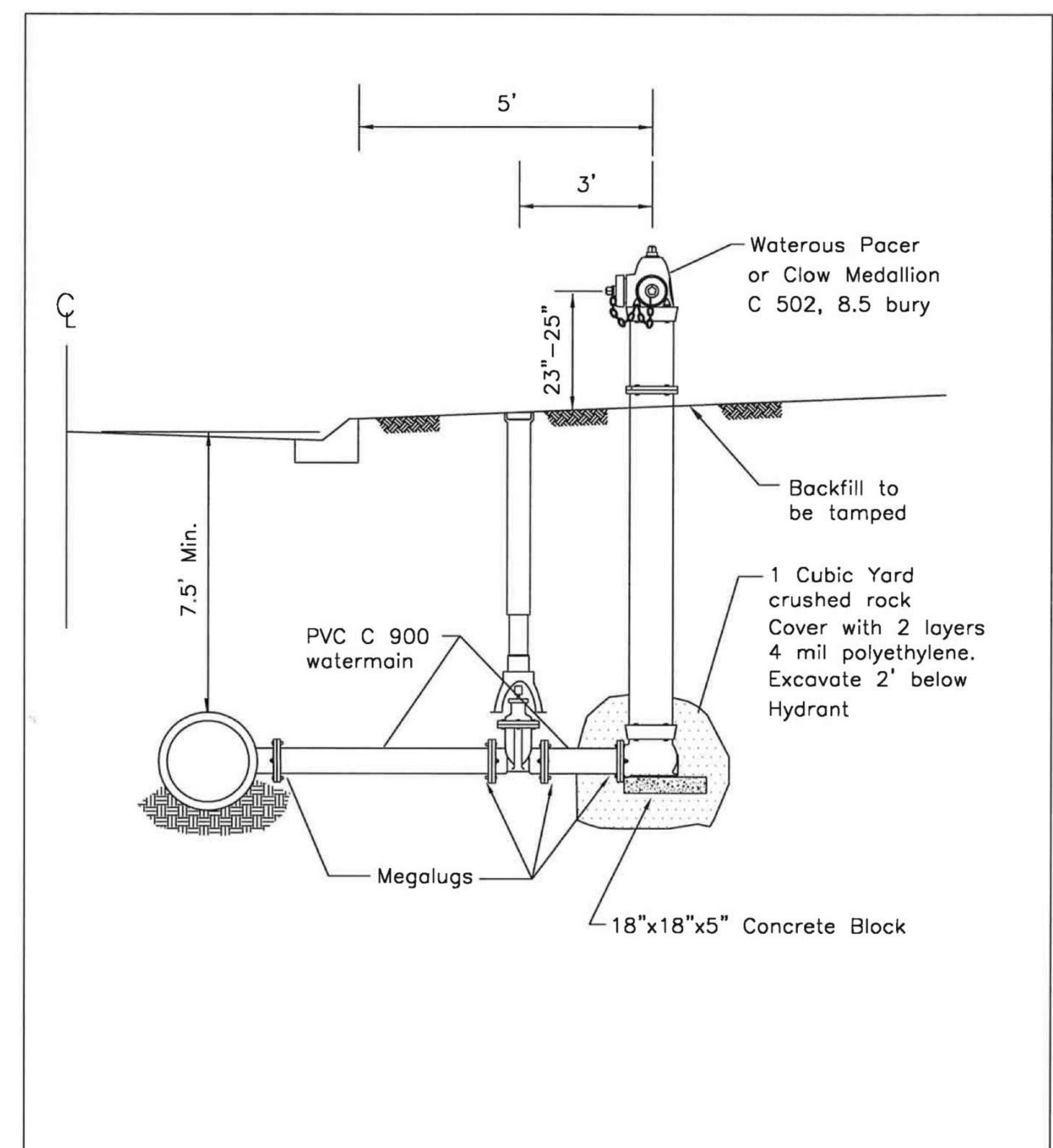

CADD QUALIFICATION

CADD files prepared by the Consultant for this project are instruments of the Consultant's professional services for use solely with respect to this project. These CADD files shall not be used on other projects for additions to this project, or for completion of this project by others without written approval by the Consultant. With the Consultant's approval, others may be permitted to obtain copies of the CADD drawing files for information and reference only. All intentional or unintentional revisions, additions, or deletions to these CADD files shall be made at the full risk of that party making such revisions, additions or deletions and that party shall hold harmless and indemnify the Consultant from any & all responsibilities, claims, and liabilities.

SUBMITTAL/REVISIONS

10/12/20	PUD APPLICATION
11/18/20	CITY COMMENT RESPONSE
01/12/21	FIRE HYD BID ALT

PROFESSIONAL SIGNATURE

I hereby certify that this plan, specification, report was prepared by me or under my direct supervision and that I am a duly Licensed Professional Engineer in the State of Minnesota.

PRELIMINARY
NOT FOR CONSTRUCTION

QUALITY CONTROL

Loucks Project No.	12023F
Project Lead	MJS
Drawn By	GAJ
Checked By	MJS
Review Date	10/09/20

SHEET INDEX

C1-1	BOUNDARY SURVEY
C1-2	TOPOGRAPHIC SURVEY
C1-3	PRELIMINARY PLAN
C1-4	FINAL PLAN
C1-5	SITE DEMOLITION PLAN
C2-1	SITE PLAN
C3-1	GRADING PLAN
C3-2	SWPPP NOTES & DETAILS
C3-3	SWPPP NOTES & DETAILS
C4-1	UTILITY PLAN
C8-1	CIVIL DETAILS
C8-2	CIVIL DETAILS
L1-1	LANDSCAPE PLAN
L2-1	LANDSCAPE DETAILS

**FIRE HYDRANT
UTILITY
PLAN BID
ALTERNATE**

C4-1A

AJH 4/08

NOT TO SCALE

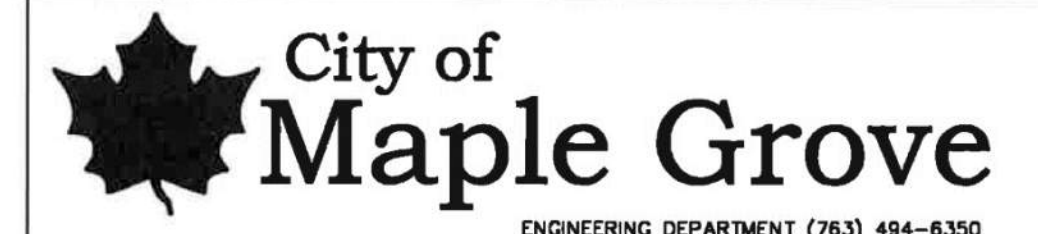

**VALVE AND HYDRANT
INSTALLATION**

Last Revision
Jan 2009

Plate Number
1005

CALL BEFORE YOU DIG!
Gopher State One Call
TWIN CITY AREA: 651-454-0002
TOLL FREE: 1-800-252-1166

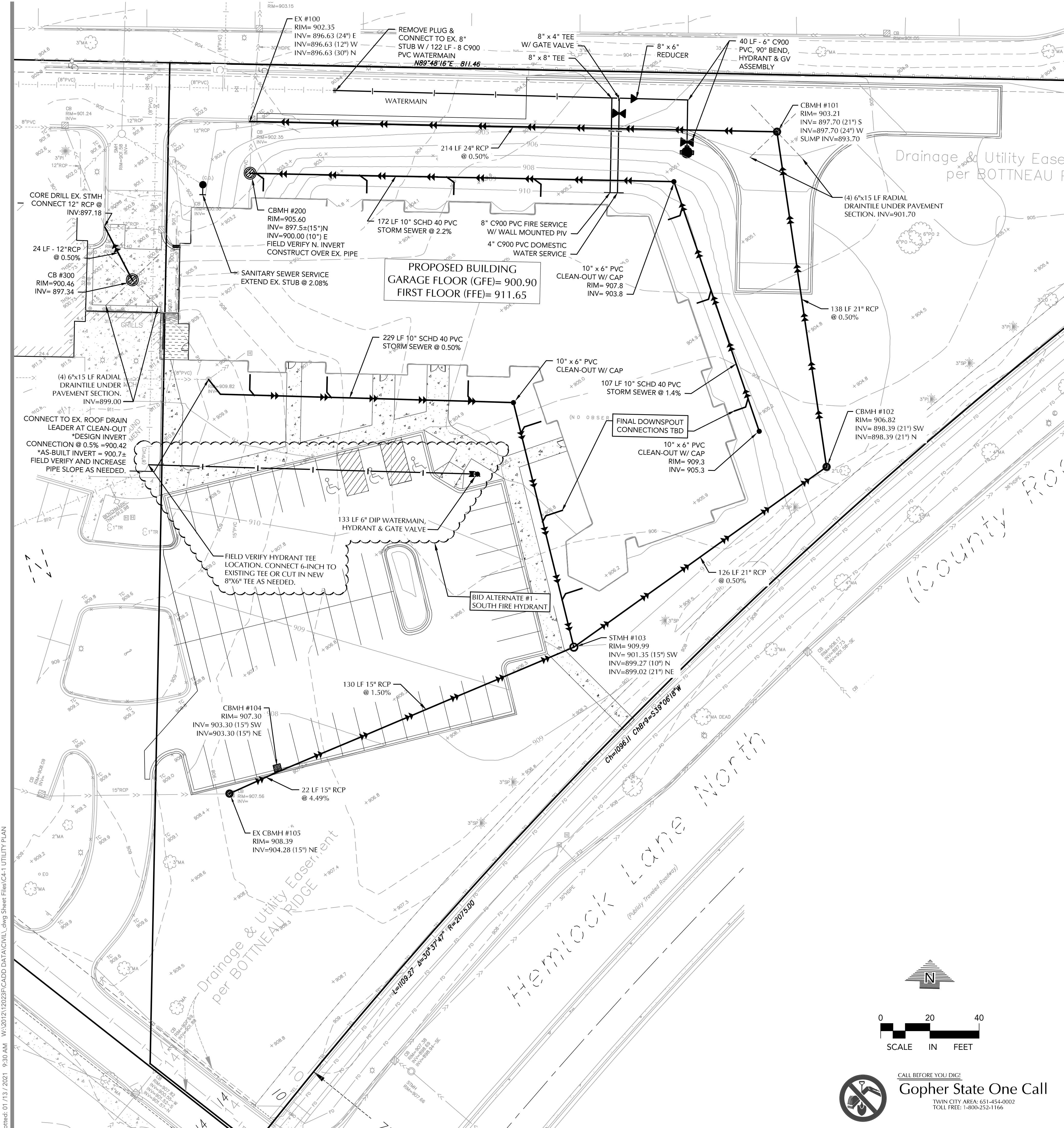

Plotted: 01/13/2021 9:30 AM W:\2021\12023F\CADD DATA\CIVIL.dwg Sheet Files\C4-1 UTILITY PLAN

SIGN BELOW TO SUBMIT BID:

Signature of Bidder; Title

NOTE: If bidder is a corporation, set forth the legal name of the corporation together with the signature of the officer or officers authorized to sign contracts on behalf of the corporation. If bidder is a partnership, set forth the name of the firm together with the signature of the partner or partners authorized to sign contracts on behalf of the partnership.

Business Address: (Full Mailing Address) _____

Email Address: _____

Telephone No.:

FAX No.:

TAX I.D. No.:
(if not incorporated)

Date Bid Proposal Submitted:

00 43 13 – BID SECURITY

Refer to Article 12, Section 00 21 13, Instructions to Bidders, for requirement for security which shall be attached to Bid Form.

00 52 00 - FORM OF AGREEMENT

Form of Agreement shall be AIA Document A101, current edition, "Standard Form of Agreement Between Owner and Contractor" Reference copy included at the end of this section. MHFA Documents listed in General Conditions.

00 61 13 - PERFORMANCE & LABOR & MATERIAL PAYMENT BONDS

Form of Bonds, if required, shall be Owner supplied forms attached at the end of this section. MHFA Documents listed in General Conditions.

00 62 16 - CERTIFICATE OF INSURANCE

Form of Certificate of Insurance shall be AIA Document G705, current edition, "Certificate of Insurance" or ACORD form 25-S.

MHFA Documents listed in General Conditions.

00 66 00 - SOIL REPORT

Soil Boring Log and Report for adjacent properties are attached at the end of this section.

00 72 00 - GENERAL CONDITIONS

The General Conditions of the Contract for Construction, AIA Document A-201, current edition, containing Articles 1 through 14, are hereby made a part of these specifications to the same extent as if bound herein.



AIA[®] Document A101[™] – 2007

Standard Form of Agreement Between Owner and Contractor where the basis of payment is a Stipulated Sum

AGREEMENT made as of the day of in the year
(In words, indicate day, month and year.)

BETWEEN the Owner:
(Name, legal status, address and other information)

and the Contractor:
(Name, legal status, address and other information)

for the following Project:
(Name, location and detailed description)

The Architect:
(Name, legal status, address and other information)

The Owner and Contractor agree as follows.

ADDITIONS AND DELETIONS:

The author of this document has added information needed for its completion. The author may also have revised the text of the original AIA standard form. An *Additions and Deletions Report* that notes added information as well as revisions to the standard form text is available from the author and should be reviewed. A vertical line in the left margin of this document indicates where the author has added necessary information and where the author has added to or deleted from the original AIA text.

This document has important legal consequences. Consultation with an attorney is encouraged with respect to its completion or modification.

AIA Document A201[™]–2007, General Conditions of the Contract for Construction, is adopted in this document by reference. Do not use with other general conditions unless this document is modified.

Init.

AIA Document A101[™] – 2007. Copyright © 1915, 1918, 1925, 1937, 1951, 1958, 1961, 1963, 1967, 1974, 1977, 1987, 1991, 1997 and 2007 by The American Institute of Architects. All rights reserved. WARNING: This AIA[®] Document is protected by U.S. Copyright Law and International Treaties. Unauthorized reproduction or distribution of this AIA[®] Document, or any portion of it, may result in severe civil and criminal penalties, and will be prosecuted to the maximum extent possible under the law. This document was produced by AIA software at 08:41:52 on 01/02/2013 under Order No.3502576910_1 which expires on 05/07/2013, and is not for resale.

User Notes:

(1632398946)

TABLE OF ARTICLES

1	THE CONTRACT DOCUMENTS
2	THE WORK OF THIS CONTRACT
3	DATE OF COMMENCEMENT AND SUBSTANTIAL COMPLETION
4	CONTRACT SUM
5	PAYMENTS
6	DISPUTE RESOLUTION
7	TERMINATION OR SUSPENSION
8	MISCELLANEOUS PROVISIONS
9	ENUMERATION OF CONTRACT DOCUMENTS
10	INSURANCE AND BONDS

ARTICLE 1 THE CONTRACT DOCUMENTS

The Contract Documents consist of this Agreement, Conditions of the Contract (General, Supplementary and other Conditions), Drawings, Specifications, Addenda issued prior to execution of this Agreement, other documents listed in this Agreement and Modifications issued after execution of this Agreement, all of which form the Contract, and are as fully a part of the Contract as if attached to this Agreement or repeated herein. The Contract represents the entire and integrated agreement between the parties hereto and supersedes prior negotiations, representations or agreements, either written or oral. An enumeration of the Contract Documents, other than a Modification, appears in Article 9.

ARTICLE 2 THE WORK OF THIS CONTRACT

The Contractor shall fully execute the Work described in the Contract Documents, except as specifically indicated in the Contract Documents to be the responsibility of others.

ARTICLE 3 DATE OF COMMENCEMENT AND SUBSTANTIAL COMPLETION

§ 3.1 The date of commencement of the Work shall be the date of this Agreement unless a different date is stated below or provision is made for the date to be fixed in a notice to proceed issued by the Owner.

(Insert the date of commencement if it differs from the date of this Agreement or, if applicable, state that the date will be fixed in a notice to proceed.)

If, prior to the commencement of the Work, the Owner requires time to file mortgages and other security interests, the Owner's time requirement shall be as follows:

§ 3.2 The Contract Time shall be measured from the date of commencement.

§ 3.3 The Contractor shall achieve Substantial Completion of the entire Work not later than () days from the date of commencement, or as follows:

(Insert number of calendar days. Alternatively, a calendar date may be used when coordinated with the date of commencement. If appropriate, insert requirements for earlier Substantial Completion of certain portions of the Work.)

Init.

AIA Document A101™ – 2007. Copyright © 1915, 1918, 1925, 1937, 1951, 1958, 1961, 1963, 1967, 1974, 1977, 1987, 1991, 1997 and 2007 by The American Institute of Architects. All rights reserved. WARNING: This AIA® Document is protected by U.S. Copyright Law and International Treaties. Unauthorized reproduction or distribution of this AIA® Document, or any portion of it, may result in severe civil and criminal penalties, and will be prosecuted to the maximum extent possible under the law. This document was produced by AIA software at 08:41:52 on 01/02/2013 under Order No.3502576910_1 which expires on 05/07/2013, and is not for resale.

User Notes:

(1632398946)

Portion of Work

Substantial Completion Date

, subject to adjustments of this Contract Time as provided in the Contract Documents.
(Insert provisions, if any, for liquidated damages relating to failure to achieve Substantial Completion on time or for bonus payments for early completion of the Work.)

ARTICLE 4 CONTRACT SUM

§ 4.1 The Owner shall pay the Contractor the Contract Sum in current funds for the Contractor’s performance of the Contract. The Contract Sum shall be (\$), subject to additions and deductions as provided in the Contract Documents.

§ 4.2 The Contract Sum is based upon the following alternates, if any, which are described in the Contract Documents and are hereby accepted by the Owner:
(State the numbers or other identification of accepted alternates. If the bidding or proposal documents permit the Owner to accept other alternates subsequent to the execution of this Agreement, attach a schedule of such other alternates showing the amount for each and the date when that amount expires.)

§ 4.3 Unit prices, if any:
(Identify and state the unit price; state quantity limitations, if any, to which the unit price will be applicable.)

Item	Units and Limitations	Price Per Unit (\$0.00)
------	-----------------------	-------------------------

§ 4.4 Allowances included in the Contract Sum, if any:
(Identify allowance and state exclusions, if any, from the allowance price.)

Item	Price
------	-------

ARTICLE 5 PAYMENTS

§ 5.1 PROGRESS PAYMENTS

§ 5.1.1 Based upon Applications for Payment submitted to the Architect by the Contractor and Certificates for Payment issued by the Architect, the Owner shall make progress payments on account of the Contract Sum to the Contractor as provided below and elsewhere in the Contract Documents.

§ 5.1.2 The period covered by each Application for Payment shall be one calendar month ending on the last day of the month, or as follows:

§ 5.1.3 Provided that an Application for Payment is received by the Architect not later than the day of a month, the Owner shall make payment of the certified amount to the Contractor not later than the day of the month. If an Application for Payment is received by the Architect after the application date fixed above, payment shall be made by the Owner not later than () days after the Architect receives the Application for Payment.
(Federal, state or local laws may require payment within a certain period of time.)

§ 5.1.4 Each Application for Payment shall be based on the most recent schedule of values submitted by the Contractor in accordance with the Contract Documents. The schedule of values shall allocate the entire Contract Sum among the various portions of the Work. The schedule of values shall be prepared in such form and supported by such data to substantiate its accuracy as the Architect may require. This schedule, unless objected to by the Architect, shall be used as a basis for reviewing the Contractor’s Applications for Payment.

Init.

§ 5.1.5 Applications for Payment shall show the percentage of completion of each portion of the Work as of the end of the period covered by the Application for Payment.

§ 5.1.6 Subject to other provisions of the Contract Documents, the amount of each progress payment shall be computed as follows:

- .1 Take that portion of the Contract Sum properly allocable to completed Work as determined by multiplying the percentage completion of each portion of the Work by the share of the Contract Sum allocated to that portion of the Work in the schedule of values, less retainage of percent (%). Pending final determination of cost to the Owner of changes in the Work, amounts not in dispute shall be included as provided in Section 7.3.9 of AIA Document A201™–2007, General Conditions of the Contract for Construction;
- .2 Add that portion of the Contract Sum properly allocable to materials and equipment delivered and suitably stored at the site for subsequent incorporation in the completed construction (or, if approved in advance by the Owner, suitably stored off the site at a location agreed upon in writing), less retainage of percent (%);
- .3 Subtract the aggregate of previous payments made by the Owner; and
- .4 Subtract amounts, if any, for which the Architect has withheld or nullified a Certificate for Payment as provided in Section 9.5 of AIA Document A201–2007.

§ 5.1.7 The progress payment amount determined in accordance with Section 5.1.6 shall be further modified under the following circumstances:

- .1 Add, upon Substantial Completion of the Work, a sum sufficient to increase the total payments to the full amount of the Contract Sum, less such amounts as the Architect shall determine for incomplete Work, retainage applicable to such work and unsettled claims; and
(Section 9.8.5 of AIA Document A201–2007 requires release of applicable retainage upon Substantial Completion of Work with consent of surety, if any.)
- .2 Add, if final completion of the Work is thereafter materially delayed through no fault of the Contractor, any additional amounts payable in accordance with Section 9.10.3 of AIA Document A201–2007.

§ 5.1.8 Reduction or limitation of retainage, if any, shall be as follows:

(If it is intended, prior to Substantial Completion of the entire Work, to reduce or limit the retainage resulting from the percentages inserted in Sections 5.1.6.1 and 5.1.6.2 above, and this is not explained elsewhere in the Contract Documents, insert here provisions for such reduction or limitation.)

§ 5.1.9 Except with the Owner's prior approval, the Contractor shall not make advance payments to suppliers for materials or equipment which have not been delivered and stored at the site.

§ 5.2 FINAL PAYMENT

§ 5.2.1 Final payment, constituting the entire unpaid balance of the Contract Sum, shall be made by the Owner to the Contractor when

- .1 the Contractor has fully performed the Contract except for the Contractor's responsibility to correct Work as provided in Section 12.2.2 of AIA Document A201–2007, and to satisfy other requirements, if any, which extend beyond final payment; and
- .2 a final Certificate for Payment has been issued by the Architect.

§ 5.2.2 The Owner's final payment to the Contractor shall be made no later than 30 days after the issuance of the Architect's final Certificate for Payment, or as follows:

ARTICLE 6 DISPUTE RESOLUTION

§ 6.1 INITIAL DECISION MAKER

The Architect will serve as Initial Decision Maker pursuant to Section 15.2 of AIA Document A201–2007, unless the parties appoint below another individual, not a party to this Agreement, to serve as Initial Decision Maker.

Init.

AIA Document A101™ – 2007. Copyright © 1915, 1918, 1925, 1937, 1951, 1958, 1961, 1963, 1967, 1974, 1977, 1987, 1991, 1997 and 2007 by The American Institute of Architects. All rights reserved. WARNING: This AIA® Document is protected by U.S. Copyright Law and International Treaties. Unauthorized reproduction or distribution of this AIA® Document, or any portion of it, may result in severe civil and criminal penalties, and will be prosecuted to the maximum extent possible under the law. This document was produced by AIA software at 08:41:52 on 01/02/2013 under Order No.3502576910_1 which expires on 05/07/2013, and is not for resale.

User Notes:

(1632398946)

(If the parties mutually agree, insert the name, address and other contact information of the Initial Decision Maker, if other than the Architect.)

§ 6.2 BINDING DISPUTE RESOLUTION

For any Claim subject to, but not resolved by, mediation pursuant to Section 15.3 of AIA Document A201–2007, the method of binding dispute resolution shall be as follows:

(Check the appropriate box. If the Owner and Contractor do not select a method of binding dispute resolution below, or do not subsequently agree in writing to a binding dispute resolution method other than litigation, Claims will be resolved by litigation in a court of competent jurisdiction.)

- Arbitration pursuant to Section 15.4 of AIA Document A201–2007
- Litigation in a court of competent jurisdiction
- Other *(Specify)*

ARTICLE 7 TERMINATION OR SUSPENSION

§ 7.1 The Contract may be terminated by the Owner or the Contractor as provided in Article 14 of AIA Document A201–2007.

§ 7.2 The Work may be suspended by the Owner as provided in Article 14 of AIA Document A201–2007.

ARTICLE 8 MISCELLANEOUS PROVISIONS

§ 8.1 Where reference is made in this Agreement to a provision of AIA Document A201–2007 or another Contract Document, the reference refers to that provision as amended or supplemented by other provisions of the Contract Documents.

§ 8.2 Payments due and unpaid under the Contract shall bear interest from the date payment is due at the rate stated below, or in the absence thereof, at the legal rate prevailing from time to time at the place where the Project is located.
(Insert rate of interest agreed upon, if any.)

%

§ 8.3 The Owner's representative:
(Name, address and other information)

§ 8.4 The Contractor's representative:
(Name, address and other information)

Init.

AIA Document A101™ – 2007. Copyright © 1915, 1918, 1925, 1937, 1951, 1958, 1961, 1963, 1967, 1974, 1977, 1987, 1991, 1997 and 2007 by The American Institute of Architects. All rights reserved. WARNING: This AIA® Document is protected by U.S. Copyright Law and International Treaties. Unauthorized reproduction or distribution of this AIA® Document, or any portion of it, may result in severe civil and criminal penalties, and will be prosecuted to the maximum extent possible under the law. This document was produced by AIA software at 08:41:52 on 01/02/2013 under Order No.3502576910_1 which expires on 05/07/2013, and is not for resale.

User Notes:

(1632398946)

§ 8.5 Neither the Owner's nor the Contractor's representative shall be changed without ten days written notice to the other party.

§ 8.6 Other provisions:

ARTICLE 9 ENUMERATION OF CONTRACT DOCUMENTS

§ 9.1 The Contract Documents, except for Modifications issued after execution of this Agreement, are enumerated in the sections below.

§ 9.1.1 The Agreement is this executed AIA Document A101-2007, Standard Form of Agreement Between Owner and Contractor.

§ 9.1.2 The General Conditions are AIA Document A201-2007, General Conditions of the Contract for Construction.

§ 9.1.3 The Supplementary and other Conditions of the Contract:

Document	Title	Date	Pages
----------	-------	------	-------

§ 9.1.4 The Specifications:

(Either list the Specifications here or refer to an exhibit attached to this Agreement.)

Section	Title	Date	Pages
---------	-------	------	-------

§ 9.1.5 The Drawings:

(Either list the Drawings here or refer to an exhibit attached to this Agreement.)

Number	Title	Date
--------	-------	------

§ 9.1.6 The Addenda, if any:

Number	Date	Pages
--------	------	-------

Portions of Addenda relating to bidding requirements are not part of the Contract Documents unless the bidding requirements are also enumerated in this Article 9.

§ 9.1.7 Additional documents, if any, forming part of the Contract Documents:

.1 AIA Document E201™-2007, Digital Data Protocol Exhibit, if completed by the parties, or the following:

.2 Other documents, if any, listed below:

(List here any additional documents that are intended to form part of the Contract Documents. AIA Document A201-2007 provides that bidding requirements such as advertisement or invitation to bid, Instructions to Bidders, sample forms and the Contractor's bid are not part of the Contract Documents)

AIA Document A101™ - 2007. Copyright © 1915, 1918, 1925, 1937, 1951, 1958, 1961, 1963, 1967, 1974, 1977, 1987, 1991, 1997 and 2007 by The American Institute of Architects. All rights reserved. WARNING: This AIA® Document is protected by U.S. Copyright Law and International Treaties. Unauthorized reproduction or distribution of this AIA® Document, or any portion of it, may result in severe civil and criminal penalties, and will be prosecuted to the maximum extent possible under the law. This document was produced by AIA software at 08:41:52 on 01/02/2013 under Order No.3502576910_1 which expires on 05/07/2013, and is not for resale.

User Notes:

(1632398946)

unless enumerated in this Agreement. They should be listed here only if intended to be part of the Contract Documents.)

ARTICLE 10 INSURANCE AND BONDS

The Contractor shall purchase and maintain insurance and provide bonds as set forth in Article 11 of AIA Document A201-2007.

(State bonding requirements, if any, and limits of liability for insurance required in Article 11 of AIA Document A201-2007.)

Type of insurance or bond

Limit of liability or bond amount (\$0.00)

This Agreement entered into as of the day and year first written above.

OWNER (Signature)

CONTRACTOR (Signature)

(Printed name and title)

(Printed name and title)

Init.

Geotechnical Evaluation Report

Bottineau Ridge Apartments - Phase III
11875 80th Avenue North
Maple Grove, Minnesota

Prepared for

Duffy Development Company, Inc.

Professional Certification:

I hereby certify that this plan, specification, or report was prepared by me or under my direct supervision and that I am a duly licensed Professional Engineer under the laws of the State of Minnesota.

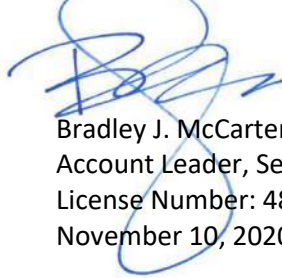

Bradley J. McCarter, PE
Account Leader, Senior Engineer
License Number: 48478
November 10, 2020



November 10, 2020

Project B2008300

Mr. Jeff Von Feldt
Duffy Development Company, Inc.
12708 Wayzata Boulevard, Suite 400
Minnetonka, MN 55305

Re: Geotechnical Evaluation
Bottineau Ridge Apartments - Phase III
11875 80th Avenue North
Maple Grove, Minnesota

Dear Mr. Von Feldt:

We are pleased to present this Geotechnical Evaluation Report for the proposed Phase II addition at the Bottineau Ridge Apartment Complex. The following report provides the results of our evaluation and should be read in its entirety.

Thank you for making Braun Intertec your geotechnical consultant for this project. If you have questions about this report, or if there are other services that we can provide in support of our work to date, please contact Austin Bizal at 612.357.5257 (abizal@braunintertec.com) or Brad McCarter at 612.708.2790 (bmccarter@braunintertec.com).

Sincerely,

BRAUN INTERTEC CORPORATION



Austin M. Bizal, EIT
Staff Engineer



Bradley J. McCarter, PE
Account Leader, Senior Engineer

Table of Contents

Description	Page
A. Introduction.....	1
A.1. Project Description.....	1
A.2. Site Conditions and History.....	2
A.3. Purpose.....	3
A.4. Background Information and Reference Documents.....	3
A.5. Scope of Services.....	3
B. Results.....	4
B.1. Geologic Overview.....	4
B.2. Boring Results.....	5
B.3. Groundwater.....	6
B.4. Laboratory Test Results.....	6
C. Recommendations.....	6
C.1. Design and Construction Discussion.....	6
C.1.a. Building Subgrade Preparation.....	6
C.1.b. Reuse of On-Site Soils.....	7
C.1.c. Groundwater.....	7
C.1.d. Construction Disturbance.....	7
C.1.e. Pavements.....	8
C.2. Site Grading and Subgrade Preparation.....	8
C.2.a. Building Subgrade Excavations.....	8
C.2.b. Excavation Oversizing.....	8
C.2.c. Excavated Slopes.....	9
C.2.d. Excavation Dewatering.....	10
C.2.e. Engineered Fill Materials and Compaction.....	10
C.2.f. Special Inspection of Soils.....	11
C.3. Spread Footings.....	12
C.4. Construction Adjacent to Existing Structures.....	12
C.4.a. Excavations.....	12
C.4.b. Footing Depth.....	12
C.4.c. Settlement.....	13
C.5. Basement Walls.....	13
C.5.a. Drainage Control.....	13
C.5.b. Configuring and Resisting Lateral Loads.....	14
C.6. Interior Slabs.....	15
C.6.a. Subgrade Modulus.....	15
C.6.b. Moisture Vapor Protection.....	15
C.7. Frost Protection.....	16
C.8. Pavements.....	17
C.8.a. Pavement Subgrade Preparation.....	17
C.8.b. Pavement Subgrade Proofroll.....	17
C.8.c. Design Sections.....	18
C.8.d. Bituminous Pavement Materials.....	18
C.8.e. Concrete Pavements.....	18
C.8.f. Subgrade Drainage.....	18
C.8.g. Performance and Maintenance.....	19

Table of Contents (continued)

Description	Page
C.9. Utilities	19
C.9.a. Subgrade Stabilization	19
C.9.b. Utility Trench Backfill	19
C.9.c. Corrosion Potential	20
C.10. Stormwater.....	20
C.11. Equipment Support	20
D. Procedures.....	20
D.1. Penetration Test Borings.....	20
D.2. Exploration Logs	21
D.2.a. Log of Boring Sheets.....	21
D.2.b. Geologic Origins	21
D.3. Material Classification and Testing	21
D.3.a. Visual and Manual Classification.....	21
D.3.b. Laboratory Testing	22
D.4. Groundwater Measurements.....	22
E. Qualifications.....	22
E.1. Variations in Subsurface Conditions.....	22
E.1.a. Material Strata	22
E.1.b. Groundwater Levels	22
E.2. Continuity of Professional Responsibility.....	23
E.2.a. Plan Review	23
E.2.b. Construction Observations and Testing	23
E.3. Use of Report.....	23
E.4. Standard of Care.....	23

Appendix

Soil Boring Location Sketch

Log of Boring Sheets (ST-1 to ST-6)

Descriptive Terminology of Soil

A. Introduction

A.1. Project Description

This Geotechnical Evaluation Report addresses the design and construction of the proposed Phase III addition to the Bottineau Ridge apartment complex located at 11875 80th Avenue North in Maple Grove, Minnesota. The project will include the construction of an addition on the east side of the existing apartment building with 4 stories and one basement level. In addition to the building, associated parking lots, utilities, outdoor patios, and stormwater features will also be constructed. Table 1 provides a summary of project details.

Table 1. Building Summary

Aspect	Description
Below grade levels	1
Above grade levels	4
Basement floor elevation (feet MSL)	Match Existing = 901
Column loads (kips)	350 (Assumed)
Wall loads (kips per linear foot)	6 to 8 (Assumed)
Nature of construction	The building will have below and at grade masonry walls and precast concrete columns/planks with wood framing above and a grade supported concrete slab.
Site Grading	We anticipate that general exterior site grades will be altered by less than about 3 feet during grading not including excavations to reach basement grades.
Pavements	Bituminous paved parking lot and drive lanes with some concrete flatwork. Light-duty loads: 35,000 ESALs* Heavy-duty loads: 100,000 ESALs*
Site Improvements	New utility installations including water, sanitary and storm sewer with invert elevations within about 8 feet of finished grades.

*Equivalent 18,000-lb single axle loads based on 20-year design.

The figure below shows an illustration of the proposed site layout.

Figure 1. Site Layout

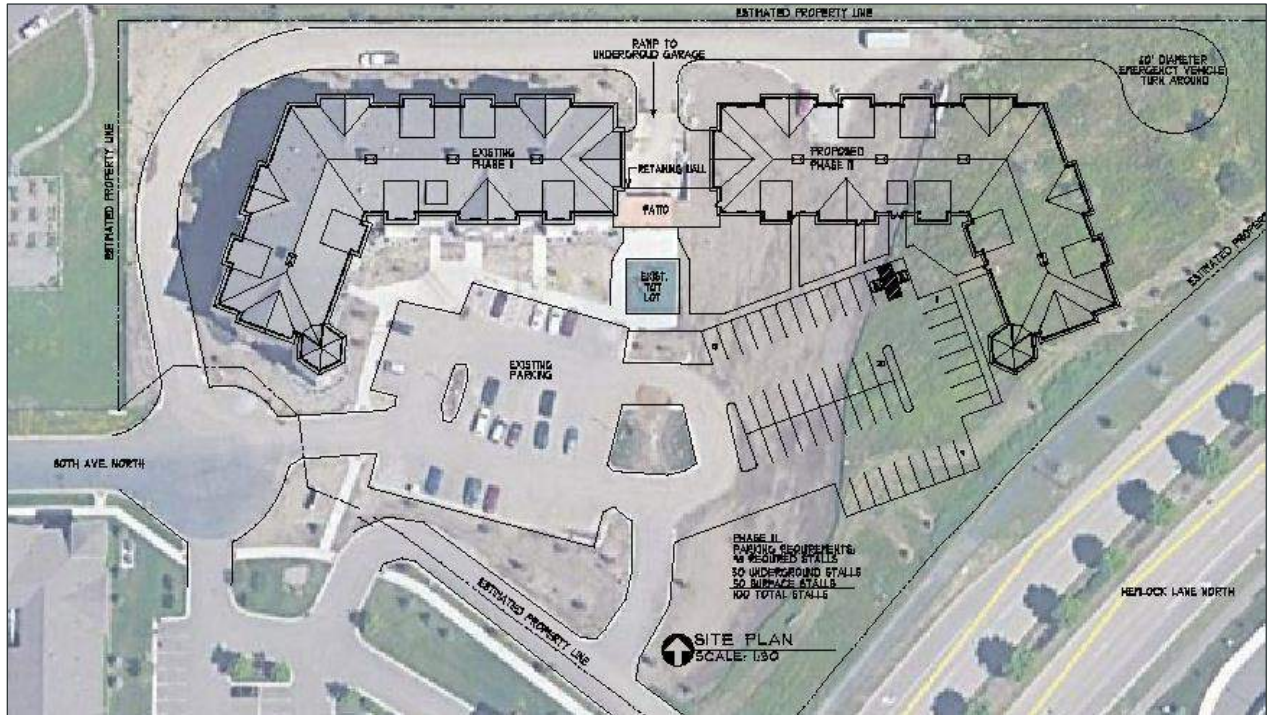

Figure provided by Cole Group Architects, LLC dated May 1, 2020.

A.2. Site Conditions and History

The project consists of 1 parcel approximately 2 1/2 acres of land located in Maple Grove, Minnesota. This area of Maple Grove has historically been mined for sand and gravel. Braun Intertec Corporation has completed excavations observations and compaction testing supporting mine reclamation on this site and adjacent sites. Braun Intertec also completed a Geotechnical Evaluation Report for the Bottineau Ridge Phase I and Phase II reports. Based on the results of those borings, we anticipate that the site may contain up to 15 feet of existing fill associated with mine reclamation.

Current site grades are generally flat with elevations ranging from about 903 to 906 feet mean sea level (MSL).

A.3. Purpose

The purpose of our geotechnical evaluation will be to characterize subsurface geologic conditions at selected exploration locations, evaluate their impact, and provide geotechnical recommendations for the design and construction of the apartment building.

A.4. Background Information and Reference Documents

We reviewed the following information:

- Preliminary Site Plan prepared by Cole Group Architects, LLC, dated May 1, 2020.
- Topographic maps from the Minnesota Department of Natural Resource's MnTOPO website and historic aerial photographs from the online Hennepin County Geographic Information Systems (GIS) catalog.
- Previous Geotechnical Evaluation Reports prepared by Braun Intertec and dated December 16, 2016 and (Braun Intertec Project No. B1611164) and dated March 6, 2013 (Braun Intertec Project No. SP-13-00212).
- A previous construction materials testing report prepared by Braun Intertec dated January 26, 2005 (Braun Intertec Project No. BN-04-03896).

We have described our understanding of the proposed construction and site to the extent others reported it to us. Depending on the extent of available information, we may have made assumptions based on our experience with similar projects. If we have not correctly recorded or interpreted the project details, the project team should notify us. New or changed information could require additional evaluation, analyses and/or recommendations.

A.5. Scope of Services

We performed our scope of services for the project in accordance with our Proposal for Geotechnical Evaluation (QTB126913), dated September 17, 2020. The following list describes the geotechnical tasks completed in accordance with our authorized scope of services.

- Reviewing the background information and reference documents previously cited.
- Staking and clearing the exploration location of underground utilities. Duffy Development Company, Inc. selected and we staked the new exploration locations. We acquired the surface elevations and locations with GPS technology using the State of Minnesota's permanent GPS base station network. The Soil Boring Location Sketch included in the Appendix shows the approximate locations of the borings.
- Performing 6 standard penetration test (SPT) borings, denoted as ST-1 to ST-6, to nominal depths of 10 to 25 feet below grade across the site.
- Performing laboratory testing on select samples to aid in soil classification and engineering analysis.
- Preparing this report containing a boring location sketch, logs of soil borings, the results of our evaluation, and recommendations for structure and pavement subgrade preparation and for use in the design and construction of foundations, below grade walls, floor slabs, exterior slabs, utilities, stormwater improvements, and pavements.

Our scope of services did not include environmental services or testing and our geotechnical personnel performing this evaluation are not trained to provide environmental services or testing. We can provide environmental services or testing at your request.

B. Results

B.1. Geologic Overview

We based the geologic origins used in this report on the soil types, in-situ and laboratory testing, and available common knowledge of the geological history of the site. Because of the complex depositional history, geologic origins can be difficult to ascertain. We did not perform a detailed investigation of the geologic history for the site.

B.2. Boring Results

Table 2 provides a summary of the soil boring results, in the general order we encountered the strata. Please refer to the Log of Boring sheet in the Appendix for additional details. The Descriptive Terminology sheet in the Appendix include definitions of abbreviations used in Table 2.

Table 2. Subsurface Profile Summary

Strata	Soil Type - ASTM Classification	N-Values	Commentary and Details
Topsoil Fill	SM	---	<ul style="list-style-type: none"> ▪ Dark brown to black with varying organic content. ▪ Thicknesses at boring locations varied from about 1/2- to 1-foot. ▪ Moisture condition generally moist.
Fill	SP, SP-SM, SM, SC, CL	8 to 50+	<ul style="list-style-type: none"> ▪ Encountered in each boring to depths ranging from about 10 to 16 feet below grade. ▪ Moisture condition generally moist to dry ▪ Highly variable, soils intermixed. ▪ Existing fill at boring ST-1 contained trace amounts of brick debris. ▪ Contains gravel, elevated blow counts indicative of heavier concentrations of gravel or possible cobbles and boulders.
Glacial Deposits	SP, SP-SM	2 to 33	<ul style="list-style-type: none"> ▪ Relative densities generally ranged from loose to medium dense with lower values likely impacted by the presence of groundwater. ▪ Variable amounts of gravel; may contain cobbles and boulders. ▪ Moisture condition generally moist to wet below the water table.

For simplicity in this report, we define existing fill to mean existing, uncontrolled or undocumented fill.

B.3. Groundwater

Table 3 summarizes the depths where we observed groundwater; the attached Log of Boring sheets in the Appendix also include this information and additional details.

Table 3. Groundwater Summary

Location	Surface Elevation (feet MSL)	Measured or Estimated Depth to Groundwater (feet)	Corresponding Groundwater Elevation (feet MSL)
ST-1	903.9	15	889
ST-2	904.9	15	890
ST-3	905.3	21	884 1/2
ST-4	906.1	16	890

At the time of our observation, the groundwater appears to be near, or below, about elevation 890 feet MSL. Project planning should expect groundwater will fluctuate in relation to the time of construction.

B.4. Laboratory Test Results

The boring logs show the results of moisture content and P200 testing we performed, next to the tested sample depth. The Appendix contains the results of these tests.

C. Recommendations

C.1. Design and Construction Discussion

C.1.a. Building Subgrade Preparation

Based on the results of the borings and the anticipated basement floor elevation at 901 feet MSL, the new footings for the planned addition will bear in existing fill material underlain by native glacial deposits. The existing fill material is generally consistent with the fill as documented by Braun Intertec during the previous reclamation activities on site. Thus, we anticipate the planned building addition can

be supported by conventional spread footings bearing on stable existing fill. We recommend that careful subgrade evaluations be performed at the time of construction to help identify any zones or pockets or soft fill that may require some corrective active prior to construction. Where encountered, any zones of unstable fill should be subcut and replaced with engineered fill.

C.1.b. Reuse of On-Site Soils

The existing, non-organic, debris-free, fill is generally considered suitable for reuse as engineered fill provided it can be adequately moisture conditioned and compacted. We do not recommend reusing existing fill that contains zones of debris or organic material as structural fill.

As we expect this site to have a net export of soil, we recommend retaining the most suitable soils for use on this site. Generally, the most suitable soils are granular soils, close to their optimum moisture content.

Any materials to be reused as engineered fill should be tested and approved by the engineer prior to placement.

C.1.c. Groundwater

We observed groundwater in the borings near, or below, about elevation 890 feet MSL. Where we observed groundwater, it is below the anticipated excavation depths for construction. However, we recommend removing any collected water from within excavations to facilitate proper backfilling or concrete placement. Based upon the borings, we anticipate sumps and pumps would be suitable for temporary dewatering activities at this site. We recommend the contractor remove any water that collects in work areas before performing further work.

C.1.d. Construction Disturbance

The contractor should note the on-site, clayey and silty soils are highly susceptible to disturbance, due to repeated construction traffic. Disturbance of these soils may cause areas that were previously prepared, or that were suitable for pavement or structure support, to become unstable and require moisture conditioning and compaction. Subcutting and replacing the disturbed material with crushed, coarse gravel, free of fines is also an alternative. The contractor should use means and methods to limit disturbance of the soils.

C.1.e. Pavements

The existing fill consists of a variety of materials and strengths. This variability creates the potential for irregular pavement support. The contractor should anticipate surface compacting and proofrolling the exposed soils to identify weak spots in the pavement subgrade. Subcuts on the order of about 2 feet should be anticipated in isolated areas to correct pavement subgrades.

C.2. Site Grading and Subgrade Preparation

C.2.a. Building Subgrade Excavations

Based on the borings, new footings for the planned addition will bear in existing fill that was generally documented during previous grading activities. We recommend thorough subgrade evaluations be performed to help identify any weak zones that may require additional soil corrections. However, extensive soil correction excavations are not expected within the building footprint below the anticipated basement floor elevation of 901 feet MSL.

Excavation depths will vary between the borings. Portions of the excavations may also extend deeper than indicated by the borings. A geotechnical representative should observe the excavations to make the necessary field judgments regarding the suitability of the exposed soils.

The contractor should use equipment and techniques to minimize soil disturbance. If soils become disturbed or are wet, we recommend excavation, replacement and recompaction.

C.2.b. Excavation Oversizing

When removing unsuitable materials below structures, we recommend the excavation extend outward and downward at a slope of 1H:1V (horizontal:vertical) or flatter. See Figure 2 for an illustration of excavation oversizing.

Figure 2. Generalized Illustration of Oversizing

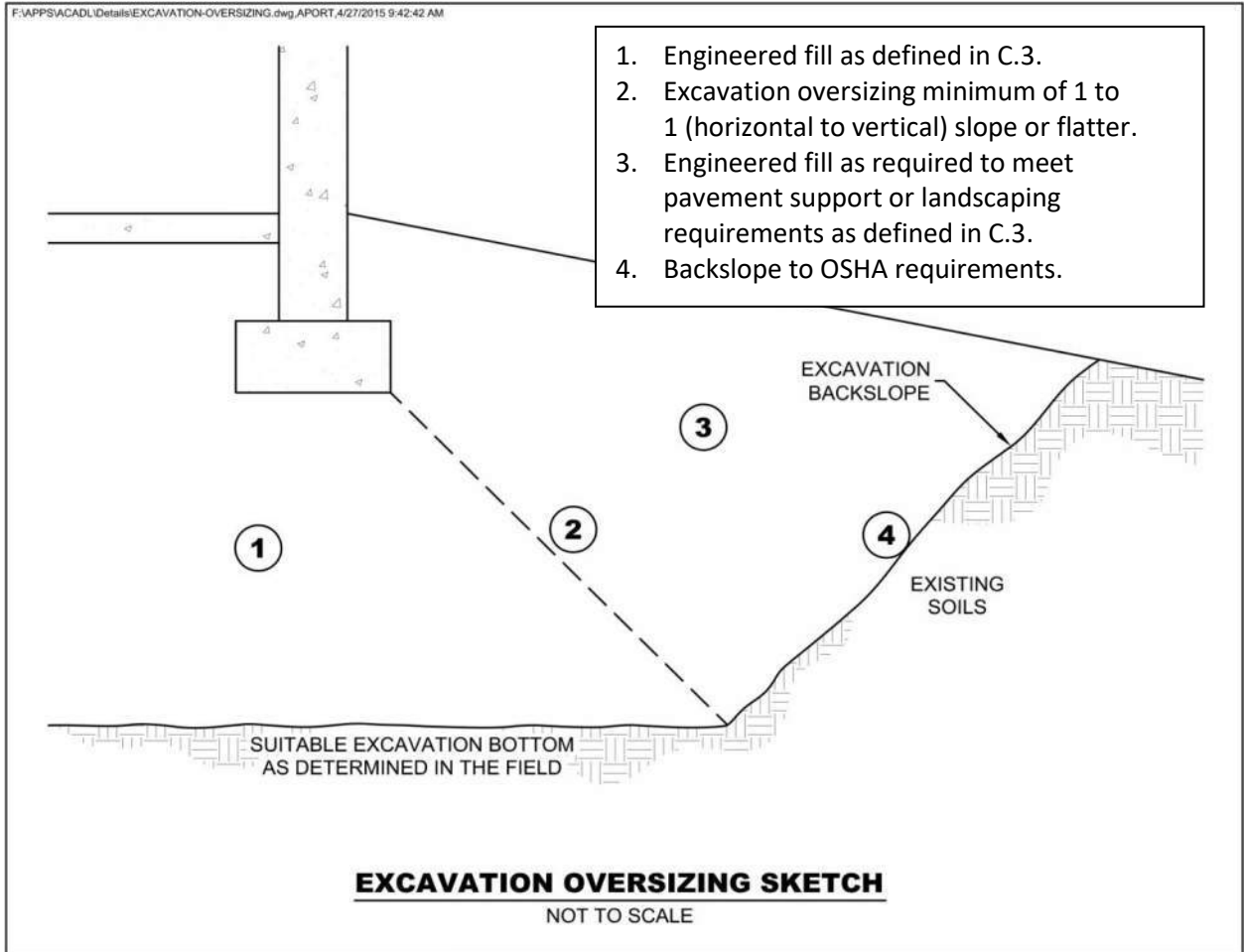

C.2.c. Excavated Slopes

Based on the borings, we anticipate on-site soils in excavations will consist of mixed sand and clay fill soils. These soils are typically considered Type C Soil under OSHA (Occupational Safety and Health Administration) guidelines. OSHA guidelines indicate unsupported excavations in Type B soils should have a gradient no steeper than 1 1/2H:1V. Slopes constructed in this manner may still exhibit surface sloughing. OSHA requires an engineer to evaluate any slopes or excavations over 20 feet in depth.

An OSHA-approved qualified person should review the soil classification in the field. Excavations must comply with the requirements of OSHA 29 CFR, Part 1926, Subpart P, "Excavations and Trenches." This document states excavation safety is the responsibility of the contractor. The project specifications should reference these OSHA requirements.

C.2.d. Excavation Dewatering

We recommend removing any collected water from the excavations. Project planning should include temporary sumps and pumps to remove any collected water from excavations prior to construction at this site.

C.2.e. Engineered Fill Materials and Compaction

Table 4 below contains our recommendations for engineered fill materials.

Table 4. Engineered Fill Materials*

Locations to Be Used	Engineered Fill Classification	Possible Soil Type Descriptions	Gradation	Additional Requirements
<ul style="list-style-type: none"> ▪ Below foundations ▪ Below interior slabs 	Structural fill	SP, SP-SM, SM	100% passing 2-inch sieve < 25% passing #200 sieve	< 2% Organic Content (OC)
<ul style="list-style-type: none"> ▪ Drainage layer ▪ Non-frost-susceptible 	<ul style="list-style-type: none"> ▪ Free-draining ▪ Non-frost-susceptible fill ▪ Clean Sand 	SP	100% passing 1-inch sieve < 50% passing #40 sieve < 5% passing #200 sieve	< 2% OC
Behind below-grade walls, beyond drainage layer	Retained fill	SP, SP-SM, SM	100% passing 3-inch sieve < 20% passing #200 sieve	< 2% OC Plasticity Index (PI) < 4%
Pavements	Pavement fill	SP, SP-SM, SM, SC	100% passing 3-inch sieve	< 3% OC

*More select soils comprised of coarse sands with < 5% passing #200 sieve may be needed to accommodate work occurring in periods of wet or freezing weather.

We recommend spreading engineered fill in loose lifts of approximately 8 inches thick. We recommend compacting engineered fill in accordance with the criteria presented below in Table 5. The project documents should specify relative compaction of engineered fill, based on the structure located above the engineered fill, and vertical proximity to that structure.

Table 5. Compaction Recommendations Summary

Reference	Relative Compaction, percent (ASTM D698 – Standard Proctor)	Moisture Content Variance from Optimum, percentage points	
		Sand (Typically SP, SP-SM)	Silty and Clayey Soils (Typically SC, SM)
Below foundations and oversizing zones	98	±3	-1 to +3
Below interior slabs	98	±3	-1 to +3
Within 3 feet of pavement subgrade	100	±3	-2 to +1
More than 3 feet below pavement subgrade	95	±3	±3

The project documents should not allow the contractor to use frozen material as engineered fill or to place engineered fill on frozen material. Frost should not penetrate under foundations during construction.

We recommend performing density tests in engineered fill to evaluate if the contractors are effectively compacting the soil and meeting project requirements.

C.2.f. Special Inspection of Soils

We recommend including the site grading and placement of engineered fill within the building pad under the requirements of Special Inspections, as provided in Chapter 17 of the International Building Code, which is part of the Minnesota State Building Code. Special Inspection requires observation of soil conditions below engineered fill or footings, evaluations to determine if excavations extend to the anticipated soils, and if engineered fill materials meet requirements for type of engineered fill and compaction condition of engineered fill. A licensed geotechnical engineer should direct the Special Inspections of site grading and engineered fill placement. The purpose of these Special Inspections is to evaluate whether the work is in accordance with the approved Geotechnical Report for the project. Special Inspections should include evaluation of the subgrade, observing preparation of the subgrade (surface compaction or dewatering, excavation oversizing, placement procedures and materials used for engineered fill, etc.) and compaction testing of the engineered fill.

C.3. Spread Footings

Table 6 below contains our recommended parameters for foundation design for spread footings bearing on stable existing fill or new engineered fill.

Table 6. Spread Footing Design Parameters

Item	Description
Maximum net allowable bearing pressure (psf)	3,000
Minimum factor of safety for bearing capacity failure	3.0
Minimum width (inches)	Strip footing – 24 Column footing – 36
Minimum embedment below final exterior grade for heated structures (inches)	42
Minimum embedment below final exterior grade for unheated structures or for footings not protected from freezing temperatures during construction (inches)	60
Total estimated settlement (inches)	1
Differential settlement	Typically about 2/3 of total settlement

C.4. Construction Adjacent to Existing Structures

C.4.a. Excavations

Excavations for the planned addition will bear at similar elevation to those of the existing building. Care should be taken not to undermine or disturb the existing footings. After reaching the design depth, a geotechnical representative should observe the excavation bottom to evaluate the suitability of the soils near the existing foundation for support of the new floor slab and foundation. We recommend contacting us if excavations need to extend below the bearing elevation of the existing footing.

C.4.b. Footing Depth

New building foundations constructed adjacent to the foundations of the existing building may exert additional stresses on existing foundations. In general, we recommend constructing new foundations to bear at the same elevation as the existing foundations. We also recommend lowering or offsetting foundations so a foundation or its oversize zone does not exert a load on adjacent structures.

C.4.c. Settlement

Due to the existing building not likely settling with the proposed addition, approximately 1/2 inch of differential settlement could occur between the existing building and the addition. To accommodate this settlement, we recommend connecting the addition to the building later in the construction process after most of the dead load is in place on the addition. We also recommend installing expansion joints between the existing building and the addition or designing the structure to accommodate differential movement.

C.5. Basement Walls

C.5.a. Drainage Control

We recommend installing drain tile to remove water behind the basement walls, at the location shown in Figure 3. The basement wall drainage system should also incorporate free-draining, engineered fill or a drainage board placed against the wall and connected to the drain tile.

Even with the use of free-draining, engineered fill, we recommend general waterproofing of below-grade walls that surround occupied or potentially occupied areas because of the potential cost impacts related to seepage after construction is complete.

Figure 3. Generalized Illustration of Wall Engineered Fill

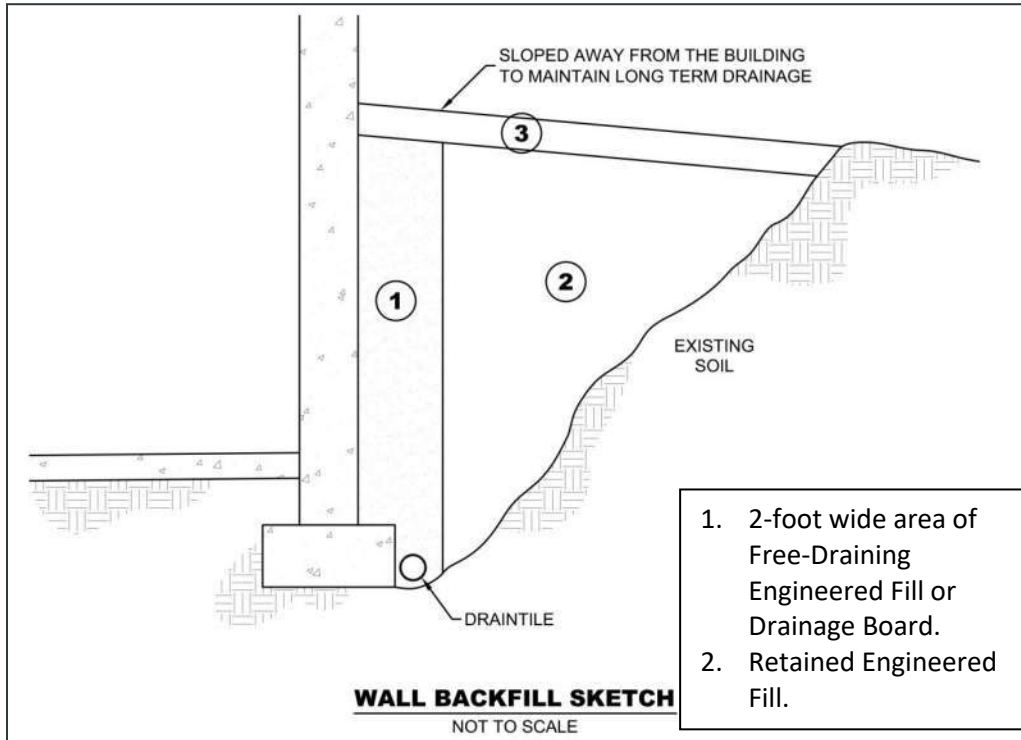

The materials listed in the sketch should meet the definitions in Section C.2.e. Low-permeability material is capable of directing water away from the wall, like clay, topsoil or pavement. The project documents should indicate if the contractor should brace the walls prior to filling and allowable unbalanced fill heights. As shown in Figure 3, we recommend Zone 2 consist of retained, engineered fill, and this material will control lateral pressures on the wall.

C.5.b. Configuring and Resisting Lateral Loads

Basement wall design can use active earth pressure conditions, if the walls can rotate slightly. If the wall design cannot tolerate rotation, then design should use at-rest earth pressure conditions. Rotation up to 0.002 times the wall height is generally required for walls supporting sand.

Table 7 presents our recommended lateral coefficients and equivalent fluid pressures for wall design of active, at-rest and passive earth pressure conditions. The table also provides recommended wet unit weights and internal friction angles.

Table 7. Below-Grade Wall Design Parameters – Drained Conditions

Retained Soil	Wet Unit Weight (pcf)	Friction Angle (degrees)	Active Lateral Coefficient	At-Rest Lateral Coefficient	Passive Lateral Coefficient
Existing Fill (SM/SC)	130	26	0.39	2.56	0.56
Imported Sand (SP, SP-SM)	120	34	0.28	3.54	0.44

*Based on Rankine model for soils in a region behind the wall extending at least 2 horizontal feet beyond the bottom outer edges of the wall footings and then rising up and away from the wall at an angle no steeper than 60 degrees from horizontal.

Designs should also consider the slope of any engineered fill and dead or live loads placed behind the walls within a horizontal distance that is equal to the height of the walls. Our recommended values assume the wall design provides drainage so water cannot accumulate behind the walls. The construction documents should clearly identify what soils the contractor should use for engineered fill of walls.

Sliding resistance between the bottom of the footing and the soil can also resist lateral pressures. We recommend assuming a sliding coefficient equal to 0.4 between the concrete and soil.

The values presented in this section are un-factored.

C.6. Interior Slabs

C.6.a. Subgrade Modulus

The anticipated floor subgrade will consist of suitable existing fill. We recommend using a modulus of subgrade reaction, k, of 150 pounds per square inch per inch of deflection (pci) to design the slabs. If the slab design requires placing 6 inches of compacted crushed aggregate base immediately below the slab, the slab design may increase the k-value by 50 pci. We recommend that the aggregate base materials be free of bituminous. In addition to improving the modulus of subgrade reaction, an aggregate base facilitates construction activities and is less weather sensitive.

C.6.b. Moisture Vapor Protection

Excess transmission of water vapor could cause floor dampness, certain types of floor bonding agents to separate, or mold to form under floor coverings. If project planning includes using floor coverings or coatings, we recommend placing a vapor retarder or vapor barrier immediately beneath the slab. We

also recommend consulting with floor covering manufacturers regarding the appropriate type, use and installation of the vapor retarder or barrier to preserve warranty assurances.

C.7. Frost Protection

We consider the onsite mixed fill soils to be moderately frost susceptible. While the proposed construction will remove the majority of these soils, unfavorable amounts of heaving could occur if these soils become saturated and freeze. Grading to direct surface drainage away from buildings helps limit the potential for saturation and subsequent heaving to occur in exterior slab areas (i.e., sidewalks or entrances). Still, even limited amounts of movement can create tripping hazards.

One method to help limit the potential for heaving to occur is to remove frost-susceptible soils present below the overlying slab area down to bottom-of-footing grades, and replace the excavated material with non-frost-susceptible, engineered fill. We recommend providing drainage at the base of the subcut, as well as gradual transitions from this subcut (3H:1V or flatter gradient).

Figure 4 shows an illustration summarizing some of the recommendations above.

Figure 4. Frost Protection Geometry Illustration

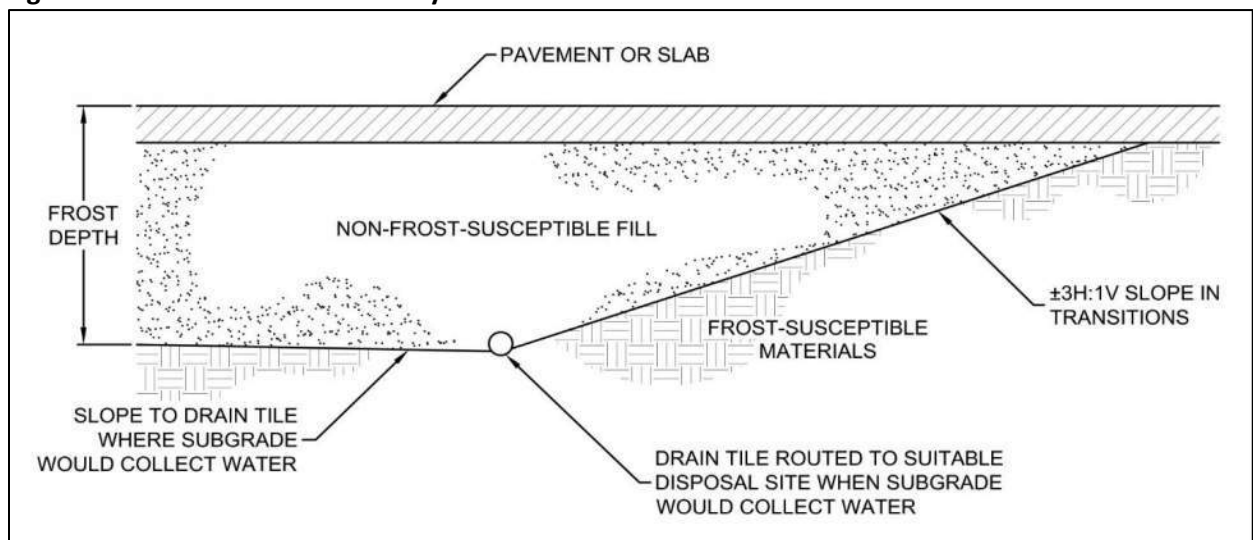

An alternative method to reduce the risk of heaving is to support the slabs on frost-depth footings, and suspend the slabs at least 4 inches above the underlying subgrade soils. With this alternative, we recommend making accommodations for differential frost heave at transition areas.

Over the life of the slab, cracks may develop and joints may open up, which will expose the subgrade and allow water to enter the subgrade. This water entering the subgrade increases the likelihood of heave. It will be critical that the owner develop a detailed maintenance program to repair any cracks and joints that may develop during the useful life of the various surface features. The maintenance program should pay special attention to areas where dissimilar materials abut one another, where construction joints occur and where shrinkage cracks develop.

C.8. Pavements

C.8.a. Pavement Subgrade Preparation

We recommend the following steps for pavement subgrade preparation. Note that project planning may need to require additional subcuts to limit frost heave.

- Strip any unsuitable soils consisting of topsoil, organic soils, vegetation, from the pavement subgrade area.
- Have a geotechnical representative observe the excavated subgrade to evaluate if additional subgrade improvements are necessary. Based on the mixed composition of the existing fill, the contractor should anticipate some additional subcuts will be needed to remove unstable soils. Where needed, subcuts would extend to depths of about 2 feet below subgrade.
- Slope subgrade soils to allow the removal of accumulating water.
- Surface compact the subgrade with several passes of a large self-propelled vibratory, drum roller.
- Place pavement engineered fill to grade and compact in accordance with Section C.2.g. to bottom of pavement and exterior slab section. See Section C.7. for additional considerations related to frost heave.
- Proofroll the pavement subgrade as described in Section C.2.f.

C.8.b. Pavement Subgrade Proofroll

After preparing the subgrade as described above and prior to the placement of the aggregate base, we recommend proofrolling the subgrade soils with a fully loaded tandem-axle truck. We also recommend having a geotechnical representative observe the proofroll. Areas that fail the proofroll likely indicate soft or weak areas that will require additional soil correction work to support pavements.

The contractor should correct areas that display excessive yielding or rutting during the proofroll, as determined by the geotechnical representative. Possible options for subgrade correction include moisture conditioning and recompaction, subcutting and replacement with sand or additional crushed aggregate, chemical stabilization and/or geotextiles. We recommend performing a second proofroll after the aggregate base material is in place, and prior to placing bituminous or concrete pavement.

C.8.c. Design Sections

Our scope of services for this project did not include laboratory tests on subgrade soils to determine an R-value for pavement design. Based on our experience with similar mixed soils anticipated at the pavement subgrade elevation, we recommend pavement design assume a Hveem Stabilometer R-value of 12. Note the contractor may need to perform limited removal of unsuitable or less suitable soils to achieve this value. Table 10 provides recommended minimum pavement sections, based on the soils supporting and the assumed traffic loads.

Table 10. Recommended Minimum Bituminous Pavement Sections

Use	Light Duty	Heavy Duty
Minimum bituminous thickness (inches)	3 1/2	4
Minimum aggregate base thickness (inches)	6	8

C.8.d. Bituminous Pavement Materials

Appropriate mix designs are critical to the performance of flexible pavements. We can provide recommendations for pavement material selection during final pavement design.

C.8.e. Concrete Pavements

Where concrete pavements are needed, we recommend they consist of a minimum 5 inches of portland concrete overlying 6 inches of crushed aggregate base course.

C.8.f. Subgrade Drainage

We recommend installing perforated drainpipes throughout pavement areas at low points, around catch basins, and behind curb in landscaped areas. We also recommend installing drainpipes along pavement and exterior slab edges where exterior grades promote drainage toward those edge areas. The contractor should place drainpipes in small trenches, extended below the aggregate base material where no subbase is present.

C.8.g. Performance and Maintenance

We based the above pavement designs on a 20-year performance. This is the amount of time before we anticipate the pavement will require reconstruction. This performance life assumes routine maintenance, such as seal coating and crack sealing. The actual pavement life will vary depending on variations in weather, traffic conditions and maintenance.

It is common to place the non-wear course of bituminous and then delay placement of wear course. For this situation, we recommend evaluating if the reduced pavement section will have sufficient structure to support construction traffic.

Many conditions affect the overall performance of the pavements. Some of these conditions include the environment, loading conditions and the level of ongoing maintenance. With regard to bituminous pavements in particular, it is common to have thermal cracking develop within the first few years of placement, and continue throughout the life of the pavement. We recommend developing a regular maintenance plan for filling cracks in pavements to lessen the potential impacts for cold weather distress due to frost heave or warm weather distress due to wetting and softening of the subgrade.

C.9. Utilities

C.9.a. Subgrade Stabilization

Earthwork activities associated with utility installations located inside the building area should adhere to the recommendations in Section C.2.g.

For exterior utilities, we anticipate the soils at typical invert elevations will be suitable for utility support. However, if construction encounters unfavorable conditions such as soft clay, organic soils or perched water at invert grades, the unsuitable soils may require some additional subcutting and replacement with sand or crushed rock to prepare a proper subgrade for pipe support.

Project design and construction should not place utilities within the 1H:1V oversizing of foundations.

C.9.b. Utility Trench Backfill

We recommend the backfilling of utility trenches adhere to the recommendations provided in Section C.2.e. depending on what overlies the trench. The contractor should anticipate moisture conditioning of soil to achieve adequate compaction especially within confined excavations.

C.9.c. Corrosion Potential

A majority of the soil borings indicated the site predominantly consists of sandy soils. We consider these soils non- to slightly corrosive to metallic conduits. If utilities extend through clay soils, we recommend bedding the utilities in sand or gravel or constructing the utilities with non-corrosive materials.

C.10. Stormwater

We anticipate that stormwater management structures will be included as part of construction. Given the mixed composition of the existing fill soils, they are not conducive to rapid infiltration of water into the subgrade. The mixed existing fill soils can be considered as Hydrologic Soil Group D in accordance with the Minnesota Stormwater Manual with an infiltration rate of 0.06 inches per second. Thus, consider designing stormwater systems as filtration rather than infiltration.

C.11. Equipment Support

The recommendations included in the report may not be applicable to equipment used for the construction and maintenance of this project. We recommend evaluating subgrade conditions in areas of shoring, scaffolding, cranes, pumps, lifts and other construction equipment prior to mobilization to determine if the exposed materials are suitable for equipment support, or require some form of subgrade improvement. We also recommend project planning consider the effect that loads applied by such equipment may have on structures they bear on or surcharge – including pavements, buried utilities, below-grade walls, etc. We can assist you in this evaluation.

D. Procedures

D.1. Penetration Test Borings

We drilled the penetration test borings with a truck-mounted auger drill equipped with hollow-stem auger. We performed the borings in general accordance with ASTM D6151 taking penetration test samples at 2 1/2- or 5-foot intervals in general accordance to ASTM D1586. We collected thin-walled tube samples in general accordance with ASTM D1587 at selected depths. The boring logs show the actual sample intervals and corresponding depths.

We sealed penetration test boreholes meeting the Minnesota Department of Health (MDH) Environmental Borehole in general accordance with MDH procedures.

D.2. Exploration Logs

D.2.a. Log of Boring Sheets

The Appendix includes Log of Boring sheets for our penetration test borings. The logs identify and describe the penetrated geologic materials, and present the results of penetration resistance and other in-situ tests performed. The logs also present the results of laboratory tests performed on penetration test samples, and groundwater measurements.

We inferred strata boundaries from changes in the penetration test samples and the auger cuttings. Because we did not perform continuous sampling, the strata boundary depths are only approximate. The boundary depths likely vary away from the boring locations, and the boundaries themselves may occur as gradual rather than abrupt transitions.

D.2.b. Geologic Origins

We assigned geologic origins to the materials shown on the logs and referenced within this report, based on: (1) a review of the background information and reference documents cited above, (2) visual classification of the various geologic material samples retrieved during the course of our subsurface exploration, (3) penetration resistance and other in-situ testing performed for the project, (4) laboratory test results, and (5) available common knowledge of the geologic processes and environments that have impacted the site and surrounding area in the past.

D.3. Material Classification and Testing

D.3.a. Visual and Manual Classification

We visually and manually classified the geologic materials encountered based on ASTM D2488. When we performed laboratory classification tests, we used the results to classify the geologic materials in accordance with ASTM D2487. The Appendix includes a chart explaining the classification system we used.

D.3.b. Laboratory Testing

The exploration logs in the Appendix note most of the results of the laboratory tests performed on geologic material samples. The remaining laboratory test results follow the exploration logs. We performed the tests in general accordance with ASTM procedures.

D.4. Groundwater Measurements

The drillers checked for groundwater while advancing the penetration test borings, and again after auger withdrawal. We then filled the boreholes or allowed them to remain open for an extended period of observation, as noted on the boring logs.

E. Qualifications

E.1. Variations in Subsurface Conditions

E.1.a. Material Strata

We developed our evaluation, analyses and recommendations from a limited amount of site and subsurface information. It is not standard engineering practice to retrieve material samples from exploration locations continuously with depth. Therefore, we must infer strata boundaries and thicknesses to some extent. Strata boundaries may also be gradual transitions, and project planning should expect the strata to vary in depth, elevation and thickness, away from the exploration locations.

Variations in subsurface conditions present between exploration locations may not be revealed until performing additional exploration work, or starting construction. If future activity for this project reveals any such variations, you should notify us so that we may reevaluate our recommendations. Such variations could increase construction costs, and we recommend including a contingency to accommodate them.

E.1.b. Groundwater Levels

We made groundwater measurements under the conditions reported herein and shown on the exploration logs, and interpreted in the text of this report. Note that the observation periods were relatively short, and project planning can expect groundwater levels to fluctuate in response to rainfall, flooding, irrigation, seasonal freezing and thawing, surface drainage modifications and other seasonal and annual factors.

E.2. Continuity of Professional Responsibility

E.2.a. Plan Review

We based this report on a limited amount of information, and we made a number of assumptions to help us develop our recommendations. We should be retained to review the geotechnical aspects of the designs and specifications. This review will allow us to evaluate whether we anticipated the design correctly, if any design changes affect the validity of our recommendations, and if the design and specifications correctly interpret and implement our recommendations.

E.2.b. Construction Observations and Testing

We recommend retaining us to perform the required observations and testing during construction as part of the ongoing geotechnical evaluation. This will allow us to correlate the subsurface conditions exposed during construction with those encountered by the borings and provide professional continuity from the design phase to the construction phase. If we do not perform observations and testing during construction, it becomes the responsibility of others to validate the assumption made during the preparation of this report and to accept the construction-related geotechnical engineer-of-record responsibilities.

E.3. Use of Report

This report is for the exclusive use of the addressed parties. Without written approval, we assume no responsibility to other parties regarding this report. Our evaluation, analyses and recommendations may not be appropriate for other parties or projects.

E.4. Standard of Care

In performing its services, Braun Intertec used that degree of care and skill ordinarily exercised under similar circumstances by reputable members of its profession currently practicing in the same locality. No warranty, express or implied, is made.

Appendix

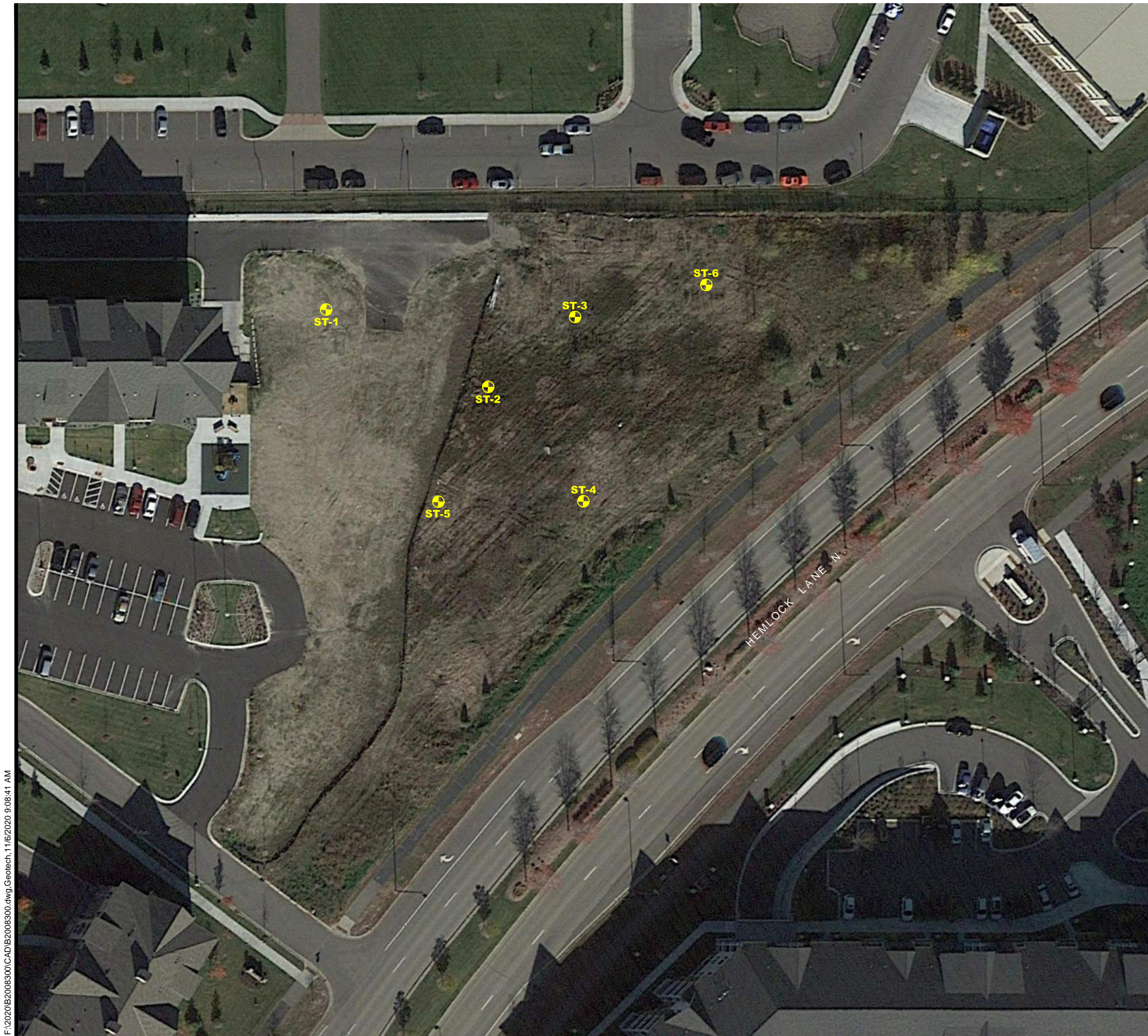

F:\2020\B2008300\CAD\B2008300.dwg, Geotech, 11/16/2020 9:08:41 AM

 DENOTES APPROXIMATE LOCATION OF STANDARD PENETRATION TEST BORING

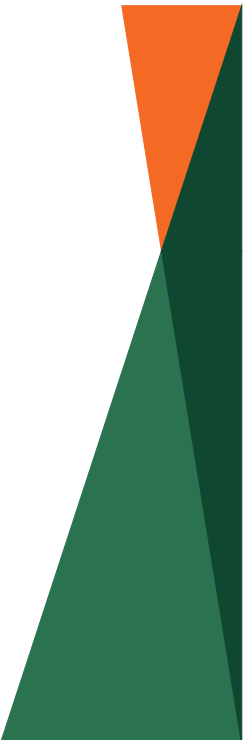
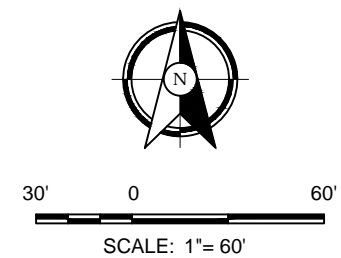

Drawing Information

Project No:
B2008300

Drawing No:
B2008300

Drawn By: JAG
Date Drawn: 9/22/20
Checked By: AB
Last Modified: 11/6/20

Project Information

Bottineau Ridge Phase III

11875 80th Avenue N.

Maple Grove, Minnesota

**Soil Boring
Location Sketch**

Project Number B2008300				BORING: ST-1	
Geotechnical Evaluation				LOCATION: See attached sketch	
Bottineau Ridge Phase III				NORTHING: 212624 EASTING: 487866	
11875 80th Avenue North				START DATE: 09/29/20 END DATE: 09/29/20	
Maple Grove, Minnesota				SURFACING: Grass WEATHER: Cloudy	
DRILLER: M. Takada		LOGGED BY: A. Bizal			
SURFACE ELEVATION: 903.9 ft		RIG: 7504		METHOD: 3 1/4" HSA	

Elev./Depth ft	Water Level	Description of Materials (Soil-ASTM D2488 or 2487; Rock-USACE EM 1110-1-2908)	Sample	Blows (N-Value) Recovery	q _p tsf	MC %	Tests or Remarks	
903.4		SILTY SAND (SM), fine to coarse-grained, brown, dry (TOPSOIL) FILL: POORLY GRADED SAND (SP), with Gravel, brick debris, brown, dry		14-22-21 (43) 14"				
0.5			5	9-16-20 (36) 6"				
					6-13-15 (28) 8"			
894.4			POORLY GRADED SAND (SP), fine to coarse-grained, with Gravel, brown, moist to wet, medium dense to dense (GLACIAL OUTWASH)	10	10-12-16 (28) 6"		1	
9.5					3-13-20 (33) 10"			
				15	7-10-14 (24) 8"			
				20	6-12-21 (33) 20"			
		Wet at 15 feet		23-2-7 (9) 18"				
879.4		END OF BORING	25				Water observed at 15.0 feet while drilling.	
24.5		Boring immediately backfilled with bentonite grout						
			30					

Project Number B2008300				BORING: ST-2			
Geotechnical Evaluation				LOCATION: See attached sketch			
Bottineau Ridge Phase III				NORTHING: 212578 EASTING: 487964			
11875 80th Avenue North				START DATE: 09/29/20 END DATE: 09/29/20			
Maple Grove, Minnesota				SURFACING: Grass WEATHER: Cloudy			
DRILLER: M. Takada		LOGGED BY: A. Bizal					
SURFACE ELEVATION: 904.9 ft	RIG: 7504	METHOD: 3 1/4" HSA					
Elev./ Depth ft	Water Level	Description of Materials (Soil-ASTM D2488 or 2487; Rock-USACE EM 1110-1-2908)	Sample	Blows (N-Value) Recovery	q _p tsf	MC %	Tests or Remarks
904.4 0.5		SILTY SAND (SM), fine-grained, trace roots, black, dry (TOPSOIL) FILL: POORLY GRADED SAND (SP), fine to coarse-grained, with Gravel, brown, dry		6-12-9 (21) 8"			
			5	20-21-25 (46) 3"			
				21-24-50/5" (REF) 12"		6	P200=31%
			10	12-21-50/5" (REF) 4"		2	
892.9 12.0		POORLY GRADED SAND (SP), with Gravel, brown, moist, medium dense to very loose (GLACIAL OUTWASH)		7-7-7 (14) 10"		3	
		<i>Wet at 15 feet</i>	15	6-7-9 (16) 12"			
			20	1-2-1 (3) 16"			
				2-2-3 (5) 14"			
880.4 24.5		END OF BORING	25				Water observed at 15.0 feet while drilling.
		Boring immediately backfilled with bentonite grout					
			30				

See Descriptive Terminology sheet for explanation of abbreviations

Project Number B2008300					BORING: ST-3		
Geotechnical Evaluation					LOCATION: See attached sketch		
Bottineau Ridge Phase III					NORTHING: 212620 EASTING: 488016		
11875 80th Avenue North					START DATE: 09/29/20 END DATE: 09/29/20		
Maple Grove, Minnesota					SURFACING: Grass WEATHER: Cloudy		
DRILLER: M. Takada		LOGGED BY: A. Bizal		SURFACE ELEVATION: 905.3 ft		RIG: 7504	METHOD: 3 1/4" HSA
Elev./Depth ft	Water Level	Description of Materials (Soil-ASTM D2488 or 2487; Rock-USACE EM 1110-1-2908)	Sample	Blows (N-Value) Recovery	q _p tsf	MC %	Tests or Remarks
904.8		SILT (ML), black, dry (TOPSOIL)					
0.5		FILL: POORLY GRADED SAND (SP), fine to medium-grained, with Gravel, brown, dry		20-21-50/3" (REF) 1"			
901.3							
4.0		POORLY GRADED SAND with SILT (SP-SM), fine to coarse-grained, with Gravel, brown, dry	5	14-20-19 (39) 16"		3	P200=10%
898.3							
7.0		SANDY LEAN CLAY (CL), trace Gravel, brown, moist		7-4-4 (8) 4"		20	
896.3							
9.0		FILL: CLAYEY SAND (SC), trace Gravel, brown, moist	10	3-4-4 (8) 3"		12	
891.3				8-10-11 (21) 12"			
14.0		POORLY GRADED SAND with SILT (SP-SM), fine to coarse-grained, trace, brown, moist, medium dense (GLACIAL OUTWASH)	15	9-10-12 (22) 16"			
886.3							
19.0		POORLY GRADED SAND (SP), fine to medium-grained, trace Gravel, brown, wet, very loose to medium dense (GLACIAL OUTWASH)	20	1-1-1 (2) 18"			Wet at 21 feet
880.8							
24.5		END OF BORING	25	9-13-14 (27) 14"			Water observed at 21.0 feet while drilling.
		Boring immediately backfilled with bentonite grout					
			30				

See Descriptive Terminology sheet for explanation of abbreviations

Project Number B2008300				BORING: ST-4			
Geotechnical Evaluation				LOCATION: See attached sketch			
Bottineau Ridge Phase III				NORTHING: 212509	EASTING: 488021		
11875 80th Avenue North				START DATE: 09/29/20	END DATE: 09/29/20		
Maple Grove, Minnesota				SURFACING: Grass	WEATHER: Cloudy		
DRILLER: M. Takada	LOGGED BY: A. Bizal	SURFACE ELEVATION: 906.1 ft		RIG: 7504	METHOD: 3 1/4" HSA		
Elev./ Depth ft	Water Level	Description of Materials (Soil-ASTM D2488 or 2487; Rock-USACE EM 1110-1-2908)	Sample	Blows (N-Value) Recovery	q _p tsf	MC %	Tests or Remarks
905.6 0.5		SILTY SAND (SM), fine-grained, dark brown, dry (TOPSOIL) FILL: CLAYEY SAND (SC), with Silty Sand, with Gravel, brown gray, dry		6-8-10 (18) 20"			
			5	10-14-11 (25) 16"			
				7-11-12 (23) 18"		9	
			10	10-11-12 (23) 16"		9	P200=36%
				7-7-9 (16) 18"		11	
890.1 16.0		POORLY GRADED SAND (SP), fine to coarse-grained, with Gravel, brown, wet, medium dense to loose (GLACIAL OUTWASH)		10-22-50/4" (REF) 10"		7	Wet at 16 feet
881.6 24.5		END OF BORING	25	2-9-10 (19) 8"			
		Boring immediately backfilled with bentonite grout		3-2-3 (5) 18"			
			30				

Criteria for Assigning Group Symbols and Group Names Using Laboratory Tests ^A			Soil Classification		
			Group Symbol	Group Name ^B	
Coarse-grained Soils (more than 50% retained on No. 200 sieve)	Gravels (More than 50% of coarse fraction retained on No. 4 sieve)	Clean Gravels (Less than 5% fines ^C)	$C_u \geq 4$ and $1 \leq C_c \leq 3^D$	GW	Well-graded gravel ^E
		Gravels with Fines (More than 12% fines ^C)	$C_u < 4$ and/or ($C_c < 1$ or $C_c > 3$) ^D	GP	Poorly graded gravel ^E
			Fines classify as ML or MH	GM	Silty gravel ^{EFG}
	Sands (50% or more coarse fraction passes No. 4 sieve)	Clean Sands (Less than 5% fines ^H)	$C_u \geq 6$ and $1 \leq C_c \leq 3^D$	SW	Well-graded sand ^I
		Sands with Fines (More than 12% fines ^H)	$C_u < 6$ and/or ($C_c < 1$ or $C_c > 3$) ^D	SP	Poorly graded sand ^I
			Fines classify as ML or MH	SM	Silty sand ^{FGI}
	Fines classify as CL or CH	SC	Clayey sand ^{FGI}		
Fine-grained Soils (50% or more passes the No. 200 sieve)	Silt and Clays (Liquid limit less than 50)	Inorganic	PI > 7 and plots on or above "A" line ^J	CL	Lean clay ^{KLM}
			PI < 4 or plots below "A" line ^J	ML	Silt ^{KLM}
	Silt and Clays (Liquid limit 50 or more)	Inorganic	PI plots on or above "A" line	CH	Fat clay ^{KLM}
			PI plots below "A" line	MH	Elastic silt ^{KLM}
		Organic	Liquid Limit – oven dried < 0.75	OL	Organic clay ^{KLMN} Organic silt ^{KLMO}
	Liquid Limit – not dried < 0.75		OH	Organic clay ^{KLMP} Organic silt ^{KLMQ}	
Highly Organic Soils	Primarily organic matter, dark in color, and organic odor		PT	Peat	

- A. Based on the material passing the 3-inch (75-mm) sieve.
- B. If field sample contained cobbles or boulders, or both, add "with cobbles or boulders, or both" to group name.
- C. Gravels with 5 to 12% fines require dual symbols:
GW-GM well-graded gravel with silt
GW-GC well-graded gravel with clay
GP-GM poorly graded gravel with silt
GP-GC poorly graded gravel with clay
- D. $C_u = D_{60} / D_{10}$ $C_c = (D_{30})^2 / (D_{10} \times D_{60})$
- E. If soil contains $\geq 15\%$ sand, add "with sand" to group name.
- F. If fines classify as CL-ML, use dual symbol GC-GM or SC-SM.
- G. If fines are organic, add "with organic fines" to group name.
- H. Sands with 5 to 12% fines require dual symbols:
SW-SM well-graded sand with silt
SW-SC well-graded sand with clay
SP-SM poorly graded sand with silt
SP-SC poorly graded sand with clay
- I. If soil contains $\geq 15\%$ gravel, add "with gravel" to group name.
- J. If Atterberg limits plot in hatched area, soil is CL-ML, silty clay.
- K. If soil contains 15 to < 30% plus No. 200, add "with sand" or "with gravel", whichever is predominant.
- L. If soil contains $\geq 30\%$ plus No. 200, predominantly sand, add "sandy" to group name.
- M. If soil contains $\geq 30\%$ plus No. 200 predominantly gravel, add "gravelly" to group name.
- N. PI ≥ 4 and plots on or above "A" line.
- O. PI < 4 or plots below "A" line.
- P. PI plots on or above "A" line.
- Q. PI plots below "A" line.

Particle Size Identification

Boulders..... over 12"
Cobbles..... 3" to 12"
Gravel
 Coarse..... 3/4" to 3" (19.00 mm to 75.00 mm)
 Fine..... No. 4 to 3/4" (4.75 mm to 19.00 mm)
Sand
 Coarse..... No. 10 to No. 4 (2.00 mm to 4.75 mm)
 Medium..... No. 40 to No. 10 (0.425 mm to 2.00 mm)
 Fine..... No. 200 to No. 40 (0.075 mm to 0.425 mm)
Silt..... No. 200 (0.075 mm) to .005 mm
Clay..... < .005 mm

Relative Proportions^{L, M}

trace..... 0 to 5%
little..... 6 to 14%
with..... $\geq 15\%$

Inclusion Thicknesses

lens..... 0 to 1/8"
seam..... 1/8" to 1"
layer..... over 1"

Apparent Relative Density of Cohesionless Soils

Very loose 0 to 4 BPF
Loose 5 to 10 BPF
Medium dense..... 11 to 30 BPF
Dense..... 31 to 50 BPF
Very dense..... over 50 BPF

Consistency of Cohesive Soils Blows Per Foot Approximate Unconfined Compressive Strength

Very soft..... 0 to 1 BPF..... < 0.25 tsf
Soft..... 2 to 4 BPF..... 0.25 to 0.5 tsf
Medium..... 5 to 8 BPF..... 0.5 to 1 tsf
Stiff..... 9 to 15 BPF..... 1 to 2 tsf
Very Stiff..... 16 to 30 BPF..... 2 to 4 tsf
Hard..... over 30 BPF..... > 4 tsf

Moisture Content:

Dry: Absence of moisture, dusty, dry to the touch.
Moist: Damp but no visible water.
Wet: Visible free water, usually soil is below water table.

Drilling Notes:

Blows/N-value: Blows indicate the driving resistance recorded for each 6-inch interval. The reported N-value is the blows per foot recorded by summing the second and third interval in accordance with the Standard Penetration Test, ASTM D1586.

Partial Penetration: If the sampler could not be driven through a full 6-inch interval, the number of blows for that partial penetration is shown as #/x" (i.e. 50/2"). The N-value is reported as "REF" indicating refusal.

Recovery: Indicates the inches of sample recovered from the sampled interval. For a standard penetration test, full recovery is 18", and is 24" for a thinwall/shelby tube sample.

WOH: Indicates the sampler penetrated soil under weight of hammer and rods alone; driving not required.

WOR: Indicates the sampler penetrated soil under weight of rods alone; hammer weight and driving not required.

Water Level: Indicates the water level measured by the drillers either while drilling (∇), at the end of drilling (\blacktriangledown), or at some time after drilling (\blacktriangledown).

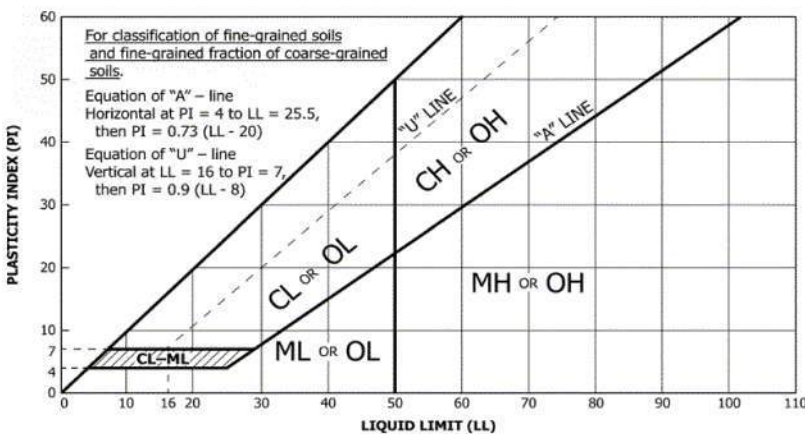

Laboratory Tests			
DD	Dry density, pcf	OC	Organic content, %
WD	Wet density, pcf	q _p	Pocket penetrometer strength, tsf
P200	% Passing #200 sieve	MC	Moisture content, %
		q _u	Unconfined compression test, tsf
		LL	Liquid limit
		PL	Plastic limit
		PI	Plasticity index

Multifamily - Intended Methods Worksheet

2019 MN Overlay to the 2015 Enterprise Green Communities Criteria

Project Name: Bottineau Ridge III	Submittal Phase:		Construction Type:	
Location (City): Maple Grove	<input checked="" type="checkbox"/> Application	<input checked="" type="checkbox"/> New Construction	<input type="checkbox"/> Loan Commitment/ Loan Closing	<input type="checkbox"/> Substantial/ Gut Rehab
Developer/Owner/Borrower: Duffy Development Company, Inc.	<input type="checkbox"/> End of Construction/ Construction Close-out	<input type="checkbox"/> Moderate Rehab		
Architect of Record: Cole Group Architects, LLC				
General Contractor: To be determined				
HERS Rater/Energy Consult (Person & Entity): The Element Group				
This Form Prepared By (Person & Entity): Jeff Von Feldt, Duffy Development				
Date Last Updated:				

- Multifamily New Construction projects must include all applicable "Mandatory" Criteria and at least (35) Optional Criteria points.
- Multifamily Substantial/Gut Rehab and Moderate Rehab projects must include all applicable "Mandatory" Criteria and at least (30) Optional Criteria points.
- Adaptive Reuse projects must follow either Substantial or Moderate Rehab Mandatory and selected Optional Criteria requirements.
- The information on this form must reference and reconcile with the 2015 Enterprise Green Communities Criteria as amended with the current/applicable version of the MN Overlay.
- For developments with scattered sites, different construction types or a combination of low-rise and mid/high-rise buildings - a separate Intended Methods Worksheet form must be provided.
- Items with text in red as such are MN Overlay items.
- The "How Will Criteria Be Implemented?....." column must be completed for all Mandatory and selected Optional Criteria points. Provide a detailed description.
- This document is formatted to be printed in a landscape (horizontal) letter (11" x 8.5") page format.
- Key to Column Headers: # = Criteria Number; M/O = Mandatory Criteria or Optional Criteria Points; N/A = Not Applicable; WR = Waiver Request; OP = Selected Optional Points
- All documents referenced herein are available at the Minnesota Housing [Building Standards](#) webpage.

Key to Column Headers:

= Criteria Number, M/O = Mandatory Criteria or Optional Criteria Points,
 N/A = Not Applicable, WR = Waiver Request, OP = Selected Optional Points

C#	M/O	Criteria Title	Criteria Description	How Will Criteria Be Implemented? And, where in the plans, specifications, or other place will compliance be documented?	Intent to Comply				
					Yes	No	N/A	WR	OP

1. Integrative Design Category

1.1a	M	Goal Setting (Mandatory for all)	Develop an integrative design process that works best for your project team and intentions. At minimum, document: 1. A statement of the overall green development goals of the project and the expected intended outcomes from addressing those goals. 2. A summary of the integrative process that was used to select the green building strategies, systems and materials that will be incorporated into the project. 3. A description of how progress and success against these goals will be measured throughout the completion of design, construction and operation to ensure that the green features are included and correctly installed.	Meetings will be held between owner, Cole Group Architects and The Element Group in regard to efficiency design elements. Options to consider and goals will be developed and implemented depending on cost/benefit analysis.	<input checked="" type="checkbox"/>	<input type="checkbox"/>	<input type="checkbox"/>	<input type="checkbox"/>	
1.1b	M	Criteria Documentation (Mandatory for all)	Create design and construction documentation to include information on implementation of appropriate Enterprise Green Communities Criteria.	Cole Group Architects will incorporate in plans and specs.	<input checked="" type="checkbox"/>	<input type="checkbox"/>	<input type="checkbox"/>	<input type="checkbox"/>	
1.1c	9	Designing for Project Performance	Identify how the expected performance of your project compares to the actual performance of other projects in your portfolio and/or community.		<input type="checkbox"/>	<input checked="" type="checkbox"/>	<input type="checkbox"/>	<input type="checkbox"/>	0
1.2a	M or 2	Resident Health and Wellbeing: Design for Health (Mandatory for NC) (2 optional points for Sub/Gut and Mod Rehab)	Identify potential resident health factors, and design your project to address resident health and well-being by using the matrix provided on pages 22 and 23 of the 2015 EGCC document.	A review of the appropriate sections will be done and incorporated into the plans and specs where appropriate.	<input checked="" type="checkbox"/>	<input type="checkbox"/>	<input type="checkbox"/>	<input type="checkbox"/>	0

Key to Column Headers:

C# = Criteria Number, M/O = Mandatory Criterion or Optional Criteria Points,
N/A = Not Applicable, WR = Waiver Request, OP = Selected Optional Points

C#	M/O	Criteria Title	Criteria Description	How Will Criteria Be Implemented? And, where in the plans, specifications, or other place will compliance be documented?	Intent to Comply					
					Yes	No	N/A	WR	OP	
1.2b	12	Resident Health and Wellbeing: Health Action Plan	At pre-design and continuing throughout the project life cycle, collaborate with public health professionals and community stakeholders to assess, identify, implement and monitor achievable actions to enhance health-promoting features of the project and minimize features that could present health risks. Specifically, create a Health Action Plan and integrate the selected interventions and a plan for monitoring and evaluating progress per the full criterion.		<input type="checkbox"/>	<input checked="" type="checkbox"/>	<input type="checkbox"/>	<input type="checkbox"/>	<input type="checkbox"/>	0
1.3a	M	Resilient Communities: Design for Resilience (Mandatory for NC and Sub/Gut Rehab only)	Given your project building type, location and expected resident population, identify a project characteristic that would most likely impact your project's ability to withstand an unexpected weather event or loss of power. Select at least one criterion from the given list that would help mitigate that impact, and incorporate this within your project plans and design. Include a short narrative providing your rationale for selecting this criterion above the others.	We will utilize the Enterprise Multifamily Resilience Manual to determine the most appropriate way to accomplish this goal based on the housing design.	<input checked="" type="checkbox"/>	<input type="checkbox"/>	<input type="checkbox"/>	<input type="checkbox"/>	<input type="checkbox"/>	0
1.3b	15	Resilient Communities: Multi-Hazard Risk/Vulnerability Assessment	Carry out a Vulnerabilities Assessment, and implement building elements designed to enable the project to adapt to, and mitigate, climate impacts given the project location, building/construction type and resident population.		<input type="checkbox"/>	<input checked="" type="checkbox"/>	<input type="checkbox"/>	<input type="checkbox"/>	<input type="checkbox"/>	0
Subtotal Category 1 Selected Optional Points										0

Key to Column Headers:
 C# = Criteria Number, M/O = Mandatory Criterion or Optional Criteria Points,
 N/A = Not Applicable, WR = Waiver Request, OP = Selected Optional Points

C#	M/O	Criteria Title	Criteria Description	How Will Criteria Be Implemented? And, where in the plans, specifications, or other place will compliance be documented?	Intent to Comply				
					Yes	No	N/A	WR	OP

2. Location + Neighborhood Fabric Category

Criteria 2 Overlay - New Construction (NC) projects *are not required to earn optional points under Criterion 2.8 Access to Public Transportation, NOR are they required to earn 8 optional points through selecting one or more of the following: Criterion 2.7, 2.9, 2.12, 2.13, or 2.14.*

2.1	M	Sensitive Site Selection (Mandatory for NC only)	Do not locate new projects, including buildings, built structures, roads or parking areas, on portions of sites that meet any of the following provisions: 1. Wetland setbacks shall be per local and regional watershed requirements, ordinances, etc. 2. Land on slope greater than 15% 3. Land with prime soils, unique soils or soils of state significance per USDA designations 4. Public parkland 5. Land that is specifically identified as an existing habitat for any species on federal or state threatened or endangered lists 6. Land that is within the Special Flood Hazard Areas (SFHA) as identified by FEMA on the Flood Insurance Rate Map	The site is a former gravel mining area. No issues exist relating to this criteria.	<input checked="" type="checkbox"/>	<input type="checkbox"/>	<input type="checkbox"/>	<input type="checkbox"/>	<input type="checkbox"/>
2.2	M	Connections to Existing Development and Infrastructure (Mandatory for NC only) (refer to criteria for other exceptions)	Locate the project on a site with access to existing roads, water, sewers and other infrastructure within or contiguous to (having at least 25% of the perimeter bordering) existing development. Connect the project to the pedestrian grid.	Located in a fully developed area of the City	<input checked="" type="checkbox"/>	<input type="checkbox"/>	<input type="checkbox"/>	<input type="checkbox"/>	<input type="checkbox"/>
2.3	M	Compact Development (Mandatory for NC only)	At a minimum, build to the residential density (dwelling units/acre) of the census block group in which your project is located.	The residential density of the census tract is 2.65 hns/acre. This development will exceed the density.	<input checked="" type="checkbox"/>	<input type="checkbox"/>	<input type="checkbox"/>	<input type="checkbox"/>	<input type="checkbox"/>
2.4	5 or 7	Compact Development	Exceed the residential density (dwelling units/acre) of the census block group in which your project is located. Exceed by 2x for [5 points]; exceed by 3x for [7 points].	The development will exceed the density by more than three times the census density of 2.65. Density of this site is close to 20 units/acre.	<input checked="" type="checkbox"/>	<input type="checkbox"/>	<input type="checkbox"/>	<input type="checkbox"/>	7
2.5	M	Proximity to Services (Mandatory for NC only)	Locate the project within a 0.5-mile walk distance of at least four, or a 1-mile walk distance of at least seven, of the listed services. For projects that qualify as Rural/Tribal/Small Town, locate the project within 5 miles of at least four of the listed services.	Development is within .5 miles of food stores, clothing stores, banks, child care and public parks.	<input checked="" type="checkbox"/>	<input type="checkbox"/>	<input type="checkbox"/>	<input type="checkbox"/>	<input type="checkbox"/>

Key to Column Headers:

C# = Criteria Number, M/O = Mandatory Criteria or Optional Criteria Points, N/A = Not Applicable, WR = Waiver Request, OP = Selected Optional Points

C#	M/O	Criteria Title	Criteria Description	How Will Criteria Be Implemented? And, where in the plans, specifications, or other place will compliance be documented?	Intent to Comply				
					Yes	No	N/A	WR	OP
2.6	M	Preservation of and Access to Open Space for Rural/Tribal/Small Towns (Mandatory for applicable NC only)	Set aside a minimum of 10% (minimum of 0.25 acre) of the total project acreage as non-paved open space for use by all residents OR locate the project within a 0.25-mile walk distance of dedicated public non-paved open space that is a minimum of 0.75 acres.		<input type="checkbox"/>	<input type="checkbox"/>	<input checked="" type="checkbox"/>	<input type="checkbox"/>	
2.7	2, 4, or 6	Preservation of and Access to Open Space	Set aside a percentage of non-paved open space for use by all residents. 20% [2 points]; 30% [4 points]; 40% + written statement of preservation/conservation policy for set-aside land [6 points].	Site plan will have at least 20% non-paved open space.	<input checked="" type="checkbox"/>	<input type="checkbox"/>	<input type="checkbox"/>	<input type="checkbox"/>	2
2.8	8 or 10	Access to Public Transportation	Locate projects within a 0.5-mile walk distance of transit services combined (bus, rail and/or ferry), constituting at least 60 or more transit rides per weekday, with some type of weekend ride option. [8 points]	The development site is within .5 miles of the Maple Grove Park and Ride that provides express service to Minneapolis, St. Paul and the University of Minnesota. Additionally, the site is connected by bike trails that lead to transit.	<input checked="" type="checkbox"/>	<input type="checkbox"/>	<input type="checkbox"/>	<input type="checkbox"/>	10
2.9	1 - 4	Improving Connectivity to the Community	Improve access to community amenities through at least one of the transit, auto or biking mobility measures listed.		<input type="checkbox"/>	<input checked="" type="checkbox"/>	<input type="checkbox"/>	<input type="checkbox"/>	0
2.10	5 max	Passive Solar Heating/Cooling	Design and build with passive solar design, orientation and shading that meet specified guidelines.		<input type="checkbox"/>	<input checked="" type="checkbox"/>	<input type="checkbox"/>	<input type="checkbox"/>	0
2.11	4	Brownfield Site or Adaptive Reuse Building	Rehabilitate an existing structure that was not previously used as housing, or locate the project on a brownfield site.		<input type="checkbox"/>	<input checked="" type="checkbox"/>	<input type="checkbox"/>	<input type="checkbox"/>	0

Key to Column Headers:
C# = Criteria Number, M/O = Mandatory Criterial or Optional Criteria Points,
N/A = Not Applicable, WR = Waiver Request, OP = Selected Optional Points

C#	M/O	Criteria Title	Criteria Description	How Will Criteria Be Implemented? And, where in the plans, specifications, or other place will compliance be documented?	Intent to Comply				
					Yes	No	N/A	WR	OP
2.12	6	Access to Fresh, Local Foods	Pursue one of three options to provide residents and staff with access to fresh, local foods, including neighborhood farms and gardens; community-supported agriculture; or proximity to farmers markets.		<input type="checkbox"/>	<input checked="" type="checkbox"/>	<input type="checkbox"/>	<input type="checkbox"/>	0
2.13	4	LEED for Neighborhood Development Certification	Locate building(s) in a Stage 2 Pre-Certified or Stage 3 Certified Neighborhood Development.		<input type="checkbox"/>	<input checked="" type="checkbox"/>	<input type="checkbox"/>	<input type="checkbox"/>	0
2.14	6 max	Local Economic Development and Community Wealth Creation	Demonstrate that local preference for construction employment and subcontractor hiring was part of your bidding process [2 points]; OR demonstrate that you achieved at least 20% local employment [3 points]; OR provide physical space for small business, nonprofits, and/or skills and workforce education [3 points].		<input type="checkbox"/>	<input checked="" type="checkbox"/>	<input type="checkbox"/>	<input type="checkbox"/>	0
Subtotal Category 2 Selected Optional Points									19

Key to Column Headers:

C# = Criteria Number, M/O = Mandatory Criterion or Optional Criteria Points, N/A = Not Applicable, WR = Waiver Request, OP = Selected Optional Points

C#	M/O	Criteria Title	Criteria Description	How Will Criteria Be Implemented? And, where in the plans, specifications, or other place will compliance be documented?	Intent to Comply				
					Yes	No	N/A	WR	OP

3. Site Improvements Category

3.1	M	Environmental Remediation	Refer to Minnesota Housing Environmental Standards		<input type="checkbox"/>	<input checked="" type="checkbox"/>	<input type="checkbox"/>	<input type="checkbox"/>	<input type="checkbox"/>
3.2	M	Erosion and Sedimentation Control (Mandatory for all, except for infill sites with buildable area smaller than one acre)	Implement EPA's Best Management Practices for Construction Site Stormwater Runoff Control, or local requirements, whichever is more stringent.	Will implement EPA's best management practices.	<input checked="" type="checkbox"/>	<input type="checkbox"/>	<input type="checkbox"/>	<input type="checkbox"/>	<input type="checkbox"/>
3.3	M	Low Impact Development (Mandatory only for projects located on greenfields)	Projects located on greenfields must meet the list of low-impact development criteria.		<input type="checkbox"/>	<input type="checkbox"/>	<input checked="" type="checkbox"/>	<input type="checkbox"/>	<input type="checkbox"/>
3.4	M	Landscaping (Mandatory for all)	If providing plantings, all should be native or adapted to the region, appropriate to the site's soil and microclimate, and none of the new plants should be an invasive species. Reseed or xeriscape all disturbed areas.	Will provide native plants/trees.	<input checked="" type="checkbox"/>	<input type="checkbox"/>	<input type="checkbox"/>	<input type="checkbox"/>	<input type="checkbox"/>
3.5a	M	Efficient Irrigation and Water Reuse (Mandatory if irrigation is used)	If irrigation is used, install an efficient irrigation or water reuse system per the guidelines.	Irrigation system will be efficient	<input checked="" type="checkbox"/>	<input type="checkbox"/>	<input type="checkbox"/>	<input type="checkbox"/>	<input type="checkbox"/>
3.5b	4 or 8	Efficient Irrigation and Water Reuse	Install an efficient irrigation system equipped with a WaterSense-labeled weather-based irrigation controller (WBIC) (4 points) OR at least 50% of the site's irrigation should be satisfied by reusing water (8 points).	Will specify and have installed a WaterSense-labeled weather-based irrigation controller.	<input checked="" type="checkbox"/>	<input type="checkbox"/>	<input type="checkbox"/>	<input type="checkbox"/>	<input type="checkbox"/>
3.6	4 or 8	Surface Stormwater Management	Retain, infiltrate and/or harvest the first 1.0 inch of rain that falls [4 points]; OR as calculated for a 24-hour period of a one-year (1) storm event, so that no stormwater is discharged to drains/inlets. [8 points] For both options, permanently label all storm drains and inlets.		<input type="checkbox"/>	<input checked="" type="checkbox"/>	<input type="checkbox"/>	<input type="checkbox"/>	<input type="checkbox"/>
3.7	1	Reducing Heat Island Effect: Paving	Use light-colored, high-albedo materials and/or an open-grid pavement, with a minimum solar reflectance of 0.3, over at least 50% of the site's hardscaped area.		<input type="checkbox"/>	<input checked="" type="checkbox"/>	<input type="checkbox"/>	<input type="checkbox"/>	<input type="checkbox"/>
Subtotal Category 3 Selected Optional Points					4				

Key to Column Headers:
 C# = Criteria Number, M/O = Mandatory Criterial or Optional Criteria Points,
 N/A = Not Applicable, WR = Waiver Request, OP = Selected Optional Points

C#	M/O	Criteria Title	Criteria Description	How Will Criteria Be Implemented? And, where in the plans, specifications, or other place will compliance be documented?	Intent to Comply				
					Yes	No	N/A	WR	OP

4. Water Conservation Category

4.1	M or 5 Max	Water-Conserving Fixtures (Mandatory for NC and Sub/Gut Rehab only) (Optional/5 points for Mod Rehab)	Install water-conserving fixtures in all units and any common facilities with the following specifications. Toilets: WaterSense-labeled and 1.28 gpf; Urinals: WaterSense-labeled and 0.5 gpf; Showerheads: WaterSense-labeled and 2.0 gpm; Kitchen faucets: 2.0 gpm; Lav faucets: WaterSense-labeled and 1.5 gpm; AND for all single-family homes and all dwelling units in buildings three stories or fewer, the static service pressure must not exceed 60 psi. Optional Mod Rehab points: All Toilets [1] point, All Urinals [1] point, All Showerheads [1] point, All Kitchen Faucets [1] point, and/or All Lavatory Faucets [1] point.	The design team will incorporate all required minimum water-conserving fixtures.	<input checked="" type="checkbox"/>	<input type="checkbox"/>	<input type="checkbox"/>	<input type="checkbox"/>	0
4.2	6 max	Advanced Water Conservation	Reduce water consumption either by installing water-conserving fixtures in all units and all common space bathrooms with the following specifications: Toilets: WaterSense-labeled and 1.1 gpf [1 point]; Showerheads: WaterSense-labeled and 1.5 gpm [1 point]; Kitchen faucets: 1.5 gpm and lav faucets: WaterSense-labeled and 1.0 gpm [1 point] OR Reduce total indoor water consumption by at least 30% compared to the baseline indoor water consumption chart, through a combination of your choosing. [6 points maximum]	The specifications will provide for WaterSense-labeled showerheads and lavatory faucets for 2 points.	<input checked="" type="checkbox"/>	<input type="checkbox"/>	<input type="checkbox"/>	<input type="checkbox"/>	2
4.3	4	Leaks and Water Metering	Conduct pressure-loss tests and visual inspections to determine if there are any leaks; fix any leaks found; and meter or submeter each dwelling unit with a technology capable of tracking water use. Separately meter outdoor water consumption.	The units will be submeters for hot and cold water separately. Systems will be put in place to monitor remotely and daily to address potential leaks as soon as possible.	<input checked="" type="checkbox"/>	<input type="checkbox"/>	<input type="checkbox"/>	<input type="checkbox"/>	4

Key to Column Headers:

C# = Criteria Number, M/O = Mandatory Criterion or Optional Criteria Points,
N/A = Not Applicable, WR = Waiver Request, OP = Selected Optional Points

C#	M/O	Criteria Title	Criteria Description	How Will Criteria Be Implemented? And, where in the plans, specifications, or other place will compliance be documented?	Intent to Comply				
					Yes	No	N/A	WR	OP
4.4	4	Efficient Plumbing Layout and Design	To minimize water loss from delivering hot water, the hot water delivery system shall store no more than 0.5 gallons of water in any piping/manifold between the hot water source and any hot water fixture.	<input type="checkbox"/>	<input checked="" type="checkbox"/>	<input type="checkbox"/>	<input type="checkbox"/>	<input type="checkbox"/>	0
4.5	6 max	Water Reuse	Harvest, treat, and reuse rainwater and/or greywater to meet a portion of the project's total water needs: 10% reuse [3 points]; 20% reuse [4 points]; 30% reuse [5 points]; 40% reuse [6 points].	<input type="checkbox"/>	<input checked="" type="checkbox"/>	<input type="checkbox"/>	<input type="checkbox"/>	<input type="checkbox"/>	0
4.6	Omit	Access to Potable Water during Emergencies	Not allowed if the project receives funding from Minnesota Housing.	<input type="checkbox"/>	<input type="checkbox"/>	<input checked="" type="checkbox"/>	<input type="checkbox"/>	<input type="checkbox"/>	6
Subtotal Category 4 Selected Optional Points									6

Key to Column Headers:

C# = Criteria Number, M/O = Mandatory Criteria or Optional Criteria Points, N/A = Not Applicable, WR = Waiver Request, OP = Selected Optional Points

C#	M/O	Criteria Title	Criteria Description	How Will Criteria Be Implemented? And, where in the plans, specifications, or other place will compliance be documented?	Intent to Comply				
					Yes	No	N/A	WR	OP

5. Energy Efficiency Category

5.1a	M	Building Performance Standard: NC Energy Star for Homes (Mandatory for NC, Single Family and Low-rise MF)	Certify each dwelling unit in the project through the ENERGY STAR New Homes or Multifamily New Construction (MFNC) program.	We will certify each dwelling to EnergyStar New Homes.	<input checked="" type="checkbox"/>	<input type="checkbox"/>	<input type="checkbox"/>	<input type="checkbox"/>	<input type="checkbox"/>
5.1b	M	Building Performance Standard: NC ASHRAE 90.1/Energy Star MFHR (Mandatory for NC 4 & 5 + NC 6 Story or more)	Follow one of Three Compliance Pathways: 1) Buildings 4 Stories or more WITH Heated Garage 2) Buildings 4 Stories or more WITHOUT Heated Garage 3) Buildings with up to 5 Stories (dwelling units with own heating, cooling, and hot water heating) WITH or WITHOUT a Heated Garage Or, follow the ENERGY STAR Multifamily New Construction (MFNC) program.	We will follow the prescriptive design for buildings <u>without heated garages.</u>	<input checked="" type="checkbox"/>	<input type="checkbox"/>	<input type="checkbox"/>	<input type="checkbox"/>	<input type="checkbox"/>
5.1c	M	Building Performance Standard (Mandatory for Sub/Gut and Mod Rehab: Single Family and Low-rise Multifamily)	For Sub/Gut Rehab, each dwelling unit, achieve a HERS Index score of 85 or less. For Mod Rehab, Performance Pathway HERS 85 or 100; OR, MN Overlay Prescriptive Pathway.		<input type="checkbox"/>	<input type="checkbox"/>	<input checked="" type="checkbox"/>	<input type="checkbox"/>	<input type="checkbox"/>
5.1d	M	Building Performance Standard: (Mandatory for Sub/Gut and Mod Rehab: Mid-rise and High-rise Multifamily)	For Sub/Gut Rehab, each dwelling unit, follow a Performance Pathway and demonstrate equivalent performance to ASHRAE 90.1-2010. For Mod Rehab, each dwelling unit, follow Performance Pathway; OR, Prescriptive Pathway.		<input type="checkbox"/>	<input type="checkbox"/>	<input checked="" type="checkbox"/>	<input type="checkbox"/>	<input type="checkbox"/>
5.2a	5 - 12	Additional Reductions in Energy Use	Design and construct a building that is projected to be at least 5% more efficient than what is required of the project by Criteria 5.1a-d. (Projects may receive points in Criteria 5.2a or 5.2b, but not both)		<input type="checkbox"/>	<input checked="" type="checkbox"/>	<input type="checkbox"/>	<input type="checkbox"/>	<input type="checkbox"/>
5.2b	12	Advanced Certification: Net Zero	Certify the project in a program that requires advanced levels of building envelope performance such as PHILUS, Living Building Challenge and/or DOE Zero Energy Ready Home. (Projects receiving points in Criterion 5.2b may not receive points per Criterion 5.2a)		<input type="checkbox"/>	<input checked="" type="checkbox"/>	<input type="checkbox"/>	<input type="checkbox"/>	<input type="checkbox"/>

Key to Column Headers:

C# = Criteria Number, M/O = Mandatory/Criterial or Optional Criteria Points,
N/A = Not Applicable, WR = Waiver Request, OP = Selected Optional Points

C#	M/O	Criteria Title	Criteria Description	How Will Criteria Be Implemented? And, where in the plans, specifications, or other place will compliance be documented?	Intent to Comply				
					Yes	No	N/A	WR	OP
5.3	M	Sizing of Heating and Cooling Equipment (Mandatory for NC and all Rehab if scope of work includes HVAC work)	Size and select heating and cooling equipment in accordance with the Air Conditioning Contractors of America (ACCA) Manuals J and S or ASHRAE handbooks.	HVAC equipment will be sized properly and balanced at the completion of construction.	<input checked="" type="checkbox"/>	<input type="checkbox"/>	<input type="checkbox"/>	<input type="checkbox"/>	<input type="checkbox"/>
5.4	M	ENERGY STAR Appliances (Mandatory for NC and for all Rehab if new appliances are included in the scope of work)	If providing appliances, install ENERGY STAR clothes washers, dishwashers and refrigerators. If appliances will not be installed or replaced at this time, specify that, at the time of installation or replacement, ENERGY STAR models must be used.	EnergyStar appliances will be utilized.	<input checked="" type="checkbox"/>	<input type="checkbox"/>	<input type="checkbox"/>	<input type="checkbox"/>	<input type="checkbox"/>
5.5	M	Lighting (Mandatory for NC and for any "new" fixtures at all Rehab)	Follow the guidance for high-efficacy lighting controls and other characteristics for any new permanently installed lighting fixtures in project dwelling units, common spaces and exterior.	High efficiency lighting controls will be incorporated into the plans and specs.	<input checked="" type="checkbox"/>	<input type="checkbox"/>	<input type="checkbox"/>	<input type="checkbox"/>	<input type="checkbox"/>
5.6	M - 6	Electricity Meter (Mandatory for NC and Sub/Gut Rehab) (Optional 6 points for Mod Rehab)	Install individual or submetered electric meters for all dwelling units.	Individual meters will be installed. Residents will pay their own electric bills.	<input checked="" type="checkbox"/>	<input type="checkbox"/>	<input type="checkbox"/>	<input type="checkbox"/>	<input type="checkbox"/>
5.7a	4	Photovoltaic/Solar Hot Water Ready	Orient, design, engineer, wire and/or plumb the development to accommodate installation of photovoltaic (PV) or solar hot water system in the future.		<input type="checkbox"/>	<input checked="" type="checkbox"/>	<input type="checkbox"/>	<input type="checkbox"/>	<input type="checkbox"/>
5.7b	10 max	Renewable Energy	Install photovoltaic (PV) panels or other electric-generating renewable energy source to provide a specified percentage of the project's estimated total energy demand or water heating energy demand. (Projects may earn points through Criterion 5.7b or 5.8b, but not both.)		<input type="checkbox"/>	<input checked="" type="checkbox"/>	<input type="checkbox"/>	<input type="checkbox"/>	<input type="checkbox"/>

Key to Column Headers:
 C# = Criteria Number, M/O = Mandatory Criterion or Optional Criteria Points,
 N/A = Not Applicable, WR = Waiver Request, OP = Selected Optional Points

C#	M/O	Criteria Title	Criteria Description	How Will Criteria Be Implemented? And, where in the plans, specifications, or other place will compliance be documented?	Intent to Comply				
					Yes	No	N/A	WR	OP
5.8a	8	Resilient Energy Systems: Floodproofing	Conduct floodproofing, including perimeter floodproofing (barriers/shields), of lower floors. Design and install building systems as specified by the full criterion so that the operation of those systems will not be grossly affected in case of a flood.		<input type="checkbox"/>	<input checked="" type="checkbox"/>	<input type="checkbox"/>	<input type="checkbox"/>	
5.8b	8	Resilient Energy Systems: Islandable Power	Provide emergency power through an islandable photovoltaic (PV) system or an efficient and permanent generator that will offer at least limited electricity for critical circuits during power outages per one of the three options listed. (Projects may earn points through Criterion 5.7b or 5.8b, but not both.)		<input type="checkbox"/>	<input checked="" type="checkbox"/>	<input type="checkbox"/>	<input type="checkbox"/>	
Subtotal Category 5 Selected Optional Points									0

Key to Column Headers:
 C# = Criteria Number, M/O = Mandatory Criterion or Optional Criteria Points,
 N/A = Not Applicable, WR = Waiver Request, OP = Selected Optional Points

C#	M/O	Criteria Title	Criteria Description	How Will Criteria Be Implemented? And, where in the plans, specifications, or other place will compliance be documented?	Intent to Comply				
					Yes	No	N/A	WR	OP

6. Materials Category

6.1	M	Low/No VOC Paints, Coatings and Primers (Mandatory for NC and for all Rehab if included in scope of work)	All interior paints and primers must have VOC levels, in grams per liter, less than or equal to the thresholds established by South Coast Air Quality Management District (SCAQMD) Rule 1113.	The project plans and specs will assure low/no VOC paints and coatings.	<input checked="" type="checkbox"/>	<input type="checkbox"/>	<input type="checkbox"/>	<input type="checkbox"/>	<input type="checkbox"/>
6.2	M	Low/No VOC Adhesives and Sealants (Mandatory for NC and for all Rehab if included in scope of work)	All adhesives and sealants (including caulks) must have VOC levels, in grams per liter, less than or equal to the thresholds established by the South Coast Air Quality Management District Rule 1168.	The project plans and specs will assure low/no VOC adhesives and sealants.	<input checked="" type="checkbox"/>	<input type="checkbox"/>	<input type="checkbox"/>	<input type="checkbox"/>	<input type="checkbox"/>
6.3	3 max	Recycled Content Material	Incorporate building materials that are composed of at least 25% post-consumer recycled content or at least 50% post-industrial recycled content. [1 point] Building materials that make up at least 75% of their project component each receive 1 point.		<input type="checkbox"/>	<input checked="" type="checkbox"/>	<input type="checkbox"/>	<input type="checkbox"/>	<input type="checkbox"/>
6.4	4 max	Regional Material	Use products that were extracted, processed and manufactured within 500 miles of the project for a minimum of 50%, based on cost of the building materials' value. Select any or all of these options (each material can qualify for 1 point): <ul style="list-style-type: none"> • Framing materials • Exterior materials (e.g., siding, masonry, roofing) • Flooring materials • Concrete/cement and aggregate material • Drywall/interior sheathing materials 		<input type="checkbox"/>	<input checked="" type="checkbox"/>	<input type="checkbox"/>	<input type="checkbox"/>	<input type="checkbox"/>
6.5	1	Certified, Salvaged and Engineered Wood Products	For at least 25% of all structural wood products, by cost or value, commit to using either FSC-certified, salvaged products or engineered framing materials without urea formaldehyde.		<input type="checkbox"/>	<input checked="" type="checkbox"/>	<input type="checkbox"/>	<input type="checkbox"/>	<input type="checkbox"/>

Key to Column Headers:

C# = Criteria Number, M/O = Mandatory Criterion or Optional Criteria Points, N/A = Not Applicable, WR = Waiver Request, OP = Selected Optional Points

C#	M/O	Criteria Title	Criteria Description	How Will Criteria Be Implemented? And, where in the plans, specifications, or other place will compliance be documented?	Intent to Comply				
					Yes	No	N/A	WR	OP
6.6	M	Composite Wood Products that Emit Low/No Formaldehyde (Mandatory for NC and for all Rehab if in scope of work)	All composite wood products must be certified as compliant with California 93120 Phase 2 OR, if using a composite wood product that does not comply with California 93120 Phase 2, all exposed edges and sides must be sealed with low-VOC sealants, per Criterion 6.2.	The project plans and specs will require the adherence to this criteria.	<input checked="" type="checkbox"/>	<input type="checkbox"/>	<input type="checkbox"/>	<input type="checkbox"/>	<input type="checkbox"/>
6.7a	M	Environmentally Preferable Flooring (Mandatory for NC and for all Rehab if new flooring in the scope of work)	Do not install carpets in building entryways, laundry rooms, bathrooms, kitchens/kitchenettes, utility rooms or any rooms built on foundation slabs (aka Ground-connected Concrete Slabs). Exceptions: 1) Properly installed vapor barrier, 2) Functioning drain tile, 3) Capillary Break and vapor barrier, or 4) Poly-film test confirmation.	the project plans and specs will require this criteria will be followed.	<input checked="" type="checkbox"/>	<input type="checkbox"/>	<input type="checkbox"/>	<input type="checkbox"/>	<input type="checkbox"/>
6.7b	6	Environmentally Preferable Flooring Throughout	Use non-vinyl, non-carpet floor coverings throughout each building in the project.		<input type="checkbox"/>	<input checked="" type="checkbox"/>	<input type="checkbox"/>	<input type="checkbox"/>	<input type="checkbox"/>
6.8	M	Mold Prevention: Surfaces (Mandatory for all)	Use materials that have durable, cleanable surfaces throughout bathrooms, kitchens and laundry rooms. Materials installed in these rooms should not be prone to deterioration due to moisture intrusion or encourage the growth of mold.	The project plans and specs will assure no mold prone materials are used in bathrooms, kitchens and laundry rooms.	<input checked="" type="checkbox"/>	<input type="checkbox"/>	<input type="checkbox"/>	<input type="checkbox"/>	<input type="checkbox"/>
6.9	M	Mold Prevention: Tub and Shower Enclosures (Mandatory for NC and all Rehab if applicable shower or bathroom work is in the scope of work)	Use moisture-resistant backing materials such as cement board, fiber cement board or equivalent per ASTM #D3273 behind tub/shower enclosures. Projects using a one-piece fiberglass tub/shower enclosure are exempt from this requirement.	The plans and specs will specify moisture-resistance backing at tubs and showers.	<input checked="" type="checkbox"/>	<input type="checkbox"/>	<input type="checkbox"/>	<input type="checkbox"/>	<input type="checkbox"/>

Key to Column Headers:

C# = Criteria Number, M/O = Mandatory Criterion or Optional Criteria Points,
N/A = Not Applicable, WR = Waiver Request, OP = Selected Optional Points

C#	M/O	Criteria Title	Criteria Description	How Will Criteria Be Implemented? And, where in the plans, specifications, or other place will compliance be documented?	Intent to Comply				
					Yes	No	N/A	WR	OP
6.10	12 max	Asthma-free Materials	Do not install products that contain ingredients that are known to cause or trigger asthma. Key products to avoid are: <ul style="list-style-type: none"> • Insulation: Do not use spray polyurethane foam (SPF) or formaldehyde-containing fiberglass batts. [4 points] • Flooring: Do not use flexible vinyl (PVC) roll or sheet flooring or carpet-backed with vinyl with phthalates. Do not use fluid applied finish floors. [4 points] • Wall coverings: Do not use wallpaper made from vinyl (PVC) with phthalates or site-applied high-performance coatings that are epoxy or polyurethane based. [4 points] • Composite wood: Use only ULEF products for cabinetry, subflooring and other interior composite wood uses. [4 points] 		<input type="checkbox"/>	<input checked="" type="checkbox"/>	<input type="checkbox"/>	<input type="checkbox"/>	<input type="checkbox"/>
6.11	5	Reduced Heat-Island Effect: Roofing	Use an ENERGY STAR-certified roofing product for 100% of the roof area OR install a "green" (vegetated) roof for at least 50% of the roof area and ENERGY STAR-certified roofing product for the remainder of the roof area.		<input type="checkbox"/>	<input checked="" type="checkbox"/>	<input type="checkbox"/>	<input type="checkbox"/>	<input type="checkbox"/>
6.12	M - 6	Construction Waste Management (Mandatory minimum requirements for all projects. Optional points are available for projects that go beyond mandatory.)	Commit to following a waste management plan that reduces non-hazardous construction and demolition waste through recycling, salvaging or diversion strategies through one of the three options. Achieve optional points by going above and beyond the requirement [6 points max].	The development will commit to Option 1, item a, diverting at least 50% of materials to recycling.	<input checked="" type="checkbox"/>	<input type="checkbox"/>	<input type="checkbox"/>	<input type="checkbox"/>	<input type="checkbox"/>

Key to Column Headers:

C# = Criteria Number, M/O = Mandatory Criteria or Optional Criteria Points, N/A = Not Applicable, WR = Waiver Request, OP = Selected Optional Points

C#	M/O	Criteria Title	Criteria Description	How Will Criteria Be Implemented? And, where in the plans, specifications, or other place will compliance be documented?	Intent to Comply					
					Yes	No	N/A	WR	OP	
6.13	3	Recycling Storage for Multifamily Project	Provide separate bins for the collection of trash and recycling for each dwelling unit and all shared community rooms (if applicable). Additionally, in multifamily buildings, provide at least one easily accessible, permanent and dedicated indoor area for the collection and storage of materials for recycling. In single-family homes, points will be accrued only if curb-side recycling pickup is available. Collected materials should include, at a minimum, paper, cardboard, glass, metals and plastics.	The development will include a permanent and dedicated indoor area for the collection of recycling.	<input checked="" type="checkbox"/>	<input type="checkbox"/>	<input type="checkbox"/>	<input type="checkbox"/>		3
Subtotal Category 6 Selected Optional Points										3

Key to Column Headers:

C# = Criteria Number, M/O = Mandatory Criteria or Optional Criteria Points, N/A = Not Applicable, WR = Waiver Request, OP = Selected Optional Points

C#	M/O	Criteria Title	Criteria Description	How Will Criteria Be Implemented? And, where in the plans, specifications, or other place will compliance be documented?	Intent to Comply				
					Yes	No	N/A	WR	OP

7. Healthy Living Environment Category

7.1	M	Ventilation (Mandatory for all, including Mod Rehab)	<p>For each dwelling unit, in full accordance with ASHRAE 62.2-2010, install a local mechanical exhaust system in each bathroom, a local mechanical exhaust system in each kitchen, or a whole-house mechanical ventilation system.</p> <p>For each multifamily building of four stories and more, in full accordance with ASHRAE 62.1-2010, install a mechanical ventilation system for all hallways and common spaces</p> <p>For all project types, in addition to the above requirements:</p> <ul style="list-style-type: none"> All systems and associated ductwork must be installed per manufacturer's recommendations. All individual bathroom fans must be ENERGY STAR labeled, wired to turn on with the light switch, and equipped with a humidistat sensor, timer or other control (e.g., occupancy sensor, delay off switch, ventilation controller). If using central ventilation systems with rooftop fans, each rooftop fan must be direct-drive and variable-speed with speed controller mounted near the fan. Fans with design CFM 300-2000 must also have an ECM motor. <p>Exception: If approved by Minnesota Housing, existing, operable, functioning bath fans and kitchen fans may be permitted to remain for compliance with this criteria.</p>	The project will meet the requirements of ASHRAE 62.1-2010.	<input checked="" type="checkbox"/>	<input type="checkbox"/>	<input type="checkbox"/>	<input type="checkbox"/>	<input type="checkbox"/>
7.2	M	Clothes Dryer Exhaust (Mandatory for all)	<p>Clothes dryers must be exhausted directly to the outdoors using rigid-type ductwork (except for condensing dryers, which must be plumbed to a drain).</p>	Clothes dryers will exhaust to the exterior.	<input checked="" type="checkbox"/>	<input type="checkbox"/>	<input type="checkbox"/>	<input type="checkbox"/>	<input type="checkbox"/>

Key to Column Headers:

C# = Criteria Number, M/O = Mandatory Criteria or Optional Criteria Points,
N/A = Not Applicable, WR = Waiver Request, OP = Selected Optional Points

C#	M/O	Criteria Title	Criteria Description	How Will Criteria Be Implemented? And, where in the plans, specifications, or other place will compliance be documented?	Intent to Comply				
					Yes	No	N/A	WR	OP
7.3	M	Combustion Safety (Mandatory for all)	At NC, only provide in-unit space and water heating with power-vented or closed (sealed) combustion equipment. At Rehab, replace existing in-unit space and water heating natural draft combustion equipment with new power-vented or closed (sealed) combustion equipment. If existing natural draft combustion equipment is planned to remain, a combustion action plan with post-combustion testing must be provided.	There will be no in-unit space or water heating equipment.	<input checked="" type="checkbox"/>	<input type="checkbox"/>	<input type="checkbox"/>	<input type="checkbox"/>	<input type="checkbox"/>
7.4	9 or 11	Elimination of Combustion within the Conditioned Space (Optional points for NC and Rehab)	No combustion equipment may be used for cooking (including, but not limited to, ranges, cooktops, stoves, ovens) as part of the building project for NC or existing combustion equipment replaced with electric equipment [9 points]. OR no combustion equipment may be used as part of the building project [11 points].	There will be no combustion equipment used for cooking.	<input checked="" type="checkbox"/>	<input type="checkbox"/>	<input type="checkbox"/>	<input type="checkbox"/>	9
7.5	M	Vapor Retarder Strategies (Mandatory for NC and for all Rehab projects with foundation work)	Install vapor barriers that meet specified criteria appropriate for the foundation type.	All vapor barriers will meet specified criteria.	<input checked="" type="checkbox"/>	<input type="checkbox"/>	<input type="checkbox"/>	<input type="checkbox"/>	
7.6	M	Water Drainage (Mandatory for NC and all Rehab projects replacing assemblies called out in criterion only)	Provide drainage of water away from walls, windows and roofs by implementing the list of techniques.	Grading and drainage plans will assure drainage moves appropriately away from the building.	<input checked="" type="checkbox"/>	<input type="checkbox"/>	<input type="checkbox"/>	<input type="checkbox"/>	
7.7	M	Mold Prevention: Water Heaters (Mandatory for all)	Provide adequate drainage for water heaters that includes drains or catch pans with drains piped to the exterior of the dwelling.	Design will include central water heater system. Adequate drainage will be incorporated.	<input checked="" type="checkbox"/>	<input type="checkbox"/>	<input type="checkbox"/>	<input type="checkbox"/>	
7.8	M	Radon Mitigation (Mandatory for all)	Refer to Minnesota Housing Environmental Standards for Radon requirements.		<input checked="" type="checkbox"/>	<input type="checkbox"/>	<input type="checkbox"/>	<input type="checkbox"/>	

Key to Column Headers:

C# = Criteria Number, M/O = Mandatory Criterion or Optional Criteria Points,
N/A = Not Applicable, WR = Waiver Request, OP = Selected Optional Points

C#	M/O	Criteria Title	Criteria Description	How Will Criteria Be Implemented? And, where in the plans, specifications, or other place will compliance be documented?	Intent to Comply				
					Yes	No	N/A	WR	OP
7.9	M	Garage Isolation (Mandatory for all)	<ul style="list-style-type: none"> • Provide a continuous air barrier between the conditioned space and any garage space to prevent the migration of any contaminants into the living space. • Visually inspect common walls and ceilings between attached garages and living spaces to ensure that they are air-sealed before insulation is installed. • Do not install ductwork or air handling equipment in a garage. • Fix all connecting doors between conditioned space and garage with gaskets, or otherwise make substantially airtight with weather stripping. • Install one hard-wired carbon monoxide (CO) alarm with battery backup function for each sleeping zone of the project, placed per National Fire Protection Association (NFPA) 720. 	Garage isolation measures will be incorporated into the plans and specs.	<input checked="" type="checkbox"/>	<input type="checkbox"/>	<input type="checkbox"/>	<input type="checkbox"/>	<input type="checkbox"/>
7.10	M	Integrated Pest Management (Mandatory for all)	Seal all wall, floor and joint penetrations with low-VOC caulking or other appropriate nontoxic sealing methods to prevent pest entry.	Integrated pest management will be incorporated into the design.	<input checked="" type="checkbox"/>	<input type="checkbox"/>	<input type="checkbox"/>	<input type="checkbox"/>	<input type="checkbox"/>
7.11a	9	Beyond ADA: Universal Design (NC)	Design a minimum of 15% of the dwelling units (no fewer than one) in accordance with ICC/ANSI A117.1, Type A, Fully Accessible guidelines. Design the remainder of the ground-floor units and elevator-reachable units in accordance with ICC/ANSI A117.1, Type B.		<input type="checkbox"/>	<input checked="" type="checkbox"/>	<input type="checkbox"/>	<input type="checkbox"/>	<input type="checkbox"/>
7.11b	7 or 9	Beyond ADA: Universal Design (Sub/Gut and Mod Rehab only)	Design a minimum of 10% of the dwelling units (no fewer than one) in accordance with ICC/ANSI A117.1, Type A, Fully Accessible guidelines. [7 points] For an additional 2 points: Design the remainder of the ground-floor units and elevator-reachable units with accessible unit entrances designed to accommodate people who use a wheelchair.		<input type="checkbox"/>	<input checked="" type="checkbox"/>	<input type="checkbox"/>	<input type="checkbox"/>	<input type="checkbox"/>

Key to Column Headers:

C# = Criteria Number, M/O = Mandatory Criteria or Optional Criteria Points,
N/A = Not Applicable, WR = Waiver Request, OP = Selected Optional Points

C#	M/O	Criteria Title	Criteria Description	How Will Criteria Be Implemented? And, where in the plans, specifications, or other place will compliance be documented?	Intent to Comply					
					Yes	No	N/A	WR	OP	
7.12	M	Active Design: Promoting Physical Activity within the Building (Mandatory for all)	Situate at least one building stairway per the criterion to encourage use OR emphasize at least one strategy inside the building designed to increase frequency and duration of physical activity per the criterion.	A stairway leading to each floor will incorporate the guidelines of Option 1.	<input checked="" type="checkbox"/>	<input type="checkbox"/>	<input type="checkbox"/>	<input type="checkbox"/>	<input type="checkbox"/>	
7.13	10	Active Design: Staircases and Building Circulation	A staircase must be accessible and visible from the main lobby as well as visible within a 25-foot walking distance from any edge of the lobby. Ensure that no turns or obstacles prevent visibility of or accessibility to the qualifying staircase from the lobby, and that the staircase is encountered before or at the same time as the elevators. From the corridor, accessible staircases should be made visible by: Providing transparent glazing of at least 10 square feet (1 square meter) at all stair doors or at a side light OR providing magnetic door holds on all doors leading to the stairs OR removing door enclosures/vestibules.		<input type="checkbox"/>	<input checked="" type="checkbox"/>	<input type="checkbox"/>	<input type="checkbox"/>	<input type="checkbox"/>	
7.14	9	Interior and Outdoor Activity Spaces for Children and Adults (Applicable to NC and to all Rehab if existing, older, worn equipment replaced)	Provide an on-site dedicated recreation space with exercise or play opportunities for adults and/or children that is open and accessible to all residents; refer to criterion for specifics.	Both a playground area and an interior fitness room will be designed into the project.	<input checked="" type="checkbox"/>	<input type="checkbox"/>	<input type="checkbox"/>	<input type="checkbox"/>	<input type="checkbox"/>	9
7.15	M	Reduce Lead Hazards (Mandatory for all Rehab)	Refer to Minnesota Housing Environmental Standards for Lead-based Paint Hazard requirements.		<input type="checkbox"/>	<input type="checkbox"/>	<input checked="" type="checkbox"/>	<input type="checkbox"/>	<input type="checkbox"/>	
7.16	10	Smoke-free Building	Implement and enforce a no-smoking policy in all common and individual living areas and within a 25-foot perimeter around the exterior of all residential projects.	Will incorporate existing smoke-free lease and policies for this development.	<input checked="" type="checkbox"/>	<input type="checkbox"/>	<input type="checkbox"/>	<input type="checkbox"/>	<input type="checkbox"/>	10

Subtotal Category 7 Selected Optional Points 28

Key to Column Headers:
 C# = Criteria Number, M/O = Mandatory Criterion or Optional Criteria Points,
 N/A = Not Applicable, WR = Waiver Request, OP = Selected Optional Points

C#	M/O	Criteria Title	Criteria Description	How Will Criteria Be Implemented? And, where in the plans, specifications, or other place will compliance be documented?	Intent to Comply				
					Yes	No	N/A	WR	OP

8. Operations, Maintenance and Resident Engagement Category

8.1	M	Building Maintenance Manual (Mandatory for all multifamily projects)	Develop a manual with thorough building operations and maintenance guidance and a complementary plan. The manual and plan should be developed over the course of the project design, development and construction stages, and should include sections/chapters addressing the list of topics.		<input checked="" type="checkbox"/>	<input type="checkbox"/>	<input type="checkbox"/>	<input type="checkbox"/>	<input type="checkbox"/>
8.2	M	Emergency Management Manual (Mandatory for all multifamily projects)	Provide a manual on emergency operations targeted toward operations and maintenance staff and other building-level personnel. The manual should address responses to various types of emergencies, leading with those that have the greatest probability of negatively affecting the project. The manual should provide guidance as to how to sustain the delivery of adequate housing throughout an emergency and cover a range of topics, including but not limited to: <ul style="list-style-type: none"> • communication plans for staff and residents • useful contact information for public utility and other service providers • Infrastructure and building "shutdown" procedures. 		<input checked="" type="checkbox"/>	<input type="checkbox"/>	<input type="checkbox"/>	<input type="checkbox"/>	<input type="checkbox"/>
8.3	M	Resident Manual (Mandatory for all)	Provide a guide for homeowners and renters that explains the intent, benefits, use and maintenance of their home's green features and practices. The Resident Manual should encourage green and healthy activities per the list of topics.		<input checked="" type="checkbox"/>	<input type="checkbox"/>	<input type="checkbox"/>	<input type="checkbox"/>	<input type="checkbox"/>

Key to Column Headers:

C# = Criteria Number, M/O = Mandatory Criteria or Optional Criteria Points,
N/A = Not Applicable, WR = Waiver Request, OP = Selected Optional Points

C#	M/O	Criteria Title	Criteria Description	How Will Criteria Be Implemented? And, where in the plans, specifications, or other place will compliance be documented?	Intent to Comply				
					Yes	No	N/A	WR	OP
8.4	M	Resident and Property Staff Orientation (Mandatory for all)	Provide a comprehensive walk-through and orientation for all residents, property manager(s) and buildings operations staff. Use the appropriate manuals (refer to Criteria 8.1, 8.2, 8.3) as the base of the curriculum, and review the project's green features, operations and maintenance procedures, and emergency protocols.	<input checked="" type="checkbox"/>	<input type="checkbox"/>	<input type="checkbox"/>	<input type="checkbox"/>	<input type="checkbox"/>	
8.5	O	Project Data Collection and Monitoring System: 100% Owner Paid Utility Accounts, 15% Tenant Paid Utility Accounts (Optional, no points)	For rental properties: Collect and monitor project energy and water performance data for 100% of owner-paid utilities and 15% of tenant-paid utilities for at least 5 years. This data must be maintained in a manner that allows staff to easily access and monitor it, enabling them to make informed operations and capital planning decisions. Also allow Enterprise access to this data. For owner-occupied units: Collect and monitor energy and water performance data in a manner that allows for easy access and review and provides the ability to influence home operations. Also allow Enterprise access to this data.	<input type="checkbox"/>	<input checked="" type="checkbox"/>	<input type="checkbox"/>	<input type="checkbox"/>	<input type="checkbox"/>	
8.6	7 or 11	Project Data Collection and Monitoring System: >15% Tenant Paid Utility Accounts (Must include Criteria 8.5 requirements as well to claim 8.6 criteria points)	Collect and monitor project energy and water performance data for at least 5 years. This data must be maintained in a manner that allows staff to easily access and monitor it, enabling them to make informed operations and capital planning decisions. Also allow Enterprise access to this data. 16–60% of units [7 points]; 60–100% of units [11 points].	<input type="checkbox"/>	<input checked="" type="checkbox"/>	<input type="checkbox"/>	<input type="checkbox"/>	<input type="checkbox"/>	
Subtotal Category 8 Selected Optional Points					0				
Total Selected Optional Points					60				

Key to Column Headers:
 C# = Criteria Number, M/O = Mandatory Criteria or Optional Criteria Points,
 N/A = Not Applicable, WR = Waiver Request, OP = Selected Optional Points

C#	M/O	Criteria Title	Criteria Description	How Will Criteria Be Implemented? And, where in the plans, specifications, or other place will compliance be documented?	Intent to Comply				
					Yes	No	N/A	WR	OP

Intent to Comply Certification - Initial Application Phase

I/we hereby certify to Minnesota Housing that all applicable Mandatory and selected Optional Point Criteria of the 2015 Enterprise Green Communities Criteria as amended by the current/applicable version of the MN Overlay to the 2015 EGCC (unless exempt by a Minnesota Housing approved waiver) are incorporated into the approved contract documents for the above mentioned development.

Borrower/Developer/Owner

Duffy Development Company, Inc.

Firm/Organization/Company

Signature

Typed/Printed Name of Person Signing

Date

Jeffrey J. Von Feldt

Architect of Record/Borrower's Architect

Cole Group Architects, LLC

Firm/Organization/Company

Signature

Typed/Printed Name of Person Signing

Date



Norm Cole

5-21-19

Contract Document Compliance Certification - Loan Commitment/Closing (MF Only) Phase

I/we hereby certify to Minnesota Housing that all applicable Mandatory and selected Optional Point Criteria of the 2015 Enterprise Green Communities Criteria as amended by the current/applicable version of the MN Overlay to the 2015 EGCC (unless exempt by a Minnesota Housing approved waiver) are incorporated into the approved contract documents and construction contract for the above mentioned development.

Borrower/Developer/Owner

Insert Firm/Organization/Company

Signature

Typed/Printed Name of Person Signing

Date

Architect of Record/Borrower's Architect

Insert Firm/Organization/Company

Signature

Typed/Printed Name of Person Signing

Date

General Contractor

Insert Firm/Organization/Company

Signature

Typed/Printed Name of Person Signing

Date

Key to Column Headers:

C# = Criteria Number, M/O = Mandatory Criterion or Optional Criteria Points, N/A = Not Applicable, WR = Waiver Request, OP = Selected Optional Points

C#	M/O	Criteria Title	Criteria Description	How Will Criteria Be Implemented? And, where in the plans, specifications, or other place will compliance be documented?	Intent to Comply				
					Yes	No	N/A	WR	OP

Compliance Certification - End of Construction/Construction Close-Out Phase

I/we hereby certify to Minnesota Housing that all applicable Mandatory and selected Optional Point Criteria of the 2015 Enterprise Green Communities Criteria as amended by the current/applicable version of the MN Overlay to the 2015 EGCC (unless exempt by a Minnesota Housing approved waiver) are incorporated into the approved contract documents and construction contract for the above mentioned development.

Borrower/Developer/Owner				
	Insert Firm/Organization/Company	Signature	Typed/Printed Name of Person Signing	Date
Architect of Record/Borrower's Architect				
	Insert Firm/Organization/Company	Signature	Typed/Printed Name of Person Signing	Date
General Contractor				
	Insert Firm/Organization/Company	Signature	Typed/Printed Name of Person Signing	Date

Key to Column Headers:

C# = Criteria Number, M/O = Mandatory Criterion or Optional Criteria Points,
N/A = Not Applicable, WR = Waiver Request, OP = Selected Optional Points

Project Information

Project Name and Location Bottineau Ridge Phase III, Maple Grove
D# (if known) D8225

Universal Design Definition and Scoring

A Universal Design (UD) unit is a unit that includes all minimum essential UD features listed below, along with the required and optional UD features by project type. Minnesota Housing determined the project should receive three (3) Selection Priority Points in the Low Income Housing Tax Credit (HTC) scoring for funding eligibility determination.

Building Type

Check the type of building that applies:

- An elevator equipped building with 100 percent of assisted units meeting the definition of UD units.
 A non-elevator equipped building with at least 10 percent of assisted units meeting the definition of UD units.

Indicate % of UD units: _____

Indicate total number of dwelling units: _____

Project Type and Universal Design (UD) Optional Features

Check the project type that applies:

- New construction or adaptive re-use project that includes at least eight (8) optional UD features
 Rehabilitation project that includes at least four (4) optional UD features

Type A accessible units (as referenced in Minnesota Housing's Rental Housing Design and Construction Standards, available at the [Building Standards](#) webpage) are considered to meet the definition of a UD unit for scoring purposes.

Scattered site projects may use one Universal Design Worksheet, and calculate the overall percentage of UD units required based on the total dwelling units, provided all properties are the same building type (elevator equipped or non-elevator equipped).

Minimum Essential Universal Design Features Required

- At least one bedroom or space that can be converted to a bedroom (without changing door locations for new construction or adaptive re-use) must be on an accessible level and connected to an accessible route.
- At least 42" minimum hallways must be included within a unit for new construction or adaptive reuse.
- At least one, three quarter bathroom on an accessible level, with a minimum five foot open radius for new construction or an adaptive reuse unit, and clear floor space of 30" x 48" must be included for rehabilitation projects. Accessible "T" turn clearance may be accepted in lieu of the five foot open radius.
- All doors and plumbing fixtures must include lever handles.
- Wall blocking must be provided in all tub and shower areas for new construction or adaptive re-use, and for rehabilitation if showers are being replaced.
- Door thresholds flush with the floor with maximum threshold height of ½" beveled or ¼" square edged.
- Kitchen and laundry appliances must have parallel approach, clear floor space with all controls within a maximum height of 48". Oven controls must have a lockout feature. Stackable laundry units with a maximum reach range of 54" will meet this requirement.
- If microwave/exhaust hood combination appliances are provided in 95 percent of UD units, then the remaining 5 percent of UD units must provide a countertop or other accessible microwave or have one in stock and on-site and available upon request.
- Kitchen sink area must be 30" wide minimum, with a cabinet panel concealing piping or a removable base cabinet.
- All common spaces and amenities provided in the development are located on an accessible route.
- For new construction or adaptive re-use projects, deck and patio spaces must have a step-less transition meeting door threshold requirements above, with decking gaps no greater than ¼". A step-less transition and door threshold meeting requirements as promulgated by Minnesota Accessibility Code for Type A units is also permitted
- UD features are incorporated in an aesthetically pleasing, marketable, non-institutional manner.

All minimum essential UD features are included in the UD units

No

Yes

Optional Universal Design Features [Eight (8) minimum new construction/ adaptive re-use; for (4) minimum rehab.]

Item	Included	
High contrast finish selections that include floor to wall transitions, top treads of stairs, counters and adjacent flooring and walls	<input type="checkbox"/> No	<input checked="" type="checkbox"/> Yes
Single lever, hands free, or touch type faucets are provided throughout the UD dwelling unit	<input type="checkbox"/> No	<input checked="" type="checkbox"/> Yes
At least 50% of kitchen storage space is within reach ranges from pull-out shelves, full extension glide drawers, or is within a roll-in pantry	<input type="checkbox"/> No	<input type="checkbox"/> Yes
A variety of work surface heights and one five foot open radius in the kitchen	<input type="checkbox"/> No	<input type="checkbox"/> Yes
Roll under vanity or sink in 25% of UD qualifying units, rounded up to the nearest whole number	<input type="checkbox"/> No	<input type="checkbox"/> Yes
Cabinet hardware with “D” type pull handles or operation for people with limited dexterity	<input type="checkbox"/> No	<input checked="" type="checkbox"/> Yes
Zero threshold shower or transfer space at tub is provided at a minimum of half the qualifying UD units, rounded up to the nearest whole number	<input type="checkbox"/> No	<input checked="" type="checkbox"/> Yes
Slip resistant flooring in kitchens and baths in the UD dwelling units *	<input type="checkbox"/> No	<input checked="" type="checkbox"/> Yes
Toilets provided with seats that are 17” – 19” from the floor	<input type="checkbox"/> No	<input checked="" type="checkbox"/> Yes
Windows are provided with a maximum sill height of 36”, parallel approach, clear floor space and locks/operating mechanism within 48” and easily operable with one hand. Sidelight or view window at main entry door from a seated position	<input type="checkbox"/> No	<input type="checkbox"/> Yes
Thermostats are designed for visually impaired or have the ability to be monitored and operated with an electronic device such as a tablet computer	<input type="checkbox"/> No	<input type="checkbox"/> Yes
Majority of closets within UD units must have shelving that is adjustable OR provide multiple shelving/hanger rod configuration whereby majority of shelving/hanger rods are within one of the reach ranges of the Minnesota Accessibility Code – Section 308	<input type="checkbox"/> No	<input type="checkbox"/> Yes
An audio/visual doorbell is included at all main dwelling unit entry doors	<input type="checkbox"/> No	<input type="checkbox"/> Yes
A covered canopy with adequate lighting is provided at exterior main unit entry. An interior or exterior bench space for parcels or groceries is provided	<input type="checkbox"/> No	<input checked="" type="checkbox"/> Yes
Parking spaces for at least 50% of the UD units (rounded up to the nearest whole number). Include a five (5) foot wide adjacent auxiliary space (access aisle) connected to an accessible route	<input type="checkbox"/> No	<input type="checkbox"/> Yes
Residential elevator or chair lift space structured for future use in multiple level homes	<input type="checkbox"/> No	<input type="checkbox"/> Yes
Enterprise Green Communities Model Specifications are used for applicable sections in the UD units.	<input type="checkbox"/> No	<input type="checkbox"/> Yes
On-site accessible physical activity is provided via a fitness area, biking path, walking path or community garden	<input type="checkbox"/> No	<input checked="" type="checkbox"/> Yes
Other modifications that make units livable for disabled populations, as demonstrated with credible evidence. Approval is at the sole discretion of Minnesota Housing	<input type="checkbox"/> No	<input type="checkbox"/> Yes

*** Guidance**

Slip resistance – tile products: Use slip resistant tile with coefficient of friction of 0.60 or greater (wet) as identified by the Ceramic Tile Institute. Consider smaller or mosaic tiles on floors in wet areas to increase traction provided by grout lines and to provide greater control in establishing proper drainage slopes for floor drains. Use matt finishes in product choice to eliminate glare.

Slip resistance sheet vinyl products: Refer to a manufacturer’s enhanced slip retardant surfaces. Use matt finishes in product choice to eliminate glare.

Comments

Provide additional comments or support to answers from the questions above, as needed.

Universal Design Compliance Agreement and Certification

The Architect of Record or entity responsible for preparing the work scope, by execution of this form and by its duly authorized officers, partners or members, hereby certifies that:

1. The information contained in this document is true, correct and complete; and that
2. The execution and delivery of this project will meet requirements noted in this document.

Name of Organization | Cole Group Architects

Authorized Signature | 

Printed Name | David Majchrzak

Title | Architect

Date | 2/22/21

Minnesota Housing Finance Agency

**SUPPLEMENT TO GENERAL CONDITIONS OF THE
AGREEMENT BETWEEN OWNER AND CONTRACTOR**

THIS SUPPLEMENT TO GENERAL CONDITIONS OF THE AGREEMENT BETWEEN OWNER AND CONTRACTOR (the "MHFA Supplement") is effective as of the _____ day of _____, 20____, between _____, a _____ ("Owner"), and _____, a _____ ("Contractor"), as an inducement to the Minnesota Housing Finance Agency ("MHFA") to enter into a _____ Program Building Loan Agreement with Owner of even date herewith (the "Building Loan Agreement") pursuant to which MHFA will loan funds (collectively, the "MHFA Loan") secured by certain mortgage notes and mortgages, all of even date herewith (the "MHFA Loan Documents"). Owner will use the proceeds of the MHFA Loan to finance construction and/or rehabilitation of certain improvements on real estate located in _____ County, Minnesota (the "Project"). Owner and Contractor agree that the following provisions shall govern the agreements between Owner and Contractor notwithstanding any contrary provision in the Contract Documents, as defined in Article 1 of AIA Document A101 (1997 OR 2007) and any other supplements or other modifications thereto. This MHFA Supplement is a modification of the Contract Documents, and Owner and Contractor agree that to the extent this MHFA Supplement is inconsistent with any other modification, this MHFA Supplement shall control over the other modifications. Any capitalized terms not defined herein shall have the meanings set forth in AIA Document A101 or AIA Document A201. No term defined in the Contract Documents or this MHFA Supplement may have the definition modified without the express written consent of MHFA.

**ARTICLE I
GENERAL PROVISIONS**

1. Contractor acknowledges that it has been provided with a copy of the Building Loan Agreement and has reviewed Article II and Article III thereof. Contractor further acknowledges that MHFA is a third party beneficiary of the Contract Documents for the purpose of issuing correction orders pursuant to Section 3 hereof and has made loans under the Building Loan Agreement for which the Project is the primary source of collateral. The obligations of MHFA under the Building Loan Agreement are contingent upon and subject to the acceptance by MHFA of the Building Loan Agreement as well as the MHFA Loan Documents executed pursuant thereto. If for any reason whatsoever the Building Loan Agreement or the MHFA Loan Documents are not executed, delivered, and recorded, this MHFA Supplement shall be void and of no effect.

2. All changes in the plans or specifications prepared in connection with the construction and/or rehabilitation of the Project, which are set forth in **Exhibit A** attached hereto, or changes to any terms of the Contract Documents, or orders for extra Work, or changes by altering or adding to the Work shall be made only following completion of a written Change Order executed by Owner, the Architect, if any, and Contractor (except for MHFA's correction orders, if any, as provided below) and after the Change Order has been submitted to and placed on file with MHFA. Any changes in the Contract Documents for extra Work, or changes by altering or adding to or eliminating any of the Work that will result in any net construction cost increase or decrease, or will change the design concept, or



Contract Compliance Plan

Statement of Policy

It is the policy of the Minnesota Housing to take affirmative action to provide equal opportunity in all of our projects programs and other endeavors. The Agency's goal is to achieve a client and recipient mix that is representative of the people who live in our state and our communities, so that all employment and contractual benefits that develop as a result of our programs will be shared by all Minnesotans. This policy applies to all Agency employees and everyone with whom we do business.

Purpose

The purpose of this Plan is to make the Agency's commitment to act affirmatively to achieve equal opportunity in all facets of its operation, clear to both staff and those outside the Agency with whom we do business.

Goals

Our goal is to ensure minority and female business owners equal access to business opportunities on Minnesota Housing financed projects and the presence of minorities and women at all levels on the staffs of the program participants having contractual agreements with Minnesota Housing. The Agency's goal is to ensure that the workforces on the projects and programs we finance reflect demographically the area they are located in. Our goal is to ensure equal business opportunity to minority and female businesses on the projects we finance and equal employment opportunity in the workforces of the firms with whom we sign contractual agreements in which a contractor commits to meet the Agency's employment and business goals. These goals will apply for the length of the contract or the life of the mortgage. The Agency at its discretion may set numerical or percentage goals dependent on the location and size of a given project. Current goals will be determined by staff based on the location of the project.

Requirements

The Agency is required to comply with all state, federal and local laws. These requirements are passed on to everyone we do business with either by contractual agreement or Agency policy.

Sanctions

The Agency has the contractual authority to demand full payment of any loan or grant, stop processing any project at any stage, and to cease to do business with anyone that does not follow our affirmative action policies or fails to meet their contractual equal opportunity obligations.

¹ The operations of the Minnesota Housing Finance Agency are regulated by the following Equal Opportunity Laws/Rules:

- Executive Order 11246 (Affirmative Action Requirements, Government Contractors)
- Executive Order 11625 (Minority Business Enterprise)
- The Civil Rights Act of 1964 (Title VII)
- Equal Employment Act of 1972
- Minnesota Code of Agency Rules (Chapter 2, Sec. 3.012)
- The Americans with Disability Act of 1990
- Section 504 of The Rehabilitation Act of 1973 as amended
- Minnesota Human Rights Act (Section 363.073)
- Fair Housing Amendments Act of 1988

Responsible Persons

- ❑ **Minnesota Housing's Board of Directors** – Approves Agency Equal Opportunity Policy, Goals and Requirements, evaluates successes, imposes sanctions.
- ❑ **Commissioner** – Take direct action, directs staff, reports and recommends necessary action in specific instances to the Board.
- ❑ **Fair Housing Director** – Responsible for carrying out the Agency's equal opportunity programs and the meeting of Agency equal opportunity goals. Approves submitted materials, applies requirements, monitors projects, submits reports and makes recommendations to the Commissioner.
- ❑ **Program Managers** – Responsible for following all equal opportunity laws and the achievement of all contractual responsibilities in their program areas.
- ❑ **Project Coordinators** – Responsible for meeting all requirements in their projects.
- ❑ **Developer, Owner, Grantee, Loan Recipient** – Has the ultimate responsibility for meeting contractual requirements on their projects.
- ❑ **Prime Contractor** – Shares responsibility with developer for meeting contractual equal opportunity requirements and is also responsible for the equal opportunity performance of all subcontractors.

Contract Compliance Activity Report

Development Address		WBE (%)	MBE (%)	MBE Ethnic Code (See Appendix)	Type of Contractor (General or Sub)	Bid Accepted (%)	\$ Amt. Of Bid	# of Pos. Currently Filled	# of Women in Non-Traditional Jobs	# of Minorities Ethnic Code (See Appendix)
Contractor and City	Type of Business						\$			
							\$			
							\$			
							\$			
							\$			
							\$			
							\$			
							\$			
							\$			
Totals/Where Applicable:							\$			
Complete for All Contractors						Complete for Responding Contractors				
Property Owner Signature										Date
EEO Officer Signature										Date

The information required on the Contract Compliance Activity Report is to be provided for all contractors (i.e., Generals and sub-contractors) that were contacted for the project. The information on the back of this page is provided to assist you in responding to the information asked for in an accurate manner.

IMPORTANT CONTRACT COMPLIANCE INFORMATION AND DEFINITIONS

DEFINITIONS:

- **W/MBE** - woman or minority owned business (i.e., having 51% ownership in the actual work of the business)
- **MINORITY** - member of one of the following racial/ethnic groups:
 - BLACK/AFRICAN AMERICAN (non-Hispanic) - a person having origins in any of the black racial groups of Africa.
 - AMERICAN INDIAN or ALASKAN NATIVE - a person having origins in any of the original peoples of North and South America (including Central America), and who maintains tribal affiliation or community attachment.
 - ASIAN - a person having origins in any of the original peoples of the Far East, Southeast Asia, the Indian Subcontinent, for example: Cambodia, China, India, Japan, Korea, Malaysia, Pakistan, the Philippine, Thailand and Vietnam.
 - NATIVE HAWAIIAN OR OTHER PACIFIC ISLANDER – a person having origins in any of the original peoples of Hawaii, Guan, Samoa or Pacific Islands.
 - HISPANIC OR LATINO - a person of Cuban, Mexican, Puerto Rican, South or Central American or other Spanish culture or origin, regardless of race.
- **L.I.P.A.R.** - lower income project area residents; low-income individuals residing within units of the project receiving Section 3-covered funds, or the nonmetropolitan county where the project is located.

RACIAL/ETHNIC CODES:

- | | | |
|----------------------------|---------------------------------------|---|
| 1 - White | 3 - American Indian or Alaskan Native | 5 - Native Hawaiian or Other Pacific Islander |
| 2 - Black/African American | 4 - Asian | 6 - Hispanic or Latino |





Equal Employment Opportunity Policy Statement

Development Information	
Minnesota Housing Development Number	
Development Name	
Development Address	
Total Number of Units	
Dollar Amount of Rehab \$	Dollar Amount of Project \$

Property Owner Information	
Property Owner Name	
Phone Number	
Minority Property Owner?	<input type="checkbox"/> No <input type="checkbox"/> Yes, please enter racial/ethnic code:

Development Team Information	
Equal Opportunity Officer Name	
Phone Number	
General Contractor Name	
Phone Number	
Minority General Contractor?	<input type="checkbox"/> No <input type="checkbox"/> Yes, please enter racial/ethnic code:

Racial/Ethnic Codes						
<table style="width: 100%; border: none;"> <tr> <td style="width: 50%;">1. Black or African American</td> <td style="width: 50%;">2. Asian</td> </tr> <tr> <td>3. American Indian or Alaskan Native</td> <td>4. Native Hawaiian or Other Pacific Islander</td> </tr> <tr> <td>5. Hispanic or Latino</td> <td></td> </tr> </table>	1. Black or African American	2. Asian	3. American Indian or Alaskan Native	4. Native Hawaiian or Other Pacific Islander	5. Hispanic or Latino	
1. Black or African American	2. Asian					
3. American Indian or Alaskan Native	4. Native Hawaiian or Other Pacific Islander					
5. Hispanic or Latino						

Policy Statement
<p>I hereby certify that it is the policy of the undersigned to comply with all existing laws prohibiting discrimination in all aspects of employment due to race, color, creed, sex, age, religion, national origin, marital status, receipt of public assistance or disability. This shall be accomplished substantially by the following actions: Nondiscrimination in RECRUITING, HIRING, TRAINING, PROMOTING, SUBCONTRACTING, DEMOTION, LAYOFF, and/or TERMINATION. Whenever possible, we will also take affirmative action to include in our workforce minorities, females, and those who are disabled.</p>

Property Owner or General Contractor Signature (entity completing form)	Date

Equal Opportunity Officer Signature	Date

Minnesota Housing Finance Agency (Minnesota Housing) is committed to equal housing and equal employment opportunity. Anyone that does business with Minnesota Housing will be required to share this commitment. Equal Opportunity Housing and Equal Opportunity Employment.



Multifamily Insurance Requirements

During Construction/Substantial Rehabilitation

1. From the Owner OR General Contractor -- "All Risk" Builder's Risk Completed Value Certificate of Insurance:
 - a. In an amount not less than the amount of the Construction Contract or 100% of the insurable replacement value of such building(s) or improvements (whichever is greater);
 - b. Mortgagee clause naming Minnesota Housing Finance Agency as Mortgagee;
 - c. Loss Payee clause naming Minnesota Housing Finance Agency as Loss Payee;
 - d. Replacement Cost Valuation Basis;
 - e. Must include an Agreed Value Clause (no co-insurance penalty applicable);
 - f. If applicable, Boiler and Machinery Coverage (no co-insurance);
 - g. Flood Insurance, if applicable: in an amount equal to the lesser of the current amount of the Minnesota Housing loan(s) or the maximum limit of coverage under the Biggert-Waters Flood Insurance Reform Act of 2012;
 - h. Insurer will provide Minnesota Housing with 30 days prior written notice in the event of cancellation, non-renewal or material change;
 - i. Insurer must be authorized to transact business in the State of Minnesota and must have a Best's rating of A- or better (refer to www.ambest.com for rating information).
2. From the Owner AND General Contractor -- Comprehensive General Liability Certificate of Insurance (including operations, contingent liability, operations of subcontractors, completed operations and contractual liability insurance):
 - a. Limits against bodily injury and property damage of not less than \$1,000,000 per occurrence and \$3,000,000 in aggregate. An umbrella excess liability policy may be used to meet such requirements;
 - b. Minnesota Housing Finance Agency named as an Additional Insured;
 - c. Insurer will provide Minnesota Housing with 30 days prior written notice in the event of cancellation, non-renewal or material change;
 - d. Insurer must be authorized to transact business in the State of Minnesota and must have a Best's rating of A- or better (refer to www.ambest.com for rating information).
3. From the General Contractor -- Worker's Compensation Insurance:
 - a. In the statutory amount;
 - b. Insurer will provide Minnesota Housing with 30 days prior written notice in the event of cancellation, non-renewal or material change;
 - c. Insurer must be authorized to transact business in the State of Minnesota and must have a Best's rating of A- or better (refer to www.ambest.com for rating information).
4. From the Architect -- Professional Liability Insurance Certificate:
 - a. In an amount not less than \$500,000 per occurrence. In cases where the design and supervising architects are different entities, each entity shall supply a certificate of insurance of professional liability insurance in an amount not less than \$500,000.

Existing/Completed Buildings

1. From the Owner -- "Special Form" or "All-Risk" Hazard Certificate of Insurance:
 - a. In an amount not less than the amount of Minnesota Housing's outstanding financing or 100% of the insurable replacement value of such building(s) or improvements (whichever is greater). *If rehabilitation is occurring, then an overlap endorsement or rider insuring the rehabilitation work to be completed must be included;*
 - b. Mortgagee clause naming Minnesota Housing Finance Agency as Mortgagee;
 - c. Loss Payee clause naming Minnesota Housing Finance Agency as Loss Payee;
 - d. Replacement Cost Valuation Basis;
 - e. Must include an Agreed Value Clause (no co-insurance penalty applicable);
 - f. If applicable, Boiler and Machinery Coverage (no co-insurance);
 - g. Flood Insurance, if applicable: in an amount equal to the lesser of the current amount of the Minnesota Housing loan(s) or the maximum limit of coverage under the Biggert-Waters Flood Insurance Reform Act of 2012;
 - h. Insurer will provide Minnesota Housing with 30 days prior written notice in the event of cancellation, non-renewal or material change;
 - i. Insurer must be authorized to transact business in the State of Minnesota and must have a Best's rating of A- or better (refer to www.ambest.com for rating information).

2. From the Owner -- Comprehensive General Liability Certificate of Insurance (including operations, contingent liability, operations of subcontractors, completed operations and contractually liability insurance):
 - a. Limits against bodily injury and property damage of not less than \$1,000,000 per occurrence and \$3,000,000 in aggregate. An umbrella excess liability policy may be used to meet such requirements;
 - b. Minnesota Housing Finance Agency named as an Additional Insured;
 - c. Insurer will provide Minnesota Housing with 30 days prior written notice in the event of cancellation, non-renewal or material change;
 - d. Insurer must be authorized to transact business in the State of Minnesota and must have a Best's rating of A- or better (refer to www.ambest.com for rating information).

For properties receiving first mortgage financing from Minnesota Housing- Owner shall submit a statement showing the annual premium amount and evidence that the current year insurance premium is paid in full. Payment plan with Insurer is not acceptable. Annual premiums are escrowed with Minnesota Housing on a monthly basis.

Owner's insuring the mortgaged property under a blanket policy must list the Total Insured Value of the mortgaged property on the face of the Insurance Certificate.

Construction Commitment Letter

To be printed on contractor's letterhead.

(Date)

(Owner Name and
Address)

and

Minnesota Housing Finance Agency
Suite 300
400 Sibley Street
St. Paul, MN 55101

ATTN: Assistant Commissioner, Multifamily

RE: CONSTRUCTION COMMITMENT
MHFA Form #214
(Name of Development)
(Location of Development)

Ladies and Gentlemen:

(Name of Owner) (hereinafter called "Owner") has selected this firm as general contractor for the above referenced development.

We are prepared to build this development for \$ _____ based upon drawings and specifications prepared by (Name of Architectural Firm) and dated _____, and addenda number(s) _____ dated _____ (list all addenda and their respective dates). The completed MHFA Form of Contractor's and/or Mortgagor's Cost Breakdown is attached.

Our price is based on a construction start date of (month/day/year) with the construction period being _____ calendar days, substantial construction completion scheduled for (month/day/year), and final construction completion scheduled for (month/day/year).

Included in the construction price are all sums for construction including labor, materials, general requirements, overhead, profit, sales tax, and all other fees and charges payable to the contractor under the AIA Construction Contract and MHFA Supplement to General Conditions of the Agreement Between Owner and Contractor.

We understand that the MHFA Supplement to General Conditions of the Agreement between Owner and Contractor also requires a Contractor's Cost Certification prepared by an independent Certified Public Accountant and that our payment for the work under this contract will be the lesser of:

- a) The Total Construction Cost shown as the Construction Contract Amount on the Development Costs tab of the Multifamily Workbook, dated _____, plus approved Change Orders.
- b) The Cost Certified amount.

Cost of Payment and Performance Bonds, Building Permits and Builder's Risk Insurance (*is or is not*) included in the construction price.

We do hereby represent that our bonding company (*Name of Company*) is ready to issue 100% payment and performance bonds on this job in form acceptable to MHFA.

We have reviewed and stand ready to execute the MHFA Supplement to General Conditions of the Agreement Between Owner and Contractor, and the Contractor's Acknowledgement and Consent to Assignment of Construction Contract.

(*Name of Authorized Signer and their Title*) is authorized to execute the MHFA's Agreements on behalf of (*Construction Company Name*) a _____ company.

Very truly yours,

(LEGAL NAME OF CONTRACTOR)

BY: _____

Minnesota Housing Finance Agency

ASSIGNMENT OF CONSTRUCTION CONTRACT

This Assignment is effective as of the ____ day of _____, 20____, between _____, a _____ ("Borrower"), and the Minnesota Housing Finance Agency, a public body corporate and politic of the State of Minnesota ("MHFA").

RECITALS

(TO BE USED WITH NOTE AND MORTGAGE)

A. Borrower and MHFA have entered into a Minnesota Housing Finance Agency Building Loan Agreement, of even date herewith (the "Building Loan Agreement"), under which MHFA has agreed to make advances to Borrower not exceeding the principal amount of \$_____ (the "Loan") in accordance with the terms thereof to finance construction of certain improvements as shown in the drawings and specifications prepared by _____ as set forth in Exhibit A hereto (the "Project"), to be constructed on real estate located in _____ County, Minnesota. The Loan will be evidenced by a Minnesota Housing Finance Agency _____ Program Mortgage Note and a Minnesota Housing Finance Agency _____ Program Mortgage Note, [if adding multiple program Notes, then change the word "both" to "all"] both of even date herewith, payable to the order of MHFA in the total original principal amount of \$_____ (collectively, the "Note").

B. To secure payment of the Note, Borrower has executed and delivered to MHFA a Minnesota Housing Finance Agency _____ Program Assignment of Rents and Leases and a Minnesota Housing Finance Agency _____ Program Assignments of Rents and Leases [if adding multiple program Assignment of Rents and Leases, then change the word "both" to "all"], both of even date herewith, covering the rents and leases affecting the Project, and a Minnesota Housing Finance Agency _____ Program Combination Mortgage, Security Agreement, and Fixture Financing Statement and a Minnesota Housing Finance Agency _____ Program Combination Mortgage, Security Agreement, and Fixture Financing Statement, [if adding multiple program Mortgages, then change the word "both" to "all"], both of even date herewith, covering certain property, which, among other things, includes the real estate upon which the Project is to be constructed (the "Real Estate") and the buildings, improvements, fixtures and personal property now or hereafter located thereon.

(USE PARAG. B, BELOW FOR HTF 501C 3)

B. To secure payment of the Note, Borrower has executed and delivered to MHFA a Minnesota Housing Finance Agency Housing Trust Fund Program Combination Mortgage, Security Agreement, Assignment of Rents and Leases and Fixture Financing Statement, of even date herewith, covering the rents and leases affecting the Project and covering certain property, which, among other things, includes the real estate upon which the Project is to be constructed (the "Real Estate") and the buildings, improvements, fixtures and personal property now or hereafter located thereon.

OR

(TO BE USED WITH REPAYMENT AGREEMENT)

A. Borrower and MHFA have entered into a Minnesota Housing Finance Agency Building Loan Agreement, of even date herewith (the "Building Loan Agreement"), under which MHFA has agreed to make advances to Borrower not exceeding the principal amount of \$_____ (the "Loan") in accordance with the terms thereof to finance construction of certain improvements as shown in the drawings and specifications prepared by _____ as set forth in **Exhibit A** hereto (the "Project"), to be constructed on real estate located in _____ County, Minnesota. The Loan will be evidenced by a Minnesota Housing Finance Agency _____ Program Loan Repayment Agreement and Mortgage, of even date herewith, between Borrower and MHFA (the "Repayment Agreement")

B. To secure payment of the Loan, Borrower has executed and delivered to MHFA, in the Repayment Agreement, a mortgage covering certain property, which, among other things, includes the real estate upon which the Project is to be constructed (the "Real Estate") and the buildings, improvements, fixtures and personal property now or hereafter located thereon.

C. MHFA has required, as a condition to making any advances under the Building Loan Agreement, the execution hereof by Borrower and the acknowledgment and consent hereto by the Contractor.

ACCORDINGLY, in consideration of the foregoing, Borrower grants, assigns, transfers and sets over unto MHFA all of its right, title and interest in and to the construction contract, together with all addenda thereto (the "Contract"), dated _____, between Borrower, as the Owner, and _____ (the "Contractor") for construction of the Project, true and correct copies of which have been delivered to MHFA this date. The drawing and specifications set forth in **Exhibit A**, together with the Contract, constitute the "Contract Documents".

1. Borrower agrees that MHFA does not assume any of the obligations or duties of Borrower under or with respect to the Contract unless and until MHFA shall have given the Contractor written notice that it has affirmatively exercised its right to complete or cause the completion of construction of the Project following the occurrence of an Event of Default under the Building Loan Agreement. If MHFA does not personally undertake to complete construction, MHFA shall have no liability whatsoever for the performance of any of such obligations and duties. For the purpose of completing the Project, MHFA may, in its absolute discretion, reassign its right, title and interest in the Contract upon notice to the Contractor but without any requirement for Borrower's consent.

2. Borrower represents and warrants that there have been no prior assignments of the Contract, [except as set forth in that certain Master Subordination Agreement and Estoppel Certificate dated of even date herewith, (the "MSA")] that the Contract is a valid, enforceable agreement, that none of the parties is in default thereunder, and that all covenants, conditions and agreements have been performed as required therein except those not due to be performed until after the date hereof. Borrower agrees that no change in the terms thereof shall be valid without the written approval of MHFA. Borrower agrees not to assign, sell, pledge, mortgage or otherwise transfer or encumber its interest in the Contract so long as this Assignment is in effect.

3. Borrower hereby irrevocably constitutes and appoints MHFA as its attorney-in-fact to demand, receive, and enforce Borrower's rights with respect to the Contract, to make payments under the Contract and give appropriate receipts, releases and satisfactions for and on behalf of and in the name of Borrower or, at the option of MHFA, in the name of MHFA, with the same force and effect as Borrower could do if this Assignment had not been made.

4. This Assignment shall constitute a perfected, absolute and present assignment, provided that MHFA shall have no right under this Assignment to enforce the provisions of the Contract until an Event of Default shall occur under the Building Loan Agreement or Borrower shall be in default under the [Note/Repayment Agreement] or under any other instrument, document or agreement related to the Project. This Assignment shall remain in effect until all rights of the Owner under the Contract, including any warranties, have expired. Upon the occurrence of any such default or Event of Default, MHFA may, without affecting any of its rights or remedies against Borrower under any other instrument, document or agreement, exercise its rights under this Assignment as Borrower's attorney-in-fact in any manner permitted by law, and in addition, MHFA shall have the right to exercise and enforce any or all rights and remedies available after default to a secured party under the Uniform Commercial Code, as adopted in the State of Minnesota. If notice to Borrower of any intended disposition of the collateral or any other intended action is required by law in a particular instance, such notice shall be deemed commercially reasonable if given at least 10 days prior to the date of intended disposition or other action.

5. Borrower agrees to pay all costs and expenses (including, without limitation, reasonable attorney's fees) that MHFA may incur in exercising any of its rights under this Assignment.

6. Subject to the aforesaid limitation on further assignment by Borrower, this Assignment shall be binding upon Borrower, its heirs, representatives, assigns and successors, and shall inure to the benefit of MHFA, its successors and assigns.

7. This Assignment may be waived, modified, amended, terminated or discharged only explicitly in a writing signed by MHFA. A waiver signed by MHFA shall be effective only in a specific instance and for the specific purpose given. Mere delay or failure to act shall not preclude the exercise or enforcement of any of MHFA's rights or remedies hereunder. All rights and remedies of MHFA shall be cumulative and may be exercised singularly or concurrently, at MHFA's option, and the exercise or enforcement of any one such right or remedy shall neither be a condition to nor bar the exercise or enforcement of any other.

IN WITNESS WHEREOF, Borrower has executed this Assignment as of the day and year first above written.

a _____

By: _____
a _____
General Partner

By: _____

Its: _____

CONTRACTOR'S ACKNOWLEDGMENT AND CONSENT

In consideration of MHFA's making the construction loan to Borrower described in the foregoing Assignment, the undersigned Contractor hereby consents to the foregoing Assignment and acknowledges and agrees with MHFA as follows:

1. The Contractor has entered into the Contract with Borrower whereby the Contractor has agreed to act as the general contractor in connection with construction of the Project.

2. The Contract is in full force and effect, has not been modified or assigned, [except as set forth in the MSA,] and no event has occurred or failed to occur as of the date hereof which, but for the passage of time, the giving of notice or both, would be a default thereunder.

3. Upon the occurrence of an Event of Default under the Building Loan Agreement, the Contractor shall, at MHFA's written request, continue performance on MHFA's behalf under the Contract in accordance with the terms thereof, provided that MHFA agrees in writing to assume and promptly perform all of Borrower's obligations under the Contract necessary for the continued performance of the Work and completion of the Project, including, but not limited to, reimbursing the Contractor in accordance with the Contract for all work, labor and materials rendered on MHFA's behalf.

4. The disbursement provisions contained in the Building Loan Agreement and the Disbursement Agreement referred to in the Building Loan Agreement shall control the disbursement of loan funds to Borrower notwithstanding any conflicting provisions contained in the Contract.

5. After the MHFA has satisfied the condition contained in Section 3 above, MHFA may enforce the obligations of the Contract with the same force and effect as if enforced by Borrower and may, at any time, perform the obligations of Borrower, and the Contractor will accept such performance in lieu of performance by Borrower in satisfaction of Borrower's obligations thereunder.

6. The Contractor will give MHFA prompt written notice of any default by Borrower under the Contract.

7. The Contractor will not terminate the Contract on account of any default of Borrower thereunder without written notice of such default to MHFA and providing MHFA 30 days to cure the default or to commence completion of construction of the Project. However, unless MHFA elects to complete construction of the Project pursuant to Section 3 above, nothing herein shall require MHFA to cure any default of Borrower under the Contract.

8. The officer signing this consent on behalf of the Contractor hereby certifies that the undersigned has full authority under all state and local laws and regulations to perform all of its obligations under the Contract in accordance with the terms thereof and that the Contractor will comply with all applicable laws and regulations, local, state and federal, in performing such obligations. Upon completion of the Project, the Contractor will certify to MHFA, and to any assignee of the loans made by MHFA under the Building Loan Agreement, that the Project has been completed in substantial accordance with the drawings and specifications set forth in **Exhibit A**.

9. All notices shall be in writing and shall be sent to the respective addresses of the parties as follows:

MHFA: Minnesota Housing Finance Agency
400 Sibley Street, Suite 300
St. Paul, MN 55101
ATTN: Assistant Commissioner, Multifamily
Telephone: (651) 296-3724
Facsimile: (651) 296-9545

CONTRACTOR: _____

ATTN: _____
Telephone: _____
Facsimile: _____

10. Notwithstanding anything herein to the contrary, nothing herein shall be construed to release or waive any of the Borrower's obligations or liability to the Contractor under the Contract and/or applicable law.

Dated as of _____

a _____

By: _____

Its: _____

EXHIBIT A
DRAWINGS AND SPECIFICATIONS

PAYMENT BOND

KNOW ALL BY THESE PRESENTS, that we, _____
_____, a _____
_____, as Principal (hereinafter called "Principal"), and
_____, as Surety
(hereinafter called "Surety"), are held and firmly bound unto _____
_____, a Minnesota _____, with its
offices located at _____,
(hereinafter called the "Owner-Obligee"), and the Minnesota Housing Finance Agency, 400 Sibley St.,
Suite 300, St. Paul, MN, 55101-1998, (hereinafter called the "Lender-Obligee"), as their respective
interests may appear, in the amount of
_____ Dollars
(\$ _____) lawful money of the United States of America, for the payment whereof Principal
and Surety bind themselves, their heirs, executors, administrators, successors, and assigns, jointly and
severally, firmly by these presents.

WHEREAS, Principal has entered or will enter into a Construction Contract (hereinafter called
the "Contract"), a copy of which is attached and made a part hereof, with the Owner-Obligee requiring
approval of the Lender-Obligee for the construction of a development designated as
_____, a copy of which Contract is by reference
made a part hereof; and

WHEREAS, Lender-Obligee, under a certain Building Loan Agreement, a copy of which is
attached and made a part hereof, has agreed or will agree to lend to the Owner-Obligee a sum of
money to be secured by a mortgage on said development and to be used by the Owner-Obligee in
making payments to the Principal under said Contract, and the Obligees desire assurance of the prompt
payment by Principal for all labor and materials furnished in the prosecution of the work provided for in
the Contract.

NOW, THEREFORE, THE CONDITION OF THIS OBLIGATION IS SUCH, that if the Principal shall
promptly make payment to all claimants, as hereinafter defined, for all labor and material furnished in
the prosecution of the work provided for in the Contract, then this obligation shall be void; otherwise, it
shall remain in full force and effect. A claimant, as hereinafter defined, shall have a direct right of action
hereunder against the Surety, subject to the following conditions:

1. A claimant is defined as one having a direct contract with the Principal or with a
subcontractor of the Principal who has furnished labor, material, or both, in the prosecution of the work
provided for in the Contract and who has not been paid in full therefore. Labor and material include,

but are not limited to, that part of water, gas, power, light, heat, oil, gasoline, telephone service, or rental of equipment directly applicable to the performance of the Contract.

2. The above-named Principal and Surety hereby jointly and severally agree with the Obligees that every claimant as herein defined, who has not been paid in full before the expiration of a period of one hundred twenty (120) days after the date on which the last of such claimant's work or labor was done or performed or materials were furnished by such claimant, may sue on this bond in the name of the claimant, prosecute the suit to final judgment for such sum or sums as may be justly due claimant and have execution thereon; provided, however, that the Obligees hereunder shall not be liable for the payment of any costs or expenses of any such suit.

3. The prior written approval of Surety shall be required with regard to any changes or alterations in said Contract where the cost thereof, added to prior changes or alterations, causes the aggregate cost of all changes and alterations to exceed 10 percent of the original Contract price; but, except as to the foregoing, any alterations which may be made in the terms of the Contract or Building Loan Agreement, or in the work to be done under it, or the giving by Obligees of any extension of time for the performance of the Contract, or any other forbearance on the part of either the Obligees or Principal to the Contract, or any other forbearance on the part of either the Obligees or Principal to the other, shall not in any way release Surety or Principal of the obligations of this instrument, notice to Surety of any such alterations, extension, or forbearance being hereby waived.

4. No suit or action shall be commenced hereunder by any claimant:

(a) Unless the claimant shall have: (i) given written notice of claim to any two of either the Principal or either of the Obligees within the period of time specified in condition 2, above; or (ii) filed a mechanic's lien in accordance with the Mechanic's Lien Act of Minnesota. The notice of claim required by (i), above, shall state with substantial accuracy the amount claimed and the name of the party to whom materials were furnished, or for whom the work or labor was done or performed; and, be served by mailing the same by registered or certified mail, postage prepaid and envelopes addressed to the Principal or to either of the Obligees at any place where an office is regularly maintained by the addressee for the transaction of business, or served in any manner in which summons or subpoena may be served under Minnesota law in the place in which the aforesaid development is located, save that such service need not be made by a public officer. For the purpose of this condition 4(a), the filing of a mechanic's lien, in accordance with the Mechanic's Lien Act of Minnesota is a sufficient notice hereunder.

(b) After the expiration of two (2) years following the date on which Principal ceases work under the Contract.

(c) Other than in a district court of Minnesota of competent jurisdiction in and for the county in which the development, or any part thereof, is situated, or in the United States District Court for the district in which the development, or any part thereof, is situated and not elsewhere.

5. The amount of this bond shall be reduced by and to the extent of any payment or payments made in good faith hereunder, inclusive of the payment by Surety of liens which may be filed of record on account of any labor or material furnished under the Contract, whether or not claim for the amount of such lien be presented under and against this bond.

6. The Principal and Surety shall not be liable under this Bond to the Obligees, or either of them, unless the said Obligees, or either of them, shall make payments to the Principal prior to default and the Surety after default in accordance with the terms of the Contract and Building Loan Agreement as to payments, and shall perform all other obligations to be performed under the Contract and Building Loan Agreement at the time and in the manner therein set forth.

SIGNED AND SEALED this _____ day of _____, 20____.

ATTEST:

By: _____
(Principal)

Its: _____

ATTEST:

By: _____
(Surety)

Its: _____

STATE OF MINNESOTA)

) ss.

COUNTY OF)

The foregoing instrument was acknowledged before me this ____ day of _____ 20__ by
_____, the _____ of
_____, a Minnesota
_____, on behalf of said _____.

Notary Public

STATE OF MINNESOTA)

) ss.

COUNTY OF)

The foregoing instrument was acknowledged before me this ____ day of _____ 20__ by
_____, the _____ of
_____, a Minnesota _____, on behalf of
said _____.

Notary Public

The following supplements modify, change, delete from or add to the "General Conditions of the Contract for Construction", AIA Document A201, current edition. Where any Article of the General Conditions is modified or any Paragraph, Subparagraph or Clause thereof is modified or deleted by these Supplementary Conditions, and unaltered provisions or that Article, Paragraph, Subparagraph or Clause shall remain in effect.

1.1 Definitions

1.1.3 Add the following clause:

1.1.3.1 Use of the words "produce", "provide", "furnish" or "install" where appropriate shall also include "furnish and install".

2.2 Information and Services Required of the Owner

2.2.5 Add the following Clause:

2.2.5.1 Additional sets will be available as outlined under Instructions to Bidders. Distribution of sets shall be done by the Contractor.

3.4 Labor and Materials

Add the following Subparagraphs 3.4.4 and 3.4.6 to 3.4;

3.4.4 After the Contract has been executed, the Owner and the Architect will consider a formal request of the substitution of products in place of those specified only under the conditions set forth in the General Requirements (Division 1 of the Specifications).

3.4.5 By making requests for substitutions based on Subparagraph 3.4.4 above, the Contractor:

1. Requests that the Contractor has personally investigated the proposed substitute product and determined that it is equal or superior in all respects to that specified;
2. Represents that the Contractor will provide the same warranty for the substitution that the Contractor would for that specified;
3. Certifies that the cost data presented is completed and includes all related costs under this Contract except that the Architect's redesign costs, and waives all claims for additional costs related to the substitution which subsequently became apparent; and
4. Will coordinate the installation of the accepted substitute, making such changes as may be required for the Work to be complete in all respects.

3.7 Permits, Fees, Notices and Compliance Laws

3.7.1 Add: These also include, but are not limited to: water and sewer access charges, SWPPP permit, right – of – way utility permit, driveway/ sidewalk permit and building permits.

7.3 Construction Change Directives

7.3.6 In the first sentence, delete the words "a reasonable allowance for overhead and profit" and substitute "an allowance for overhead and profit in accordance with Clauses 7.3.10.1 through 7.3.10.6 below:

Add the following Subparagraph 7.3.10 to 7.3:

7.3.10 In Subparagraph 7.3.6, the allowance for the combined overhead and profit included in the total cost to the Owner shall be based on the following schedule:

1. For the Contractor, for Work performed by the Contractor's own forces, 10 percent of the cost.
2. For the Contractor, for Work performed by the contractor's Subcontractor, 5 percent of the amount due the Subcontractor.
3. For each Subcontractor or Sub-subcontractor involved, for Work performed by that Subcontractor's or Sub-subcontractor's own forces, 10 percent of the cost.
4. For each Subcontractor, for Work performed by the Subcontractor's Sub-subcontractors, 5 percent of the amount due the Sub-subcontractor.
5. Cost to which overhead and profit is to be applied shall be determined in accordance with Subparagraph 7.3.6.
6. In order to facilitate checking of quotations for extras or credits, all proposals, except those so minor that their propriety can be seen by inspection, shall be accompanied by a complete itemization of costs including labor, materials, and Subcontracts. Labor and materials shall be itemized in the manner prescribed above. Where major cost items are Subcontracts, they shall be itemized also.

9.3 Application for Payment

9.3.1 Add the following clause:

9.3.1.1 Retainage on payments will be ten percent (10%) of the amount claimed as "Total Combined & Stored to Date". At the time of substantial completion the Owner may reduce the retainage to five (5) times the value of the uncompleted work.



332 Minnesota Street
Suite 1650W
Saint Paul, MN 55101
Office 651-221-1997
Toll-free 800-277-2258
Fax 651-221-1904
www.GMHF.com

Insurance Requirements

Construction

From the Owner OR General Contractor

"All Risk" Builder's Risk Completed Value Certificate of Insurance

In an amount not less than the amount of the Construction Contract or 100% of insurable

- a) Replacement value of such building(s) or improvements (whichever is greater);
- b) Mortgagee clause naming "Greater Minnesota Housing Fund" as Mortgagee;
- c) Loss Payee clause naming "Greater Minnesota Housing Fund" as Loss Payee;
- d) Replace Cost Valuation Basis;
- e) Must include an Agreed Value Clause (or no co-insurance);
- f) If applicable, Boiler and Machinery Coverage (no co-insurance);
- g) Flood Insurance, if applicable, in the amount equal to the lesser of the current amount of the Greater Minnesota Housing Fund loan(s) or the maximum limit of coverage under the Biggert-Waters Flood Insurance Reform Act of 2012

From the Owners AND General Contractor

"Comprehensive General Liability Certificate of Insurance" (including operations, contingent liability, operations of subcontractors, completed operations and contractual liability insurance):

- a) Limits against bodily injury and property damage of not less than \$1,000,000 per occurrence and \$2,000,000 in aggregate. An umbrella excess liability policy may be used to meet such requirements.
- b) "Greater Minnesota Housing Fund" named as an Additional Insured

From Architect

"Professional Liability Certificate of Insurance"

- a) In an amount not less than \$500,000 per occurrence. In cases where the design and supervising architects are different entities, each entity shall supply a certificate of insurance of professional liability insurance in an amount not less than \$500,000
- b) "Greater Minnesota Housing Fund" named as an Additional Insured

Existing / Completed Buildings

From Owner

"Special Form" or "All Risk" Hazard Certificate of Insurance"

- a) In an amount not less than the amount of the outstanding finance or 100% of the insurance replacement value of such building(s) (whichever is greater). *If rehabilitation is occurring, then an overlap endorsement or rider insuring the rehabilitation work to be completed must be included;*
- b) Mortgagee clause naming "Greater Minnesota Housing Fund" as Mortgagee;



332 Minnesota Street
Suite 1650W
Saint Paul, MN 55101
Office 651-221-1997
Toll-free 800-277-2258
Fax 651-221-1904
www.GMHF.com

- c) Loss Payee clause naming "Greater Minnesota Housing Fund" as Loss Payee;
- d) Replacement Cost Valuation Basis;
- e) Must include Agreed Value Clause (or no co-insurance)
- h) If applicable, Boiler and Machinery Coverage (no co-insurance);
- i) Flood Insurance, if applicable, in the amount equal to the lesser of the current amount of the Greater Minnesota Housing Fund loan(s) or the maximum limit of coverage under the Biggert-Waters Flood Insurance Reform Act of 2012

From the Owner

"Comprehensive General Liability Certificate of Insurance" (including operations, contingent liability, operations of subcontractors, completed operations and contractual liability insurance);

- a) Limits against bodily injury and property damage of not less than \$1,000,000 per occurrence and \$2,000,000 in aggregate. An umbrella excess liability policy may be used to meet such requirements.
- b) "Greater Minnesota Housing Fund" named as an Additional Insured

11.1 Contractor's Liability Insurance

11.1.1 Add to subparagraph 11.1.1 in the first line following the word "maintain" insert the words "in a company of companies licensed to do business in the State in which the Project is located."

11.1.1.1 Delete the semicolon at the end of Clause 11.1.1.1 and add: Including private entities performing Work at the site and exempt from the coverage on account of number of employees of occupation, which entities shall maintain voluntary compensation coverage at the same limits specified for mandatory coverage for the duration of the project:

11.1.1.2 Delete the semicolon at the end of Clause 11.1.1.2 and add: Or persons or entities excluded by statute from the requirements of Clause 11.1.1.1 but required by the Contract Documents to provide the insurance required by that Clause:

11.1.1.8 Liability Insurance shall include all major divisions of coverage and be on a comprehensive basis including:

1. Premises Operations (including X, C and U coverages as applicable.)
2. Independent Contractor's Protective.
3. Products and Completed Operations.
4. Personal Injury Liability with Employment Exclusion deleted.
5. Contractual, including specified provisions for Contractor's obligation under Paragraph 3.18.
6. Owner, non-owned and hired motor vehicles.
7. Broad Form Property Damage including Completed Operations.

11.1.1.9 If the General Liability coverages are provided by a Commercial General Liability Policy on a claims-made basis, the policy date or Retroactive Date shall predate the Contract; the termination date of the policy or applicable extended reporting period shall be no earlier than the termination date of coverages required to be maintained after final payment, certified in accordance with Subparagraph 9.10.2.

Add the following Clause 11.1.2.1 to 11.1.2:

11.1.2.1 The insurance required by Subparagraph 11.1.1 shall be written for not less than the following limits, or greater if required by law:

1. Worker's Compensation:
 - a. State: Statutory
 - b. Applicable Federal Statutory (e.g. Longshoreman's)
 - c. Employer's Liability Statutory
2. Comprehensive General Liability (including Premises-Operations; Independent Contractor's Protective; Products and Completed Operations; Broad Form Property Damage):
 - a. Bodily Injury: \$500,000 Each person \$500,000 Each Occurrence
 - b. Property Damage: \$200,000 Each Occurrence
 - c. Products and completed Operations to be maintained for one year after final payment.
 - d. Property Damage Liability Insurance will provide X, C or U coverage as applicable.
 - e. Broad Form Property Damage Coverage shall include completed operations.
3. Contractual Liability: Bodily Injury and Property Damage: \$500,000 Each Occurrence
4. Personal Injury, with Employment Exclusion deleted: \$1,000,000 Annual Aggregate
5. Business Automobile Liability (including owned, non-owned and hired vehicles):
6. Commercial Umbrella (Following Form): \$1,000,000 limit

11.1.4.1 The Contractor shall furnish one copy of each of the Certificate of Insurance herein required for each copy of the Agreement which shall specifically set forth evidence of all coverage required by Subparagraphs 11.1.1, 11.1.2 and 11.1.3.

The form of the Certificate shall be an Accord Form with name of project and listing. The Contractor shall furnish to the Owner copies of any endorsements that are subsequently issued amending coverage or limits.

Architects and engineers are also insured. The "ENDEAVOR" and "BUT FAILURE TO MAIL SUCH NOTICE SHALL IMPOSE NO OBLIGATION OR LIABILITY OF ANY KIND UPON THE COMPANY, ITS AGENTS OR REPRESENTATIVES", shall be struck out of the cancellation clauses.

Insurance Certificates will be returned until this request is executed.

11.3 Property Insurance

Add the following Clause:

11.3.1.1 The form of policy for this coverage shall be completed value.

11.3.7 Delete subparagraph as written and substitute the following:

11.3.7 The Owner and Contractor waive all rights against (1) each other and the Subcontractors, agents and employees each of the other, and (2) the Architect/Engineer, his consultants and separate contractors, if any, and any of their sub-contractors, sub-subcontractors, agents and employees, for damages caused by fire or other perils to the extent covered by insurance obtained pursuant to this Paragraph 11.3 or any other property insurance applicable to the Work, except such rights as they may have to the proceeds of such insurance held by the Owner as trustees. The foregoing waiver afforded the Architect/Engineer, his agents and employees shall not extend to the liability imposed by Subparagraph 3.18.3. The Owner or the Contractor, as appropriate, shall require of the Architect/Engineer, separate contractors, Sub-contractors and Sub-subcontractors by appropriate agreements, written where legally required for validity, similar waivers, each in favor of all other parties enumerated in this Subparagraph 11.3.7.

11.4 Performance Bond and Payment Bond

Delete Subparagraph 11.4.1 and substitute the following:

11.4.1 The constructor shall furnish bonds covering faithful performance of the contract and payment of obligations rising thereunder. Bonds may be obtained through the Contractor's usual source and the cost thereof shall be included in the Contract Sum. The amount of each bond shall be equal to 100 percent of the Contract Sum.

11.4.1.1 The Contractor shall deliver the required bonds to the owner not later than three days following the date the Agreement is entered into, or if the Work is to be commenced prior thereto in response to a letter of intent., the Contractor shall, prior to the commencement of the Work, submit evidence satisfactory to the Owner that such bonds will be furnished.

11.4.1.2 The Contractor shall require the attorney-in-fact who executes the required bonds on behalf of the surety to affix thereto a certified and current copy of the power of attorney.

ARTICLE 14. TERMINATION OR SUSPENSION OF THE CONTRACT**14.2 TERMINATION BY THE OWNER FOR CAUSE**

14.2.2 Delete "seven days' written notice". Insert in its place "three (3) days' written notice".

Add the following Paragraph 14.4 to Article 14:

14.4 TERMINATION BY THE OWNER FOR CONVENIENCE

14.4.1 The Owner may, at any time, terminate the Contract for the Owner's convenience and without cause.

14.4.2 Upon receipt of written notice from the Owner of such termination for the Owner's convenience, the Contractor shall:

1. Cease operations as directed by the Owner in the notice
2. Take actions necessary, or that the Owner may direct, for the protection and preservation of the work; and
3. Except for the work directed to be performed prior to the effective date of termination stated in the notice, terminate all existing Subcontracts and purchase orders and enter into no further Subcontracts and purchase orders.

14.4.3 In case of such termination for the Owner's convenience, the Contractor shall be entitled to receive payment from the Owner in the same basis provided in Subparagraph 14.1.2.

1.1 SCOPE

A. Conditions of the Contract, Division O, and General Requirements, Division 1, will govern work under this Section.

B. The following Special Conditions modify, define, change, delete from, add to and take precedence over certain provisions of the General Conditions of the Contract for Construction, and Supplementary General Conditions.

1.2 SPECIAL CONDITIONS OF THE CONTRACT FOR CONSTRUCTION TIME OF COMPLETION AND LIQUIDATED DAMAGES

A. If the Work is not Substantially Complete on or before the date specified by Exhibit __ for the issuance of a temporary certificate of occupancy, or other date as granted by a fully executed Change Order, the Contractor shall pay to the Owner as liquidated damages the sum of \$15,000 the first day and \$500 for each additional day calendar day of delay. If a temporary certificate of Occupancy is not approved by the 1st day of the month following the completion date, or other date as granted by a fully executed Change Order, the Contractor shall pay the Owner as liquidated damages an additional \$30,000, and an additional \$30,000 for each following month until a temporary certificate of occupancy is approved as of the first day of the month (June 1, July 1, etc).

B. If the Work has not reached Final Completion, as defined by the Contract, on or before the date specified By Exhibit ____, or other date as granted by a fully executed change order, the Contractor shall pay to the Owner as liquidated damages, the sum of \$15,000 the first day and \$500 for each additional calendar day of delay. Any monies due to the Owner as liquidated damages will be deducted from any monies due or to become due to the Contractor under the Contract. If the amount of liquidated damages owed to the Owner exceed the amount due or to become due to the Contractor, Owner may seek payment of the excess amount from Contractor or Contractor's surety.

The Architect and/or Engineer of Record (A/E) may prepare and issue Addenda during the bidding period as necessary to interpret or clarify the bidding documents, to list approved substitutions of materials or systems or to change the date or time for receipt of bids.

Addenda will refer bidders to the affected drawings or section of the Project Manual and describe the modification, clarification or correction in writing or by means of supplemental drawings, if necessary.

Addenda will be serially numbered and dated, will identify Project, Owner and A/E and will reiterate the date and time of bid opening or state new date and time of bid opening, if changed.

Addenda will be distributed by email to all known bidders at the address furnished by them when bidding documents were obtained.

Copies of the Addenda will be distributed at the same time to all Builder's Exchanges and Plan Rooms on record as having bidding documents on file.

Bidders shall not rely on oral instructions or representations made to bidders by any officer, agent or employee of the Owner or A/E.

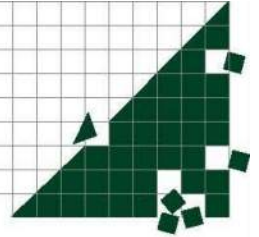

ADDENDUM

PROJECT:

**Bottineau Ridge III Apartments
Maple Grove, MN
Project No. 19027**

ADDENDA #1

Date: January 27th, 2021

**Please make the following changes to the plans previously issued January 12th, 2021.
Revisions noted with Letter “A” to the construction documents and project manual.**

Project Manual:

1. **Title:** Performance outline added to mechanical engineer
2. **Table of contents:**
 - a. Gas fireplace in lieu of electric
 - b. Trash chutes added to spec
 - c. Civil specs provided
3. **Alternates:**
 - a. Bike rack model provided in alt #2.
 - b. Fence and gate information provided in #3.
 - c. Alternate #7 deleted. Separate utilities to be required in base bid.
 - d. Exhibit provided for Alt. #9
 - e. Alt. #10 and #11 provided.
4. **Intended Methods Worksheet:** Item 5.1b modified to note for heated garage to match mech spec.
5. **Universal Design Worksheet:** High contrast finishes to be provided throughout project.
6. **012300 Alternates:** Refer to page 17 for updated alternates.
7. **017419 Waste Management Plan:** 50% of construction waste must be recycled.
8. **061000 Rough Carpentry:** 15/32” okay for roof sheathing
9. **071500 Caulking:** All caulking must have zero or low-VOC contents.
10. **074000 Siding:** Vinyl siding in lieu of steel.
11. **081400 Interior Wood Doors:** Lynden doors is acceptable for door MFR.
12. **083600 Overhead Doors:**
 - a. R-13min. insulated door in lieu of R-7.
 - b. Loop in concrete to exit and operators to enter.
 - c. 3” wide track system – “commercial grade track system”
13. **085300 Vinyl Windows:** MHFA requirements noted in spec. Energy star, blinds, screens, window fall protection all required.
14. **087000 Finish Hardware:** Falcon okay for closer MFR.
15. **090000 Interior and Exterior finishes:**
 - a. Al’s Ornamental iron and welding acceptable MFR.
 - b. Notes omitted in Div. 6. Refer to the applicable spec section.
 - c. RF – Rubber Flooring: Raised round for landing surfaces and grit tape inserts for treads. See product info attached in spec.

- d. FM – Floor Mat: Reese Perfec Mat Aluminum Hinge. Product Info provided in spec.
 - e. Interior signage color selections provided.
 - f. Appliance list provided from Phase II.
16. **092500 Gypsum Board:** Tubs and showers to provide moisture-resistant gypsum board above fiberglass enclosure.
17. **096500 Resilient Flooring:** All hard surfaces must meet science certification systems floorscore per EGCC 6.7a.
18. **103100 Gas Fireplace:** Not electric
19. **105513 Mailboxes:** Updated MFR and style.
20. **108000 Bath/Toilet Accessories:** Stainless steel finish in lieu of white for grab bars
- 21. 109900 Misc. Specialties:**
- a. No flagpole
 - b. Electrician to provide camera system. See elect. specs.
 - c. Part 2 – B: Section omitted.
 - d. Part 2 – C: Charcoal grill in lieu of gas. Location TBD.

Construction Documents:

Sheet A101A –First Floor Plan Area “A”

- 22. Flooring change locations provided in corridor, lobby stair, elevator lobby and vestibule.
- 23. Number notes 85 & 86 revised to note for plastic laminate countertops in community kitchen.
- 24. Finish schedule adjusted in Lobby 002 & Elev. Lobby 012.
- 25. Architectural pier columns provided at flooring change by elevator lobby.

Sheet A102A –Second Floor Plan Area “A”

- 26. Flooring change locations provided in corridor, lobby stair, and elevator lobby.
- 27. Architectural pier columns provided at flooring change by elevator lobby.
- 28. Finish schedule adjusted at elevator lobby 025.

Sheet A201-204 –Unit Floor Plans

- 29. Number notes adjusted for linen and closet shelving to match 57-61 on A602.
- 30. Countertop finish provided for vanities, movable island and kitchen.
- 31.

Sheet A401 –Door & Window Schedules

- 32. Interior common doors to be AL Series and dwelling unit doors to be F Series.

Sheet A501-502 –Exterior Elevations

- 33. Chieseld stone cap shown at window sill locations within the face brick façade

Sheet A602 –Interior Elevations

- 34. Elevations 35-36 adjusted to show ceramic tile height.

Sheet A701 –Typical Cross Section

35. Notes for low-VOC caulking to be provided at all wall, floor and joint penetrations to prevent pest entry per MHFA requirements.

Sheet A801 –Typical Details

36. Details 11, 13 & 14 adjusted to show trim by siding MFR in lieu of 1x prefinished trim.

Sheet A803 –Typical Underground Details

37. Details 35 & 44 adjusted to show 2” of insulation in lieu of 3”.

38. Concrete patio to be stamped as well.

Sheet A901 –UL Wall Details

39. Detail 26 with gypsum sheathing is the alternate now. Typical condition will have wood structural panels for the exterior wall per the spec.

END OF ADDENDA



David Majchrzak, MN Reg. # 56381

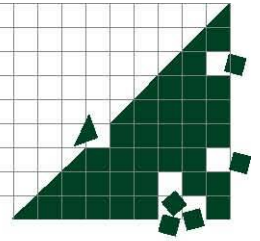

Proposal Request

PROJECT:

**Bottineau Ridge Apartments III
Maple Grove, MN
Project No. 19027**

Proposal Request #1

Date: Feb. 22nd, 2021

See below for a general itemized list of changes from the “Bid Set” to the “Permit Set”. The General Contractor is responsible for verifying all aspects of the bids with the final permit set.

Architectural Plans:

Sheets A001 – Title Sheet:

1. Drawing Log Updated.

Sheets A100 – Overall Basement and First Floor Plan:

2. 16” CIP wall adjust to show rock face block veneer to match elevations.

Sheets A100A-B – Enlarged Basement Plans – Areas “A” & “B”:

3. “C” Wall Types revised to show reinforcement as required by structural.
4. See revised number notes.
5. Floor drain provided by recycling area.
6. 2 hour fire wall by recycling to remain as the existing wall in lieu of constructing a new wall.
7. Bike storage provide at each stall per approved alternate #2.
8. Gate and fence provided by electrical space per approved alternate #3.
9. Wall types at the Refuse room and the Mechanical space revised to CIP walls in lieu of CMU to match structural shearwall requirements.
10. Wall types at Storage room revised to CIP to match structural bearing requirements.

Sheets A101A-B – Enlarged First Floor Plans – Areas “A” & “B”:

11. Wall type 2 provided in plan set.
12. See revised number notes.
13. TV and/or mechanical equipment provided in Club Room, Vestibule and Elevator Lobby.
14. Accessible push button provided at each door on each side in the Vestibule.
15. Dimensions adjusted at 16” foundation/rock face block veneer wall on NW side to match detail 44/A803.
16. Walls adjusted at Refuse room to match walls above and structural.

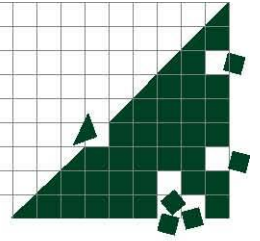

Sheets A102A-B – Enlarged Second Floor Plans – Areas “A” & “B”:

17. See revised number notes.
18. Location for TV provided in Fitness room.
19. Section markers were provided at the lobby stair.
20. Dimensions adjusted at 16” foundation/rock face block veneer wall on NW side to match detail 44/A803.

Sheets A103A-B – Enlarged Third Floor Plans – Areas “A” & “B”:

21. Dimensions adjusted at 16” foundation/rock face block veneer wall on NW side to match detail 44/A803.
22. See revised number notes.

Sheets A105 – Roof Plan:

23. Note for ridge vent to include snow filter.

Sheets A110 – First and Second Floor Reflected Ceiling Plan

24. Ceiling feature at second story ceiling provided per approved alternate #10. See detail 3/A110.

Sheets A201-204 – Unit Plans

General Notes:

25. See revised number notes.
26. Linen closets in bathrooms were revised to show face frame cabinets to match the number note and pictures from Phase II.
27. Side by side washers were revised to note for floor drain to be included in disaster pan per MHFA specs.
28. Ceiling fans provided in each living room.
29. Robe hooks were moved from the linen closet to a wall location.
30. Curtain rod at tubs adjusted to show curved rod to match Phase II.

Specific Units:

31. Unit 4A: Hallway adjusted to maintain 42” clear per UD requirements.

Sheets A401 – Door and Window Schedule

32. B006: Hardware adjusted
33. 001A&B: Transom added to notes
34. 010B & 015A: Door frame adjusted to alum. st. fr.
35. Bedrooms unit doors adjusted to not have locking hardware
36. Door hardware 26 adjusted to include astragal

Sheets A501-502 – Exterior Elevations

37. Note for lighting in all entry canopies to match Phase II.

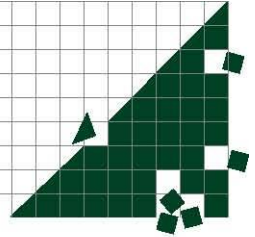

Sheets A601-602 – Interior Elevations

- 38. Cabinet above fridge adjusted to match Phase II.
- 39. Detail 12: Upper cabinets adjusted.
- 40. Detail 16: Base cabinet adjusted to include removable cabinet front.
- 41. Details 30-32: Elevation adjusted to show half high linens to match Phase II.
- 42. Detail 35: Elevation adjusted to show wall mounted vanity and soap dispenser on the right.

Sheets A701-703 – Cross Sections

- 43. Note for ridge vent to include snow filter.
- 44. R-21 spray foam insulation provided in lieu of batt insulation per approved alternate #4.
- 45. ACT's provided in elevator section to match RCP's.
- 46. Elevator shaft walls adjusted to note for CIP to match plan.
- 47. Detail 10A adjusted to match Phase II.
- 48. Stair landing framing adjusted to 2x10's to match structural.

Sheets A801 – Typical Detail Sheet 1:

- 49. Details 11B, 12A, 12B, 14A provided in final set.
- 50. Details 11A, 13, & 14A revised to show spray foam in lieu batt insulation per approved alternate #4.
- 51. Detail 7 adjust to show flexible stair nosing to match spec.
- 52. Details 17A-B adjusted to show face brick veneer to match Phase II.

Sheet A802 – Typical Detail Sheet 2:

- 53. Detail 30 adjusted to show face brick veneer to match Phase II.
- 54. Detail 34 revised to match RCP's,

Sheet A803 – Typical Underground Garage Details:

- 55. Details 35, 38 & 41 provided in final plan set.
- 56. Detail 43 adjusted to match what was done in the field for Phase II with typical grade 6" lower than FF.
- 57. Detail 37 adjusted to show face brick and CIP to match structural.
- 58. Detail 47 adjusted to call out flexible stair nosing to match the spec.

Architectural Specifications:

004100 – Bid Form:

- 59. Alternate schedule updated with approvals from ownership.
- 60. Corner guard section provided to match notes from architectural plans. See section 102600.
- 61. See the revised Universal Design worksheet for the 8 optional items selected.

COLE GROUP

A R C H I T E C T S

216 Park Avenue S. • Suite 102
St. Cloud, MN 56301
320-654-6570 • Fax 230-6570

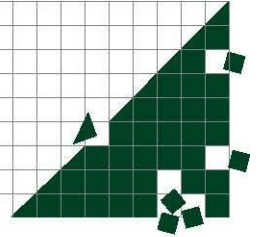

Structural:

See comments from structural under separate cover.

Civil:

Sheet C8-1 – Civil Details:

62. Detail 2031 adjusted to show geotextile filter fabric below Class 5 per approved Alternate #5.

END OF PROPOSAL REQUEST

David Majchrzak, MN Reg. #56381

S:\Project Files\Apart19\19027 - Bottineau Ridge Ph. III - Maple Grove, MN - Duffy Development\Construction Administration\Proposal Requests\PR#1\Bottineau Ridge III Apartments - Work Change Proposal Request #1.docx



Project: Bottineau Ridge Phase III

Permit Revision Narrative:

S001 Structural Notes

- Update Design Criteria Notes and Modified Precast/Prestressed Concrete Notes

S101 Foundation Plan

- Added existing building w/ correlating details
- Updated misc dimensions
- Removed Housekeeping pads
- Updated stepped footing locations

S201 1st Floor Framing Plan

- Updated stair framing and details.
- Updated misc wall thicknesses at garage entry.
- Added existing building w/ correlating details
- Added keynote #17 and locations.

S202 2nd Floor Framing Plan

- Updated stair framing and details.
- Updated Refuse room framing w/ additional keynotes

S203 3rd Floor Framing Plan

- Updated stair framing and details.

S204 4th Floor Framing Plan

- Updated stair framing and details.

S205 Roof Framing Plan

- Updated Refuse room framing

S301 Framing Details

- Updated detail 9/S301 to show pier options
- Added existing fdn tie in details at 11/S301

S401 Framing Details

- Updated detail 12/S401
- Updated detail 15/S401
- Updated detail 16/S401
- Updated detail 17/S401

S402 Framing Details

- Updated detail 10/S402

S403 Framing Details

- Updated detail 1/S403

S404 Framing Details

- Updated detail 5/S404
- Updated detail 6/S404
- Updated detail 3/S404

Thank you,

A handwritten signature in blue ink, appearing to read "Lincoln Regula". The signature is fluid and cursive, with the first name being more prominent than the last.

Lincoln Regula
Project Engineer

SUMMARY OF WORK**1. PART 1 GENERAL****A. SECTION INCLUDES**

- 1.1. Contractor use of site.
- 1.2. Work Sequence.
- 1.3. Abbreviated written summary.

1.1 CONTRACTOR USE OF SITE

- A. Access to Site: As indicated on site plan or agreed to in writing by Architect/Engineer.
- B. Construction Operation Limits: Limited to owner's property and areas noted on Drawings.

1.2 WORK SEQUENCE

- A. Construct Work to accommodate Owner's occupancy requirements during and after the construction period, coordinate construction schedule and operations with owner.
Cooperate and schedule as required for work performed by owner.

1.3 ABBREVIATED WRITTEN SUMMARY

- A. Briefly and without effect upon the contract documents, the work of the contract can be summarized as follows:

The Work includes construction of One (1), four-story, 50-Unit Apartment, referred to by name as Bottineau Ridge III, on site as shown.

Work to be done by contractors and suppliers: excavation, backfill, concrete foundation, concrete slab, masonry and wood framed exterior wall, wood roof trusses, wood stud interior partitions, asphalt roof system, wall insulation, metal doors and frames, finish door hardware, entry system, gypsum board interior walls and finishes, sealants, painting, mechanical and electrical installations, elevator, and site work.

Green communities check list requirements, energy star 3.0 check list.

Work by Owner includes some and/or all of the following: Building Security System, Furniture, etc.

Coordinate extent and timing of this work with the G.C./Owner.

PART 1 GENERAL**1.1 SECTION INCLUDES**

- A. Procedural requirements for proposed substitutions.
- B. Products and installation for patching and extending Work
- C. Transition and adjustments.
- D. Repair of damaged surfaces, finishes, and cleaning.

1.2 RELATED SECTIONS

- A. Section 01 31 13 – Project Coordination.
- B. Section 01 31 19 – Project Meetings.
- C. Section 01 50 00 - Construction Facilities and Temporary Controls.
- D. Section 01 73 29 - Cutting and Patching.

1.3 SUBSTITUTION PROCEDURES DURING BIDDING PHASE

- A. Section 00 2600 - Procurement Substitution Procedures specifies time restrictions for submitting requests for substitutions during the bidding period, and the documents required.

1.4 SUBSTITUTION PROCEDURES AFTER BIDDING PHASE

- A. Submittal Form (after contract award):
 - 1. Submit substitution requests by completing the form.
- B. Architect will consider requests for substitutions only within 30 days after date of Agreement. Requests for substitutions after the bids have been received are done so at the risk of the Contractor. Substitutions may not be granted.
- C. Substitutions may be considered when a product becomes unavailable through no fault of the Contractor.
- D. Substitutions will not be considered under one or more of the following circumstances:
 - 1. When they are indicated or implied on shop drawing or product data submittals, without having received prior approval.
 - 2. Without a separate written request.
 - 3. When acceptance will require revisions to the Contract Documents.

1.5 RESOLUTION

- A. Architect may request additional information and documentation prior to rendering a decision. Provide this data in an expeditious manner.
- B. Architect will notify Contractor in writing of decision to accept or reject request.

1.6 ACCEPTANCE

- A. Accepted substitutions change the work of the Project. They will be documented and incorporated into work of the project by Change Order, Construction Change Directive, Architectural Supplementary Instructions, or similar instruments provided for in the Conditions of the Contract.

PART 2 PRODUCTS**2.1 PRODUCTS FOR PATCHING AND EXTENDING WORK**

- A. New Materials: As specified in product Sections; match existing Products and work for patching and extending work.
- B. Type and Quality of Existing Products: By inspection and testing Products where necessary, referring to existing Work as a standard.

PART 3 EXECUTION**3.1 EXAMINATION**

- A. Verify that areas are ready for installation of new Work.
- B. A Substitution Request for products, assemblies, materials, and equipment constitutes a representation that the submitter:
 - 1. Has investigated proposed product and determined that it meets or exceeds the quality level of the specified product, equipment, assembly, or system.
 - 2. Agrees to provide the same warranty for the substitution as for the specified product.
 - 3. Agrees to provide same or equivalent maintenance service and source of replacement parts, as applicable.
 - 4. Agrees to coordinate installation and make changes to other work that may be required for the work to be complete, with no additional cost to Owner.
 - 5. Waives claims for additional costs or time extension that may subsequently become apparent.
 - 6. Agrees to reimburse Owner and Architect for review or redesign services associated with re-approval by authorities.

C. Document each request with complete data substantiating compliance of proposed substitution with Contract Documents. Burden of proof is on proposer.

D. Content: Include information necessary for tracking the status of each Substitution Request, and information necessary to provide an actionable response.

1. Forms included in the Project Manual are adequate for this purpose, and must be used.

E. Limit each request to a single proposed substitution item.

1. Submit an electronic document, combining the request form with supporting data into single document.

3.2 PREPARATION

A. Prepare surface and remove surface finishes to provide for proper installation of new work and finishes.

B. Close openings in exterior surfaces to protect existing work and salvage items from weather and extremes of temperature and humidity. Insulate ductwork and piping to prevent condensation in exposed areas.

3.3 INSTALLATION

A. Coordinate work of alternations to expedite completion.

B. Finish visible surfaces to specified condition for each material, with a neat transition to adjacent finishes.

C. Install Products as specified in individual Sections.

3.4 FINISHES

A. Finish surfaces as specified in individual Product Sections.

B. Finish patches to product uniform finish and texture over entire area.

PART 1 GENERAL**1.1 SECTION INCLUDES**

- A. Cash and material allowances.
- B. Payment and modification procedures relating to allowances.

1.2 RELATED REQUIREMENTS

- A. Section 01 2000 - Price and Payment Procedures: Additional payment and modification procedures.

1.3 CASH AND MATERIAL ALLOWANCES

- A. Costs Included in Allowances: Cost of product to Contractor or subcontractor, less applicable trade discounts.
- B. Architect Responsibilities:
 - 1. Consult with Contractor for consideration and selection of products, suppliers, and installers.
 - 2. Select products in consultation with Owner and transmit decision to Contractor.
 - 3. Prepare Change Order.
- C. Contractor Responsibilities:
 - 1. Assist Architect in selection of products, suppliers, and installers.
 - 2. Obtain proposals from suppliers and installers and offer recommendations.
 - 3. On notification of which products have been selected, execute purchase agreement with designated supplier and installer.
 - 4. Arrange for and process shop drawings, product data, and samples. Arrange for delivery.
 - 5. Promptly inspect products upon delivery for completeness, damage, and defects. Submit claims for transportation damage.
- D. Differences in costs will be adjusted by Change Order.

1.4 ALLOWANCES SCHEDULE: Coordinate with MHFA Green Communities Criteria.

- A. Playground Equipment: Provide a \$25,000.00 allowance** for furnishing and installation of playground equipment.
- B. Playground Surfacing: Provide a \$25,000.00 allowance** for furnishing and installation of playground surfacing.
- C. Lobby Mural: Provide a \$4,000 allowance** for large mural in lobby; verify design specs with owner.

PART 2 PRODUCTS - NOT USED**PART 3 EXECUTION - NOT USED**

PART 1 GENERAL**1.1 DESCRIPTION**

- A. This Section describes the limits of the requested alternates to the Contract work. Refer to the Product/Execution Articles of the appropriate Specifications and the Drawings for information pertaining to the work of each alternate.
- B. Each proposal under an alternate shall include all incidental work and all adjustments necessary to accommodate the changes. All work shall meet the requirements of the Drawings, Specifications and appropriate details.
- C. Submit each alternate proposal as an individual cost for the particular alternate and shall be proposed under the premise that no other alternates have been accepted. Should the work of an alternate called for by the Bid Form not affect the cost of the work, state "No Change" in the space provided. If an alternate is left blank, the Owner reserves the right to throw out the entire bid or interpret the alternate as "No Change".
- D. Include taxes which are applicable to work involved in alternates as well as costs, if any, for increased coverage of bonds and insurance.
- E. Any of the alternates may be accepted by Owner and will be used in determining the low bidder.
- F. Owner may, at his option, vary the scope of the work by authorizing alternates which will add to the work, deduct from the work or substitute materials, equipment or methods.
- G. Each Bidder shall examine the Drawings and Specifications to determine the extent to which his work is affected by bid alternates. Include in the space provided on the bid form the cost of any added or deducted work resulting from each alternate.
- H. Contractor is responsible for providing work if applicable to each alternate, whether or not an added or deducted cost is included on his bid form.

PART 2 PRODUCTS**2.1 IMPLEMENTATION**

- A. If the Owner elects to proceed on the basis of one or more of the alternates, make all modifications to the Work required in the furnishing and installation of the selected alternate or alternates subject to the approval of the Architect at no additional cost to the Owner except as proposed in the Bid.
- B. Coordinate pertinent related work and modify surrounding work as required to properly integrate the work under each alternate, and to provide the complete construction required by Contract Documents.
- C. If so stated in the Agreement or modifications thereto, provide alternate materials, equipment and/or construction as specified.

2.2 ALTERNATES SCHEDULE: 9 Alternates

Refer to Page 17 for Alternates

PART 1: GENERAL**1.1 SECTIONS INCLUDES**

- A. Schedule of Values
- B. Application for Payment
- C. Change procedures
- D. Alternates

1.2 RELATED SECTIONS

- A. Section 01 33 00 - Submittals: Schedule of Values.
- B. Section 01 60 00 - Material and Equipment: Product substitutions and alternates.

1.3 SCHEDULE OF VALUES

- A. Submit typed schedule on AIA Form G703 - Application and Certificate for Payment Continuation Sheet.
- B. G.C. to submit Schedule of Values in duplicate within 15 days after date established in Notice to Proceed.
 - 1. Framing, Insulation, Gypsum Board, Electrical, Mechanical values by rough-in and finish and also by floor.
- C. Format: Utilize the Table of Contents of this Project Manual. Identify each line item with number and title of the major specification Section. Identify site mobilization bonds and insurance.
- D. Revise schedule to list approved Change Orders, with each Application for Payment.

1.4 APPLICATIONS FOR PAYMENT

- A. Submit three copies of each application on AIA G702/G703 - Application for Payment.
- B. Content and Format: Utilize Schedule of Values for listing items in Application for Payment.
- C. Payment Period: Monthly. Contractor shall verify with architect and owner day of month to submit.
- D. Waiver of suppliers and subcontractor.

1.5 CHANGE PROCEDURES

- A. The Architect/Engineer will advise of minor changes in the Work not involving an adjustment to Contract Sum/Price or Contract Time as authorized by AIA A201, current edition.
- B. The Architect/Engineer may issue a Proposal Request which includes a detailed description of a proposed change with supplementary or revised Drawings and specifications, a change in Contract Time for executing the change with a stipulation of any overtime work required. Contractor will prepare and submit an estimate with 10 days.
- C. The Contractor may propose a change by submitting request for change to the Architect/Engineer, describing the proposed change and its full effect on the Work. Include a statement describing the reason for the change, and the effect on the Contract Sum/Price and Contract Time with full documentation and a statement describing the effect on Work by separate or other contractors. Document any requested substitutions in accordance with Section 01 60 00.
- D. Stipulated Sum/Price Change Order: Based on Proposal Request and Contractor's fixed maximum price quotation.
- E. Change Order Forms: AIA G701 Change Order.
- F. Execution of Change Orders: Architect/Engineer will issue Change Orders for signatures of parties as provided in the Conditions of the Contract.

1.6 ALTERNATES

- A. As indicated on Bid Form (00 41 00).
- B. Each proposal under an alternate shall include all incidental work and all adjustments necessary to accommodate the changes. All work shall meet the requirements of the Drawings, Specifications and appropriate details.
- C. Each alternate proposal shall be submitted as an individual cost for the particular alternate and shall be proposed under the premise that no other alternates have been accepted. Should the work of an alternate called for by the Bid Form not affect the cost of the work, "No Change" shall be stated.
- D. Any of the alternates may be accepted by Owner and will be used in determining the low bidder.
- E. Owner may, at his option, vary the scope of the work by authorizing alternates which will add to the work, deduct from the work or substitute materials, equipment or methods.
- F. Notification: Immediately following Award of Contract, prepare and distribute to each party involved, notification of the status of each alternate. Indicate whether alternates have been accepted, rejected, or deferred for consideration at a later date. Include a complete description of negotiated modifications to alternates, if any.

PART 2 PRODUCTS

- 1. Not Used

PART 3 EXECUTION

- 1. Not Used

PART 1: GENERAL**1.1 DESCRIPTION**

A. Comply with procedures described in this Section when applying for progress payment and final payment under the Contract. Submit on form AIA G702/703, Application and Certificate For Payment.

1.2 SUBMITTALS

A. Based upon Applications for Payment submitted to the Architect by the Contractor and Certificates of Payment issued by the Architect, the Owner shall make progress payments on account of the Contract Sum to the Contractor as provided below and elsewhere in the Contract Documents.

B. The period covered by each application for Payment shall be one calendar month ending on the last day of the month.

C. Provided an Application for Payment is received by the Architect not later than the first (1st) day of a month the Owner shall make payment to the Contractor not later than the thirtieth (30th) day of the same month. If an Application for Payment is received by the Architect after the application date fixed above, payment shall be made by the Owner in the following monthly cycle.

D. Each Application for Payment shall be based upon the Schedule of Values submitted in accordance with the Contract Documents. The Schedule of Values shall allocate the entire Contract Sum among the various portions of the Work and be prepared in such form and supported by such data to substantiate its accuracy as the Architect may require. This Schedule, unless objected to by the Architect, shall be used as a basis for reviewing the Applications for Payment.

E. The Applications for Payment shall indicate the percentage of completion of each portion of the Work as of the end of the period covered by the application for Payment.

F. Subject to the provisions of the Contract Documents, the amount of each progress payment shall be computed as follows:

1. Take that portion of the Contract Sum properly allocatable to completed Work as determined by multiplying the percentage completion of each portion of the Work in the Schedule of Values, less retainage of ten percent (10%). Pending final determination of cost to the Owner of changes in the Work, amounts not in dispute may be included as provided in Subparagraph 7.37 of the General Conditions even though the Contract Sum has not yet been adjusted by Change Order.
2. Add that portion of the Contract Sum properly allocatable to materials and equipment delivered and suitably stored at the site for subsequent incorporation in the completed construction (or, if approved in advance by the Owner, suitably stored off the site at a location agreed upon in writing).
3. Subtract the aggregate of previous payments made by the Owner.
4. Subtract amounts, if any, for which the Architect has withheld or nullified a Certificate for Payment as provided in Paragraph 9.5 of the General Conditions

G. The progress payment amount determined in accordance with Paragraph 5.6 shall be further modified under the following circumstances:

1. Add, upon Substantial Completion of the Work, a sum sufficient to increase the total payments to ninety-five percent (95%) of the Contract Sum, less such amounts as the Architect shall determine for incomplete Work and unsettled claims.
2. Add, if final completion of the Work is thereafter materially delayed through no fault of the Contractor, any additional amounts payable in accordance with Subparagraph 9.10.3 of the General Conditions.

PART 1: GENERAL**1.1 SECTION INCLUDES**

- A. Project coordination administrator.
- B. Construction mobilization.
- C. Schedules.
- D. Submittals.
- E. Coordination drawings.
- F. Closeout procedures.

1.2 RELATED SECTIONS

- A. Section 00 72 00 - General Conditions
- B. Section 01 11 00 - Summary of Work: Work sequence.
- C. Section 01 31 19 - Coordination and Meetings: Project meetings, Preconstruction conferences, Progress meetings.
- D. Section 01 70 00 – Execution and Closeout Requirements.

1.3 CONSTRUCTION MOBILIZATION

- A. Cooperate with the Administrator in allocation of mobilization areas of site; for field offices and sheds, for contractors access, traffic, and parking facilities.
- B. During construction, coordinate use of site and facilities through the A/E.
- C. Comply with A/E procedures for intra-project communications; submittals, reports and records, schedules, coordination drawings, and recommendations; and resolution of ambiguities and conflicts.
- D. Comply with instructions of the A/E for use of temporary utilities and construction facilities.
- E. Coordinate field engineering and layout work under instructions of the A/E.

1.4 SCHEDULES

- A. Submit preliminary progress schedule in accordance with Section 01 33 00 coordinated with Project construction schedule.
- B. After review, revise and resubmit schedule to comply with revised Project schedule.
- C. During progress of Work, revise and resubmit as directed.

1.5 SUBMITTALS

- A. Provide submittals to A/E for review.
- B. Submit applications for payment as indicated.
- C. Submit requests for interpretation of Contract Documents, and obtain instructions through A/E.
- D. Process requests for substitutions, and change orders, through A/E.
- E. Deliver closeout submittals for review and preliminary inspection reports, for transmittal to Architect/Engineer.

1.6 COORDINATION DRAWINGS

- A. Provide information required by A/E for preparation of coordination drawings.
- B. Review drawings prior to submission to Architect/Engineer.

1.7 CLOSEOUT PROCEDURES

- A. Notify A/E when Work is considered ready for Substantial Completion.
- B. Comply with A/E's instructions to correct items of Work listed in executed Certificates of Substantial Completion.
- C. Notify A/E when Work is considered finally complete.
- D. Comply with A/E's instructions for completion of items of Work determined by the Architect/Engineer's final inspection.

PART 2 PRODUCTS

- A. Not Used

PART 3 EXECUTION

- A. Not Used

PART 1: GENERAL**1.1 SECTION INCLUDES**

- A. Coordination.
- B. Field engineering.
- C. Preconstruction conference.
- D. Progress meetings.

1.2 RELATED SECTIONS

- A. Section 01 31 13 - Project Coordination

1.3 COORDINATION

- A. Coordinate scheduling, submittals, and Work of the various Sections of specifications to assure efficient and orderly sequence of installation of interdependent construction elements.
- B. Verify that utility requirement characteristics of operating equipment are compatible with building utilities. Coordinate work of various Sections having interdependent responsibilities for installing, connecting to, and placing in service, such equipment.
- C. Coordinate space requirements and installation of mechanical and electrical work which are indicated diagrammatically on Drawings. Follow routing shown for pipes, ducts, and conduit, as closely as practicable; place runs parallel with line of building. Utilize spaces efficiently to maximize accessibility for other installations, for maintenance, and for repairs.
- D. In finished areas except as otherwise indicated, conceal pipes, ducts, and wiring within the construction. Coordinate locations of fixtures and outlets with finish elements.
- E. Coordinate completion and clean up of Work of separate Sections in preparation for Substantial Completion.
- F. After Owner occupancy of premises, coordinate access to site for correction of defective Work and Work not in accordance with Contract Documents, to minimize disruption of Owner's activities.

1.4 FIELD ENGINEERING

- A. Contractor to locate and protect survey control and reference points.
- B. Control datum for survey is that established by A/E provided survey shown on Drawings.
- C. Provide field engineering services. Establish elevations, lines, and levels, utilizing recognized engineering survey practices.

1.5 PRECONSTRUCTION CONFERENCE

- A. Architect will schedule a conference after Notice of Award.
- B. Attendance Required: Owner, Contractor, Architect/Engineer, Prime Contractors.
- C. Agenda:
 - (1) Execution of Owner-Contractor Agreement.
 - (2) Submission of executed bonds and insurance certificates.
 - (3) Distribution of Contract Documents.
 - (4) Submission of list of Subcontractors, list of products, Schedule of Values, and progress schedule.
 - (5) Designation of personnel representing the parties in Contract, and the Architect/Engineer.
 - (6) Procedures and processing of field decisions, submittals, substitutions, applications for payments, proposal request, Change Orders and Contract closeout procedures.
 - (7) Scheduling.
- D. Progress Meetings by G.C.
- E. Schedule and administer meetings throughout progress of the Work.
- F. Make arrangements for meetings, prepare agenda with copies for participants, preside at meetings, record minutes, and distribute copies within two days to Contractors, Owner, Architect/Engineer, participants, and those affected by decisions made.
- G. Attendance Required: Job superintendent, major Subcontractors and suppliers, Owner, Architect/Engineer, as appropriate to agenda topics for each meeting.
- H. Agenda:
 - (1) Review minutes of previous meetings.
 - (2) Review of Work progress.
 - (3) Field observations, problems, and decisions.
 - (4) Identification of problems which impede planned progress.
 - (5) Review of submittals schedule and status of submittals.
 - (6) Review of off-site fabrication and delivery schedules.
 - (7) Maintenance of progress schedule.
 - (8) Corrective measures to regain projected schedules.
 - (9) Planned progress during succeeding work period.
 - (10) Coordination of projected progress.
 - (11) Maintenance of quality and work standards.
 - (12) Effect of proposed changes on progress schedule and coordination.
 - (13) Other business relating to Work.

PART 2 PRODUCTS Not Used

PART 3 EXECUTION Not Used

PART 1: GENERAL**1.1 SECTION INCLUDES**

- A. Submittal procedures.
- B. Shop drawings.
- C. Product data.
- D. Samples.
- E. Manufacturers' instructions.
- F. Manufacturers' certificates.

1.2 RELATED SECTIONS

- A. Section 01 29 73 - Contract Considerations: Schedule of Values.
- B. Section 01 45 16 - Quality Control: Manufacturers' field services and reports.
- C. Section 01 77 00 – Project Closeout: Contract warranty and manufacturer's certificates closeout submittals.

1.3 SUBMITTAL PROCEDURES

- A. Transmit each submittal with AIA Form G810 (or approved equal).
- B. Sequentially number the transmittal forms. Re-submittals to have original number with an alphabetic suffix.
- C. Identify Project, Contractor, Subcontractor or supplier; pertinent Drawing sheet and detail number(s), and specification Section number, as appropriate.
- D. Apply Contractor's stamp, signed or initialed certifying that review, verification of Products required, field dimensions, adjacent construction Work, and coordination of information, is in accordance with the requirements of the Work and Contract Documents.
- E. Schedule submittals to expedite the Project, and deliver to Architect/Engineer at business address.
Coordinate submission of related items.
- F. Identify variations from Contract Documents and Product or system limitations which may be detrimental to successful performance of the completed Work.
- G. Provide space for Contractor and Architect/Engineer review stamps.
- H. Revise and resubmit submittals as required, identify all changes made since previous submittal.
- I. Distribute copies of reviewed submittals to concerned parties. Instruct parties to promptly report any inability to comply.

1.4 SHOP DRAWINGS

- A. Submit 4 copies.
- B. After review and distribute in accordance with Article on Procedures above and for Record Documents described in Section 01 77 00 - Project Closeout.

1.5 PRODUCT DATA

- A. Submit 4 copies.
- B. Mark each copy to identify applicable products, models, options, and other data. Supplement manufacturers' standard data to provide information unique to this Project.
- C. After review, distribute in accordance with Article on Procedures above and provide copies for Record Documents described in

1.6 SAMPLES

- A. Submit samples to illustrate functional and aesthetic characteristics of the Product, with integral parts and attachment devices. Coordinate sample submittals for interfacing work.
- B. Submit samples of finishes from the full range of manufacturers' standard colors, textures, and patterns for Architect/Engineer's/Interior Designer's selection.
- C. Include identification on each sample, with full Project information.
- D. Submit the number or samples specified in individual specification Sections; one of which will be retained by Architect/Engineer.
- E. Reviewed samples which may be used in the Work are indicated in individual specification Sections.

1.7 MANUFACTURER'S INSTRUCTIONS

- A. When specified in individual specification Sections, submit manufacturers' printed instructions for delivery, storage, assembly, installation, start-up, adjusting, and finishing, in quantities specified for Product Data.
- B. Identify conflicts between manufacturers' instructions and Contract Documents.

1.8 MANUFACTURER'S CERTIFICATES

- A. When specified in individual specification Sections, submit manufacturers' certificate to Architect/Engineer for review, in quantities specified for Product Data.
- B. Indicate material or product conforms to or exceeds specified requirements. Submit supporting reference date, affidavits, and certifications as appropriate.
- C. Certificates may be recent or previous test results on material or Product, but must be acceptable to Architect/Engineer.

PART 1: GENERAL**1.1 SECTION INCLUDES**

- A. Quality assurance.
- B. Schedule of references.

1.2 RELATED SECTIONS

- A. Document A201 - General Conditions: Reference Standards.

1.3 QUALITY ASSURANCE

- A. For products or workmanship specified by association, trade, or Federal Standards, comply with requirements of the standard, except when more rigid requirements are specified or are required by applicable codes.
- B. Conform to reference standard by date of issue current on date of Contract Documents.
- C. Obtain copies of standards when required by Contract Documents.
- D. Maintain copy at jobsite during submittals, planning, and progress of the specific work, until Substantial Completion.
- E. Should specified reference standards conflict with Contract Documents, request clarification from Architect/Engineer before proceeding.
- F. The contractual relationship of the parties to the Contract shall not be altered from the Contract Documents by mention or inference otherwise in any reference document.

1.4 SCHEDULE OF REFERENCES

AA	Aluminum Association 818 Connecticut Avenue, N.W. Washington, DC 20006
AABC	Associated Air Balance Council 1000 Vermont Avenue, N.W. Washington, DC 20005
AASHTO	American Association of State Highway and Transportation Officials 444 North Capitol Street, N.W. Washington, DC 20001
ACI	American Concrete Institute Box 19150 Redford Station Detroit, MI 48219
ADC	Air Diffusion Council 230 North Michigan Avenue Chicago, IL 60601
ADA	Accessibility Guidelines Published by ATBCB Federal Register Vol. 56, No. 144/July 26, 1991
AGC	Associated General Contractors of America 1957 E Street, N.W. Washington, DC 20006
AI	Asphalt Institute Asphalt Institute Building College Park, MD 20740
AIA	American Institute of Architects 1735 New York Avenue, N.W. Washington, DC 20006
AISC	American Institute of Steel Construction 400 North Michigan Avenue Eighth Floor Chicago, IL 60611
AISI	American Iron and Steel Institute 1000 16th Street, N.W. Washington, DC 20036
AITC	American Institute of Timber Construction 333 W. Hampden Avenue Englewood, CO 80110

014219 - REFERENCE STANDARDS

AMCA	Air Movement and Control Association 30 West University Drive Arlington Heights, IL 60004
ANSI	American National Standards Institute 1430 Broadway New York, NY 10018
APA	American Plywood Association Box 11700 Tacoma, WA 98411
ARI	Air-Conditioning and Refrigeration Institute 1501 Wilson Boulevard Arlington, VA 22209
ASHRAE	American Society of Heating, Refrigerating and Air Conditioning Engineers 1791 Tullie Circle, N.E. Atlanta, GA 30329
ASME	American Society of Mechanical Engineers 345 East 47th Street New York, NY 10017
ASPA	American Sod Producers Association 4415 West Harrison Street Hillside, IL 60162
ASTM	American Society for Testing and Materials 1916 Race Street Philadelphia, PA 19103
AWI	Architectural Woodwork Institute 2310 South Walter Reed Drive Arlington, VA 22206
AWP	American Wood-Preservers' Association 7735 Old Georgetown Road Bethesda, MD 20014
AWS	American Welding Society 550 LeJeune Road, N.W. Miami, FL 33135
AWWA	American Water Works Association 6666 West Quincy Avenue Denver, CO 80235
BAAQMD	Bay Area Air Quality Management 939 Ellis Street San Francisco, CA 94109
BIA	Brick Institute of America 11490 Commerce Park Drive Reston, VA 22091
CRSI	Concrete Reinforcing Steel Institute 933 Plum Grove Road Schaumburg, IL 60195

DHI	Door and Hardware Institute 7711 Old Springhouse Road McLean, VA 22102
EJCDC	Engineers' Joint Contract Documents Committee American Consulting Engineers Council 1015 15th Street, N.W. Washington, DC 20005
EJMA	Expansion Joint Manufacturers Association 25 North Broadway Tarrytown, NY 10591
FGMA	Flat Glass Marketing Association 3310 Harrison White Lakes Professional Building Topeka, KS 66611
FM	Factory Mutual System 1151 Boston-Providence Turnpike P.O. Box 688 Norwood, MA 02062
FS	Federal Specification General Services Administration Specifications and Consumer Information Distribution Section (WFSIS) Washington Navy Yard, Bldg. 197 Washington, DC 20407
GA	Gypsum Association 1603 Orrington Avenue Evanston, IL 60201
ICBO	International Conference of Building Officials 5360 S. Workman Mill Road Whittier, CA 90601
IEEE	Institute of Electrical and Electronics Engineers 345 East 47th Street New York, NY 10017
IMIAC	International Masonry Industry All-Weather Council International Masonry Institute 815 15th Street, N.W. Washington, DC 20005
MBMA	Metal Building Manufacturer's Association 1230 Keith Building Cleveland, OH 44115
NAAMM	National Association of Architectural Metal Manufacturers 221 North LaSalle Street Chicago, IL 60601
NCMA	National Concrete Masonry Association P.O. Box 781 Herndon, VA 22070
NEMA	National Electrical Manufacturers' Association 2101 'L' Street, N.W. Washington, DC 20037
NFPA	National Fire Protection Association Battery March Park Quincy, MA 02269
NFPA	National Forest Products Association 1619 Massachusetts Avenue, N.W. Washington, DC 20036

NWMA	National Woodwork Manufacturers Association 205 W. Touhy Avenue Park Ridge, IL 60068
PCA	Portland Cement Association 5420 Old Orchard Road Skokie, IL 60077
PS	Product Standard U. S. Department of Commerce Washington, DC 20203
SDI	Steel Door Institute 712 Lakewood Center North Cleveland, OH 44107
SIGMA	Sealed Insulating Glass Manufacturers Association 111 East Wacker Drive Chicago, IL 60601
SMACNA	Sheet Metal and Air Conditioning Contractors' National Association 8224 Old Court House Road Vienna, VA 22180
TCA	Tile Council of America, Inc. Box 326 Princeton, NJ 08540
UL	Underwriters' Laboratories, Inc. 333 Pfingston Road Northbrook, IL 60062
WCLIB	West Coast Lumber Inspection Bureau 6980 S.W. Varns Road Box 23145 Portland, OR 97223
WWPA	Western Wood Products Association 1500 Yeon Building Portland, OR 97204

PART 1: GENERAL**1.1 SECTION INCLUDES**

- A. Quality assurance and control of installation.
- B. References.
- C. Field samples.
- D. Inspection and testing laboratory services.
- E. Manufacturers' field services and reports.

1.2 RELATED SECTIONS

- A. Section 01 42 19 - Reference Standards.
- B. Section 01 33 00 - Submittals: Submission of Manufacturers' Instructions and Certificates.
- C. Section 01 60 00 – Product Requirements: Requirements for material and product quality.

1.3 QUALITY ASSURANCE/CONTROL OF INSTALLATION

- A. Monitor quality control over suppliers, manufacturers, Products, services, site conditions, and workmanship, to produce Work of specified quality.
- B. Comply fully with manufacturers' instructions, including each step in sequence.
- C. Should manufacturers' instructions conflict with Contract Documents, request clarification before proceeding.
- D. Comply with specified standards as a minimum quality for the Work except when more stringent tolerances, codes, or specified requirements indicate higher standards or more precise workmanship.
- E. Perform work by persons qualified to produce workmanship of specified quality.
- F. Secure Products in place with positive anchorage devices designed and sized to withstand stresses, vibration, physical distortion or disfigurement.

1.4 REFERENCES

- A. Conform to reference standard by date of issue current on date of Contract Documents.
- B. Obtain copies of standards when required by Contract Documents.
- C. Should specified reference standards conflict with Contract Documents, request clarification from Architect/Engineer.
- D. The contractual relationship of the parties to the Contract shall not be altered from the Contract Documents by mention or inference otherwise in any reference document.

1.5 FIELD SAMPLES

- A. Install field samples at the site as required by individual specifications Sections for review.
- B. Acceptable samples represent a quality level for the Work.
- C. Where field sample is specified in individual Sections to be removed, clear area after field sample has been accepted by Architect/Engineer.

1.6 INSPECTION AND TESTING LABORATORY SERVICES

- A. Contractor to appoint, employ, and pay for services of an independent firm to perform inspection and testing.
- B. The independent firm will perform inspections, tests, and other services specified in individual specification Sections and as required by the Architect/Engineer.
- C. Reports will be submitted by the independent firm to the Architect/Engineer, in duplicate, indicating observations and results of tests and indicating compliance or non-compliance with Contract Documents.
- D. Cooperate with independent firm; furnish samples of materials, design mix, equipment, tools, storage and assistance as requested.
- E. Retesting required because of non-conformance to specified requirements shall be performed by the same independent firm on instructions by the Architect/Engineer. Payment for retesting will be charged to the Contractor by deducting inspection or testing charges from the Contract Sum/Price.

PART 1: GENERAL**1.1 INTENT AND CONDITIONS****A. Intent**

1. Define and coordinate structural testing and special inspection services.
2. Define and coordinate conventional testing and inspection services.
3. Provide a greater level of confidence that the specified work is constructed in compliance with the contract documents and the intent of applicable codes including Sections 106 and 1704 of the 2006 International Building Code (IBC) as adopted by the current State Building Code.
4. Structural testing and special inspection services are intended to assist in determining probable compliance of the work with requirements specified. These services do not relieve the Contractor of responsibility for compliance with the requirements of the contract documents.

B. Conditions

1. If inspection of fabricator's work is required, the Owner's representative may require testing and inspection of the work at the plant, before shipment. Owner, Architect and SER reserve the right to reject material not complying with the Contract Documents.
2. Testing and inspection shall be performed in accordance with the industry standard used as the reference for the specific material or procedure unless other criteria are specified. In the absence of a reference standard, tests shall be performed in accordance with generally accepted industry standards.
3. Work shall be checked as it progresses. Failure to detect any defective work or materials shall not prevent later rejection if defective work or materials are discovered, nor shall it obligate Owner to accept such work.
4. Structural testing, special inspection, and periodic inspections by the Building Official do not preclude the normal field involvement and site observations by Architect or SER.
5. Structural testing, special inspection, and periodic inspections by the Building Official do not relieve the Contractor of any responsibility to complete the work in accordance with the approved drawings and specifications.
6. Testing agents and/or special inspectors may not waive or alter contract requirements, or approve or accept any portion of the work unless specifically authorized by the Architect or SER. They may not assume any duties of the Contractor, and they have no authority to stop or reject work.

1.2 RELATED REQUIREMENTS

A. Drawings and general provisions of the Contract, including General and Supplementary Conditions and Division 1 Specifications apply to this section.

1.3 DEFINITIONS

- A. Testing: Evaluation of systems, primarily requiring physical manipulation and analysis of materials, in accordance with approved standards.
- B. Inspection: Evaluation of systems, primarily requiring observation and engineering judgment.
- C. Structural Special Inspections: Structural Testing and Special Inspection include items required by the 2006 IBC Section 1704 as adopted by the current State Building Code, and other items, which in the professional judgment of the Structural Engineer of Record, are critical to the integrity of the building structure and are indicated to be performed under the requirements of this section. They do not include special inspections for non-structural items such as earthwork, fireproofing, EIFS, and smoke control.
- D. Conventional Testing and Inspection: Conventional testing and inspection services herein describe those items not specifically required by code but may be considered essential to the proper performance of the building systems.
- E. Architect of Record: The prime consultant in charge of overall design and coordination of the project.
- F. Structural Engineer of Record (SER): The Licensed Engineer in responsible charge of the structural design for the project.
- G. Licensed Structural Engineer: A professional engineer with education and experience in the design of structures similar to this project licensed to practice in the state in which the project is located.
- H. Testing Agency (TA): The properly qualified firm performing testing services.
- I. Special Inspector (SI): A properly qualified individual or firm performing special inspections.
- J. Building Official: The Officer or his duly authorized representative charged with the administration and enforcement of the Building Code for the project.
- K. Continuous: The full-time observation of work requiring special inspection by an approved special inspector who is present in the area where the work is being performed.
- L. Periodic: The part-time or intermittent observation of work requiring special inspection by an approved special inspector who is present in the area where the work is being performed.

1.4 REFERENCES

- A. ASTM E329-02 – Specification for Agencies Engaged in the Testing and/or Inspection of Materials Used in Construction.
- B. ASTM E543-02 - Practice for Agencies Performing of Non-destructive Testing.
- C. ASTM C1077-02 - Practice for Laboratories Testing Concrete and Concrete Aggregates for Use in Construction and Criteria for Laboratory Evaluation.
- D. ASTM C1093-95 - Practice for the Accreditation of Testing Agencies for Unit Masonry.
- E. ASTM D3740-01 - Practice for Minimum Requirements for Agencies Engaged in the Testing and/or Inspection of Soil and Rock as Used in Engineering Design and Construction.
- F. Current State Building Code.
- G. International Building Code (IBC), 2006.

1.5 QUALIFICATIONS

- A. Testing Agency: an approved independent testing agency acceptable to Owner, Architect, SER, meeting requirements noted below:
 - 1. Authorized to operate in the State in which the project is located and experienced with the requirements and testing methods specified in the Contract Documents.
 - 2. Meet applicable requirements of references stated in paragraph 1.04.
 - 3. Have available testing equipment that is calibrated, at reasonable intervals, by devices of accuracy traceable to either the National Bureau of Standards, or to accepted values of natural physical constants.
 - 4. Provide individuals performing tests and taking samples with appropriate certifications for work performed.
- B. Special inspector: Either an appropriately certified inspector or a civil/structural engineer performing under the direct supervision of a licensed engineer (as defined earlier in this section) and acceptable to the SER and Building official. Unique special inspector requirements, for specific materials and systems, are noted in related technical specifications sections.

1.6 RESPONSIBILITIES

- A. Special Structural Testing and Inspection
 - 1. Special Inspectors:
 - a. Inspect the work assigned for conformance with the building department approved plans, specifications, and applicable material and workmanship provisions of the code. Perform inspections in a timely manner to avoid delay of work.
 - b. Bring nonconforming items to the immediate attention of the contractor for correction. If not corrected within 24 hours, or if inspector will not be on site the following day, bring to the attention of the SER by the end of the business day. If uncorrected after a reasonable period of time, bring to the attention of the Building Official, and to the Architect. Notify SER immediately if non-conforming items are enclosed, embedded, or obscured prior to verification of correction.
 - c. Submit inspection reports to the Building Official, Contractor, the Architect, the SER, and other designated persons in accordance with the structural testing and special inspection schedule.
 - d. Submit a final signed report stating whether the work requiring special inspection was, to the best of his/her knowledge, in conformance with the approved plans, specifications and the applicable workmanship provisions of the code.
 - e. Sign the structural testing and special inspection schedule in conjunction with other responsible parties.
 - f. Attend a pre-construction meeting to review scope of special inspection.
 - 2. Testing Agency:
 - a. Test the work assigned for conformance with the building department approved plans, specifications, and applicable material provisions of the documents. Perform tests in a timely manner to avoid delay of work.
 - b. Submit test reports to the Building Official, Contractor, the Architect, the SER, and other designated persons in accordance with the structural testing and special inspection schedule.
 - c. Sign the structural testing and special inspection schedule in conjunction with other responsible parties.
 - d. Attend a pre-construction meeting to review scope of structural testing.

3. Contractor:

- a. Attend a pre-construction meeting to review scope of structural testing and special inspection.
- b. Post or make available the structural testing and special inspection schedule within its office at the job site. Also, provide adequate notification to those parties designated on the schedule so they may properly prepare for and schedule their work.
- c. Provide special inspectors access to the approved plans and specifications at the job site.
- d. Review all reports issued by special inspectors.
- e. Retain, at the job site, all reports submitted by the special inspectors for review on the Building Official's request.
- f. Correct deficiencies identified in inspection or testing reports in a timely manner.
- g. Provide safe access to the work requiring inspection or testing.
- h. Provide labor and facilities to provide access to the work, to obtain, handle and deliver samples, to facilitate testing and inspection and for storage and curing of test samples.
- i. Verify conformance of the work with specified construction tolerances.
- j. Inspections by the Building Official: Provide adequate notice for inspectors performed by the building official, as requested by the IBC section 109, the current State Building Code, and local ordinances.
- k. Sign the structural testing and special inspection schedule in conjunction with other responsible parties prior to commencing construction.

4. Fabricator:

- a. Submit a Certificate of Compliance to the Building Official, Special Inspector, and SER that the work was performed in accordance with the approved plans and specifications.
- b. Sign the structural testing and special inspection schedule in conjunction with other responsible parties prior to commencing construction.

5. Owner:

- a. Establish direct funding to provide for cost of structural testing and special inspection services.
- b. Provide special inspector with approved plans, specifications and approved shop drawings.
- c. Provide special inspectors and testing agencies with full access to the site at all times.
- d. Sign the structural testing and special inspection schedule in conjunction with other responsible parties.

B. Conventional Testing and Inspection

1. Testing Agency:

- a. Test or inspect the work assigned, for conformance with building department approved plans, specifications and applicable workmanship provisions of the IBC.
- b. Bring non-conforming items to the immediate attention of the Contractor, and if uncorrected to the Architect of Record.
- c. Submit test and/or inspection reports to the Architect of Record, the Contractor and other designated persons.

2. Contractor:

- a. Provide adequate notification to testing agency so they may properly prepare for and schedule their work.
- b. Provide testing agency with access to the approved design drawings, approved shop drawings and specifications at the job site.
- c. Correct in a timely manner, deficiencies identified in test and/or inspection reports.
- d. Provide testing agency with safe access to the work requiring testing and inspection.
- e. Provide labor and facilities to provide access to the work and to obtain and handle samples, to facilitate testing and inspection and for storage and curing of test samples.
- f. Verification of conformance of the work within specified construction tolerances is solely the Contractor's responsibility.

C. Inspections by Building Official

1. Contractor shall provide adequate notice for inspections performed by the Building Official, as required by the 2006 IBC, the Minnesota State Building code, and local ordinance.

D. Periodic Site Observations by Design Consultant

1. Special structural testing and inspection, conventional testing and inspection, and periodic inspections by the building Official do not preclude the normal field involvement and site observations by Architect or Structural Engineer of Record, nor shall it relieve the Contractor of any responsibility to complete the work in accordance with the approved drawings and specifications.

E. Limits of Authority

1. Testing agents and/or special inspectors may not waive or alter contract requirements, or approve or accept any portion of the work unless specifically authorized by the Architect or Structural Engineer of Record. They may not assume any duties of the Contractor, and they have no authority to stop or reject "Work".

2. PAYMENT:

a. Contractor, will employ and pay for services of the special inspectors to perform required structural testing and special inspection.

b. Contractor shall employ and pay for services of the testing agency to perform required Conventional Testing and Inspection

c. Unless noted otherwise, the Contractor shall provide and pay for all materials, samples, mock-ups, and assemblies required for testing and inspection and shall pay for shipping costs related to delivery of such items. Testing agency will pay for shipping costs of samples transported from site to lab.

d. If items requiring testing or inspection are enclosed, embedded or obscured prior to testing or inspection or if such items are placed without tests or inspections, the Contractor shall pay for the costs of any exploratory work deemed necessary by the Architect/Engineer to verify compliance with the Contract Documents.

e. Contractor shall pay for the costs of any retests or re-inspections caused by the following:

1. Work which does not comply with the Contract Documents based on initial tests or inspections.

2. Work which is later revised or replaced by the Contractor. This does not include revisions requested by the Owner.

1.8 INSPECTION NOTICE

A. Contractor shall provide a minimum of 24 hours notice for all items requiring testing or inspection. Items requiring testing and inspection services prior to or during placement shall not be placed until testing and inspection services are available. Items requiring testing and inspection services after placement shall not be enclosed or obscured until testing and inspection services are performed.

1.9 REPORTS

A. Testing agency and special inspectors shall submit reports for structural testing and special inspections in a timely manner to the Contractor, Building Official, SER, and Architect of Record. Provide reports of daily activities to the SER and Contractor. Submit reports to the Contractor on a daily basis and to the SER on a daily or weekly basis. Provide summary reports to the Building Official and Architect unless they request otherwise.

B. Provide reports for ongoing work, containing the information noted below:

1. Date issued

2. Project title and number

3. Firm name and address

4. Name and signature of tester or inspector

5. Date and time of sampling, test or inspection

6. Identification of product and specification section

7. Location in project, including elevations, grid location and detail

8. Type of test or inspection

9. Whether test specimens, test results or observations indicate compliance with Contract Documents.

10. Types and locations of discrepancies found in work.

11. Work required performed to correct discrepancies and work performed to correct previously noted discrepancies. Discrepancies corrected during an inspection need not be reported.

12. Submit certified final special inspection report stating that, to the best of the special inspector's knowledge, the work requiring special inspection conformed to the Construction Documents.

1.10 FREQUENCY OF TESTING AND INSPECTION

A. For detailed requirements, see individual technical specification sections and the structural testing and special inspection schedule of this specification section.

1.11 PROTECTION AND REPAIR

A. Upon completion of testing, sample-taking, or inspection, the Contractor shall repair damaged work and restore substrates and finishes to eliminate deficiencies, including deficiencies in the visual qualities of exposed surfaces, as judged solely by the Architect/SER. Protect work exposed by or for testing and/or inspection and protect repaired work. Repair and protection is the Contractor's responsibility, regardless of the assignment of responsibility for testing and/or inspection.

1.12 TESTS TO DEMONSTRATE QUALIFICATION

A. Any tests required to qualify the Contractor, or the workers for any phase of the work, shall be performed at no additional cost to the Owner.

B. If the Contractor proposed a product material, method, or other system that has not been pre-qualified, the Architect/SER may require applicable tests to establish a basis for acceptance or rejection. The Contractor shall pay for these tests.

C. The Architect/SER reserves the right to require certification or other proof that the system proposed is in compliance with specified tests, criteria or standards. A representative of an independent testing agency shall sign the certificate.

1.13 STRUCTURAL TESTING AND SPECIAL INSPECTION SCHEDULE

A. The parties involved shall complete and sign the structural testing and special inspection schedule. Schedule to be complete at time of permit issuance.

B. The completed schedule is an element of the construction documents and after permit issuance, becomes part of the building department approved plans and specifications. (See attached Structural and Special Inspection Statement of Special Inspections & Structural Testing and Special Inspection Program Summary Schedule)

SEE ATTACHED STRUCTURAL TESTING AND SPECIAL INSPECTION STATEMENT OF SPECIAL INSPECTIONS & STRUCTURAL TESTING AND SPECIAL INSPECTION PROGRAM SUMMARY SCHEDULE – REFER ALSO TO STRUCTURAL PLANS FOR ADDITIONAL INFORMATION.

PART 1 GENERAL**1.1 SECTION INCLUDES**

- A. Temporary Utilities: Electricity, lighting, heat, ventilation, telephone service, water, and sanitary facilities.
- B. Temporary Controls: Barriers, enclosures and fencing, water control, exterior enclosures, protection of the Work, and security.
- C. Construction Facilities: progress cleaning, field office, parking, removal of utilities, facilities and controls.
- D. Job Sign

1.2 RELATED SECTIONS

- A. Section 01 77 00 - Project Closeout: Final cleaning.

1.3 TEMPORARY ELECTRICITY

- A. Provide and pay for power service required from Utility source.
- B. Provide temporary electric feeder from power poles electrical service at location as required.
- C. Provide power outlets for construction operations, with branch wiring and distribution boxes located where required. Provide flexible power cords as required.
- D. Provide main service disconnect and over current protection at convenient location feeder switch at source distribution equipment meter.
- E. Permanent convenience receptacles may be utilized during construction.
- F. Provide adequate distribution equipment, wiring, and outlets to provide single phase branch circuits for power and lighting.
 - 1. Provide 20 ampere duplex outlets, single phase circuits for power tools.
 - 2. Provide 20 ampere, single phase branch circuits for lighting.

1.4 TEMPORARY LIGHTING

- A. Provide and maintain incandescent lighting for construction operations to achieve a minimum lighting level of 2 watt/sq ft.
- B. Permanent building lighting may be utilized during construction.
- C. Maintain lighting and provide routine repairs.

1.5 TEMPORARY HEAT

- A. The Contractor shall provide and pay for heat devices and heat as required to maintain specified conditions for construction operations.
- B. Permanent equipment may not be used for temporary heating.
- C. Maintain minimum ambient temperature of 50 degrees F in areas where construction is in progress, unless indicated otherwise in specifications.

1.6 TEMPORARY VENTILATION

- A. Ventilate enclosed areas to assist cure of materials, dissipate humidity, and to prevent accumulation of dust, fumes, vapors, or gases.

1.7 TELEPHONE SERVICE

- A. Provide cellular telephone service as required.

1.8 TEMPORARY WATER SERVICE

- A. Provide, maintain and pay for suitable quality water service required for construction operations.
- B. Provide temporary pipe insulation to prevent freezing.
- C. Permanent building water may be utilized during construction.
- D. Maintain water and provide routine repairs.

1.9 TEMPORARY SANITARY FACILITIES

- A. Provide temporary sanitary facilities as required.

1.10 BARRIERS, ENCLOSURES AND FENCING

- A. Provide barriers, enclosures and fencing as required to prevent unauthorized entry to construction areas.

1.11 WATER CONTROL

- A. Grade site to drain. Maintain excavations free of water. Provide, operate, and maintain pumping equipment.
- B. Protect site from puddling or running water. Provide water barriers as required to protect site from soil erosion. Provide erosion control as required by authorities having jurisdiction.

1.12 EXTERIOR ENCLOSURES

A. Provide temporary insulated weather-tight closure of exterior openings to accommodate acceptable working conditions and protection for Products, to allow for temporary heating and maintenance of required ambient temperatures identified in individual specification Sections, and to prevent entry of unauthorized persons. Provide access doors with self-closing hardware and locks.

1.13 PROTECTION OF INSTALLED WORK

- A. Protect installed Work and provide special protection where specified in individual specification Sections.
- B. Provide temporary and removable protection for installed Products. Control activity in immediate work area to minimize damage.
- C. Provide protective coverings at walls, projections, jambs, sills, and soffits of openings.
- D. Protect finished floors, stairs, and other surfaces from traffic, dirt, wear, damage, or movement of heavy objects, by protecting with durable sheet materials.
- E. Prohibit traffic or storage upon waterproofed or roofed surfaces. If traffic or activity is necessary, obtain recommendations for protection from waterproofing or roofing material manufacturer.
- F. Prohibit traffic from landscaped areas.

1.14 SECURITY

A. Provide security and facilities to protect Work, and Owner's operations from unauthorized entry, vandalism, or theft.

1.15 PROGRESS CLEANING

- A. Maintain areas free of waste materials, debris, and rubbish. Maintain site in a clean and orderly condition.
- B. Remove debris and rubbish from pipe chases, plenums, attics, crawl spaces, and other closed or remote spaces, prior to enclosing the space.
- C. Broom and vacuum clean interior areas prior to start of surface finishing, and continue cleaning to eliminate dust.
- D. Remove waste materials, debris, and rubbish from site daily and dispose off-site.

1.16 FIELD OFFICES AND SHEDS

- A. Individual contractors may provide offices, location to be coordinated by Architect.
- B. Locate offices and sheds a minimum distance of 30 feet from existing and new structures.

1.17 PARKING

A. As permitted by Owner.

1.18 REMOVAL OF UTILITIES, FACILITIES, AND CONTROLS

- A. Remove temporary above grade or buried utilities, equipment, facilities, materials, prior to Substantial Completion.
- B. Clean and repair damage caused by installation or use of temporary work.
- C. Restore existing facilities used during construction to original condition. Restore permanent facilities used during construction to specified condition.

1.19 JOB SIGN

A. Install 4' x 8' plywood job sign as shown on the drawings. Sign to be located by Architect/Engineer. Sign to be attached to 4" x 4" wood posts provided and set by Contractor. Sign to be returned to owner in good condition at end of job.

PART 1 GENERAL**1.01 SECTION INCLUDES**

- A. Construction procedures to promote adequate indoor air quality after construction.
- B. Building flush-out after construction and before occupancy.
- C. Testing indoor air quality after completion of construction.
- D. Testing air change effectiveness after completion of construction.
- E. Testing residential unit air isolation.

1.02 PROJECT GOALS

- A. Dust and Airborne Particulates: Prevent deposition of dust and other particulates in HVAC ducts and equipment.
 - 1. Cleaning of ductwork is not contemplated under this Contract.
 - 2. Contractor shall bear the cost of cleaning required due to failure to protect ducts and equipment from construction dust.
- B. Airborne Contaminants: Procedures and products have been specified to minimize indoor air pollutants.
 - 1. Furnish products meeting the specifications.
 - 2. Avoid construction practices that could result in contamination of installed products leading to indoor air pollution.
- C. Residential Units Air Isolation: Units have been designed with impermeable party walls and sealed openings in walls and floors.

1.03 RELATED REQUIREMENTS

- A. Section 01 3329 - Green Building Requirements.
- B. Section 01 6116 - Volatile Organic Compound (VOC) Content Restrictions.

1.04 REFERENCE STANDARDS

- A. ASHRAE Std 129 - Measuring Air-Change Effectiveness; most recent publication.
- B. ASTM D5197 - Standard Test Method for Determination of Formaldehyde and Other Carbonyl Compounds in Air (Active Sampler Methodology); 2009.
- C. ASTM E779 - Standard Test Method for Determining Air Leakage Rate by Fan Pressurization; most recent publication.
- D. CAL (CDPH SM) - Standard Method for the Testing and Evaluation of Volatile Organic Chemical Emissions from Indoor Sources Using Environmental Chambers; California Department of Public Health; most recent publication.
- E. EPA 600/4-90/010 - Compendium of Methods for the Determination of Air Pollutants in Indoor Air, most recent publication.
- F. EPA 625/R-96/010b - Compendium of Methods for the Determination of Toxic Organic Compounds in Ambient Air, most recent publication.
- G. SMACNA (OCC) - IAQ Guidelines for Occupied Buildings Under Construction; most recent publication.

1.05 DEFINITIONS

- A. Adsorptive Materials: Gypsum board, acoustical ceiling tile and panels, carpet and carpet tile, fabrics, fibrous insulation, and other similar products.
- B. Contaminants: Gases, vapors, regulated pollutants, airborne mold and mildew, and the like, as specified.
- C. Particulates: Dust, dirt, and other airborne solid matter.
- D. Wet Work: Concrete, plaster, coatings, and other products that emit water vapor or volatile organic compounds during installation, drying, or curing.

1.06 SUBMITTALS

- A. See Section 01 3000 - Administrative Requirements, for submittal procedures.
- B. Indoor Air Quality Management Plan: Describe in detail measures to be taken to promote adequate indoor air quality upon completion; use SMACNA (OCC) as a guide.
 - 1. Submit not less than 60 days before enclosure of building.
 - 2. Identify potential sources of odor and dust.
 - 3. Identify construction activities likely to produce odor or dust.
 - 4. Identify areas of project potentially affected, especially occupied areas.
 - 5. Evaluate potential problems by severity and describe methods of control.
 - 6. Describe construction ventilation to be provided, including type and duration of ventilation, use of permanent HVAC systems, types of filters and schedule for replacement of filters.
 - 7. Describe cleaning and dust control procedures.
- C. Interior Finishes Installation Schedule: Identify each interior finish that either generates odors, moisture, or vapors or is susceptible to adsorption of odors and vapors, and indicate air handling zone, sequence of application, and curing times.

D. Duct and Terminal Unit Inspection Report.

E. Air Contaminant Test Plan: Identify:

1. Testing agency qualifications.
2. Locations and scheduling of air sampling.
3. Test procedures, in detail.
4. Test instruments and apparatus.
5. Sampling methods.

F. Air Contaminant Test Reports: Show:

1. Location where each sample was taken, and time.
2. Test values for each air sample; average the values of each set of 3.
3. HVAC operating conditions.
4. Certification of test equipment calibration.
5. Other conditions or discrepancies that might have influenced results.

G. Ventilation Effectiveness Test Plan: Identify:

1. Testing agency qualifications.
2. Description of test spaces, including locations of air sampling.
3. Test procedures, in detail; state whether tracer gas decay or step-up will be used.
4. Test instruments and apparatus; identify tracer gas to be used.
5. Sampling methods.

H. Ventilation Effectiveness Test Reports: Show:

1. Include preliminary tests of instruments and apparatus and of test spaces.
2. Calculation of ventilation effectiveness, E.
3. Location where each sample was taken, and time.
4. Test values for each air sample.
5. HVAC operating conditions.
6. Other information specified in ASHRAE Std 129.
7. Other conditions or discrepancies that might have influenced results.

I. Residential Units Air Isolation Test Plan: Identify:

1. Testing agency qualifications.
2. Description of test spaces, including locations of air sampling.
3. Test procedures, in detail.
4. Test instruments and apparatus; identify tracer gas to be used.
5. Sampling methods.

J. Residential Units Air Isolation Reports: Show:

1. Include preliminary tests of instruments and apparatus.
2. Include inspection of membrane seals in test spaces.
3. HVAC operating conditions.
4. Location where each sample was taken, and time.
5. Test values for each air sample.
6. Other information specified in ASHRAE Std 129.
7. Other conditions or discrepancies that might have influenced results.

PART 2 PRODUCTS

2.01 MATERIALS

A. Low VOC Materials: See other sections for specific requirements for materials with low VOC content.

PART 3 EXECUTION**3.01 CONSTRUCTION PROCEDURES**

- A. Prevent the absorption of moisture and humidity by adsorptive materials by:
1. Sequencing the delivery of such materials so that they are not present in the building until wet work is completed and dry.
 2. Delivery and storage of such materials in fully sealed moisture-impermeable packaging.
 3. Provide sufficient ventilation for drying within reasonable time frame.
- B. Begin construction ventilation when building is substantially enclosed.
- C. Do not store construction materials or waste in mechanical or electrical rooms.
- D. Prior to use of return air ductwork without intake filters clean up and remove dust and debris generated by construction activities.
1. Inspect duct intakes, return air grilles, and terminal units for dust.
 2. Clean plenum spaces, including top sides of lay-in ceilings, outsides of ducts, tops of pipes and conduit.
 3. Clean tops of doors and frames.
 4. Clean mechanical and electrical rooms, including tops of pipes, ducts, and conduit, equipment, and supports.
 5. Clean return plenums of air handling units.
 6. Remove intake filters last, after cleaning is complete.
- E. Do not perform dusty or dirty work after starting use of return air ducts without intake filters.
- F. Use other relevant recommendations of SMACNA (OCC) for avoiding unnecessary contamination due to construction procedures.

3.02 BUILDING FLUSH-OUT

- A. Contractor's Option: Either full continuous flush-out OR satisfactory air contaminant testing is required, not both.
- B. Perform building flush-out before occupancy.
- C. Do not start flush-out until:
1. All construction is complete.
 2. HVAC systems have been tested, adjusted, and balanced for proper operation.
 3. Inspection of inside of return air ducts and terminal units confirms that cleaning is not necessary.
 4. New HVAC filtration media have been installed.
- D. Building Flush-Out: Operate all ventilation systems at normal flow rates with 100 percent outside air until a total air volume of 14,000 cubic feet per square foot (4500 cubic meters per square meter) of floor area has been supplied.
1. Obtain Owner's concurrence that construction is complete enough before beginning flush-out.
 2. Maintain interior temperature of at least 60 degrees F (15 degrees C) and interior relative humidity no higher than 60 percent.
 3. If additional construction involving materials that produce particulates or any of the specified contaminants is conducted during flush-out, start flush-out over.
 4. If interior spaces must be occupied prior to completion of the flush-out, supply a minimum of 25 percent of the total air volume prior to occupancy, and:
 - a. Begin ventilation at least three hours prior to daily occupancy.
 - b. Continue ventilation during all occupied periods.
 - c. Provide minimum outside air volume of 0.30 cfm per square foot (0.0015 cu m/s/sq m) or design minimum outside air rate, whichever is greater.
- E. Install new HVAC filtration media after completion of flush-out and before occupancy or further testing.

3.03 AIR CONTAMINANT TESTING

- A. Contractor's Option: Either full continuous flush-out, or satisfactory air contaminant testing is required, not both.
- B. Perform air contaminant testing before occupancy.
- C. Do not start air contaminant testing until:
1. All construction is complete, including interior finishes.
 2. HVAC systems have been tested, adjusted, and balanced for proper operation.
 3. New HVAC filtration media have been installed.
- D. Indoor Air Samples: Collect from spaces representative of occupied areas:
1. Collect samples while operable windows and exterior doors are closed, HVAC system is running normally as if occupied, with design minimum outdoor air, but with the building unoccupied.
 2. Collect samples from spaces in each contiguous floor area in each air handler zone, but not less than one sample per 25,000 square feet (2300 square meters); take samples from areas having the least ventilation and those having the greatest presumed source strength.
 3. Collect samples from height from 36 inches (915 mm) to 72 inches (1830 mm) above floor.

4. Collect samples from same locations on 3 consecutive days during normal business hours; average the results of each set of 3 samples.
5. Exception: Areas with normal very high outside air ventilation rates, such as laboratories, do not need to be tested.
6. When retesting the same building areas, take samples from at least the same locations as in first test.

E. Outdoor Air Samples: Collect samples at outside air intake of each air handler at the same time as indoor samples are taken.

F. Analyze air samples and submit report.

G. Air Contaminant Concentration Limits:

1. Formaldehyde: Not more than 27 parts per billion.
2. PM10 Particulates: Not more than 50 micrograms per cubic meter.
3. Total Volatile Organic Compounds (TVOCs): Not more than 500 micrograms per cubic meter.
4. Chemicals Listed in CAL (CDPH SM) Table 4-1, except Formaldehyde: Allowable concentrations listed in Table 4-1.
5. Carbon Monoxide: Not more than 9 parts per million and not more than 2 parts per million higher than outdoor air.

H. Air Contaminant Concentration Test Methods:

1. Formaldehyde: ASTM D5197, EPA 625/R-96/010b Method TO-11A, or EPA 600/4-90/010 Method IP-6.
2. Particulates: EPA 600/4-90/010 Method IP-10.
3. Total Volatile Organic Compounds (TVOC): EPA 625/R-96/010b Method TO-1, TO-15, or TO-17; or EPA 600/4-90/010 Method IP-1.
4. Chemicals Listed in CAL (CDPH SM) Table 4-1, except Formaldehyde: ASTM D5197, or EPA 625/R-96/010b Method TO-1, TO-15, or TO-17.
5. Carbon Monoxide: EPA 600/4-90/010 Method IP-3, plus measure outdoor air; measure in ppm; report both indoor and outdoor measurements.

3.04 VENTILATION EFFECTIVENESS TESTING

A. Perform ventilation effectiveness testing before occupancy.

B. Do not begin ventilation effectiveness testing until:

1. HVAC testing, adjusting, and balancing has been satisfactorily completed.
2. Building flush-out or air contaminant testing has been completed satisfactorily.
3. New HVAC filtration media have been installed.

C. Test each air handler zone in accordance with ASHRAE Std 129.

D. If calculated air change effectiveness for a particular zone is less than 0.9 due to inadequate balancing of the system, adjust, and retest at no cost to Owner.

3.05 RESIDENTIAL UNITS AIR ISOLATION TESTING

A. Residential units have been designed to have an airtight sealed membrane between units; inspect membrane seal at the following locations and repair as required:

1. Between party walls and floor structure.
2. Between party walls and roof structure.
3. Around pipes, conduits, and ducts passing through floors and party walls.

B. Airtight membrane has been designed to limit leakage area to less than 1.25 square inches (806 square mm) per 100 square feet (square meter) of wall, ceiling, and floor area.

C. If possible, perform inspection and testing prior to covering up air seals in walls and floors.

D. Otherwise, perform testing after completion of construction but before occupancy.

E. Test airtight membrane in accordance with ASTM E779 or other appropriate method.

F. Acceptable Results: Maximum leakage of 0.23 cubic feet per minute per square foot (1.17 liters per second per square meter) at 1.1 pounds per square foot (50 Pa) pressure .

G. If test results show excess leakage area, reinspect, repair, and retest.

H. Test differential pressure between residential unit and pressurized hallway:

1. With the entrance door closed, operate the ventilation system in normal manner.
2. Take pressure readings for 15 minutes, with minimum of one measurement every 10 seconds.

PART 1 GENERAL**1.1 SECTION INCLUDES**

- A. Products.
- B. Transportation and handling.
- C. Storage and protection.
- D. Product options.

1.2 RELATED SECTIONS

- A. Section 00 21 13 - Instructions to Bidders: Product options and substitution procedures.
- B. Section 01 45 16 - Quality Control: Product quality monitoring.

1.3 PRODUCTS

- A. Products: Means new material, machinery, components, equipment, fixtures, and systems forming the Work. Does not include machinery and equipment used for preparation, fabrication, conveying and erection of the Work. Products may also include existing materials or components required for reuse.
- B. Do not use materials and equipment removed from existing premises, except as specifically permitted by the Contract Documents.
- C. Provide interchangeable components of the same manufacturer, for similar components.

1.4 TRANSPORTATION AND HANDLING

- A. Transport and handle products in accordance with manufacturer's instructions. Promptly inspect shipments to assure that products comply with requirements, quantities are correct, and products are undamaged.
- B. Provide equipment and personnel to handle products by methods to prevent soiling, disfigurement, or damage.

1.5 STORAGE AND PROTECTION

- A. Store and protect products in accordance with manufacturer's instructions, with seals and labels intact and legible. Store sensitive products in weather-tight, climate controlled enclosures.
- B. For exterior storage of fabricated products, place on sloped supports, above ground.
- C. Provide off-site storage and protection when site does not permit on-site storage or protection.
- D. Cover products subject to deterioration with impervious sheet covering. Provide ventilation to avoid condensation.
- E. Store loose granular materials on solid flat surfaces in a well-drained area. Provide mixing with foreign matter.
- F. Provide equipment and personnel to store products by methods to prevent soiling, disfigurement, or damage.
- G. Arrange storage of products to permit access for inspection. Periodically inspect to assure products are undamaged and are maintained under specified conditions.

1.6 PRODUCT OPTIONS

- A. Products Specified by Reference Standards or by Description Only: Any product meeting those standards or description.
- B. Products Specified by Naming One or More Manufacturers: Products of manufacturers named and meeting specifications, no options or substitutions allowed.
- C. Products Specified by Naming One or More Manufacturers with a Provision for Substitutions: Submit a request for substitution for any manufacturer not named.

PART 1 GENERAL**1.01 SECTION INCLUDES**

A. Requirements for VOC-Content-Restricted products.

1.02 RELATED REQUIREMENTS

A. Section 01 3300 - Submittal Procedures.

B. Section 01 4000 - Quality Requirements: Procedures for testing and certifications.

C. Section 01 6000 - Product Requirements: Fundamental product requirements, substitutions and product options, delivery, storage, and handling.

1.03 DEFINITIONS

A. VOC-Content-Restricted Products: All products in the following product categories, whether specified or not:

1. Interior paints and coatings.
2. Interior adhesives and sealants, including flooring adhesives.
3. Wet-applied roofing and waterproofing.
4. Other products when specifically stated in the specifications.

B. Interior of Building: Anywhere inside the exterior weather barrier.

C. Adhesives: All gunnable, trowelable, liquid-applied, and aerosol adhesives, whether specified or not; including flooring adhesives, resilient base adhesives, and pipe jointing adhesives.

D. Sealants: All gunnable, trowelable, and liquid-applied joint sealants and sealant primers, whether specified or not; including firestopping sealants and duct joint sealers.

1.04 REFERENCE STANDARDS

A. 40 CFR 59, Subpart D - National Volatile Organic Compound Emission Standards for Architectural Coatings; U.S. Environmental Protection Agency; current edition.

B. ASTM D3960 - Standard Practice for Determining Volatile Organic Compound (VOC) Content of Paints and Related Coatings; current edition.

C. CARB (ATCM) - Airborne Toxic Control Measure to Reduce Formaldehyde Emissions from Composite Wood Products; California Air Resources Board; current edition.

D. CARB (SCM) - Suggested Control Measure for Architectural Coatings; California Air Resources Board; current edition.

E. SCAQMD 1113 - South Coast Air Quality Management District Rule No.1113; current edition.

F. SCAQMD 1168 - South Coast Air Quality Management District Rule No.1168; current edition.

G. SCS (CPD) - SCS Certified Products; current listings at www.scscertified.com.

1.05 SUBMITTALS

A. See Section 01 3000 - Administrative Requirements, for submittal procedures.

B. Product Data: For each VOC-restricted product used in the project, submit evidence of compliance.

1.06 QUALITY ASSURANCE

A. VOC Content Test Method: 40 CFR 59, Subpart D (EPA Method 24), or ASTM D3960, unless otherwise indicated.

1. Evidence of Compliance: Acceptable types of evidence are:
 - a. Report of laboratory testing performed in accordance with requirements.
 - b. Published product data showing compliance with requirements.

B. Composite Wood Emissions Standard: CARB (ATCM) for ultra-low emitting formaldehyde (ULEF) resins.

1. Evidence of Compliance: Acceptable types of evidence are:
 - a. Current SCS "No Added Formaldehyde (NAF)" certification; www.scscertified.com.
 - b. Report of laboratory testing performed in accordance with requirements.
 - c. Published product data showing compliance with requirements.

C. Testing Agency Qualifications: Independent firm specializing in performing testing and inspections of the type specified in this section.

PART 2 PRODUCTS

2.01 MATERIALS

A. VOC-Content-Restricted Products: VOC content not greater than required by the following:

1. Adhesives, Including Flooring Adhesives: SCAQMD 1168 Rule.
2. Joint Sealants: SCAQMD 1168 Rule.
3. Paints and Coatings: Each color; most stringent of the following:
 - a. 40 CFR 59, Subpart D.
 - b. SCAQMD 1113 Rule.
 - c. CARB (SCM).
4. Wet-Applied Roofing and Waterproofing: Comply with requirements for paints and coatings.

PART 3 EXECUTION

3.01 FIELD QUALITY CONTROL

A. Owner reserves the right to reject non-compliant products, whether installed or not, and require their removal and replacement with compliant products at no extra cost to Owner.

B. Additional costs to restore indoor air quality due to installation of non-compliant products will be borne by Contractor.

PART 1 GENERAL**1.01 SECTION INCLUDES**

- A. Examination, preparation, and general installation procedures.
- B. Requirements for alterations work, including selective demolition, except removal, disposal, and/or remediation of hazardous materials and toxic substances.
- C. Pre-installation meetings.
- D. Cutting and patching.
- E. Surveying for laying out the work.
- F. Cleaning and protection.
- G. Starting of systems and equipment.
- H. Demonstration and instruction of Owner personnel.
- I. Closeout procedures, including Contractor's Correction Punch List, except payment procedures.
- J. General requirements for maintenance service.

1.02 RELATED REQUIREMENTS

- A. Section 01 1000 - Summary: Limitations on working in existing building; continued occupancy; work sequence; identification of salvaged and relocated materials.
- B. Section 01 3000 - Administrative Requirements: Submittals procedures.
- C. Section 01 4000 - Quality Requirements: Testing and inspection procedures.
- D. Section 01 5000 - Temporary Facilities and Controls: Temporary exterior enclosures.
- E. Section 01 5000 - Temporary Facilities and Controls: Temporary interior partitions.
- F. Section 01 7419 - Construction Waste Management and Disposal: Additional procedures for trash/waste removal, recycling, salvage, and reuse.
- G. Section 01 7800 - Closeout Submittals: Project record documents, operation and maintenance data, warranties and bonds.
- H. Section 07 8400 - Firestopping.

1.03 REFERENCE STANDARDS

- A. NFPA 241 - Standard for Safeguarding Construction, Alteration, and Demolition Operations; current version.

1.04 SUBMITTALS

- A. See Section 01 3000 - Administrative Requirements, for submittal procedures.
- B. Survey work: Submit name, address, and telephone number of Surveyor before starting survey work.
 - 1. On request, submit documentation verifying accuracy of survey work.
 - 2. Submit a copy of site drawing signed by the Land Surveyor, that the elevations and locations of the work are in conformance with Contract Documents.
 - 3. Submit surveys and survey logs for the project record.
- C. Cutting and Patching: Submit written request in advance of cutting or alteration that affects:
 - 1. Structural integrity of any element of Project.
 - 2. Integrity of weather exposed or moisture resistant element.
 - 3. Efficiency, maintenance, or safety of any operational element.
 - 4. Visual qualities of sight exposed elements.
 - 5. Work of Owner or separate Contractor.
- D. Project Record Documents:
 - 1. Contractor shall provide a final ALTA as-built survey completed by an ALTA land surveyor.
 - 2. Accurately record actual locations of capped and active utilities.

1.05 QUALIFICATIONS

- A. For survey work, employ a land surveyor registered in the State in which the Project is located and acceptable to Architect. Submit evidence of Surveyor's Errors and Omissions insurance coverage in the form of an Insurance Certificate.
- B. For design of temporary shoring and bracing, employ a Professional Engineer experienced in design of this type of work and licensed in the State in which the Project is located.

1.06 COORDINATION

- A. See Section 01 1000 for occupancy-related requirements.
- B. Coordinate scheduling, submittals, and work of the various sections of the Project Manual to ensure efficient and orderly sequence of installation of interdependent construction elements, with provisions for accommodating items installed later.
- C. Notify affected utility companies and comply with their requirements.
- D. Verify that utility requirements and characteristics of new operating equipment are compatible with building utilities. Coordinate work of various sections having interdependent responsibilities for installing, connecting to, and placing in service, such equipment.

- E. Coordinate space requirements, supports, and installation of mechanical and electrical work that are indicated diagrammatically on drawings. Follow routing indicated for pipes, ducts, and conduit, as closely as practicable; place runs parallel with lines of building. Utilize spaces efficiently to maximize accessibility for other installations, for maintenance, and for repairs.
- F. In finished areas except as otherwise indicated, conceal pipes, ducts, and wiring within the construction. Coordinate locations of fixtures and outlets with finish elements.
- G. Coordinate completion and clean-up of work of separate sections.
- H. After Owner occupancy of premises, coordinate access to site for correction of defective work and work not in accordance with Contract Documents, to minimize disruption of Owner's activities.

PART 2 PRODUCTS

2.01 PATCHING MATERIALS

- A. New Materials: As specified in product sections; match existing products and work for patching and extending work.
- B. Type and Quality of Existing Products: Determine by inspecting and testing products where necessary, referring to existing work as a standard.
- C. Product Substitution: For any proposed change in materials, submit request for substitution described in Section 016000 - Product Requirements.

PART 3 EXECUTION

3.01 EXAMINATION

- A. Verify that existing site conditions and substrate surfaces are acceptable for subsequent work. Start of work means acceptance of existing conditions.
- B. Verify that existing substrate is capable of structural support or attachment of new work being applied or attached.
- C. Examine and verify specific conditions described in individual specification sections.
- D. Take field measurements before confirming product orders or beginning fabrication, to minimize waste due to over-ordering or mis-fabrication.
- E. Verify that utility services are available, of the correct characteristics, and in the correct locations.
- F. Prior to Cutting: Examine existing conditions prior to commencing work, including elements subject to damage or movement during cutting and patching. After uncovering existing work, assess conditions affecting performance of work. Beginning of cutting or patching means acceptance of existing conditions.

3.02 PREPARATION

- A. Clean substrate surfaces prior to applying next material or substance.
- B. Seal cracks or openings of substrate prior to applying next material or substance.
- C. Apply manufacturer required or recommended substrate primer, sealer, or conditioner prior to applying any new material or substance in contact or bond.

3.03 PREINSTALLATION MEETINGS

- A. When required in individual specification sections, convene a preinstallation meeting at the site prior to commencing work of the section.
- B. Require attendance of parties directly affecting, or affected by, work of the specific section.
- C. Notify Architect four days in advance of meeting date.
- D. Prepare agenda and preside at meeting:
 - 1. Review conditions of examination, preparation and installation procedures.
 - 2. Review coordination with related work.
- E. Record minutes and distribute copies within two days after meeting to participants, with two copies to Architect, Owner, participants, and those affected by decisions made.

3.04 LAYING OUT THE WORK

- A. Verify locations of survey control points prior to starting work.
- B. Promptly notify Architect of any discrepancies discovered.
- C. Protect survey control points prior to starting site work; preserve permanent reference points during construction.
- D. Promptly report to Architect the loss or destruction of any reference point or relocation required because of changes in grades or other reasons.
- E. Replace dislocated survey control points based on original survey control. Make no changes without prior written notice to Architect.
- F. Utilize recognized engineering survey practices.

- G. Establish elevations, lines and levels. Locate and lay out by instrumentation and similar appropriate means:
1. Site improvements including pavements; stakes for grading, fill and topsoil placement; utility locations, slopes, and invert elevations.
 2. Grid or axis for structures.
 3. Building foundation, column locations, ground floor elevations.
- H. Periodically verify layouts by same means.
- I. Maintain a complete and accurate log of control and survey work as it progresses.

3.05 GENERAL INSTALLATION REQUIREMENTS

- A. Install products as specified in individual sections, in accordance with manufacturer's instructions and recommendations, and so as to avoid waste due to necessity for replacement.
- B. Make vertical elements plumb and horizontal elements level, unless otherwise indicated.
- C. Install equipment and fittings plumb and level, neatly aligned with adjacent vertical and horizontal lines, unless otherwise indicated.
- D. Make consistent texture on surfaces, with seamless transitions, unless otherwise indicated.
- E. Make neat transitions between different surfaces, maintaining texture and appearance.

3.06 ALTERATIONS

- A. Drawings showing existing construction and utilities are based on casual field observation and existing record documents only.
1. Verify that construction and utility arrangements are as indicated.
 2. Report discrepancies to Architect before disturbing existing installation.
 3. Beginning of alterations work constitutes acceptance of existing conditions.
- B. Keep areas in which alterations are being conducted separated from other areas that are still occupied.
1. Provide, erect, and maintain temporary dustproof partitions of construction indicated on drawings
- C. Maintain weatherproof exterior building enclosure except for interruptions required for replacement or modifications; take care to prevent water and humidity damage.
1. Where openings in exterior enclosure exist, provide construction to make exterior enclosure weatherproof.
 2. Insulate existing ducts or pipes that are exposed to outdoor ambient temperatures by alterations work.
- D. Remove existing work as indicated and as required to accomplish new work.
1. Remove rotted wood, corroded metals, and deteriorated masonry and concrete; replace with new construction specified.
 2. Remove items indicated on drawings.
 3. Relocate items indicated on drawings.
 4. Where new surface finishes are to be applied to existing work, perform removals, patch, and prepare existing surfaces as required to receive new finish; remove existing finish, if necessary, for successful application of new finish.
 5. Where new surface finishes are not specified or indicated, patch holes and damaged surfaces to match adjacent finished surfaces as closely as possible.
- E. Services (Including but not limited to HVAC, Plumbing, Fire Protection, Electrical, and Telecommunications): Remove, relocate, and extend existing systems to accommodate new construction.
1. Maintain existing active systems that are to remain in operation; maintain access to equipment and operational components; if necessary, modify installation to allow access or provide access panel.
 2. Where existing systems or equipment are not active and Contract Documents require reactivation, put back into operational condition; repair supply, distribution, and equipment as required.
 3. Where existing active systems serve occupied facilities but are to be replaced with new services, maintain existing systems in service until new systems are complete and ready for service.
 - a. Disable existing systems only to make switchovers and connections; minimize duration of outages.
 - b. See Section 01 1000 for other limitations on outages and required notifications.
 - c. Provide temporary connections as required to maintain existing systems in service.
 4. Verify that abandoned services serve only abandoned facilities.
 5. Remove abandoned pipe, ducts, conduits, and equipment, including those above accessible ceilings; remove back to source of supply where possible, otherwise cap stub and tag with identification; patch holes left by removal using materials specified for new construction.
- F. Protect existing work to remain.
1. Prevent movement of structure; provide shoring and bracing if necessary.
 2. Perform cutting to accomplish removals neatly and as specified for cutting new work.
 3. Repair adjacent construction and finishes damaged during removal work.

G. Adapt existing work to fit new work: Make as neat and smooth transition as possible.

1. When existing finished surfaces are cut so that a smooth transition with new work is not possible, terminate existing surface along a straight line at a natural line of division and make recommendation to Architect.
2. Where removal of partitions or walls results in adjacent spaces becoming one, rework floors, walls, and ceilings to a smooth plane without breaks, steps, or bulkheads.
3. Where a change of plane of 1/4 inch (6 mm) or more occurs in existing work, submit recommendation for providing a smooth transition for Architect review and request instructions.
4. Trim existing wood doors as necessary to clear new floor finish. Refinish trim as required.

H. Patching: Where the existing surface is not indicated to be refinished, patch to match the surface finish that existed prior to cutting. Where the surface is indicated to be refinished, patch so that the substrate is ready for the new finish.

I. Refinish existing surfaces as indicated:

1. Where rooms or spaces are indicated to be refinished, refinish all visible existing surfaces to remain to the specified condition for each material, with a neat transition to adjacent finishes.
2. If mechanical or electrical work is exposed accidentally during the work, re-cover and refinish to match.

J. Clean existing systems and equipment.

K. Remove demolition debris and abandoned items from alterations areas and dispose of off-site; do not burn or bury.

L. Do not begin new construction in alterations areas before demolition is complete.

M. Comply with all other applicable requirements of this section.

3.07 CUTTING AND PATCHING

A. Whenever possible, execute the work by methods that avoid cutting or patching.

B. See Alterations article above for additional requirements.

C. Perform whatever cutting and patching is necessary to:

1. Complete the work.
2. Fit products together to integrate with other work.
3. Provide openings for penetration of mechanical, electrical, and other services.
4. Match work that has been cut to adjacent work.
5. Repair areas adjacent to cuts to required condition.
6. Repair new work damaged by subsequent work.
7. Remove samples of installed work for testing when requested.
8. Remove and replace defective and non-conforming work.

D. Execute work by methods that avoid damage to other work and that will provide appropriate surfaces to receive patching and finishing. In existing work, minimize damage and restore to original condition.

E. Employ skilled and experienced installer to perform cutting for weather exposed and moisture resistant elements, and sight exposed surfaces.

F. Cut rigid materials using masonry saw or core drill. Pneumatic tools not allowed without prior approval.

G. Restore work with new products in accordance with requirements of Contract Documents.

H. Fit work air tight to pipes, sleeves, ducts, conduit, and other penetrations through surfaces.

I. At penetrations of fire rated walls, partitions, ceiling, or floor construction, completely seal voids with fire rated material in accordance with Section 07 8400, to full thickness of the penetrated element.

J. Patching:

1. Finish patched surfaces to match finish that existed prior to patching. On continuous surfaces, refinish to nearest intersection or natural break. For an assembly, refinish entire unit.
2. Match color, texture, and appearance.
3. Repair patched surfaces that are damaged, lifted, discolored, or showing other imperfections due to patching work. If defects are due to condition of substrate, repair substrate prior to repairing finish.

3.08 PROGRESS CLEANING

A. Maintain areas free of waste materials, debris, and rubbish. Maintain site in a clean and orderly condition.

B. Remove debris and rubbish from pipe chases, plenums, attics, crawl spaces, and other closed or remote spaces, prior to enclosing the space.

C. Broom and vacuum clean interior areas prior to start of surface finishing, and continue cleaning to eliminate dust.

D. Collect and remove waste materials, debris, and trash/rubbish from site periodically and dispose off-site; do not burn or bury.

3.09 PROTECTION OF INSTALLED WORK

- A. Protect installed work from damage by construction operations.
- B. Provide special protection where specified in individual specification sections.
- C. Provide temporary and removable protection for installed products. Control activity in immediate work area to prevent damage.
- D. Provide protective coverings at walls, projections, jambs, sills, and soffits of openings.
- E. Protect finished floors, stairs, and other surfaces from traffic, dirt, wear, damage, or movement of heavy objects, by protecting with durable sheet materials.
- F. Prohibit traffic or storage upon waterproofed or roofed surfaces. If traffic or activity is necessary, obtain recommendations for protection from waterproofing or roofing material manufacturer.
- G. Remove protective coverings when no longer needed; reuse or recycle coverings if possible.

3.10 SYSTEM STARTUP

- A. Coordinate schedule for start-up of various equipment and systems.
- B. Notify Architect and owner seven days prior to start-up of each item.
- C. Verify that each piece of equipment or system has been checked for proper lubrication, drive rotation, belt tension, control sequence, and for conditions that may cause damage.
- D. Verify tests, meter readings, and specified electrical characteristics agree with those required by the equipment or system manufacturer.
- E. Verify that wiring and support components for equipment are complete and tested.
- F. Execute start-up under supervision of applicable Contractor personnel and manufacturer's representative in accordance with manufacturers' instructions.
- G. When specified in individual specification Sections, require manufacturer to provide authorized representative to be present at site to inspect, check, and approve equipment or system installation prior to start-up, and to supervise placing equipment or system in operation.
- H. Submit a written report that equipment or system has been properly installed and is functioning correctly.

3.11 DEMONSTRATION AND INSTRUCTION

- A. Demonstrate operation and maintenance of products to Owner's personnel two weeks prior to date of Substantial Completion.
- B. Demonstrate start-up, operation, control, adjustment, trouble-shooting, servicing, maintenance, and shutdown of each item of equipment at scheduled time, at equipment location.
- C. For equipment or systems requiring seasonal operation, perform demonstration for other season within six months.
- D. Provide a qualified person who is knowledgeable about the Project to perform demonstration and instruction of owner personnel.
- E. Utilize operation and maintenance manuals as basis for instruction. Review contents of manual with Owner's personnel in detail to explain all aspects of operation and maintenance.
- F. Prepare and insert additional data in operations and maintenance manuals when need for additional data becomes apparent during instruction.

3.12 ADJUSTING

- A. Adjust operating products and equipment to ensure smooth and unhindered operation.

3.13 FINAL CLEANING

- A. Use cleaning materials that are nonhazardous.
- B. Clean interior and exterior glass, surfaces exposed to view; remove temporary labels, stains and foreign substances, polish transparent and glossy surfaces, vacuum carpeted and soft surfaces.
- C. Remove all labels that are not permanent. Do not paint or otherwise cover fire test labels or nameplates on mechanical and electrical equipment.
- D. Clean equipment and fixtures to a sanitary condition with cleaning materials appropriate to the surface and material being cleaned.
- E. Clean filters of operating equipment.
- F. Clean debris from roofs and drainage systems.
- G. Clean site; sweep paved areas, rake clean landscaped surfaces.
- H. Remove waste, surplus materials, trash/rubbish, and construction facilities from the site; dispose of in legal manner; do not burn or bury.
- I. Change all filters before building turnover. After landscaping is done, G.C. shall change all air filters prior to occupancy.

3.14 CLOSEOUT PROCEDURES

- A. Make submittals that are required by governing or other authorities.
- B. Accompany Project Coordinator on preliminary inspection to determine items to be listed for completion or correction in the Contractor's Correction Punch List for Contractor's Notice of Substantial Completion.
- C. Notify Architect when work is considered ready for Architect's Substantial Completion inspection.
- D. Submit written certification containing Contractor's Correction Punch List, that Contract Documents have been reviewed, work has been inspected, and that work is complete in accordance with Contract Documents and ready for Architect's Substantial Completion inspection.
- E. Conduct Substantial Completion inspection and create Final Correction Punch List containing Architect's and Contractor's comprehensive list of items identified to be completed or corrected and submit to Architect.
- F. Correct items of work listed in Final Correction Punch List and comply with requirements for access to Owner-occupied areas.
- G. Notify Architect when work is considered finally complete and ready for Architect's Substantial Completion final inspection.
- H. Complete items of work determined by Architect listed in executed Certificate of Substantial Completion.

3.15 MAINTENANCE

- A. Provide service and maintenance of components indicated in specification sections.
- B. Maintenance Period: As indicated in specification sections or, if not indicated, not less than one year from the Date of Substantial Completion or the length of the specified warranty, whichever is longer.
- C. Examine system components at a frequency consistent with reliable operation. Clean, adjust, and lubricate as required.
- D. Include systematic examination, adjustment, and lubrication of components. Repair or replace parts whenever required. Use parts produced by the manufacturer of the original component.
- E. Maintenance service shall not be assigned or transferred to any agent or subcontractor without prior written consent of the Owner.

PART 1 GENERAL**1.1 SECTION INCLUDES**

A. Requirements and limitations for cutting and patching of Work.

1.2 RELATED SECTIONS

A. Section 01 11 00 - Summary of Work.

B. Section 01 33 00 - Submittals.

C. Section 01 60 00 – Product Requirements.

D. Individual Product Specification Sections:

1. Cutting and patching incidental to work of the Section.
2. Advance notification to other Sections of openings required in work of those Sections.
3. Limitations on cutting structural.

1.3 SUBMITTALS

A. Submit written request in advance of cutting or alteration which affects:

1. Structural integrity of any element of Project.
2. Integrity of weather-exposed or moisture-resistant element.
3. Efficiency, maintenance, or safety of any operational element.
4. Visual qualities of sight exposed elements.
5. Work of Owner or separate contractor.

B. Include in request:

1. Identification of Project.
2. Location and description of affected work.
3. Necessity for cutting or alteration.
4. Description of proposed work, and products to be used.
5. Alternatives to cutting and patching.
6. Effect on work of Owner or separate contractor.
7. Written permission of affected separate contractor.
8. Date and time work will be executed.

PART 2 PRODUCTS**2.1 MATERIALS**

A. Primary Products: Those required for original installation.

B. Product Substitution: For any proposed change in materials, submit request for substitution under provisions of Section 01 60 00.

PART 3 EXECUTION**3.1 EXAMINATION**

A. Inspect existing conditions prior to commencing Work, including elements subject to damage or movement during cutting and patching.

B. After uncovering existing work, inspect conditions affecting performance of work.

C. Beginning of cutting or patching means acceptance of existing conditions.

3.2 PREPARATION

A. Provide temporary supports to ensure structural integrity of the Work. Provide devices and methods to protect other portions of Project from damage.

B. Provide protection from elements for areas which may be exposed by uncovering work.

C. Maintain excavations free of water.

3.3 CUTTING AND PATCHING

A. Execute cutting, fitting, and patching including excavation and fill to complete work.

B. Fit products together, to integrate with other work.

C. Uncover work to install ill-timed work.

D. Remove and replace defective or non-conforming work.

E. Remove samples of installed work for testing when requested.

F. Provide openings in the work for penetration of mechanical and electrical work.

3.4 PERFORMANCE

- A. Execute work by methods to avoid damage to other Work and provide appropriate surfaces to receive patching and finishing.
- B. Employ original installer to perform cutting and patching for weather exposed, moisture resistant elements, and sight-exposed surfaces.
- C. Cut rigid materials using masonry saw or core drill. Pneumatic tools not allowed without prior approval.
- D. Restore work with new products in accordance with requirements of Contract Documents.
- E. Fit work air tight to pipes, sleeves, ducts, conduit, and other penetrations through surfaces.
- F. At penetrations of fire rated walls, partitions, ceiling, or floor construction, completely seal voids with fire rated material to full thickness of the penetrated element.
- G. Refinish surfaces to match adjacent finish. For continuous surfaces, refinish to nearest intersection or natural break. For an assembly, refinish entire unit.

PROJECT SCOPE**A. SECTION INCLUDES Construction Waste Recycling**

- 1.1. Reuse & Recycling Goals
- 1.2. Material Handling Procedures.
- 1.3. Segregated Dumpsters definitions.
- 1.4. Education and Training
- 1.5. Waste Auditing Procedures

1.1 Reuse and Recycling Goals and Intent for construction waste recycling are as follows:

- a. Reduce and Reuse: It is intended that the project shall generate the least amount of waste possible and that methods shall be used that minimize waste due to error, poor planning, breakage, mishandling, contamination, or similar factors.

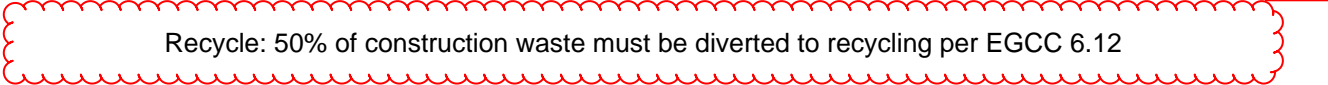
- b.  Recycle: 50% of construction waste must be diverted to recycling per EGCC 6.12

1.2. Materials Handling Procedures

- a. All Contractors and subcontractors are required to abide by the guidelines stated below. All contractors will use dumpsters provided by the General Contractor. The General Contractor shall provide and pay for these dumpsters. The General Contractor shall provide receipts to the owner to show recycling amounts. In doing so, the owner will be able to effectively track all materials entering the landfill or being recycled providing us with the most accurate reporting.
- b. Method Site Separation: This project will use the site separation method. Dumpsters will be placed on site, each one containing a different product. The workers on site will be responsible for placing the correct material in the correct dumpster. Each dumpster shall be labeled with easy to understand signs explaining what material belongs in that dumpster.
If a contractor contaminates a dumpster, that contractor will be responsible for any additional costs associated with re-sorting that dumpster and/ or additional tipping fees. This will be coordinated by the General Contractor.

1.3. Segregated Dumpsters and Material Definitions and Examples Recyclable Material Commingled Recyclables:

- a. Definition: bottles, cans, paper ,etc. that qualify as acceptable household recyclables
- b. Includes but not limited to: pop bottles, pop cans, office paper, newspaper, etc.
- c. Concrete, Brick and Masonry: Definition: any concrete, asphalt, and brick material with minimum rebar
Includes but not limited to: concrete slabs/ footings/ etc., block, brick, asphalt, masonry, etc.
- d. Cardboard: Definition: any non-contaminated corrugated cardboard. Notebook covers/ cereal box type cardboard is not corrugated and NON-Recyclable. Includes but not limited to: boxes from materials, equipment, etc.
- e. Metal: Definition: any clean/bare metal products. Includes but not limited to: duck work, metal piping, bare metal light fixtures, ceiling tile grid, wire, steel door frames, metal hardware, etc.
- f. Wood: Definition: any non-treated, non-painted, clean dimensional lumber/wood.
Includes but not limited to: pallets, crates, wood studs, etc.
- g. Disposed Material Construction & Demolition Debris (C&D): Definition: Waste or debris generated solely from construction of pavement, building or other structures. Includes but not limited to: ceiling tile, floor tile, gypsum board, insulation, shingles, windows, etc.
- h. Municipal Solid Waste (MSW): Definition: any garbage or refuse. The non-hazardous material that cannot be recycled, or disposed of in a C&D landfill. Included but not limited to: Lunch garbage, carpet pad, treated lumber, job trailer waste that cannot be recycled, etc.

1.4 Education and Training:

A kickoff meeting explaining that waste management plan shall be held at the beginning of the project, during the pre-construction meeting. The waste management plan and implementation shall also be discussed at all regular job site meetings, during work orientation, and on an ongoing basis on the job site.

1.5. Waste Auditing Procedures:

Contractors and subcontractors are responsible for daily site cleanup and ensuring that all containers are kept free of contamination. The owner shall be responsible for dumpster inspections, any dumpsters contaminated should be re-sorted. It's very important to eliminate dumpster contamination to a)avoid additional disposal fees and b)lower recycling rates.

1. PART 1 GENERAL**1.1 SECTION INCLUDES**

- A. Closeout procedures.
- B. Final cleaning.
- C. Adjusting.
- D. Project record documents.
- E. Operation and maintenance data.
- F. Warranties.
- G. Spare parts and maintenance materials.

1.2 RELATED SECTIONS

- A. Section 01 50 00 – Temporary Facilities and Controls.

1.3 CLOSEOUT PROCEDURES

- A. Submit written certification that Contract Documents have been reviewed, Work has been inspected, and that Work is complete in accordance with Contract Documents and ready for Architect/Engineer's inspection.
- B. Provide submittals to Architect/Engineer that are required by governing or other authorities.
- C. Submit final Application for Payment identifying total adjusted Contract Sum, previous payments, and sum remaining due.
- D. Owner will occupy all of the building as specified in Section 01 31 13.

1.4 FINAL CLEANING

- A. Execute final cleaning prior to final inspection.
- B. Clean interior and exterior glass and surfaces exposed to view; remove temporary labels, stains and foreign substances, polish transparent and glossy surfaces, vacuum carpeted and soft surfaces.
- C. Clean equipment and fixtures to a sanitary condition.
- D. Replace filters of operating equipment.
- E. Clean debris from roofs, and drainage systems.
- F. Clean site; sweep paved areas, rake clean landscaped surfaces.
- G. Remove waste and surplus materials, rubbish, and construction facilities from the site.

1.5 ADJUSTING

- A. Adjust operating Products and equipment to ensure smooth and unhindered operation.

1.6 PROJECT RECORD DOCUMENTS

- A. Maintain on site, one set of the following record documents; record actual revisions to the Work:
 - (1) Contract Drawings.
 - (2) Specifications.
 - (3) Addenda.
 - (4) Change Orders and other Modifications to the Contract.
 - (5) Reviewed shop drawings, product data, and samples.
- B. Store Record Documents separate from documents used for construction.
- C. Record information concurrent with construction progress.
- D. Specifications: Legibly mark and record at each Product section description of actual Products installed, including the following:
 - (1) Manufacturer's name and product model and number.
 - (2) Product substitutions or alternates utilized.
 - (3) Changes made by Addenda and Modifications.
- E. Record Documents and Shop Drawings: Legibly mark each item to record actual construction including:
 - (1) Measured depths of foundations in relation to finish [first] [main] floor datum.
 - (2) Measured horizontal and vertical locations of underground utilities and appurtenances, referenced to permanent surface improvements.
 - (3) Measured locations of internal utilities and appurtenances concealed in construction, referenced to visible and accessible features of the Work.
 - (4) Field changes of dimension and detail.
 - (5) Details not on original Contract Drawings.
- F. Energy star 3.0 check list
- G. Submit documents to Architect/Engineer with claim for final Application for Payment.

1.7 OPERATION AND MAINTENANCE DATA

- A. Submit two sets prior to final inspection, bound in 8-1/2 x 11 inch text pages, three D side ring capacity expansion binders with durable plastic covers.
- B. Prepare binder covers with printed title "OPERATION AND MAINTENANCE INSTRUCTIONS", title of project, and subject matter of binder when multiple binders are required.
- C. Internally subdivide the binder contents with permanent page dividers, logically organized as described below; with tab titling clearly printed under reinforced laminated plastic tabs.
- D. Contents: Prepare a Table of Contents for each volume, with each Product or system description identified, type on 24 pound white paper.
- E. Part 1: Directory, listing names, addresses, and telephone numbers of Architect/Engineer, Contractor, Subcontractors, and major equipment suppliers.
- F. Part 2: Operation and maintenance instructions, arranged by system and subdivided by specification section. For each category, identify names, addresses, and telephone numbers of Subcontractors and suppliers. Identify the following:
- (1) Significant design criteria.
 - (2) List of equipment.
 - (3) Parts list for each component.
 - (4) Operating instructions.
 - (5) Maintenance instructions for equipment and systems.
 - (6) Maintenance instructions for [special] finishes, including recommended cleaning methods and materials and special precautions identifying detrimental agents.
- G. Part 3: Project documents and certificates, including the following:
- (1) Shop drawings and product data.
 - (2) Air and water balance reports.
 - (3) Certificates.
 - (4) Photocopies of warranties and bonds.

1.8 WARRANTIES

- A. Provide duplicate notarized copies.
- B. Execute and assemble documents from Subcontractors, suppliers, and manufacturers.
- C. Provide Table of Contents and assemble in three D side ring binder with durable plastic cover.
- D. Submit prior to final Application for Payment.
- E. For items of Work delayed beyond date of Substantial Completion, provide updated submittal within ten days after acceptance, listing date of acceptance as start of warranty period.

1.9 SPARE PARTS AND MAINTENANCE MATERIALS

- A. Provide products, spare parts, maintenance and extra materials in quantities specified in individual specification Sections.
- B. Deliver to Project site and place in location as directed; obtain receipt prior to final payment.

Structural notes / specifications referenced on Structural Drawings Sheets by the Structural Engineer shall take precedence over (supercede) any of the written specifications that follow in this book.

PART 1 - GENERAL**1.1 DESCRIPTION**

A. Scope: Furnish, erect and remove forms for cast-in-place concrete

B. Additional Requirements Specified Elsewhere

1. Section 011100: Summary of Work
2. Section 013300: Submittals
3. Section 014516: Quality Control
4. Section 015000: Construction Facilities and Temporary Controls

C. Related Requirements Specified Elsewhere

1. Section 032000: Concrete Reinforcement
2. Section 033000: Cast-in-Place Concrete

1.2 QUALITY ASSURANCE**A. Design Criteria**

1. Design formwork for the loads, lateral pressure and allowable stresses outlined in ACI 347, Chapter 1 & 2

B. Allowable Tolerances

1. Variation from plumb a. Lines and surfaces of columns, piers, and walls 1) In any 10' of length: ¼" 2) Entire length: 1" b. Exposed corner columns, control joint grooves and other conspicuous lines 1) In any 20' of length: ¼" 2) Entire length: ½"
 2. Variation from level or specified grade a. Exposed sills, horizontal grooves and other conspicuous lines 1) In any bay or any 20' of length: ¼" 2) Entire length: ½"
 3. Variation of wall lines from established position a. In any bay or any 20' of length: ½" b. Entire length: 1"
- F:\WPDATA\LFMSDD\WWTF\Project Manual\Div 3\03100.DOC 03100-1 Original Date of Issue: April 20, 2010
4. Variation of formed surfaces from true plane a. Surfaces exposed to view: 1/240 of span between structural members
 5. Refer to ACI 301 Table 4.3.1 for additional requirements

C. References

1. Except as modified or supplemented herein all concrete formwork shall meet the requirements of the following standard specifications. Pertinent portions of the standards are included herein; refer to standards for detailed requirements:
 - a. American Concrete Institute Standards (ACI) 1) 301-99: Specifications for Structural Concrete for Buildings, Section 2, Formwork 2) 347-01: Recommended Practice for Concrete Formwork
 - b. AASHTO Standard Specifications for Highway Bridges

1.3 SUBMITTALS**A. Refer to Section 013300****PART 2 - PRODUCTS****2.1 GENERAL**

A. Where "Smooth Form Finish" or "Grout Cleaned Finish" is specified, use:

1. Prefabricated plywood or panel forms
2. Job-built plywood forms
3. Forms lined with plywood or fiberboard

B. Where "Rough Form Finish" is specified Steel or unlined wooden forms may be used.

C. All forms are to be of approved design for the purpose intended. Contractor shall provide all form material required.

2.2 FORM MATERIALS

A. Form Sealer to be product specifically manufactured for this purpose and application shall be in strict conformance with manufacturer's specifications, instructions, and recommendations for use.

B. Steel forms:

1. Symons "Steel-Ply" b. Simplex "Industrial Steel Frame Forms"
2. Universal "Uniform"
3. Or equivalent

C. Plywood:

1. Product Standard PSI
2. Waterproof, resin-bonded exterior type, Douglas Fir, Grade B-B

D. Lumber:

1. Straight
2. Uniform width and thickness F:\WPDATA\LFMSDD\WWTF\Project Manual\Div 3\03100.DOC 03100-2 Original Date of Issue: April 20, 2010
3. Free from knots, offsets, holes, dents and other surface defects

- E. Special formwork:
1. "Paper Formed Void"
 - a. Wall Void and Slab Void; Sure Void Products, Inc.
 2. Use void sizes indicated
- F. Accessories
1. Form ties: Approved design, adjustable length, free of devices that will leave hole or depression larger than 7/8" in diameter. Form ties shall be such that when forms are removed there is no metal within 1" of the finished surface. Do not use wire ties with wood spreaders.
 - a. Commercially manufactured permanently embedded type
 - b. Removable ends
 1. Permanently embedded portion terminates not less than ¾" from face of concrete
 - c. Provide water seal washers located on permanently embedded portions of the ties at approximate center of the wall
 2. Joints:
 - a. Slab keyed joints may be formed using 24-gauge galvanized screed key joints of indicated slab depth and steel stake support at 24" maximum centers.
 3. Form Coating
 - a. Approved non-staining, chemical release agent that will not damage the concrete surface
 - b. For exposed surfaces not in contact with earth backfill:
 1. Protex Industries "Pro-Cote"
 2. Symons Corp. "Magic Kote"
 3. L & M "Debond"
 4. Or equivalent
 4. Chamfer Strips
 - a. Clear white pine
 - b. Planed surface against concrete

PART 3 - EXECUTION

3.1 Erection

A. Forms

1. Forms shall conform to shape, lines, dimensions indicated substantial and sufficiently tight to prevent leakage of mortar.
2. Brace or tie forms to maintain desired position, shape, and alignment during and after concrete placement.
3. Where top of a wall will be exposed to weathering, the top of the forms on at least one side shall be brought to true line and grade.
 - a. At other locations forms for concrete which is to be finished to a specified elevation, slope, or contour shall be brought to true line and grade or a wooden guide strip provided at the proper elevation so the top surface can be finished with a screed or template.
4. At horizontal construction joints in walls, forms on one side shall not extend more than 2' above the joint.
5. Provide temporary openings at the bottom of column and wall forms and at other locations where necessary to facilitate cleaning and inspection.
6. Forms for exposed surfaces
 - a. Laid out in a regular and uniform pattern
 - b. Long dimension of panels vertical
 - c. All joints aligned
 - d. Produce finished surfaces free from offsets, ridges, waves, and concave and convex areas
 - e. Uniformly space and align form ties in horizontal and vertical rows.
7. Where concrete is placed against rock
 - a. Remove all loose pieces of rock
 - b. Clean exposed surface with a high-pressure hose
8. Earth cuts shall not be used as forms for vertical surfaces
9. Assemble and place void form in accordance with manufacturer's printed instructions. If void form is wrapped with polyethylene, the polyethylene shall be removed from sides of the form void before backfilling. Not allowed to wrap void form below slabs.
10. Perform all forming required for work of other trades and do all cutting/repairing required to permit such installation.
11. Carefully examine the drawings and specifications and consult with other trades as required relative to provisions for openings, chases, and other items in the forms.

PART 3 - EXECUTION

3.1 Erection

B. Edges and Corners

1. Provide approved moldings and bevels to produce a 3/4" chamfer on all exposed projecting corners unless otherwise noted on the drawings

C. Preparation of Form Surfaces

1. Remove all mortar or grout from previous concrete and all other foreign material from form surfaces
2. Coat form surfaces with approved coating material before either the reinforcing steel or concrete is placed
3. Do not allow form coating to a. Stand in puddles in the forms or b. Come in contact with reinforcing steel or adjacent hardened concrete against which fresh concrete is to be placed

3.2 Form Removal

- A. Wall forms shall not be removed in less than (2) days after pouring concrete unless prior approval has been made by the General Contractor or Owner. Do not remove or disturb until:
1. The concrete has attained sufficient strength to safely support all dead and live loads
 2. Adequate bracing is provided
- B. Take care in form removal to prevent surface gouging, corner or edge breakage, and other damage to the concrete.
- C. Retain shoring in place and reinforce as necessary to carry any:
1. Construction equipment
 2. Materials
 3. Other loads in excess of cured strength
- D. Notify General Contractor or Owner after forms have been removed in order that an inspection of the surfaces can be made prior to pointing and patching in done.
- E. Flush all holes from spreader bars etc. using water then solidly pack with cement grout. Grout shall be (1) part portland cement to (2) parts sand. Apply grout immediately after removal of forms.

CONCRETE ANCHORING

PART 1 - GENERAL

1.1 SUMMARY

A. Section Includes:

1. Requirements pertaining to post-installed steel anchors and steel reinforcement.
Anchoring is required to transmit structural loads.

B. Related Sections:

1. Division 01: Administrative, procedural, and temporary work requirements.
2. Concrete Reinforcing: Section 03 2000
3. Cast-in-Place Concrete: Section 03 3000
4. Division 04: Masonry

1.2 REFERENCES

A. American Concrete Institute (ACI)

1. ACI 318 – Building Code Requirements for Structural Concrete.
2. ACI 355.2 – Standard for Evaluating the Performance of Post-Installed Mechanical Anchors in Concrete.

B. International Code Council (ICC)

1. ICC-ES AC70 – Acceptance Criteria for Fasteners Power-Driven into Concrete, Steel & Masonry Elements
2. ICC-ES AC106 – Acceptance Criteria for Predrilled Fasteners (Screw Anchors) in Concrete or Masonry Elements
3. ICC-ES AC193 – Acceptance Criteria for Mechanical Anchors in Concrete Elements
4. ICC-ES AC308 – Acceptance Criteria for Post-Installed Adhesive Anchors in Concrete Elements

C. ASTM International (ASTM):

1. A36 - Standard Specification for Carbon Structural Steel.
2. A153 – Standard Specification for Zinc Coating (Hot-Dip) on Iron and Steel Hardware.
3. A193 – Standard Specification for Alloy-Steel and Stainless Steel Bolting Materials for High Temperature Service
4. A307 - Standard Specification for Low-Carbon Steel Externally and Internally Threaded Standard Fasteners.
5. A615 – Standard Specification for Deformed and Plain Billet-Steel Bars for Concrete Reinforcement.
6. B633 – Standard Specification for Electrodeposited Coatings of Zinc on Iron and Steel.
7. B695 – Standard Specification for Coatings of Zinc Mechanically Deposited on Iron and Steel.
8. C881 – Standard Specification Epoxy-Resin-Based Bonding Systems for Concrete.
9. E488 – Standard Test Methods for Strength of Anchors in Concrete and Masonry Elements
10. E1512 – Standard Test Methods for Testing Bond Performance of Bonded Anchors
11. F593 – Standard Specification for Stainless Steel Bolts, Hex Cap Screws, and Studs

1.3 SUBMITTALS

A. Submittals for Review:

1. If alternate anchors and adhesive are desired, submit to Structural Engineer for approval. See Part 2, "Products" within this specification section for additional requirements.

1.4 QUALITY ASSURANCE

- A. Installer of anchoring is required to follow all installation specifications and instructions from manufacturer.

1.5 DELIVERY, STORAGE AND HANDLING

- A. Deliver products to job site in manufacturer's or distributor's packaging undamaged, complete with installation instructions.
- B. Protect and handle materials in accordance with manufacturer's recommendations to prevent damage or deterioration.

PART 2 - PRODUCTS

2.1 MATERIAL CRITERIA

A. Expansion Anchors:

1. Structural Concrete Wedge Anchors: Anchors used to transmit load between structural elements shall be designed in accordance with ACI 318 Appendix D, which requires post-installed mechanical anchors to be qualified according to ACI 355.2. Such anchors shall be an imperial sized, threaded stud with an integral cone expander and three-segment expansion clip. The stud shall be manufactured from carbon steel and the expansion clip shall have 2 undercutting embossments per segment and be manufactured from 316 stainless steel. Carbon steel anchors shall have an electroplated zinc finish in accordance with ASTM B633, Class SC1, Type I. Anchors shall be tested and qualified for performance in cracked and uncracked concrete in accordance with ACI 355.2 and ICC-ES AC193 for all mandatory tests.
 - a. Unless otherwise noted on the Structural Drawings, structural concrete wedge anchors shall be "Strong-Bolt" wedge anchors by Simpson Strong-Tie.

B. Adhesive Anchors:

1. An adhesive anchor shall consist of an insert and an adhesive formula. Inserts shall meet the requirements of ASTM A307, A36, A193 Grade B7, or F1554 for threaded rods or ASTM A615 or A706 for rebar. For exterior exposure the threaded insert shall be stainless steel or zinc coated carbon steel. The zinc coating shall be either hot-dipped in accordance with ASTM A153 Class C or D; mechanically deposited in accordance with ASTM B695, Class 65, Type I; or demonstrated through tests to be equivalent to the coatings previously described.

2. Structural Concrete Epoxy Adhesives: Anchors used to transmit load between structural elements shall be designed in accordance with ACI 318 Appendix D as amended by the specific design provisions of ICC-ES AC308. Adhesives shall be a cartridge type, two-component, high solids epoxy based system dispensed and mixed through a static mixing nozzle supplied by the manufacturer. The adhesive shall meet the minimum requirements of ASTM C-881 Type I and IV, Grade 3, Class C. Acceptable installation and performance temperature ranges shall be verified with manufacturer's literature prior to installation. Epoxy adhesives shall have been tested and qualified for use in cracked and uncracked concrete in accordance with ICC-ES AC308 for all mandatory tests.

a. Unless otherwise noted in the Structural Drawings, structural concrete epoxy adhesives shall be "SET-XP" by Simpson Strong-Tie.

3. Structural Concrete Acrylic Adhesives: Anchors used to transmit load between structural elements shall be designed in accordance with ACI 318 Appendix D as amended by the specific design provisions of ICC-ES AC308. Adhesives shall be a cartridge type, two-component, high solids acrylic- based system dispensed and mixed through a static mixing nozzle supplied by the manufacturer. Acceptable installation and performance temperature ranges shall be verified with manufacturer's literature prior to installation. Acrylic adhesives shall have been tested and qualified for use in cracked and uncracked concrete in accordance with ICC-ES AC308 for all mandatory tests.

a. Unless otherwise noted in the Structural Drawings, structural concrete acrylic adhesives shall be "AT-XP" by Simpson Strong-Tie.

C. Screw Anchors:

1. Structural Concrete Screw Anchors: Anchors used to transmit load between structural elements shall be designed in accordance with ACI 318 Appendix D as amended by the specific design provisions of ICCES AC193. Anchors shall be manufactured from carbon steel which is subsequently heat-treated. Anchors shall be zinc-plated in accordance with ASTM B633, Class SC1, Type 1. Anchors shall have been tested and qualified for use in cracked and uncracked concrete in accordance with ICC-ES AC193 for all mandatory tests.

a. Unless otherwise noted in the Structural Drawings, structural concrete screw anchors shall be "Titen HD" anchors by Simpson Strong-Tie.

2. Structural Masonry Screw Anchors: Anchors shall have a 360-degree contact with the base material and shall not require oversized or undersized holes for installation. Anchors shall be manufactured from carbon steel which is subsequently heat-treated. Anchors shall be zinc-plated in accordance with ASTM B633, Class SC1, Type 1.

Anchors shall have an evaluation report issued by the ICC-ES and have been tested in accordance with ICC-ES AC106.

a. Unless otherwise noted in the Structural Drawings, structural masonry screw anchors shall be "Titen HD" anchors by Simpson Strong-Tie.

b. Masonry anchors placed in hollow cells of masonry are not covered under this section of the specification. See Structural Drawings for requirements.

D. Powder Actuated Fasteners:

1. Fasteners shall be drive pin and threaded stud types, as applicable for each condition. Fasteners shall be manufactured from AISI 1060 to 1065 steel austempered to a Rockwell "C" Hardness of 51-56, and have a mechanically galvanized finish. Fasteners to have a minimum bending yield strength of 90 ksi. Fasteners shall have an evaluation report issued by ICC-ES and have been tested in accordance with ICC-ES AC70.

E. Anchor Sizes:

1. The anchor sizes (nominal diameter and embedment depth) shall be as indicated on the Structural Drawings.

F. Alternate Anchor and Adhesive Submittals:

1. Post installed anchors and adhesives as noted on the Structural Drawings have been specified by the Structural Engineer to carry the required design loads. If alternate anchors and adhesive are desired by the contractor, a formal submittal for approval must be made to the Structural Engineer prior to ordering of material. All alternate anchors and adhesives are required to follow the specifications listed in this specification section. The contractor is responsible for the cost of additional engineering and detailing that may be required to approve the alternate anchors and adhesive.

PART 3 – EXECUTION

3.1 INSTALLATION:

- A. Install all anchors and adhesive per manufacturer's specifications.
- B. Prepare substrate surface per manufacturer's specifications.
Ensure that substrate material is of proper temperature prior to placement of adhesive and during curing time.
- C. Where manufacturer recommends use of special tools for installation of anchors, such tools shall be used.
- D. Where holes are drilled in concrete or masonry, holes shall be accurately and squarely drilled, and the holes shall be cleaned in accordance with the manufacturer's recommendations.
- E. Install adhesive and provide curing temperature per manufacturer's specifications.

3.2 FIELD QUALITY CONTROL

- A. Testing and Inspection Services:
 - 1. See Structural Drawings for Special Inspection Requirements.
 - 2. Independent Testing Agency to submit test reports to Architect/Engineer.

PART 1 - GENERAL

1.1 SUMMARY

A. Section Includes:

1. Reinforcing bars
2. Accessories for cast-in-place concrete.

B. Related Sections:

1. Division 01: Administrative, procedural, and temporary work requirements.
2. Section 03 30 00: Cast-in-Place Concrete

1.2 REFERENCES

A. American Concrete Institute (ACI)

1. 301 - Specifications for Structural Concrete for Buildings.
2. 315 – Details and Detailing of Concrete Reinforcement
3. 318 – Building Code Requirements for Structural Concrete
4. SP-66 – ACI Detailing Manual

B. ASTM International (ASTM):

1. A185 - Standard Specification for Welded Steel Wire Reinforcement, Plain, for Concrete.
2. A615 - Standard Specification for Deformed and Plain Billet-Steel Bars for Concrete Reinforcement.

C. Concrete Reinforcing Steel Institute (CRSI):

1. Manual of Practice.
2. Publication 63 - Recommended Practice for Placing Reinforcing Bars.
3. Publication 65 - Recommended Practice for Placing Bar Supports, Specifications and Nomenclature.

1.3 SUBMITTALS

A. Submittals for Review:

1. Shop Drawings:
 - a. Include bar sizes, spacing, concrete clear distances, lap length, locations, and quantities of reinforcing bars, wire fabric, and accessories.
 - b. Provide bending and cutting schedules.
 - c. Show complete layout plan for each layer of reinforcing.

1.4 DELIVERY, STORAGE AND HANDLING

- A. Deliver reinforcing to project site in bundles marked with tags indicating bar size, length, and mark.
- B. Store reinforcing above ground in dry, well drained area; protect from corrosion.

PART 2 - PRODUCTS

2.1 MATERIALS

A. Reinforcing Bars:

1. ASTM A615, deformed billet steel, Grade 60.
2. Finish: Plain.

2.2 ACCESSORIES

A. Spacers, Chairs, Bolsters, and Bar Supports:

1. Sized and shaped for strength and support of reinforcement during concrete placement.
2. Galvanized or plastic coated steel for surfaces exposed to weather.

B. Tie Wire: Annealed, minimum 16 gage.

C. Joint Dowel Bars: ASTM A615/A 615M, Grade 60, plain steel bars cut bars true to length with ends square, free of burrs.

2.3 FABRICATION

A. Fabricate in accordance with ACI 301, CRSI and MCP Manuals.

B. Bend bars cold; do not heat or bend by makeshift methods. Discard damaged bars.

C. Welding: AWS D1.4. Welding of reinforcement is permitted only with the specific approval of the Structural Engineer.

D. Fabrication Tolerances:

1. Sheared length: Plus or minus 1/2 inch.
2. Bends in stirrups and ties: Plus or minus 1/2 inch.
3. All other bends: Plus or minus 1/2 inch.

PART 3 – EXECUTION

3.1 PREPARATION

- A. Before placing in work, thoroughly clean reinforcing of loose rust, mill scale, dirt, oil, and other materials that could reduce bonding.
- B. Inspect reinforcing left protruding for future bonding or following delay in work, and clean if necessary.

3.2 INSTALLATION

- A. Install reinforcing in accordance with ACI 301, and CRSI Manual and Publications 63 and 65.
- B. Accurately position reinforcing; securely tie at intersections. Do not deviate from the required position.
- C. Do not displace or damage vapor retarder.
- D. Locate splices not indicated on Drawings at points of minimum stress.
- E. Lap and provide hooks per lap schedule on Structural Drawings.
- F. Doweled Joints: Install dowel bars and support assemblies at joints where indicated. Lubricate or asphalt coat one-half of dowel length to prevent bonding to one side of joint.

3.3 FIELD QUALITY CONTROL

- A. See Structural Drawings for Special Inspection requirements. Independent Testing Agency to submit test reports to Architect/Engineer.

3.4 DEFECTIVE CONCRETE

- A. Modify or replace reinforcing not conforming to details and specifications as directed by the Architect/Engineer.

PART 1 - GENERAL

1.1 SUMMARY

A. Section Includes:

1. Cast-in-place concrete for piers, foundations, slabs on grade, and supported slabs.
2. Bases for flagpoles and lighting fixtures.

B. Related Sections:

1. Division 01: Administrative, procedural, and temporary work requirements.
2. Section 03 2000: Concrete Reinforcing

1.2 REFERENCES

A. American Concrete Institute (ACI):

1. 301 - Structural Concrete for Buildings.
2. 305R - Hot Weather Concreting.
3. 306R - Cold Weather Concreting.
4. 308 - Standard Practice for Curing Concrete.
5. 318 - Building Code Requirements for Structural Concrete.
6. 117 – Specifications for Tolerances of Concrete Construction
7. 308R – Guide to Curing Concrete
8. 304R – Guide for Measuring, Mixing, Transporting, and Placing Concrete
9. 302.1R – Guide for Concrete Floor and Slab Construction.

B. Concrete Reinforcing Steel Institute (CRSI):

1. CRSI Manual of Standard Practice.

C. ASTM International (ASTM):

1. C31 - Standard Test Method for Method of Making and Curing Concrete Test Specimens in the Field.
2. C33 - Standard Specification for Concrete Aggregates.
3. C39 - Standard Test Method for Test Method for Compressive Strength of Cylindrical Concrete Specimens.
4. C94 - Standard Specification for Ready-Mixed Concrete.
5. C143 - Standard Test Method for Slump of Portland Cement Concrete.
6. C150 - Standard Specification for Portland Cement.
7. C171 - Standard Specification for Sheet Materials for Curing Concrete.
8. C172 - Standard Test Method for Method of Sampling Freshly Mixed Concrete.
9. C231 - Standard Test Method for Air Content of Freshly Mixed Concrete by the Pressure Method.
10. C260 - Standard Specification for Air-Entraining Admixtures for Concrete.
11. C309 - Standard Specification for Liquid Membrane-Forming Compounds for Curing Concrete.
12. C330 - Standard Specification for Lightweight Aggregates for Structural Concrete.
13. C494 - Standard Specification for Chemical Admixtures for Concrete.
14. C618 - Standard Specification for Fly Ash and Raw or Calcined Natural Pozzolans for Use as a Mineral Admixture in Portland Cement Concrete.
15. C1116 - Standard Specification for Fiber-Reinforced Concrete and Shotcrete.
16. D1752 - Standard Specification for Preformed Sponge Rubber and Cork Expansion Joint Fillers for Concrete Paving and Structural Construction.

1.3 SUBMITTALS

A. Concrete Mix Designs Submittals for Review Include:

1. Proportions of cement, fine and coarse aggregates, fibrous reinforcing, and water.
2. Combined aggregate gradation.
3. Aggregate specific gravities and gradations.
4. Water/cement ratio, design strength, slump, and air content.
5. Type of cement and aggregates.
6. Air dry density and split cylinder ratio for lightweight concrete.
7. Type and proportion of admixtures.
8. Special requirements for pumping.
9. Range of ambient temperature and humidity for which design is valid.
10. Special characteristics of mix requiring precautions in mixing, placing, or finishing techniques to achieve finished product.
11. Manufacturers specifications for Vapor retarder
12. Manufacturers specifications for Waterstop
13. Manufacturers specifications for curing compound
14. Manufacturers specifications for evaporation retarder
15. Manufacturers specifications for moisture retaining cover
16. Manufacturers specifications for expansion joint filler strips
17. Manufacturers specifications for Semi rigid Joint Filler

1.4 QUALITY ASSURANCE

A. Concrete Mix Design: In accordance with ACI 301, Method 1 or 2.

1.5 DELIVERY, STORAGE AND HANDLING

A. Mix and deliver concrete to project ready mixed in accordance with ASTM C94.

B. Schedule delivery so that pours will not be interrupted for over 15 minutes.

C. Place concrete on site within 90 minutes after proportioning materials at batch plant.

D. Waterstops: Store waterstops under cover to protect from moisture, sunlight, dirt, oil and other contaminants.

1.6 PROJECT CONDITIONS

A. Cold Weather Placement - Protect concrete work from physical damage or reduced strength that could be caused by frost, freezing actions, or low temperatures. Comply with ACI 306R and following requirements:

1. Air temperature at or expected to fall below 40 degrees F, uniformly heat water and aggregates before mixing to obtain a concrete mixture temperature of not less than 50 degrees F and not more than 80 degrees F at point of placement.
2. Do not use frozen materials or materials containing ice or snow. Do not place concrete on frozen subgrade or on subgrade containing frozen materials.
3. Do not use calcium chloride, salt, and other materials containing antifreeze agents or chemical accelerators unless otherwise accepted in mix designs.

B. Hot Weather Placement - Place concrete in accordance with ACI 305R and following requirements:

1. Cool ingredients before mixing to maintain concrete temperature at time of placement below 90 degrees

F. Use chilled mixing water or chopped ice if water equivalent of ice is calculated in total amount of mixing water.

1. If required, cover reinforcing steel with water soaked burlap so that steel temperature will not exceed ambient air temperature.
2. Fog spray forms, reinforcing steel, and subgrade just before concrete is placed.
3. Use water-reducing retarding admixture when required by high temperatures, low humidity, or other adverse placing conditions.
4. When Air Temperature is above 90 degrees F, reduce mixing and delivery time to 60 minutes.

PART 2 - PRODUCTS

2.1 MANUFACTURERS

A. Acceptable Manufacturers - Concrete Chemicals:

1. Burke by Edoco.
2. Conspec Marketing and Manufacturing.
3. Dayton/Richmond.
4. BASF Admixtures, Inc.
5. W. R. Meadows, Inc.
6. Nox-Crete Products Group.
7. Xypex Chemical Corporation
8. Non-listed as approved by submittal.

B. Substitutions: Under provisions of Division 01.

2.2 MATERIALS

A. Portland Cement: ASTM C150, Type I or III, gray color.

B. Aggregates:

1. Fine: ASTM C33, clean, hard, durable, uncoated natural sand, free from silt, loam, and clay.
2. Coarse: ASTM C33, clean, hard, durable, uncoated crushed stone, maximum size No. 467 Table No. 2.

C. Fly Ash: ASTM C618, maximum 2 percent loss on ignition.

D. All concrete to be plant redi-mix type. Site mixed concrete is not acceptable.

Cement used in all exposed concrete shall be of a single brand to eliminate color variation.

E. Water: Clean and potable.

2.3 ACCESSORIES

A. Admixtures:

1. Water reducing or water reducing/set retarding: ASTM C494, Type A or D.
2. Air entraining: ASTM C260.

B. Waterstop: Flexible PVC waterstop CE CRD-C 572, for embedding into concrete to prevent passage of fluids through joints. Factory fabricate corners, intersections and directional changes. Profile to be flat dumb-bell without center bulb.

C. Plastic Vapor Retarder: ASTM E 1745, Class C, **or polyethylene sheet, ASTM D 4397, not less than 10 mils (0.25 mm) thick.** Include manufacturer's recommended adhesive or pressure-sensitive joint tape.

D. Expansion Joint Filler: ASTM D1752, asphaltic-saturated cellulosic fiber type.

E. Bonding Agent: Two component modified epoxy resin.

F. Evaporation retarder: Waterborne monomolecular film forming, manufactured for application to fresh concrete

G. Curing Compound: ASTM C309.

H. Curing Paper: ASTM C171, waterproof paper or polyethylene film.

I. Semi Rigid Joint Filler: Two component, semi-rigid 100 percent solids epoxy resin with a type A shore durometer hardness of 80, per ASTM D 2240.

J. Dovetail Anchor Slots: Hot-dip galvanized steel sheet, not less than 0.0336 inch thick, with bent tab anchors.

Temporarily fill or cover face opening of slots to prevent intrusion of concrete debris.

2.4 MIXES

A. Proportions: In accordance with ACI 301.

B. Design concrete to yield characteristics indicated on Drawings.

C. Air Entrained Concrete: Provide air entraining admixture to produce 6 +/- 1.5% percent air by volume of concrete.

D. Use accelerating admixture in cold weather only when approved by Architect/Engineer. Use of admixtures will not reduce cold weather placement requirements.

E. Fly Ash Content ASTM C618: Minimum 30 percent by weight of cementations material in mix if seasonal curing conditions permit.

PART 3 - EXECUTION**3.1 PREPARATION**

A. Notify Architect and Testing Laboratory minimum 24 hours prior to placing concrete.

B. Construct formwork to ACI 301 and maintain tolerances and surface irregularities with ACI 347R.

C. Accurately position anchor bolts, sleeves, conduit, inserts, and accessories. Do not cut reinforcing steel to facilitate installation of inserts or accessories.

D. Remove water and debris from forms and excavations.

E. Close openings left in forms for cleaning and inspection.

F. Prepare previously placed [and existing] concrete surfaces by cleaning with steel wire brush and applying bonding agent in accordance with manufacturer's instructions.

G. Where new concrete is doweled to existing, drill holes in existing concrete, insert steel dowels, and pack holes solid with non shrink grout. See Structural Drawings for detailing of connection at existing.

3.2 PLACEMENT OF CONCRETE

A. Place concrete in accordance with ACI 301 and ACI 318.

B. Ensure reinforcement, inserts, and embedded parts are not disturbed during concrete placement.

C. Deposit concrete as nearly as possible in its final position to minimize handling and flowing.

D. Place concrete continuously between predetermined expansion, control, and construction joints.

E. Do not place partially hardened, contaminated, or re-tempered concrete.

F. Do not allow concrete to free fall over 6 feet; provide tremies, chutes, or other means of conveyance.

G. Consolidate concrete with mechanical vibrating equipment. Hand compact in corners and angles of forms.

H. Screed slabs level, to flatness and levelness indicated on structural drawings.

I. Install construction, isolation and contraction joints where indicated on the Drawings.

J. Provide adequate wall bracing for back filling work. Any walls damaged or that move due to inadequate bracing during backfilling shall be replaced by concrete contractor.

K. Saw cut joints per ACI requirements.

L. Dowel joints where indicated

3.3 VAPOR RETARDER

- A. Plastic Vapor Retarders: Place, protect, and repair vapor retarders according to ASTM E 1643 and manufacturer's written instructions.
1. Lap joints 6 inches (150 mm) and seal with manufacturer's recommended tape.

3.4 WATERSTOPS

- A. Flexible Water stops: Install in construction joints and at other joints indicated to form a continuous diaphragm. Install in longest lengths practicable. Support and protect exposed water stops during progress of the Work. Field fabricate joints in water stops according to manufacturer's written instructions.

3.5 CONSTRUCTION JOINTS

- A. All walls shall have construction joints as indicated and or not over 60' in any horizontal direction where concrete is exposed to the elements. Joints shall be keyed and reinforcing steel carried through joints or laps. Locate joints to least impair strength and appearance. No horizontal joints will be permitted in the walls, floors or beams.
- B. Slabs shall be divided by contraction or construction joints where directed, but not over (36) times the slab thickness. Saw cuts shall be at least 1/4 of the slab thickness deep.
- C. Make provisions for jointing successive pours either through use of a "V" groove at the vertical surface or use of dowels as shown on the drawings.
- D. Reinforcing shall be thoroughly cleaned beyond the joint before the next pour is made.
- E. Rate and method of placing concrete arrangement of construction joint bulkheads shall be such that concrete between construction joints shall be placed in a continuous pour.
- F. Sawed contraction joints are to be made as soon as possible after the concrete hardens. The concrete is hard enough when the blade does not dislodge aggregates and the edges of the cut do not ravel. **Confirm location of these cuts with the General Contractor or Owner prior to commencement to avoid placement where sheet goods flooring is to be installed.**

3.6 PLACEMENT OF GROUT

- A. Remove loose and foreign matter from concrete; lightly roughen bonding surface.
- B. Just prior to grouting, thoroughly wet concrete surfaces; remove excess water.
- C. Mix grout in accordance with manufacturer's instructions. Do not re-temper.
- D. Place grout continuously, by most practical means; avoid entrapped air. Do not vibrate grout.

3.7 PROTECTION

- A. Immediately after placement, protect concrete from premature drying, excessively hot or cold temperatures, & mechanical injury.
- B. Maintain concrete with minimal moisture loss at relatively constant temperature for period necessary for hydration of cement and hardening of concrete.
- C. Provide artificial heat to maintain temperature of concrete above minimum specified temperature for duration of curing period.
- D. Keep forms sufficiently wet to prevent cracking of concrete or loosening of form joints.
- E. Patching: Fill tie rod holes solidly with mortar. Fill holes passing through wall from inside face using a device that will force mortar through to the outside to ensure complete filling. Strike off excess mortar.
- F. Contractor shall be responsible to protect materials and devices protruding through the floor during placement. If there is an incident of a plumbing pipe etc. being broken or damaged, the contractor shall immediately notify the General Contractor or Owner. If circumstances will not allow for this then the contractor is to box off the immediate area of the damage so repairs can be made at a later date. **DO NOT POUR OVER OR AROUND BROKEN PIPES!**

3.8 CURING

- A. Cure concrete in accordance with ACI 308:
1. Horizontal surfaces:
 - a. Surfaces to receive additional toppings or setting beds: Use curing paper method.
 - b. Other surfaces: Use either curing paper or curing compound method.
 2. Vertical surfaces: Use either wet curing or curing compound method.
- B. Curing Compound Method:
1. Spray compound on surfaces in two coats, applying second at right angle to first, at minimum rate recommended by manufacturer.
 2. Restrict traffic on surfaces during curing.
- C. Curing Paper Method:
1. Spread curing paper over surfaces, lapping ends and sides minimum 4 inches; maintain in place by use of weights.
 2. Remove paper after curing.
- D. Wet Curing Method: Spray water over surfaces and maintain wet for 7 days.

3.9 CONCRETE WALKS

- A. Concrete walks must conform to all state and local code requirements
- B. Base material to be 6" washed gravel, clean sand or crushed rock, compacted.
- C. Concrete walks shall be 4" thick with the exception of any curb-faced walks shown on the drawings. **All walks are to crown at the center or slope uniformly to sides as indicated on the drawings OR as directed by the General Contractor or Owner.**
- D. Wherever necessary contractor shall install for sleeving for other contractors as directed by the General Contractor or Owner. Materials for sleeving are provided by others. Confirm necessity of sleeving prior to placement of concrete.
- E. Broom finish is to be applied.
- F. Ramping is to be installed as shown on the drawings. State and Local codes shall be followed and override drawings. If there is a difference, contractor shall notify General Contractor or Architect prior to placement of forms.

3.10 CLEANING

- A. Remove efflorescence, stains, oil, grease, and foreign materials from exposed surfaces.
- B. At completion carefully clean all concrete surfaces taking care not to damage other portions of work.
- C. Remove all rubbish and debris from site as it is accumulated and excess material as soon as work is completed.

3.11 FIELD QUALITY CONTROL

- A. Testing and Inspection Services: Perform work per ACI 301 and ACI 318
 - 1. Certify each delivery ticket.
 - 2. Record time at which concrete was discharged from truck.
 - 3. Monitor and record amount of water and water reducing admixture added to concrete at project site.
 - 4. Determine ambient temperature and temperature of concrete sample for each set of test cylinders.
 - 5. Test cylinders:
 - a. Make test cylinders in accordance with ASTM C172; one set of 3 cylinders for each 50 cubic yards or fraction thereof placed in any one day, for each different class of concrete.
 - b. Mold and cure cylinders in accordance with ASTM C31; test cylinders in accordance with ASTM C39; one at 7 days and two at 28 days.
 - 6. Slump tests: Make slump tests at beginning of each day's placement and for each set of test cylinders in accordance with ASTM C143.
 - 7. Air content: Determine total air content of air entrained concrete for each strength test in accordance with ASTM C231.
- B. See Structural Drawings for Special Inspection requirements that are not included within this specification section. Independent Testing Agency to submit test reports to Architect/Engineer.

3.10 DEFECTIVE CONCRETE

- A. Modify or replace concrete not conforming to details and specifications as directed by the Architect/Engineer.

1. PART 1 GENERAL

- A. Provide all labor and materials, including equipment and supervision for the installation of the lightweight concrete floor fill where indicated.
- B. Installation shall be under the direct supervision of an applicator that is certified by the manufacturer.
- C. Contractor shall provide a finished product surface smooth and level ready for the installation of floor coverings. Rough or rippled areas will be rejected. Contractor shall thoroughly inspect all areas in the company of the General Contractor or Owner for quality. Written acceptance or rejection shall be provided. Rejected areas shall be corrected at no additional cost to the owner.

PART 2 - PRODUCTS

2.1 MANUFACTURERS

- A. Acceptable Manufacturers: Gypsum Underlayment:
 - 1. ARDEX Engineered Cements: www.ardexamericas.com.
 - 2. Dependable Chemical Co., Inc: www.floorprep.com.
 - 3. Hacker Industries, Inc: www.hackerindustries.com.
 - 4. Maxxon Corporation: www.maxxon.com.
- B. Substitutions: Under provisions of Division 01. See Section 01 6000 - Product Requirements.

2.2 MATERIALS

- A. Materials: Gypsum-based Underlayment: Gypsum-based mix, that when mixed with water in accordance with manufacturer's directions will provide self-leveling underlayment with the following properties:
 - 1. Compressive Strength: Minimum 2500 psi, tested per ASTM C 472.
 - 2. Density: Maximum 115 lb/cu ft.
 - 3. Final Set Time: 1 to 2 hours, maximum.
 - 4. Thickness: ¾ inch to maximum of 3-1/2 inch.
 - 5. Surface Burning Characteristics: flame spread/smoke developed index of 0/0 in accordance with ASTM E 84.
- B. Water: Water shall be potable and free from deleterious amount of acid, alkali, and organic materials which would adversely affect the setting time or the strength of the concrete; not detrimental to underlayment mix materials.
- C. Primer: manufacturer's recommended type.
- D. Joint and Crack Filler: Latex based filler, as recommended by manufacturer.

PART 3 - EXECUTION

3.1 CLEANING

- A. Floor area to be poured shall be broom cleaned. All blocking shall be in place and holes filled. Area must be free from other trades.
- B. Follow manufacturer's recommendations relative to mechanical rough-ins, interior finished, etc. Coordinate with all trades for timing of installation.
- C. Before, during and after installation, building interior shall be enclosed and maintained at a temperature above 50° F. until structure and subfloor temperatures are stabilized.
- D. Provide continuous heat and adequate ventilation to rapidly remove moisture from the area until underlayment is dry. Provide mechanical ventilation if necessary.
Under the above conditions, 5 - 7 days is usually adequate drying time.
- E. To minimize damage to installed underlayment and to complete fire and sound seals, pouring should be scheduled after the installation of drywall. During construction, place temporary wood planking over underlayment wherever it will be subjected to heavy wheeled or concentrated loads.
- F. Installer shall be responsible for filling all shrinkage cracks with approved mastic.
- G. Air cure in accordance with manufacturer's instructions.
- H. Contractor shall remove all excess materials and debris from the site upon completion of the work.
- I. All rubbish and debris shall be placed in the dumpster provided.

PART 1 - GENERAL

1.01 RELATED DOCUMENTS

A. Drawings and general provisions of the Contract, including General and Supplementary Conditions and Division 01 Specification Sections, apply to this Section.

1.02 SUMMARY

A. Section Includes:

1. Precast structural concrete.

B. Related Requirements:

1. Section 03 3000 "Cast-in-Place Concrete" for concrete topping and placing connection anchors in concrete.
2. Section 05 5000 "Metal Fabrications" for kickers and other miscellaneous steel shapes.

1.03 DEFINITIONS

A. Design Reference Sample: Sample of approved precast structural concrete color, finish, and texture, preapproved by Architect.

1.04 PREINSTALLATION MEETINGS

A. Preinstallation Conference: Conduct conference at Project site.

1.05 ACTION SUBMITTALS

A. Product Data: For each type of product.

B. Design Mixtures: For each precast concrete mixture. Include compressive strength and, if required, water-absorption tests.

C. Shop Drawings:

1. Include member locations, plans, elevations, dimensions, shapes and sections, openings, support conditions, and types of reinforcement, including special reinforcement.
2. Detail fabrication and installation of precast structural concrete units, including connections at member ends and to adjoining construction.
3. Indicate joints, reveals, drips, chamfers, and extent and location of each surface finish.
4. Indicate separate face and backup mixture locations and thicknesses.
5. Indicate type, size, and length of welded connections by AWS standard symbols.
6. Detail loose and cast-in hardware, lifting and erection inserts, connections, and joints.
7. Indicate locations, tolerances, and details of anchorage devices to be embedded in or attached to structure or other construction.
8. Include and locate openings larger than 10 inches. Where additional structural support is required, include header design.
9. Indicate location of each precast structural concrete unit by same identification mark placed on panel.
10. Indicate relationship of precast structural concrete units to adjacent materials.
11. Indicate locations, dimensions, and details of thin-brick units, including corner units and special shapes, and joint treatment.
12. Indicate locations, dimensions, and details of stone facings, anchors, and joint widths.
13. Indicate estimated camber for precast floor slabs with concrete toppings.
14. Indicate shim sizes and grouting sequence.
15. If design modifications are proposed to meet performance requirements and field conditions, submit design calculations and Shop Drawings. Do not adversely affect the appearance, durability, or strength of units when modifying details or materials and maintain the general design concept.

D. Delegated-Design Submittal: For precast structural concrete indicated to comply with performance requirements and design criteria, including analysis data signed and sealed by the qualified professional engineer responsible for their preparation.

1. Show precast structural concrete unit types, connections, types of reinforcement, including special reinforcement, and concrete cover on reinforcement. Indicate location, type, magnitude, and direction of loads imposed on the building structural frame from precast structural concrete.

1.06 INFORMATIONAL SUBMITTALS

A. Qualification Data: For Installer, fabricator, testing agency.

B. Welding certificates.

C. Material Test Reports: For aggregates, by a qualified testing agency.

D. Preconstruction test reports.

E. Source quality-control reports.

F. Field quality-control and special inspection reports.

034100 - PRECAST STRUCTURAL CONCRETE

1.07 QUALITY ASSURANCE

A. Fabricator Qualifications: A firm that assumes responsibility for engineering precast structural concrete units to comply with performance requirements. Responsibility includes preparation of Shop Drawings and comprehensive engineering analysis by a qualified professional engineer.

1. Designated as a PCI-certified plant as follows:

a. Group C, Category C2 - Prestressed Hollowcore and Repetitively Produced Products, Category C3 - Prestressed Straight Strand Structural Members Category, C4 - Prestressed Deflected Strand Structural Members.

B. Installer Qualifications: A precast concrete erector qualified and designated by PCI's Certificate of Compliance, to erect Category S1 - Simple Structural Systems.

C. Testing Agency Qualifications: Qualified according to ASTM C 1077 and ASTM E 329 for testing indicated.

D. Quality-Control Standard: For manufacturing procedures, testing requirements, and quality-control recommendations for types of units required, comply with PCI MNL 116, "Manual for Quality Control for Plants and Production of Structural Precast Concrete Products."

E. Welding Qualifications: Qualify procedures and personnel according to the following:

1. AWS D1.1/D1.1M, "Structural Welding Code - Steel."
2. AWS D1.4/D1.4M, "Structural Welding Code - Reinforcing Steel."

1.08 COORDINATION

A. Furnish loose connection hardware and anchorage items to be embedded in or attached to other construction before starting that Work. Provide locations, setting diagrams, templates, instructions, and directions, as required, for installation.

1.09 DELIVERY, STORAGE, AND HANDLING

A. Support units during shipment on non-staining shock-absorbing material in same position as during storage.

B. Store units with adequate bracing and protect units to prevent contact with soil, to prevent staining, and to prevent cracking, distortion, warping or other physical damage.

1. Store units with dunnage across full width of each bearing point unless otherwise indicated.
2. Place adequate dunnage of even thickness between each unit.
3. Place stored units so identification marks are clearly visible, and units can be inspected.

C. Handle and transport units in a manner that avoids excessive stresses that cause cracking or damage.

D. Lift and support units only at designated points indicated on Shop Drawings.

PART 2 - PRODUCTS

2.01 MANUFACTURERS

A. Approved Manufacturers

1. Molin Concrete Products
2. Wells Concrete
3. Gage Brothers Concrete Products
4. County Materials Corporation

2.02 PERFORMANCE REQUIREMENTS

A. Delegated Design: Engage a qualified professional engineer, as defined in Section 01 4000 "Quality Requirements," to design precast structural concrete units.

B. Design Standards: Comply with ACI 318 and with design recommendations in PCI MNL 120, "PCI Design Handbook - Precast and Prestressed Concrete," applicable to types of precast structural concrete units indicated.

C. Fire-Resistance Calculations: Where indicated, provide precast structural concrete units whose fire resistance meets prescriptive requirements of authorities having jurisdiction or has been calculated according to ACI 216.1 and PCI MNL 124, "Design for Fire Resistance of Precast Prestressed Concrete," and is acceptable to authorities having jurisdiction.

D. Structural Performance: Precast structural concrete units and connections shall withstand design loads indicated within limits and under conditions indicated.

E. Structural Performance: Provide precast structural concrete units and connections capable of withstanding the design loads as indicated on structural drawings within limits and under conditions indicated:

1. Design precast structural concrete framing system and connections to maintain clearances at openings, to allow for fabrication and construction tolerances, to accommodate live-load deflection, shrinkage and creep of primary building structure, and other building movements. Maintain precast structural concrete deflections within limits of ACI 318.
2. Fire-Resistance Rating: Select material and minimum thicknesses to provide indicated fire rating.

2.03 MOLD MATERIALS

- A. Molds: Rigid, dimensionally stable, non-absorptive material, warp and buckle free, that provides continuous precast concrete surfaces within fabrication tolerances indicated; nonreactive with concrete and suitable for producing required finishes.
1. Mold-Release Agent: Commercially produced form-release agent that does not bond with, stain, or adversely affect precast concrete surfaces and does not impair subsequent surface or joint treatments of precast concrete.
- B. Form Liners: Furnish with manufacturer's recommended form-release agent that does not bond with, stain, or adversely affect precast concrete surfaces and does not impair subsequent surface or joint treatments of precast concrete.
- C. Surface Retarder: Chemical set retarder, capable of temporarily delaying setting of newly placed concrete mixture to depth of reveal specified.

2.04 REINFORCING MATERIALS

- A. Reinforcing Bars: ASTM A 615/A 615M, Grade 60, deformed.
- B. Low-Alloy-Steel Reinforcing Bars: ASTM A 706/A 706M, deformed.
- C. Galvanized Reinforcing Bars: ASTM A 615/A 615M, Grade 60, deformed bars, with ASTM A 767/A 767M, Class II zinc coating and chromate treatment. Galvanize after fabrication and bending.
- D. Epoxy-Coated Reinforcing Bars: ASTM A 615/A 615M, Grade 60, deformed bars, epoxy coated, with less than 2 percent damaged coating in each 12-inch bar length.
- E. Steel Bar Mats: ASTM A 184/A 184M, fabricated from ASTM A 615/A 615M, Grade 60, deformed bars, assembled with clips.
- F. Plain-Steel Welded Wire Reinforcement: ASTM A 185/A 185M, fabricated from as-drawn steel wire into flat sheets.
- G. Deformed-Steel Welded Wire Reinforcement: ASTM A 497/A 497M or ASTM A 1064/A 1064M, flat sheet.
- H. Epoxy-Coated-Steel Wire: ASTM A 884/A 884M, Class A coated, plain, flat sheet, Type 1 bendable coating.
- I. Supports: Suspend reinforcement from back of mold or use bolsters, chairs, spacers, and other devices for spacing, supporting, and fastening reinforcing bars and welded wire reinforcement in place according to PCI MNL 116.

2.05 PRESTRESSING TENDONS

- A. Pretensioning Strand: ASTM A 416/A 416M, Grade 250 or Grade 270, uncoated, seven-wire or ASTM A 886/A 886M, Grade 270, indented, seven-wire, low-relaxation strand.
- B. Unbonded Post-Tensioning Strand: ASTM A 416/A 416M, Grade 270, uncoated, seven-wire, low-relaxation strand.
1. Coat unbonded post-tensioning strand with post-tensioning coating complying with ACI 423.7 and sheath with polypropylene tendon sheathing complying with ACI 423.7. Include anchorage devices and coupler assemblies.
- C. Post-Tensioning Bars: ASTM A 722/A 722M, uncoated high-strength steel bar.

2.06 CONCRETE MATERIALS

- A. Portland Cement: ASTM C 150/C 150M, Type I or Type III, gray, unless otherwise indicated.
1. For surfaces exposed to view in finished structure, use gray or white cement, of same type, brand, and mill source.
- B. Supplementary Cementitious Materials:
1. Fly Ash: ASTM C 618, Class C or F, with maximum loss on ignition of 3 percent.
 2. Metakaolin: ASTM C 618, Class N.
 3. Silica Fume: ASTM C 1240, with optional chemical and physical requirement.
 4. Ground Granulated Blast-Furnace Slag: ASTM C 989, Grade 100 or 120.
 5. Blended Hydraulic Cement: ASTM C 595/C 595M, Type IS, portland blast-furnace slag Type IP, portland-pozzolan Type I (PM), pozzolan-modified portland Type I (SM), slag-modified Portland cement.
- C. Normal-Weight Aggregates: Except as modified by PCI MNL 116, ASTM C 33/C 33M. Stockpile fine and coarse aggregates for each type of exposed finish from a single source (pit or quarry) for Project.
- D. Lightweight Aggregates: Except as modified by PCI MNL 116, ASTM C 330/C 330M, with absorption less than 11 percent.
- E. Coloring Admixture: ASTM C 979/C 979M, synthetic or natural mineral-oxide pigments or colored water-reducing admixtures, temperature stable, and nonfading.
- F. Water: Potable; free from deleterious material that may affect color stability, setting, or strength of concrete and complying with chemical limits of PCI MNL 116.
- G. Air-Entraining Admixture: ASTM C 260, certified by manufacturer to be compatible with other required admixtures.

034100 - PRECAST STRUCTURAL CONCRETE

H. Chemical Admixtures: Certified by manufacturer to be compatible with other admixtures and to not contain calcium chloride, or more than 0.15 percent chloride ions or other salts by weight of admixture.

1. Water-Reducing Admixtures: ASTM C 494/C 494M, Type A.
2. Retarding Admixture: ASTM C 494/C 494M, Type B.
3. Water-Reducing and Retarding Admixture: ASTM C 494/C 494M, Type D.
4. Water-Reducing and Accelerating Admixture: ASTM C 494/C 494M, Type E.
5. High-Range, Water-Reducing Admixture: ASTM C 494/C 494M, Type F.
6. High-Range, Water-Reducing and Retarding Admixture: ASTM C 494/C 494M, Type G.
7. Plasticizing Admixture: ASTM C 1017/C 1017M, Type I.
8. Plasticizing and Retarding Admixture: ASTM C 1017/C 1017M, Type II.
9. Corrosion-Inhibiting Admixture: ASTM C 1582/C 1582M.

2.07 STEEL CONNECTION MATERIALS

- A. Carbon-Steel Shapes and Plates: ASTM A 36/A 36M.
- B. Carbon-Steel-Headed Studs: ASTM A 108, Grade 1010 through 1020, cold finished, AWS D1.1/D1.1M, Type A or B, with arc shields and with minimum mechanical properties of PCI MNL 116.
- C. Carbon-Steel Plate: ASTM A 283/A 283M, Grade C.
- D. Malleable-Iron Castings: ASTM A 47/A 47M, Grade 32510 or Grade 35028.
- E. Carbon-Steel Castings: ASTM A 27/A 27M, Grade 60-30.
- F. High-Strength, Low-Alloy Structural Steel: ASTM A 572/A 572M.
- G. Carbon-Steel Structural Tubing: ASTM A 500/A 500M, Grade B or Grade C.
- H. Wrought Carbon-Steel Bars: ASTM A 675/A 675M, Grade 65.
- I. Deformed-Steel Wire or Bar Anchors: ASTM A 496/A 496M or ASTM A 706/A 706M.
- J. Carbon-Steel Bolts and Studs: ASTM A 307, Grade A; carbon-steel, hex-head bolts and studs; carbon-steel nuts, ASTM A 563; and flat, unhardened steel washers, ASTM F 844.
- K. High-Strength Bolts and Nuts: ASTM A 325 or ASTM A 490, Type 1, heavy hex steel structural bolts; heavy hex carbon-steel nuts, ASTM A 563; and hardened carbon-steel washers, ASTM F 436.
 1. Do not zinc coat ASTM A 490 bolts.
- L. Welding Electrodes: Comply with AWS standards.
- M. Precast Accessories: Provide clips, hangers, plastic or steel shims, and other accessories required to install precast structural concrete units.

2.08 STAINLESS STEEL CONNECTION MATERIALS

- A. Stainless Steel Plate: ASTM A 666, Type 304, Type 316, or Type 201.
- B. Stainless Steel Bolts and Studs: ASTM F 593, Alloy Group 1 or 2, hex-head bolts and studs; ASTM F 594, Alloy Group 1 or 2 stainless steel nuts; and flat, stainless steel washers.
 1. Lubricate threaded parts of stainless steel bolts with an anti-seize thread lubricant during assembly.
- C. Stainless Steel-Headed Studs: ASTM A 276, Alloy 304 or 316, with minimum mechanical properties of PCI MNL 116.

2.09 BEARING PADS

- A. Provide one of the following bearing pads for precast structural concrete units as recommended by precast fabricator for application:
 1. Elastomeric Pads: AASHTO M 251, plain, vulcanized, 100 percent polychloroprene (neoprene) elastomer, molded to size or cut from a molded sheet, 50 to 70 Shore, Type A durometer hardness, ASTM D 2240; minimum tensile strength 2250 psi, ASTM D 412.
 2. Random-Oriented-Fiber-Reinforced Elastomeric Pads: Preformed, randomly oriented synthetic fibers set in elastomer. 70 to 90 Shore, Type A durometer hardness, ASTM D 2240; capable of supporting a compressive stress of 3000 psi with no cracking, splitting, or delaminating in the internal portions of pad. Test one specimen for every 200 pads used in Project.
 3. Cotton-Duck-Fabric-Reinforced Elastomeric Pads: Preformed, horizontally layered cotton-duck fabric bonded to an elastomer; 80 to 100 Shore, Type A durometer hardness, ASTM D 2240; complying with AASHTO's "AASHTO LRFD Bridge Design Specifications," Division II, Section 18 .10.2; or with MIL-C-882E.
 4. Frictionless Pads: PTFE, glass-fiber reinforced, bonded to stainless or mild-steel plate, or random-oriented-fiber-reinforced elastomeric pads; of type required for in-service stress.
 5. High-Density Plastic: Multimonomer, non-leaching, plastic strip.

2.10 ACCESSORIES

- A. Precast Accessories: Provide clips, hangers, high-density plastic or steel shims, and other accessories required to install structural precast concrete units.

2.11 GROUT MATERIALS

A. Sand-Cement Grout: Portland cement, ASTM C 150/C 150M, Type I, and clean, natural sand, ASTM C144 or ASTM C 404.

Mix at ratio of 1 part cement to 2-1/2 to 3 parts sand, by volume, with minimum water required for placement and hydration.

Water-soluble chloride ion content less than 0.06 percent by weight of cement when tested according to ASTM C 1218/C 1218M.

B. Nonmetallic, Nonshrink Grout: Packaged, nonmetallic, noncorrosive, nonstaining grout containing selected silica sands, portland cement, shrinkage-compensating agents, plasticizing and water-reducing agents, complying with ASTM C 1107/C 1107M, Grade A for drypack and Grades B and C for flowable grout and of consistency suitable for application within a 30-minute working time. Water-soluble chloride ion content less than 0.06 percent by weight of cement when tested according to ASTM C1218/C 1218M.

2.12 CONCRETE MIXTURES

A. Prepare design mixtures for each type of precast concrete required.

1. Use fly ash, pozzolan, ground granulated blast-furnace slag, and silica fume as needed to reduce the total amount of portland cement, which would otherwise be used, by not less than 40 percent.

2. Limit use of fly ash to 20 percent replacement of portland cement by weight and ground granulated blast-furnace slag to 20 percent of portland cement by weight; metakaolin and silica fume to 10 percent of portland cement by weight.

B. Design mixtures may be prepared by a qualified independent testing agency or by qualified precast plant personnel at precast structural concrete fabricator's option.

C. Limit water-soluble chloride ions to maximum percentage by weight of cement permitted by ACI 318 or PCI MNL 116 when tested according to ASTM C 1218/C 1218M.

D. Normal-Weight Concrete Mixtures: Proportion full-depth mixture by either laboratory trial batch or field test data methods according to ACI 211.1, with materials to be used on Project, to provide normal-weight concrete with the following properties:

1. Compressive Strength (28 Days): As required by Precast Designer.

2. Maximum Water-Cementitious Materials Ratio: 0.45.

E. Water Absorption: For structural precast concrete with an architectural finish, limit water absorption to 6 percent by weight or 14 percent by volume, tested according to ASTM C 642, except for boiling requirement.

1. Unit Weight: Calculated equilibrium unit weight of 115 lb/cu. ft., plus or minus 3 lb/cu. ft., according to ASTM C 567.

F. Add air-entraining admixture at manufacturer's prescribed rate to result in concrete at point of placement having an air content complying with PCI MNL 116.

G. When included in design mixtures, add other admixtures to concrete mixtures according to manufacturer's written instructions.

H. Concrete Mix Adjustments: Concrete mix design adjustments may be proposed if characteristics of materials, Project conditions, weather, test results, or other circumstances warrant.

2.13 MOLD FABRICATION

A. Molds: Accurately construct molds, mortar tight, of sufficient strength to withstand pressures due to concrete-placement operations and temperature changes and for prestressing and de-tensioning operations. Coat contact surfaces of molds with release agent before reinforcement is placed. Avoid contamination of reinforcement and prestressing tendons by release agent.

1. Place form liners accurately to provide finished surface texture indicated. Provide solid backing and supports to maintain stability of liners during concrete placement. Coat form liner with form-release agent.

B. Maintain molds to provide completed precast structural concrete units of shapes, lines, and dimensions indicated, within fabrication tolerances specified.

1. Form joints are not permitted on faces of structural precast concrete with an architectural finish that is exposed to view in the finished work.

2.14 FABRICATION

A. Cast-in Anchors, Inserts, Plates, Angles, and Other Anchorage Hardware: Fabricate anchorage hardware with sufficient anchorage and embedment to comply with design requirements. Accurately position for attachment of loose hardware, and secure in place during precasting operations. Locate anchorage hardware where it does not affect position of main reinforcement or concrete placement.

1. Weld-headed studs and deformed bar anchors used for anchorage according to AWS D1.1/D1.1M and AWS C5.4, "Recommended Practices for Stud Welding."

B. Furnish loose hardware items including steel plates, clip angles, seat angles, anchors, dowels, cramps, hangers, and other hardware shapes for securing precast structural concrete units to supporting and adjacent construction.

C. Cast-in reglets, slots, holes, and other accessories in precast structural concrete units as indicated on the Contract Drawings.

D. Cast-in openings larger than 10 inches in any dimension. Do not drill or cut openings or prestressing strand without Architect's approval.

034100 - PRECAST STRUCTURAL CONCRETE

- E. Reinforcement: Comply with recommendations in PCI MNL 116 for fabricating, placing, and supporting reinforcement.
1. Clean reinforcement of loose rust and mill scale, earth, and other materials that reduce or destroy the bond with concrete. When damage to epoxy-coated reinforcement exceeds limits specified in ASTM A 775/A 775M, repair with patching material compatible with coating material and epoxy coat bar ends after cutting.
 2. Accurately position, support, and secure reinforcement against displacement during concrete-placement and consolidation operations. Completely conceal support devices to prevent exposure on finished surfaces.
 3. Place reinforcing steel and prestressing strand to maintain at least 3/4-inch minimum concrete cover. Increase cover requirements for reinforcing steel to 1-1/2 inches when units are exposed to corrosive environment or severe exposure conditions. Arrange, space, and securely tie bars and bar supports to hold reinforcement in position while placing concrete. Direct wire tie ends away from finished, exposed concrete surfaces.
 4. Install welded wire fabric in lengths as long as practicable. Lap adjoining pieces at least one full mesh spacing and wire tie laps, where required by design. Offset laps of adjoining widths to prevent continuous laps in either direction.
- F. Reinforce precast structural concrete units to resist handling, transportation, and erection stresses and specified in-place loads.
- G. Prestress tendons for precast structural concrete units by either pretensioning or post-tensioning methods.
- Comply with PCI MNL 116.
1. Delay detensioning or post-tensioning of precast, prestressed structural concrete units until concrete has reached its indicated minimum design release compressive strength as established by test cylinders cured under same conditions as concrete unit.
 2. Detension pretensioned tendons either by gradually releasing tensioning jacks or by heat cutting tendons, using a sequence and pattern to prevent shock or unbalanced loading.
 3. If concrete has been heat cured, detension while concrete is still warm and moist to avoid dimensional changes that may cause cracking or undesirable stresses.
 4. Protect strand ends and anchorages with bituminous, zinc-rich, or epoxy paint to avoid corrosion and possible rust spots.
 5. Protect strand ends and anchorages with a minimum of 1-inch-thick, nonmetallic, nonshrink, grout mortar and sack rub surface. Coat or spray the inside surfaces of pocket with bonding agent before installing grout.
- H. Comply with requirements in PCI MNL 116 and in this Section for measuring, mixing, transporting, and placing concrete. After concrete batching, no additional water may be added.
- I. Place face mixture to a minimum thickness after consolidation of the greater of 1 inch or 1.5 times the maximum aggregate size, but not less than the minimum reinforcing cover specified.
- J. Place concrete in a continuous operation to prevent cold joints or planes of weakness from forming in precast concrete units.
- K. Thoroughly consolidate placed concrete by vibration without dislocating or damaging reinforcement and built-in items, and minimize pour lines, honeycombing, or entrapped air voids on surfaces. Use equipment and procedures complying with PCI MNL 116.
1. Place self-consolidating concrete without vibration according to PCI TR-6, "Interim Guidelines for the Use of Self-Consolidating Concrete in Precast/Prestressed Concrete Institute Member Plants." Ensure adequate bond between face and backup concrete, if used.
- L. Comply with PCI MNL 116 procedures for hot- and cold-weather concrete placement.
- M. Identify pickup points of precast structural concrete units and orientation in structure with permanent markings, complying with markings indicated on Shop Drawings. Imprint or permanently mark casting date on each precast structural concrete unit on a surface that does not show in finished structure.
- N. Cure concrete, according to requirements in PCI MNL 116, by moisture retention without heat or by accelerated heat curing using live steam or radiant heat and moisture. Cure units until compressive strength is high enough to ensure that stripping does not have an effect on performance or appearance of final product.
- O. Discard and replace precast structural concrete units that do not comply with requirements, including structural, manufacturing tolerance, and appearance, unless repairs meet requirements in PCI MNL 116 and meet Architect's approval.

2.15 FABRICATION TOLERANCES

- A. Fabricate precast structural concrete units to shapes, lines, and dimensions indicated so each finished unit complies with PCI MNL 116 product dimension tolerances as well as position tolerances for cast-in items.

2.16 COMMERCIAL FINISHES

- A. Standard Grade: Normal plant-run finish produced in molds that impart a smooth finish to concrete. Surface holes smaller than 1/2 inch caused by air bubbles, normal color variations, form joint marks, and minor chips and spalls are permitted. Fill air holes greater than 1/4 inch in width that occur more than once per 2 sq. in.. Major or unsightly imperfections, honeycombs, or structural defects are not permitted. Limit joint offsets to 1/8 inch.
- B. Screed or float finish unformed surfaces. Strike off and consolidate concrete with vibrating screeds to a uniform finish. Hand screed at projections. Normal color variations, minor indentations, minor chips, and spalls are permitted. Major imperfections, honeycombing, or defects are not permitted.

PART 3 - EXECUTION

3.01 EXAMINATION

- A. Examine supporting structural frame or foundation and conditions for compliance with requirements for installation tolerances, bearing surface tolerances, and other conditions affecting performance of the Work.
- B. Proceed with installation only after unsatisfactory conditions have been corrected.
- C. Do not install precast concrete units until supporting, cast-in-place concrete has attained minimum allowable design compressive strength and until supporting steel or other structure is structurally ready to receive loads from precast concrete units.

3.02 INSTALLATION

- A. Install clips, hangers, bearing pads, and other accessories required for connecting precast structural concrete units to supporting members and backup materials.
- B. Erect precast structural concrete level, plumb, and square within specified allowable tolerances. Provide temporary structural framing, shoring, and bracing as required to maintain position, stability, and alignment of units until permanent connections are complete.
 - 1. Install temporary steel or plastic spacing shims or bearing pads as precast structural concrete units are being erected. Tack weld steel shims to each other to prevent shims from separating.
 - 2. Maintain horizontal and vertical joint alignment and uniform joint width as erection progresses.
 - 3. Remove projecting lifting devices and use plastic patch caps or sand-cement grout to fill voids within recessed lifting devices flush with surface of adjacent precast surfaces when recess is exposed.
- C. Connect precast structural concrete units in position by bolting, welding, grouting, or as otherwise indicated on Shop Drawings. Remove temporary shims, wedges, and spacers as soon as practical after connecting and grouting are completed.
 - 1. Do not permit connections to disrupt continuity of roof flashing.
- D. Field cutting of precast units is not permitted without approval of Architect.
- E. Fasteners: Do not use drilled or powder-actuated fasteners for attaching accessory items to precast, prestressed concrete units.
- F. Welding: Comply with applicable requirements in AWS D1.1/D1.1M and AWS D1.4/D1.4M for welding, welding electrodes, appearance, quality of welds, and methods used in correcting welding work.
 - 1. Protect precast structural concrete units and bearing pads from damage by field welding or cutting operations, and provide noncombustible shields as required.
 - 2. Clean weld-affected steel surfaces with chipping hammer followed by brushing, and apply a minimum 4.0-mil-thick coat of galvanized repair paint to galvanized surfaces according to ASTM A780/A 780M.
 - 3. Clean weld-affected steel surfaces with chipping hammer followed by brushing, and reprime damaged painted surfaces.
 - 4. Visually inspect welds and remove, reweld, or repair incomplete and defective welds.
- G. At bolted connections, use lock washers, tack welding, or other approved means to prevent loosening of nuts after final adjustment.
 - 1. Where slotted connections are used, verify bolt position and tightness. For sliding connections, properly secure bolt but allow bolt to move within connection slot.
 - 2. For slip-critical connections, use one of the following methods to assure proper bolt pretension:
 - a. Turn-of-Nut: According to RCSC's "Specification for Structural Joints Using ASTM A 325 or A490 Bolts."
 - b. Calibrated Wrench: According to RCSC's "Specification for Structural Joints Using ASTM A 325 or A 490 Bolts."
 - c. Twist-off Tension Control Bolt: ASTM F 1852.
 - d. Direct-Tension Control Bolt: ASTM F 1852.
 - 3. For slip-critical connections, use method and inspection procedure approved by Architect and coordinated with inspection agency.
- H. Grouting or Dry-Packing Connections and Joints: Grout connections and joints and open spaces at keyways, connections, and joints where required or indicated on Shop Drawings. Retain flowable grout in place until hard enough to support itself. Alternatively, pack spaces with stiff dry-pack grout material, tamping until voids are completely filled.
 - 1. Place grout and finish smooth, level, and plumb with adjacent concrete surfaces.
 - 2. Fill joints completely without seepage to other surfaces.
 - 3. Trowel top of grout joints on roofs smooth and uniform. Finish transitions between different surface levels not steeper than 1 to 12.
 - 4. Place grout end cap or dam in voids at ends of hollow-core slabs.
 - 5. Promptly remove grout material from exposed surfaces before it affects finishes or hardens.
 - 6. Keep grouted joints damp for not less than 24 hours after initial set.

034100 - PRECAST STRUCTURAL CONCRETE

3.03 ERECTION TOLERANCES

- A. Erect precast structural concrete units level, plumb, square, and in alignment without exceeding the noncumulative erection tolerances of PCI MNL 135.
- B. Minimize variations between adjacent slab members by jacking, loading, or other method recommended by fabricator and approved by Architect.

3.04 FIELD QUALITY CONTROL

- A. Special Inspections: Owner will engage a qualified special inspector to perform the following special inspections:
 - 1. Erection of precast structural concrete members.
- B. Testing Agency: Owner will engage a qualified testing agency to perform tests and inspections.
- C. Visually inspect field welds and test according to ASTM E 165 or to ASTM E 709 and ASTM E 1444. High-strength bolted connections are subject to inspections.
- D. Testing agency will report test results promptly and in writing to Contractor and Architect.
- E. Repair or remove and replace work where tests and inspections indicate that it does not comply with specified requirements.
- F. Additional testing and inspecting, at Contractor's expense, shall be performed to determine compliance of replaced or additional work with specified requirements.
- G. Prepare test and inspection reports.

3.05 REPAIRS

- A. Repair precast structural concrete units if permitted by Architect.
 - 1. Repairs may be permitted if structural adequacy, serviceability, durability, and appearance of units have not been impaired.
- B. Mix patching materials and repair units so cured patches blend with color, texture, and uniformity of adjacent exposed surfaces and show no apparent line of demarcation between original and repaired work, when viewed in typical daylight illumination from a distance of 20 feet.
- C. Prepare and repair damaged galvanized coatings with galvanizing repair paint according to ASTM A 780/A 780M.
- D. Wire brush, clean, and paint damaged prime-painted components with same type of shop primer.
- E. Remove and replace damaged precast structural concrete units that cannot be repaired or when repairs do not comply with requirements as determined by Architect.

3.06 CLEANING

- A. Clean mortar, plaster, fireproofing, weld slag, and other deleterious material from concrete surfaces and adjacent materials immediately.
- B. Clean exposed surfaces of precast concrete units after erection and completion of joint treatment to remove weld marks, other markings, dirt, and stains.
 - 1. Perform cleaning procedures, if necessary, according to precast concrete fabricator's written recommendations. Protect other work from staining or damage due to cleaning operations.
 - 2. Do not use cleaning materials or processes that could change the appearance of exposed concrete finishes or damage adjacent materials.

SECTION 03 5400 - CAST UNDERLAYMENT

PART 1 GENERAL

1.01 SECTION INCLUDES: Liquid-applied self-leveling floor underlayment.

1.02 REFERENCE STANDARDS

A. ASTM C472 - Standard Test Methods for Physical Testing of Gypsum, Gypsum Plasters and Gypsum Concrete; 1999 (Reapproved 2014).

B. ASTM E84 - Standard Test Method for Surface Burning Characteristics of Building Materials; 2015a.

1.03 SUBMITTALS

A. See Section 01 3000 - Administrative Requirements, for submittal procedures.

B. Product Data: Provide manufacturer's data sheets documenting physical characteristics and product limitations of underlayment materials. Include information on surface preparation, mixing instructions, environmental limitations, storage and handling requirements, and installation instructions.

1.04 QUALITY ASSURANCE

A. Applicator Qualifications: Company specializing in performing the work of this section, and approved by manufacturer.

1.05 DELIVERY, STORAGE, AND HANDLING

A. Store products in manufacturer's unopened packaging until ready for installation.

B. Keep dry and protect from direct sun exposure, freezing, and ambient temperature greater than 105 degrees F (41 degrees C).

1.06 FIELD CONDITIONS

A. Do not install underlayment until floor penetrations and peripheral work are complete.

B. Maintain minimum ambient temperatures of 50 degrees F (10 degrees C) 24 hours before, during and 72 hours after installation of underlayment.

C. During the curing process, ventilate spaces to remove excess moisture.

PART 2 PRODUCTS

2.01 MANUFACTURERS

A. Gypsum Underlayment:

1. ARDEX Engineered Cements: www.ardexamericas.com.

2. Dependable Chemical Co., Inc: www.floorprep.com.

3. Hacker Industries, Inc: www.hackerindustries.com.

4. Maxxon Corporation: www.maxxon.com.

5. Substitutions: See Section 01 6000 - Product Requirements.

2.02 MATERIALS

A. Gypsum-Based Underlayment <CAST UNDLMNT-1>: Gypsum based mix, that when mixed with water in accordance with manufacturer's directions will produce self-leveling underlayment with the following properties:

1. Basis of Design: Gyp-Crete by Maxxon Corporation.

2. Application: All areas indicated to receive carpet or other soft flooring materials.

3. Compressive Strength: Minimum 2200 psi (15 MPa), tested per ASTM C472.

4. Density: Maximum 115 lb/cu ft (1842 kg/cu m).

5. Final Set Time: 1 to 2 hours, maximum.

6. Thickness: 3/4 inch (19 mm) to maximum 3-1/2 inch (89 mm).

7. Surface Burning Characteristics: Flame spread/Smoke developed index of 0/0 in accordance with ASTM E84.

B. Gypsum-Based Underlayment <CAST UNDLMNT-1>: Gypsum based mix, that when mixed with water in accordance with manufacturer's directions will produce self-leveling underlayment with the following properties:

1. Basis of Design: Dura-Cap by Maxxon Corporation.

2. Application: All areas indicated to receive linoleum, tile, or other resilient flooring materials.

3. Compressive Strength: Minimum 3500 psi (24.13 MPa), tested per ASTM C472.

4. Density: Maximum 115 lb/cu ft (1842 kg/cu m).

5. Final Set Time: 1 to 2 hours, maximum.

6. Thickness: 1/2 inch (13 mm) to maximum 3-1/2 inch (89 mm).

7. Surface Burning Characteristics: Flame spread/Smoke developed index of 0/0 in accordance with ASTM E84.

C. Sound Deadening Mat <CAST UNDLMNT-12>: Gypsum based underlayment above with sound deadening mat.

1. Basis of Design: Acousti-Mat II by Maxxon Corporation.

2. Thickness: 1/4 inch.

D. Aggregate: Dry, well graded, washed silica aggregate, approximately 1/8 inch (3 mm) in size and acceptable to underlayment manufacturer.

E. Water: Potable and not detrimental to underlayment mix materials.

F. Primer: Manufacturer's recommended type.

G. Joint and Crack Filler: Latex based filler, as recommended by manufacturer.

SECTION 03 5400 - CAST UNDERLAYMENT

2.03 MIXING

- A. Site mix materials in accordance with manufacturer's instructions.
- B. Add aggregate for areas where thickness will exceed 1/2 inch (12.7 mm). Mix underlayment and water for at least two minutes before adding aggregate, and continue mixing to assure that aggregate has been thoroughly coated.
- C. Mix to self-leveling consistency without over-watering.

PART 3 EXECUTION

3.01 EXAMINATION

- A. Verify that substrate surfaces are clean, dry, unfrozen, do not contain petroleum byproducts, or other compounds detrimental to underlayment material bond to substrate.

3.02 PREPARATION

- A. Concrete: Mechanically prepare steel troweled concrete to create a textured surface necessary to achieve the best bond; acceptable methods include bead blasting and scarifying. Do not use acid etching.
- B. Remove substrate surface irregularities. Fill voids and deck joints with filler. Finish smooth.
- C. Vacuum clean surfaces.
- D. Prime substrate in accordance with manufacturer's instructions. Allow to dry.
- E. Close floor openings.

3.03 APPLICATION

- A. Install underlayment in accordance with manufacturer's instructions.
- B. Pump or pour material onto substrate. Do not retemper or add water.
 - 1. Pump, move, and screed while the material is still highly flowable.
 - 2. Be careful not to create cold joints.
 - 3. Wear spiked shoes while working in the wet material to avoid leaving marks.
- C. Place to indicated thickness, with top surface level to 1/8 inch in 10 ft (1:1000).

3.04 CURING

- A. Once underlayment starts to set, prohibit foot traffic until final set has been reached.
- B. Air cure in accordance with manufacturer's instructions.

3.05 PROTECTION

- A. Protect against direct sunlight, heat, and wind; prevent rapid drying to avoid shrinkage and cracking.
- B. Do not permit traffic over unprotected floor underlayment surfaces.

PART 1 GENERAL

- A. Provide all labor and materials, including equipment and supervision for the installation of Foundation Insulation as described in the contract documents.
- B. Installation shall be conducted in strict accordance to the manufacturer's recommendations.

PART 2 - PRODUCTS

2.1 MATERIALS

- A. Rigid closed-cell extruded polystyrene board insulation.
- B. Materials shall meet or exceed the R-value requirement and is suitable for the specified application.
- C. Procure or approved equal shall be used.
- D. Pourable foundation block insulation shall be manufactured for the specific purpose of insulating block cavities.

PART 3 - EXECUTION

- A. Rigid foam insulation is to be installed in strict accordance to manufacturer's guidelines.
- B. Protect board from physical damage. Handle boards carefully so corners are not broken and boards are damaged.
- C. Verify all masonry joints are struck flush and all projections that will interfere with proper installations are removed.
- D. Material is to be placed in all locations indicated in the contract documents.
- E. Material is to be secured in place using approved methods. (Caution: some glues will deteriorate foam; do not use.)
- F. Caution is to be taken when placement is located below grade to prevent backfill material from lodging between the insulating material and the foundation wall.

1. PART 1 GENERAL

1.1 RELATED DOCUMENTS

A. Drawings and general provisions of the Contract, including General and Supplementary Conditions and Division 1 Specification Sections, apply to this Section.

1.2 SUMMARY

A. This Section includes unit masonry assemblies consisting of the following:

1. Concrete masonry units (CMUs).
2. Mortar and grout.
3. Reinforcing steel.
4. Masonry joint reinforcement.
5. Ties and anchors.

B. Related Sections include the following:

1. Division 3 Section "Unit Masonry" for veneer, veneer anchorage, drainage, waterproofing, insulating, flashing, and wicking
2. Division 7 Section "Bituminous Dampproofing" for dampproofing applied to cavity face of backup wythes of cavity walls
3. Division 7 Section "Water Repellents" for water repellents applied to unit masonry assemblies.
4. Division 7 Section "Through-Penetration Firestop Systems" for firestopping at openings in masonry walls.
5. Division 7 Section "Fire-Resistive Joint Systems" for fire-resistive joint systems at heads of masonry walls.
6. Division 7 Section "Joint Sealants" for sealing control and expansion joints in unit masonry.

C. Products furnished, but not installed, under this Section include the following:

1. Anchor sections of adjustable masonry anchors for connecting to structural frame, installed under Division 5 Section "Structural Steel."
2. Dovetail slots for masonry anchors, installed under Division 3 Section "Cast-in-Place Concrete."

D. Products installed, but not furnished, under this Section include the following:

1. Steel lintels and shelf angles for unit masonry, furnished under Division 5 Section "Metal Fabrications."
2. Manufactured reglets in masonry joints for metal flashing, furnished under Division 7 Section "Sheet Metal Flashing and Trim."

1.3 DEFINITIONS

A. Reinforced Masonry: Masonry containing reinforcing steel in grouted cells.

1.4 PERFORMANCE REQUIREMENTS

A. Provide structural unit masonry that develops indicated net-area compressive strengths (f'm) at 28 days.

B. Determine net-area compressive strength (f'm) of masonry from average net-area compressive strengths of masonry units and mortar types (unit-strength method) according to Tables 1 and 2 in ACI 530.1/ASCE 6/TMS 602.

1.5 SUBMITTALS

A. Product Data: For each type of product indicated.

B. Shop Drawings: For the following:

1. Masonry Units: Show sizes, profiles, coursing, and locations of special shapes.
2. Reinforcing Steel: Detail bending and placement of unit masonry reinforcing bars. Comply with ACI 315, "Details and Detailing of Concrete Reinforcement." Show elevations of reinforced walls.

C. Qualification Data: For testing agency.

D. Material Certificates: Include statements of material properties indicating compliance with requirements including compliance with standards and type designations within standards. Provide for each type and size of the following:

1. Masonry units.
 - a. Include material test reports substantiating compliance with requirements.
 - b. For masonry units used in structural masonry, include data and calculations establishing average net-area compressive strength of units.
2. Cementitious materials. Include brand, type, and name of manufacturer.
3. Grout mixes. Include description of type and proportions of ingredients.
4. Reinforcing bars.
5. Joint reinforcement.
6. Anchors, ties, and metal accessories.

1.5 SUBMITTALS

E. Mix Designs: For each type of mortar and grout. Include description of type and proportions of ingredients.

1. Include test reports, per ASTM C 780, for mortar mixes required to comply with property specification.

2. Include test reports, per ASTM C 1019, for grout mixes required to comply with compressive strength requirement.

F. Statement of Compressive Strength of Masonry: For each combination of masonry unit type and mortar type, provide statement of average net-area compressive strength of masonry units, mortar type, and resulting net-area compressive strength of masonry determined according to Tables 1 and 2 in ACI 530.1/ASCE 6/TMS 602.

G. Cold-Weather Procedures: Detailed description of methods, materials, and equipment to be used to comply with cold-weather requirements.

1.6 QUALITY ASSURANCE

A. Source Limitations for Masonry Units: Obtain exposed masonry units of a uniform texture and color, or a uniform blend within the ranges accepted for these characteristics, through one source from a single manufacturer for each product required.

B. Source Limitations for Mortar Materials: Obtain mortar ingredients of a uniform quality, including color for exposed masonry, from a single manufacturer for each cementitious component and from one source or producer for each aggregate.

1.7 DELIVERY, STORAGE, AND HANDLING

A. Store masonry units on elevated platforms in a dry location. If units are not stored in an enclosed location, cover tops and sides of stacks with waterproof sheeting, securely tied. If units become wet, do not install until they are dry.

B. Store cementitious materials on elevated platforms, under cover, and in a dry location. Do not use cementitious materials that have become damp.

C. Store aggregates where grading and other required characteristics can be maintained and contamination avoided.

D. Store masonry accessories, including metal items, to prevent corrosion and accumulation of dirt and oil.

1.8 PROJECT CONDITIONS

A. Protection of Masonry: During construction, cover tops of walls, projections, and sills with waterproof sheeting at end of each day's work. Cover partially completed masonry when construction is not in progress.

1. Extend cover a minimum of 24 inches down both sides and hold cover securely in place.

B. Do not apply uniform floor or roof loads for at least 12 hours and concentrated loads for at least 3 days after building masonry walls or columns.

C. Stain Prevention: Prevent grout, mortar, and soil from staining the face of masonry to be left exposed or painted. Immediately remove grout, mortar, and soil that come in contact with such masonry.

1. Protect sills, ledges, and projections from mortar droppings.

2. Protect surfaces of window and door frames, as well as similar products with painted and integral finishes, from mortar droppings.

D. Cold-Weather Requirements: Do not use frozen materials or materials mixed or coated with ice or frost.

Do not build on frozen substrates. Remove and replace unit masonry damaged by frost or by freezing conditions. Comply with cold-weather construction requirements contained in ACI 530.1/ASCE 6/TMS 602.

1. Cold-Weather Cleaning: Use liquid cleaning methods only when air temperature is 40 deg F (4 deg C) and above and will remain so until masonry has dried, but not less than 7 days after completing cleaning.

E. Hot-Weather Requirements: Comply with hot-weather construction requirements contained in ACI 530.1/ASCE 6/TMS 602.

PART 2 - PRODUCTS

2.1 MANUFACTURERS

A. In other Part 2 articles where titles below introduce lists, the following requirements apply to product selection:

1. Available Products: Subject to compliance with requirements, products that may be incorporated into the Work include, but are not limited to, products specified.

2. Products: Subject to compliance with requirements, provide one of the products specified.

3. Available Manufacturers: Subject to compliance with requirements, manufacturers offering products that may be incorporated into the Work include, but are not limited to, manufacturers specified.

4. Manufacturers: Subject to compliance with requirements, provide products by one of the manufacturers specified.

2.2 MASONRY UNITS, GENERAL

A. Defective Units: Referenced masonry unit standards may allow a certain percentage of units to exceed tolerances and to contain chips, cracks, or other defects exceeding limits stated in the standard. Do not use units where such defects, including dimensions that vary from specified dimensions by more than stated tolerances, will be exposed in the completed Work or will impair the quality of completed masonry.

2.3 CONCRETE MASONRY UNITS (CMUs)

A. Shapes: Provide shapes indicated and as follows:

1. Provide special shapes for lintels, corners, jambs, sashes, movement joints, headers, bonding, and other special conditions.
2. Provide square edge units for outside corners, unless otherwise indicated.

B. Integral Water Repellent: Provide units made with integral water repellent for exposed units and where indicated.

1. Integral Water Repellent: Liquid polymeric, integral water-repellent admixture that does not reduce flexural bond strength. Units made with integral water repellent, when tested as a wall assembly made with mortar containing integral water-repellent manufacturer's mortar additive according to ASTM E 514, with test period extended to 24 hours, show no visible water or leaks on the back of test specimen.

1. Available Products:

- a. Addiment Incorporated; Block Plus W-10.
- b. Grace Construction Products, a unit of W. R. Grace & Co. - Conn.; Dry-Block.
- c. Master Builders, Inc.; Rheopel.

C. Concrete Masonry Units: ASTM C 90.

1. Unit Compressive Strength: Provide units with minimum average net-area compressive strength of 1900 psi.
2. Weight Classification: Lightweight or normal weight (must comply with structural requirements indicated in plans and spec.)
3. Size (Width): Manufactured to dimensions 3/8 inch less than nominal dimensions.
4. Size (Width): Manufactured to dimensions indicated on drawings:
5. Exposed Faces: Provide color and texture matching the range represented by Owner's selected sample.

2.4 MASONRY LINTELS

A. General: Provide masonry lintels complying with requirements below.

B. Masonry Lintels: Prefabricated or built-in-place masonry lintels made from bond beam concrete masonry units with reinforcing bars placed as indicated and filled with coarse grout. Cure precast lintels before handling and installing. Temporarily support built-in-place lintels until cured.

2.5 MORTAR AND GROUT MATERIALS

A. Portland Cement: ASTM C 150, Type I or II, except Type III may be used for cold-weather construction. Provide natural color or white cement as required to produce mortar color indicated.

B. Hydrated Lime: ASTM C 207, Type S.

C. Aggregate for Mortar: ASTM C 144.

1. For mortar that is exposed to view, use washed aggregate consisting of natural sand or crushed stone.

D. Aggregate for Grout: ASTM C 404.

E. Cold-Weather Admixture: Nonchloride, noncorrosive, accelerating admixture complying with ASTM C 494/C 494M, Type C, and recommended by manufacturer for use in masonry mortar of composition indicated.

1. Available Products:

- a. Addiment Incorporated; Mortar Kick.
- b. Euclid Chemical Company (The); Accelguard 80.
- c. Grace Construction Products, a unit of W. R. Grace & Co. - Conn.; Morset.
- d. Sonneborn, Div. of ChemRex; Trimix-NCA.

F. Water: Potable.

2.6 REINFORCEMENT

A. Uncoated Steel Reinforcing Bars: ASTM A 615/A 615M or ASTM A 996/A 996M,

B. Masonry Joint Reinforcement, General: ASTM A 95.

1. Interior Walls: mill
2. Exterior Walls: hot-dip galvanized
3. Wire Size for Side Rods: W1.7
4. Wire Size for Cross Rods: W1.7
5. Wire Size for Veneer Ties: W1.7
6. Spacing of Cross Rods, Tabs, and Cross Ties: Not more than 16 inches.
7. Provide in lengths of not less than 10 feet (3 m), with prefabricated corner and tee units.

C. Masonry Joint Reinforcement for Single-Wythe Masonry: Either ladder or truss type with single pair of side rods.

D. Masonry Joint Reinforcement for Multi-wythe Masonry:

1. Tab type, either ladder or truss design, with 1 side rod at each face shell of backing wythe and with rectangular tabs sized to extend at least halfway through facing wythe but with at least 5/8-inch (16-mm) cover on outside face.

2.7 TIES AND ANCHORS

A. Materials: Provide ties and anchors specified in subsequent paragraphs that are made from materials that comply with eight subparagraphs below, unless otherwise indicated.

1. Mill-Galvanized, Carbon-Steel Wire: ASTM A 82; with ASTM A 641/A 641M, Class 1 coating.
2. Stainless-Steel Wire in pool: ASTM A 580/A 580M, Type 304.
3. Steel Sheet, Galvanized after Fabrication: ASTM A 1008/A 1008M, Commercial Steel, hot-dip galvanized after fabrication to comply with ASTM A 153/A 153M.
4. Stainless-Steel Sheet in pool: ASTM A 666, Type 304.

B. Adjustable Anchors for Connecting to Structure: Provide anchors that allow vertical or horizontal adjustment but resist tension and compression forces perpendicular to plane of wall.

1. Tie Section for Steel Frame: Triangular-shaped wire tie, sized to extend within 1 inch of masonry face, made from 0.188-inch diameter, hot-dip galvanized steel.
2. Connector Section for Concrete: Dovetail tabs for inserting into dovetail slots in concrete and attached to tie section; formed from .053 inch thick steel sheet galvanized after fabrication.

2.8 MISCELLANEOUS ANCHORS

A. Dovetail Slots in Concrete: Furnish dovetail slots with filler strips, of slot size indicated, fabricated from .034 inch galvanized steel sheet.

2.9 MISCELLANEOUS MASONRY ACCESSORIES

A. Preformed Control-Joint Gaskets: Made from styrene-butadiene-rubber compound, complying with ASTM D 2000, Designation M2AA-805 or PVC, complying with ASTM D 2287, Type PVC-6540J and designed to fit standard sash block and to maintain lateral stability in masonry wall; size and configuration as indicated.

B. Bond-Breaker Strips: Asphalt-saturated, organic roofing felt complying with ASTM D 226, Type I (No. 15 asphalt felt).

C. Reinforcing Bar Positioners: Wire units designed to fit into mortar bed joints spanning masonry unit cells with loops for holding reinforcing bars in center of cells. Units are formed from .142 inch steel wire, hotdip galvanized after fabrication. Provide units with either two loops or four loops as needed for number of bars indicated.

1. Available Products:
 - a. Dayton Superior Corporation, Dur-O-Wal Division; D/A 810, D/A 812 or D/A 817.
 - b. Heckmann Building Products Inc.; No. 376 Rebar Positioner.
 - c. Hohmann & Barnard, Inc.; #RB or #RB-Twin Rebar Positioner.
 - d. Wire-Bond; O-Ring or Double O-Ring Rebar Positioner.

2.10 MASONRY CLEANERS

A. Proprietary Acidic Cleaner: Manufacturer's standard-strength cleaner designed for removing mortar/grout stains, efflorescence, and other new construction stains from new masonry without discoloring or damaging masonry surfaces. Use product expressly approved for intended use by cleaner manufacturer and manufacturer of masonry units being cleaned.

1. Available Manufacturers:
 - a. Diedrich Technologies, Inc.
 - b. EaCo Chem, Inc.
 - c. ProSoCo, Inc.

2.11 MORTAR AND GROUT MIXES

A. General: Do not use admixtures, including pigments, air-entraining agents, accelerators, retarders, water repellent agents, antifreeze compounds, or other admixtures, unless otherwise indicated.

1. Do not use calcium chloride in mortar or grout.
2. Limit cementitious materials in mortar for and reinforced masonry to portland cement and lime.
3. Add cold-weather admixture (if used) at same rate for all mortar that will be exposed to view, regardless of weather conditions, to ensure that mortar color is consistent.

B. Mortar for Unit Masonry: Comply with ASTM C 270, Proportion Specification. Provide the following types of mortar for applications stated unless another type is indicated

1. For masonry below grade or in contact with earth, use Type M or S.
2. For reinforced masonry, use Type S.

C. Grout for Unit Masonry: Comply with ASTM C 476.

1. Use grout of type indicated or, if not otherwise indicated, of type (fine or coarse) that will comply with Table 1.15.1 in ACI 530.1/ASCE 6/TMS 602 for dimensions of grout spaces and pour height.
2. Provide grout with a slump of 8 to 11 inches as measured according to ASTM C 143/C 143M.

PART 3 - EXECUTION**3.1 EXAMINATION**

- A. Examine conditions, with Installer present, for compliance with requirements for installation tolerances and other conditions affecting performance of work.
1. For the record, prepare written report, endorsed by Installer, listing conditions detrimental to performance of work.
 2. Verify that foundations are within tolerances specified.
 3. Verify that reinforcing dowels are properly placed.
- B. Before installation, examine rough-in and built-in construction for piping systems to verify actual locations of piping connections.
- C. Proceed with installation only after unsatisfactory conditions have been corrected.

3.2 INSTALLATION, GENERAL

- A. Thickness: Build cavity and composite walls and other masonry construction to full thickness shown. Build single-wythe walls to actual widths of masonry units, using units of widths indicated.
- B. Build chases and recesses to accommodate items specified in this and other Sections.
- C. Leave openings for equipment to be installed before completing masonry. After installing equipment, complete masonry to match the construction immediately adjacent to opening.
- D. Use full-size units without cutting if possible. If cutting is required to provide a continuous pattern or to fit adjoining construction, cut units with motor-driven saws; provide clean, sharp, unchipped edges. Allow units to dry before laying unless wetting of units is specified. Install cut units with cut surfaces and, where possible, cut edges concealed.
- E. Select and arrange units for exposed unit masonry to produce a uniform blend of colors and textures.
- F. Comply with construction tolerances in ACI 530.1/ASCE 6/TMS 602 and with the following:
1. For conspicuous vertical lines, such as external corners, door jambs, reveals, and expansion and control joints, do not vary from plumb by more than 1/8 inch in 10 feet maximum.
 2. For vertical alignment of exposed head joints, do not vary from plumb by more than 1/4 inch in 10 feet maximum.
 3. For conspicuous horizontal lines, such as lintels, sills, parapets, and reveals, do not vary from level by more than 1/8 inch in 10 feet maximum.

3.3 LAYING MASONRY WALLS

- A. Lay out walls in advance for accurate spacing of surface bond patterns with uniform joint thicknesses and for accurate location of openings, movement-type joints, returns, and offsets. Avoid using less-than-half size units, particularly at corners, jambs, and, where possible, at other locations.
- B. Bond Pattern for Exposed Masonry: Unless otherwise indicated, lay exposed masonry in running bond; do not use units with less than nominal 4-inch horizontal face dimensions at corners or jambs.
- C. Lay concealed masonry with all units in a wythe in running bond or bonded by lapping not less than 4 inches. Bond and interlock each course of each wythe at corners. Do not use units with less than nominal 4-inch horizontal face dimensions at corners or jambs.
- D. Stopping and Resuming Work: Stop work by racking back units in each course from those in course below; do not tooth. When resuming work, clean masonry surfaces that are to receive mortar, remove loose masonry units and mortar, and wet brick if required before laying fresh masonry.
- E. Built-in Work: As construction progresses, build in items specified in this and other Sections. Fill in solidly with masonry around built-in items.
- F. Fill space between steel frames and masonry solidly with mortar, unless otherwise indicated.
- G. Where built-in items are to be embedded in cores of hollow masonry units, place a layer of metal lath, wire mesh, or plastic mesh in the joint below and rod mortar or grout into core.
- H. Fill cores in hollow concrete masonry units with grout 24 inches under bearing plates, beams, lintels, posts, and similar items, unless otherwise indicated.
- I. Build non-load-bearing interior partitions full height of story to underside of solid floor or roof structure above, unless otherwise indicated.
1. Install compressible filler in joint between top of partition and underside of structure above.
 2. Fasten partition top anchors to structure above and build into top of partition. Grout cells of CMUs solidly around plastic tubes of anchors and push tubes down into grout to provide 1/2-inch clearance between end of anchor rod and end of tube. Space anchors 48 inches o.c., unless otherwise indicated.
 3. Wedge non-load-bearing partitions against structure above with small pieces of tile, slate, or metal. Fill joint with mortar after dead-load deflection of structure above approaches final position.
 4. At fire-rated partitions, treat joint between top of partition and underside of structure above to comply with Division 7 Section "Fire-Resistive Joint Systems."

3.4 MORTAR BEDDING AND JOINTING

A. Lay hollow concrete masonry units as follows:

1. With face shells fully bedded in mortar and with head joints of depth equal to bed joints.

B. Tool exposed joints slightly concave when thumbprint hard, using a jointer larger than joint thickness, unless otherwise indicated.

C. Cut joints flush for masonry walls to receive plaster or other direct-applied finishes (other than paint), unless otherwise indicated.

3.5 MASONRY JOINT REINFORCEMENT

A. General: Install entire length of longitudinal side rods in mortar with a minimum cover of 5/8 inch on exterior side of walls, 1/2 inch elsewhere. Lap reinforcement a minimum of 6 inches.

1. Space reinforcement not more than 16 inches o.c.

B. Interrupt joint reinforcement at control and expansion joints, unless otherwise indicated.

C. Provide continuity at wall intersections by using prefabricated T-shaped units.

D. Provide continuity at corners by using prefabricated L-shaped units.

E. Cut and bend reinforcing units as directed by manufacturer for continuity at [corners,] returns, offsets, column fireproofing, pipe enclosures, and other special conditions.

3.6 ANCHORING MASONRY TO STRUCTURAL MEMBERS

A. Anchor masonry to structural members where masonry abuts or faces structural members to comply with the following:

1. Provide an open space not less than 1/2 inch in width between masonry and structural member, unless otherwise indicated. Keep open space free of mortar and other rigid materials.

2. Anchor masonry to structural members with anchors embedded in masonry joints and attached to structure.

3. Space anchors as indicated, but not more than 24 inches o.c. vertically.

3.7 ANCHORING MASONRY VENEERS

A. Anchor masonry veneers to masonry backup with masonry-veneer anchors to comply with the following requirements:

1. Locate anchor sections to allow maximum vertical differential movement of ties up and down.

2. Space anchors as indicated, but not more than 16 inches o.c. vertically and 16 inches o.c. horizontally with not less than 1 anchor for each 1.77 sq. ft. of wall area. Install additional anchors within 12 inches of openings and at intervals, not exceeding 36 inches, around perimeter.

3.8 CONTROL AND EXPANSION JOINTS

A. General: Install control and expansion joint materials in unit masonry as masonry progresses. Do not allow materials to span control and expansion joints without provision to allow for in-plane wall or partition movement.

B. Form control joints in concrete masonry as follows:

1. Install preformed control-joint gaskets designed to fit standard sash block.

3.9 LINTELS

A. Install steel lintels where indicated or required.

B. Provide masonry lintels where shown and where openings of more than 24 inches are shown without structural steel or other supporting lintels.

C. Provide minimum bearing of 8 inches at each jamb, unless otherwise indicated.

3.10 REINFORCED UNIT MASONRY INSTALLATION

A. Temporary Formwork and Shores: Construct formwork and shores as needed to support reinforced masonry elements during construction.

1. Construct formwork to provide shape, line, and dimensions of completed masonry as indicated. Make forms sufficiently tight to prevent leakage of mortar and grout. Brace, tie, and support forms to maintain position and shape during construction and curing of reinforced masonry.

2. Do not remove forms and shores until reinforced masonry members have hardened sufficiently to carry their own weight and other temporary loads that may be placed on them during construction.

B. Placing Reinforcement: Comply with requirements in ACI 530.1/ASCE 6/TMS 602.

C. Grouting: Do not place grout until entire height of masonry to be grouted has attained enough strength to resist grout pressure.

1. Comply with requirements in ACI 530.1/ASCE 6/TMS 602 for cleanouts and for grout placement, including minimum grout space and maximum pour height.

2. Limit height of vertical grout pours to not more than 60 inches.

3.11 REPAIRING, POINTING, AND CLEANING

A. Remove and replace masonry units that are loose, chipped, broken, stained, or otherwise damaged or that do not match adjoining units. Install new units to match adjoining units; install in fresh mortar, pointed to eliminate evidence of replacement.

B. Pointing: During the tooling of joints, enlarge voids and holes, except weep holes, and completely fill with mortar. Point up joints, including corners, openings, and adjacent construction, to provide a neat, uniform appearance. Prepare joints for sealant application, where indicated.

C. In-Progress Cleaning: Clean unit masonry as work progresses by dry brushing to remove mortar fins and smears before tooling joints.

D. Final Cleaning: After mortar is thoroughly set and cured, clean exposed masonry as follows:

1. Remove large mortar particles by hand with wooden paddles and nonmetallic scrape hoes or chisels.
2. Test cleaning methods on sample wall panel; leave one-half of panel uncleaned for comparison purposes. Obtain GC's approval of sample cleaning before proceeding with cleaning of masonry.
3. Protect adjacent stone and non-masonry surfaces from contact with cleaner by covering them with liquid strippable masking agent or polyethylene film and waterproof masking tape.
4. Wet wall surfaces with water before applying cleaners; remove cleaners promptly by rinsing surfaces thoroughly with clear water.
5. Clean masonry with a proprietary acidic cleaner applied according to manufacturer's written instructions.
6. Clean concrete masonry by cleaning method indicated in NCMA TEK 8-2A applicable to type of stain on exposed surfaces.

3.12 MASONRY WASTE DISPOSAL

A. Salvageable Materials: Unless otherwise indicated, excess masonry materials are Contractor's property.

At completion of unit masonry work, remove from Project site.

PART 1 GENERAL**1.01 SECTION INCLUDES**

- A. Architectural cast stone.
- B. Units required are:
 - 1. Exterior wall units, including sills and other items as indicated.

1.02 RELATED REQUIREMENTS

- A. Section 04 2000 - Unit Masonry: Installation of cast stone in conjunction with masonry.
- B. Section 07 9200 - Joint Sealants: Sealing joints indicated to be left open for sealant.

1.03 REFERENCE STANDARDS

- A. ACI 318 - Building Code Requirements for Structural Concrete and Commentary; 2011.
- B. ASTM A615/A615M - Standard Specification for Deformed and Plain Carbon Steel Bars for Concrete Reinforcement; 2015.
- C. ASTM A767/A767M - Standard Specification for Zinc-Coated (Galvanized) Steel Bars for Concrete Reinforcement; 2009.
- D. ASTM A884/A884M - Standard Specification for Epoxy-Coated Steel Wire and Welded Wire Reinforcement; 2014.
- E. ASTM A1064/A1064M - Standard Specification for Carbon-Steel Wire and Welded Wire Reinforcement, Plain and Deformed, for Concrete; 2015.
- F. ASTM C33/C33M - Standard Specification for Concrete Aggregates; 2013.
- G. ASTM C150/C150M - Standard Specification for Portland Cement; 2015.
- H. ASTM C270 - Standard Specification for Mortar for Unit Masonry; 2014a.
- I. ASTM C494/C494M - Standard Specification for Chemical Admixtures for Concrete; 2013.
- J. ASTM C979/C979M - Standard Specification for Pigments for Integrally Colored Concrete; 2010.
- K. ASTM C1364 - Standard Specification for Architectural Cast Stone; 2016.

1.04 SUBMITTALS

- A. See Section 01 3000 - Administrative Requirements, for submittal procedures.
- B. Product Data: Test results of cast stone components made previously by the manufacturer.
- C. Shop Drawings: Include elevations, dimensions, layouts, profiles, cross sections, reinforcement, exposed faces, arrangement of joints, anchoring methods, anchors, and piece numbers.
- D. Mortar Color Selection Samples.
- E. Verification Samples: Pieces of actual cast stone components not less than 6 inches (152 mm) square, illustrating range of color and texture to be anticipated in components furnished for the project.

1.05 QUALITY ASSURANCE

- A. Manufacturer Qualifications:
 - 1. A firm with a minimum of 5 years' experience producing cast stone of types required for project.
 - 2. Adequate plant capacity to furnish quality, sizes, and quantity of cast stone required without delaying progress of the work.
- B. Mock-Up: Provide full size cast stone components for installation in mock-up of exterior wall.
 - 1. Approved mock-up will become standard for appearance and workmanship.
 - 2. Mock-up may not remain as part of the completed work.
 - 3. Remove mock-up not incorporated into the work and dispose of debris.

1.06 DELIVERY, STORAGE, AND HANDLING

- A. Deliver cast stone components secured to shipping pallets and protected from damage and discoloration. Protect corners from damage.
- B. Number each piece individually to match shop drawings and schedule.
- C. Store cast stone components and installation materials in accordance with manufacturer's instructions.
- D. Store cast stone components on pallets with nonstaining, waterproof covers. Ventilate under covers to prevent condensation. Prevent contact with dirt.
- E. Protect cast stone components during handling and installation to prevent chipping, cracking, or other damage.
- F. Store mortar materials where contamination can be avoided.
- G. Schedule and coordinate production and delivery of cast stone components with unit masonry work to optimize on-site inventory and to avoid delaying the work.

PART 2 PRODUCTS**2.01 MANUFACTURERS**

- A. Architectural Cast Stone: All cast stone shall be provided by a single manufacturer.
1. Reading Rock.
 2. Heritage Cast Stone, Inc.
 3. Arriscraft.
 4. Gage Brothers Concrete Products, Inc.
 5. American Artstone.
 6. Stoneworks Architectural Precast.
 7. Substitutions: See Section 01 6000 - Product Requirements.

2.02 ARCHITECTURAL CAST STONE

- A. Cast Stone <CAST STN-1>: Architectural concrete product manufactured to simulate appearance of natural limestone, complying with ASTM C1364.
1. Compressive Strength: As specified in ASTM C1364; calculate strength of pieces to be field cut at 80 percent of uncut piece.
 2. Freeze-Thaw Resistance: Demonstrated by laboratory testing in accordance with ASTM C1364.
 3. Finish: Acid etched, medium finish.
 4. Basis of Design: ReadingRock; Rockcast; Charlotte Tan.
 5. Remove cement film from exposed surfaces before packaging for shipment.
 6. For locations too large for a single cast stone unit, coordinate joint locations with Architect.
- B. Shapes: Provide shapes indicated on drawings.
1. Variation from Any Dimension, Including Bow, Camber, and Twist: Maximum of plus/minus 1/8 inch (3 mm) or length divided by 360, whichever is greater, but not more than 1/4 inch (6 mm).
 2. Unless otherwise indicated on drawings, provide:
 - a. Wash or slope of 1:12 on exterior horizontal surfaces.
 - b. Drips on projecting components, wherever possible.
 - c. Raised fillets at back of sills and at ends to be built in.
- C. Reinforcement: Provide reinforcement as required to withstand handling and structural stresses; comply with ACI 318.

2.03 MATERIALS

- A. Portland Cement: ASTM C150/C150M.
1. For Units: Type I, white or gray as required to match Architect 's sample.
 2. For Mortar: Type I or II, except Type III may be used in cold weather.
- B. Coarse Aggregate: ASTM C33/C33M, except for gradation; granite, quartz, or limestone.
- C. Fine Aggregate: ASTM C33/C33M, except for gradation; natural or manufactured sands.
- D. Pigments: ASTM C979, inorganic iron oxides; do not use carbon black.
- E. Admixtures: ASTM C494/C494M.
- F. Water: Potable.
- G. Reinforcing Bars: ASTM A615/A615M deformed bars, galvanized.
1. Galvanized in accordance with ASTM A767/A767M, Class I.
- H. Steel Welded Wire Reinforcement: ASTM A1064/A1064M, galvanized or ASTM A884/A884M, epoxy coated.
1. Embedded Anchors, Dowels, and Inserts: Type 304 stainless steel, of type and size as required for conditions.
- J. Mortar: Portland cement-lime, as specified in Section 04 2000.
- K. Cleaner: General-purpose cleaner designed for removing mortar and grout stains, efflorescence, and other construction stains from new masonry surfaces without discoloring or damaging masonry surfaces; approved for intended use by cast stone manufacturer and by cleaner manufacturer for use on cast stone and adjacent masonry materials.

PART 3 EXECUTION**3.01 EXAMINATION**

- A. Examine construction to receive cast stone components. Notify Architect if construction is not acceptable.
- B. Do not begin installation until unacceptable conditions have been corrected.

3.02 INSTALLATION

- A. Install cast stone components in conjunction with masonry, complying with requirements of Section 042000.
- B. Mechanically anchor cast stone units indicated; set remainder in mortar.
- C. Setting:
1. Drench cast stone components with clear, running water immediately before installation.
 2. Set units in a full bed of mortar unless otherwise indicated.
 3. Fill vertical joints with mortar.
 4. Fill dowel holes and anchor slots completely with mortar or non-shrink grout.
- D. Joints: Make all joints 3/8 inch (9.5 mm), except as otherwise detailed.
1. Rake mortar joints 3/4 inch (19 mm) for pointing.
 2. Remove excess mortar from face of stone before pointing joints.
 3. Point joints with mortar in layers 3/8 inch (9.5 mm) thick and tool to a slight concave profile.
 4. Leave the following joints open for sealant:
 - a. Head joints in top courses, including copings, parapets, cornices, sills, and steps.
 - b. Joints in projecting units.
 - c. Joints between rigidly anchored units, including soffits, panels, and column covers.
 - d. Joints below lugged sills and stair treads.
 - e. Joints below ledge and relieving angles.
 - f. Joints labeled "expansion joint".
- E. Installation Tolerances:
1. Variation from Plumb: Not more than 1/8 inch in 10 feet (3 mm in 3 m) or 1/4 inch in 20 feet (6mm in 6 m) or more.
 2. Variation from Level: Not more than 1/8 inch in 10 feet (3 mm in 3 m) or 1/4 inch in 20 feet (6mm in 6 m), or 3/8 inch (9 mm) maximum.
 3. Variation in Joint Width: Not more than 1/8 inch in 36 inches (3 mm in 900 mm) or 1/4 of nominal joint width, whichever is less.
 4. Variation in Plane Between Adjacent Surfaces (Lipping): Not more than 1/16 inch (1.5 mm) difference between planes of adjacent units or adjacent surfaces indicated to be flush with units.
- F. Repairs: Repair chips and other surface damage noticeable when viewed in direct daylight at 20 feet (6m).
1. Repair with matching touchup material provided by the manufacturer and in accordance with manufacturer's instructions.
 2. Repair methods and results subject to Architect 's approval.

3.03 CLEANING

- A. Keep cast stone components clean as work progresses.

3.04 PROTECTION

- A. Protect completed work from damage.
- B. Clean, repair, or restore damaged or mortar-splashed work to condition of new work.

STRUCTURAL STEEL

PART 1 - GENERAL

1.1 SUMMARY

- A. Furnish all labor and materials to complete structural metal as indicated on the drawings and/or as specified herein, including base plates, setting plates, tie rods and bars, all connections required by poured-in-place concrete that are indicated shop connected to structural metal.
- B. Anchor bolts, other incidental items of structural metal required to be built into concrete or masonry shall be furnished to respective trades at proper time, including instruction and templates for their installation.
- C. Provide shop drawings to the General Contractor or Owner for approval.

PART 2 - PRODUCTS

2.1 MATERIALS

- A. Structural steel: ASTM A36. Furnish mill certificate for all A36 steel, as required by the Engineer/Architect.
- B. Arc welding electrodes: American Welding Society "Iron and Steel Arc Welding Electrodes" E60 and E70 series.
- C. Bolts: High strength bolts, ASTM A325.
- D. Fabrication
 - 1. Welding: Appearance, quality of weld, methods of correcting defective work shall be AWS "Code for ARC Welding in Building Construction".
 - 2. Holes for all bolts shall be 1/16" larger than external diameter of bolt. Holes for bolts inserted in shop may be drilled from solid or punched and reamed. Holes for bolts inserted in field shall be sub-punched in shop, reamed in field. Perform all drilling, reaming for turned bolts after parts to be connected are assembled. Provide bolt holes as required for erection; wood blocking special bolt holes as indicated.
- E. Shop Painting
 - 1. Remove all rust, mill scale and other foreign materials prior to painting.
 - 2. All structural metal shall be shop primed with structural metal primer. Primer shall meet FS TT-P-636-C with a [pigment composition of not less than 50% iron oxide, not less than 10% zinc chromate and not more than 30% silica silicates and calcium carbonates. The non-volatile portion of the vehicle shall be medium oil-alkyd, 30% phallic anhydride with viscosity between 57% and 67%. Brand: Lindsay's "Zinc Kote" , Tnemec #99-G, or approved equal.
 - 3. Field touch-up all exposed steel with metal primer to prevent rusting.

PART 3 - EXECUTION

- A. Provide loose steel lintels over exterior and interior openings as indicated. Bear 6" unless otherwise indicated. Check all drawings and specifications for lintels required over doors, ventilators, grilles, etc. Provide all angles, lintels, etc. as required for all built-in items, openings, whether indicated or not.

PART 1 - GENERAL**1.1 RELATED DOCUMENTS**

A. Conditions of the Contract and portions of Division One of this Project Manual apply to this Section.

1.2 SECTION INCLUDES

A. This section includes all labor, material, equipment, and related services necessary to furnish and install all metal fabrications indicated on the drawings or specified herein.

B. The work of this section includes, but is not limited to:

1. Sleeves
2. Loose and field welded lintels and support angles
3. As indicated or required

1.3 RELATED SECTIONS

A. Section 03300- CAST-IN –PLACE CONCRETE for concrete fill for pipe bollards.

B. Section 05100- STRUCTURAL STEEL for structural-steel framing systems components and metal handrails.

C. Section 06200- FINISH CARPENTRY for wood handrails.

D. Section 09900- PAINTING

E. Section 10800- MICELLANEOUS SPECIALTIES for toilet and bathroom accessory requirements of sheet metal wall blocking.

1.4 SUBMITTALS

A. Submit in accord with Section 01 33 00.

1. Shop drawings required for all items. Show all work to be fabricated with all construction details shown in appropriate scale, methods of attachments to other materials, finished dimensions, shop welds and grinding of welds, field assembly joints, etc.
2. Coordinate work with other suppliers and subcontractors; obtain their approved shop drawing where necessary, or obtain any necessary additional detail information regarding mounting conditions or other aspects of related work.

1.5 QUALITY ASSURANCE

A. Take field measurements prior to shop drawing preparation and fabrications.

B. Comply with the provisions of the following except as otherwise indicated:

1. AISC "Code of Standard Practice for Steel Buildings and Bridges".
2. AISC "Specifications for the Design, Fabrication, and Erection of Structural Steel for Buildings", including the "Commentary" and Supplements thereto as issued.
3. AISC "Specifications for Structural Joints using ASTM A 325 or A 490 Bolts" approved by the Research Council on Riveted and Bolted Structural Joints of the Engineering Foundation.
4. AWS D1.1 "Structural Welding Code".
5. AASHTO M180 "Corrugated Sheet Steel Beams for Highway Construction".

C. Qualify welding process and welding operators in accordance with the AWS "Standard Qualification Procedure".

Provide certification that welders to be employed in the work have satisfactorily passed AWS qualification tests within the previous twelve months. If recertification of welders is required, retesting will be the Contractor's responsibility.

D. Structural Performances

1. Treads and platforms shall be capable of withstanding a uniform load of 100 lbs. per sq. ft. or a concentrated load of 300 lbs. located to produce maximum stress conditions.
2. Handrails and top rails shall be capable of withstanding concentrated loads of 200 lbs. applied at any point in any direction or a uniform load of 50 lbs/ft applied horizontally at the top rail, whichever produces the greatest stress.

E. Preassemble items in shop to greatest extent possible to minimize field splicing and assembly.

Disassemble units only as necessary for shipping and handling limitations. Clearly mark units for

PART 2 - PRODUCTS**2.1 MATERIALS**

A. Structural steel: ASTM A36. Furnish mill certificate for all A36 steel, as required by the Engineer/Architect.

B. Arc welding electrodes: American Welding Society "Iron and Steel Arc Welding Electrodes" E60 and E70 series.

C. Bolts: High strength bolts, ASTM A325. Holes for all bolts shall be 1/16" larger than external diameter of bolt.

D. Fabrication: Welding: Appearance, quality of weld, methods of correcting defective work shall be AWS "Code for ARC Welding in Building Construction".

E. This section includes:

1. Loose steel lintels, bearing the leveling plates, miscellaneous framing and supports
2. Pipe Bollards
3. Exterior Railings at Stairs, Ramps, Walks, and Balconies; to be aluminum powder coated, custom fabricated.

PART 2 - PRODUCTS**2.1 MATERIALS**

- D. Metals, General
1. Metal Surfaces, General: For metal fabrications exposed to view in the completed Work, provide materials with smooth, flat surfaces without blemishes. Do not use materials with exposed pitting, seam marks, roller marks, roller trade names, or roughness.
 2. Steel Tubing: Product Type (manufacturing method) as follows:
 - a. Cold-formed steel tubing complying with ASTM A 500.
 - b. Hot-formed steel tubing complying with ASTM A 501.
 3. Steel Pipe: ASTM A 53, standard weight (Schedule 40), unless another weight is indicated or required by structural loads.
 4. Malleable-Iron Casting: ASTM A 47, Grade 32510.
- E. Cast-in-place anchors in concrete: anchors of type indicated below, fabricated from corrosion-resistant materials capable of sustaining, without failure, the load imposed within a safety factor of 4, as determined by testing per ASTM E 488, conducted by a qualified independent testing agency.
1. Threaded or wedge type: galvanized ferrous casting, either ASTM A 47 malleable iron or ASTM A 27 cast steel.
 2. Provide bolts, washers, and shims as needed, hot-dip galvanized per ASTM A 153.
- F. Welding Rods and Bare Electrodes: Select according to AWS specifications for metal alloy welded.
- G. Paint
1. Shop Primers: Provide primers that comply with Section 09900-PAINTING
 2. Shop Primer for Ferrous Metal: Organic zinc-rich primer, complying with SSPC-Paint 20 and compatible with topcoat.
 3. Galvanizing repair paint: High-zinc-dust-content paint for re-galvanizing welds in steel, complying with SSPC-Paint 20.
 4. Bituminous Paint: Cold-applied asphalt mastic complying with SSPC-Paint 12, except containing no asbestos fibers, or cold-applied asphalt emulsion complying with ASTM D 1187.
- H. Fasteners
1. General: Provide Type 304 or 316 stainless-steel fasteners with coating complying with ASTM B 633, Class Fe/Zn 5, where built into exterior walls. Select fasteners for type, grade, and class required.
 2. Anchor Bolts: ASTM F 1554, Grade 36.
 3. Machine Screws: ASME B18.6.3.
 4. Lag Bolts: ASME B18.2.1.
 5. Wood Screws: Flat head, carbon steel, ASME B18.6.1.
 6. Plain Washers: Round, carbon steel, ASME B18.22.1
 7. Lock Washers: Helical, spring type, carbon steel, ASME B18.21.1.
 8. Expansion Anchors: Anchor bolt and sleeve assembly of material indicated below with capability to sustain, without failure, a load equal to six times the load imposed when installed in concrete, as determined by testing per ASTM E 488, conducted by a qualified independent testing agency.
Material: Alloy Group 1 or 2 stainless-steel bolts complying with ASTM F 594.
 9. Toggle Bolts: FS FF-B-588, tumble-wing type, class and style as needed.
- I. Grout
1. Non-shrink, nonmetallic grout: Factory packaged, non-staining, noncorrosive, nongaseous grout complying with ASTM C 1107. Provide grout specifically recommended by manufacturer for interior and exterior applications.
- J. Concrete Fill
1. Concrete Materials and Properties: Comply with requirements in Section 03300-CAST-IN-PLACE CONCRETE for normal-weight, air-entrained, ready-mix concrete with a minimum 28-day compressive strength of 300psi, unless otherwise indicated.

2.1 MATERIALS

- K. Fabrication, General
1. Shop Assembly: Preassemble items in shop to greatest extent possible to minimize field splicing and assembly. Disassemble units only as necessary for shipping and handling limitations. Use connections that maintain structural value of joined pieces. Clearly mark units for reasonably and coordinated installation.
 2. Shear and punch metals cleanly and accurately. Remove burrs.
 3. Ease exposed edges to a radius of approximately 1/32inch, unless otherwise indicated. Form bent-metal corners to smallest radius possible without causing grain separation or otherwise impairing work.
 4. Weld corners and seams continuously to comply with the following:
 - a. Use materials and methods that minimize distortions and develop strength and corrosion resistance of base metals.
 - b. Obtain fusion without undercut or overlap.
 - c. Remove welding flux immediately
 - d. At exposed connections, finish exposed welds and surfaces smooth and blended so no roughness shows after finishing and contour of welded surface matches that of adjacent surface.
 5. Provide for anchorage of type indicated; coordinate with supporting structure. Fabricate and space anchoring devices to secure metal fabrications rigidly in place and to support indicated loads.
 6. Cut, reinforce, drill, and tap metal fabrications as indicated to receive finish hardware, screws, and similar items.
 7. Fabrication joints that will be exposed to weather in a manner to exclude water, or provide weep holes where water may accumulate.
 8. Allow for thermal movement resulting from the following maximum change (range) in ambient and surface temperature by preventing buckling, opening of joints, overstressing of components, failure of connections, and other detrimental effects. Base engineering calculation on surface temperatures of materials due to both solar heat gain and nighttime –sky heat loss.
 9. Form exposed work true to line and level with accurate angles, surfaces and straight sharp edges.
 10. Remove sharp or rough areas on exposed traffic surfaces. Form exposed connections with hairline joints, flush and smooth, using concealed fasteners where possible. Use exposed fasteners to type indicated or, if not indicated, Phillips flat-head (countersunk) screws or bolts. Locate joints where least conspicuous.
- L. Steel and Iron Finishes
1. Galvanizing: Hot-dip galvanized items as indicated to comply with applicable standard listed below:
 - a. ASTM A 123, for galvanizing steel and iron products.
 - b. ASTM A 153, for galvanizing steel and iron hardware.
 2. Preparation for Shop Priming: Prepare uncoated ferrous-metal surface to comply with minimum requirements indicated below for SSPC surface-preparation specifications and environmental exposure conditions of installed metal fabrications:
 - a. Exteriors (SSPC Zone 1 B): SSPC-SP 6/NACE No. 3, “Commercial Blast Cleaning”.
 - b. Interiors (SSPC Zone 1 A): SSPC-SP 3, “Power Tool Cleaning.”
 3. Apply shop primer to uncoated surfaces of metal fabrications, except those with galvanized finishes and those to be embedded in concrete, sprayed-on fireproofing, or masonry, unless otherwise indicated. Comply with SSPC-PA 1, “Paint Application Specification No. 1,” for shop painting.
 - a. Stripe paint corners, crevices, bolts, welds, and sharp edges.

PART 3 - EXECUTION**3.1 INSTALLATION**

- A. Anchor to masonry with expansion bolts or toggle bolts. Where built-in anchorage is not provided do not use wood plugs.
- B. Cutting, Fitting, and Placement: Perform cutting, drilling, and fitting required for installing metal fabrications. Set metal fabrications accurately in location, alignment, and elevation; with edges and surfaces level, plumb, true, and free or rack.
- C. Provide temporarily bracing or anchors in formwork for items that are to be built into concrete, masonry, or similar construction.
- D. Fit exposed connections accurately together to from hairline joints. Weld connections accurately that are not to be left as exposed joints but cannot be shop welded because of shipping size limitations. Do not weld, cut, or abrade surfaces of exterior units that have been hot-dip galvanized after fabrication and are for bolted or screwed field connections.
- E. Bolts, screws, and similar fastenings for field connections shall be of the same material and finish as the parts being fastened, in accordance with the manufacturer's instructions and approved shop drawings.
- F. Immediately after erection, repaint field connections, weld burns, abraded surfaces. Scrape and wire brush loose and scaling paint to sound metal, follow with spot priming specified in Section 09900 -Painting.

PART 1 - GENERAL

1.1 SUMMARY

A. Section Includes:

1. Structural dimension lumber framing
2. Engineered structural framing members
3. Built-up structural members.
4. Wall, roof, and floor sheathing.
5. Preservative treated wood materials.
6. Miscellaneous framing and sheathing.
7. Communications and electrical room mounting boards.
8. Concealed wood blocking, nailers, and supports.
9. Miscellaneous wood nailers, furring, and grounds.
10. Wood construction connectors.

B. Related Sections:

1. Division 01: Administrative, procedural, and temporary work requirements.

1.2 REFERENCES

A. ASTM International (ASTM):

1. A153 - Standard Specification for Zinc-Coating (Hot Dip) on Iron and Steel Hardware.
2. ASTM E 84 – Standard Test Method for Surface Burning Characteristics of Building Materials, 2008

B. Code and Design References:

1. ANSI/AF&PA – National Design Specification for Wood Construction, 2005 Edition
2. AF&PA – Manual for Engineered Wood Construction, 2005 Edition
3. ANSI/AF&PA – Special Design Provisions for Wind and Seismic, 2005 Edition
4. DOC PS 20-05 American Softwood Lumber Standard
5. DOC PS 1-07 Construction and Industrial Plywood
6. DOC PS 2-04 Performance Standard for Wood-Based Structural Use Panels
7. ANSI A208.1-99 – Particleboard
8. APA PRP-108 – Composite and OSB Panels

C. Grading Agencies:

1. Wood Structural Panel Grading Agency: APA – The Engineered Wood Association
2. Lumber Grading Agency: AITC – American Institute of Timber Construction
3. WWPA – Western Wood Products Association
4. SPIB – Southern Pine Inspection Bureau
5. NLGA – National Lumber Grades Authority
6. WCLIB – West Coast Lumber Inspection Bureau

D. Wood Construction Connectors:

1. Reference approved supplier's specifications.

E. Engineered Structural Framing members:

1. Reference approved supplier's specifications.

1.3 SUBMITTALS

A. Submittals for Review:

1. Product Data: Provide technical data on insulated sheathing, wood preservative materials and application instructions.
2. Manufacturer's Certificate: Certify that wood products supplied for rough carpentry meet or exceed specified requirements.
Alternative materials must be submitted for approval from Structural Engineer prior to fabrication/installation.

1.4 QUALITY ASSURANCE

A. Installer Qualifications: Use adequate numbers of skilled workmen who are thoroughly trained and experienced in the necessary crafts and who are completely familiar with the specified requirements and the methods needed for proper performance of the work in this section.

B. Listing and Labeling:

1. Grade Stamps: Provide lumber with each piece factory marked with grade stamp of inspection agency evidencing compliance with grade rule requirements and indentifying grading agency, grade, species, moisture content at time of surfacing, and mill.

1.5 DELIVERY, STORAGE AND HANDLING

- A. General: Cover wood products to protect against moisture. Support stacked products to prevent deformation and to allow air circulation.
- B. Fire Retardant Treated Wood: Prevent exposure to precipitation during shipping, storage or installation.
- C. Material Safety Data sheets shall be provided by all material suppliers upon being awarded the contract.
- D. **Material deliveries are to be coordinated with the General Contractor or Owner prior to shipping** to ensure proper off-loading procedures are arranged.

PART 2 – PRODUCTS

2.1 MANUFACTURERS

- A. Acceptable Manufacturers – Engineering Lumber products:
 - 1. I-Level by Weyerhaeuser www.weyerhaeuser.com.
 - 2. Boise Cascade: www.bc.com.
 - 3. Georgia-Pacific Corp.: www.buildgp.com.
 - 4. Substitutions: See Section 01 6000 - Product Requirements.
- B. Acceptable Manufacturers – Wood Construction Connectors:
 - 1. Simpson Strong-Tie
 - 2. USP Structural Connectors
- C. Substitutions: Under provisions of Division 01.

2.2 GENERAL REQUIREMENTS

- A. Dimension Lumber: Comply with PS 20 and requirements of specified grading agencies.
 - 1. Species: Spruce-Pine-Fir (South), unless otherwise indicated.
 - 2. If no species is specified, provide any species graded by the agency specified; if no grading agency is specified, provide lumber graded by any grading agency meeting the specified requirements.
 - 3. Grading Agency: Any grading agency whose rules are approved by the Board of Review, American Lumber Standard Committee (www.alsc.org) and who provides grading service for the species and grade specified; provide lumber stamped with grade mark unless otherwise indicated.
- B. Lumber fabricated from old growth timber is not permitted.

2.3 MATERIALS

- A. Structural Composite Lumber: Comply with DOC PS 20 and requirements of specified grading agencies. Factory fabricated beams, headers, and columns, of sizes and types indicated on drawings; structural capacity as published by manufacturer.
 - 1. Wall studs
 - a. Species: See Structural Drawings
 - b. Grading Agency: Provide lumber stamped with grade mark by approved grading agency
 - c. Sizes: Nominal sizes as indicated on drawings, S4S.
 - d. Moisture Content: Kiln dry or MC15
 - 2. Beams, columns and plates:
 - a. Species: See Structural drawings.
 - b. Grading Agency: Provide lumber stamped with grade mark by approved grading agency
 - c. Sizes: Nominal sizes as indicated on drawings, S4S.
 - d. Moisture Content: Kiln dry or MC15
 - e. LBL Beams: by Trus Joist Corporation or equal. Glue shall meet wet service conditions.
Appearance shall be industrial grade with surfaces not sealed except for ends.
 - 3. Engineered Lumber products:
 - a. Species: Supplier to provide material to meet or exceed material specification on Structural drawings.
 - b. Sizes: As indicated on drawings
 - 4. Miscellaneous Framing:
 - a. Species: SPF #1/#2, unless otherwise noted on Structural Drawings.
 - b. Grading Agency: Provide lumber stamped with grade mark by approved grading agency
 - c. Sizes: Nominal sizes as indicated on drawings, S4S.
 - d. Moisture Content: Kiln dry or MC15

2.4 DIMENSION LUMBER FOR CONCEALED APPLICATIONS

- A. Grading Agency: Southern Pine Inspection Bureau, Inc; SPIB (GR).
- B. Sizes: Nominal sizes as indicated on drawings, S4S.
- C. Moisture Content: S-dry or MC19.
- D. Stud Framing (2 by 2 through 2 by 6 (50 by 50 mm through 50 by 150 mm)):
 - 1. Species: Spruce-Pine-Fir.
 - 2. Grade: No. 2.
- E. Joist, Rafter, and Small Beam Framing (2 by 6 through 4 by 16 (50 by 150 mm through 100 by 400 mm)):
 - 1. Machine stress-rated (MSR) as follows:
 - a. Fb-single (minimum extreme fiber stress in bending): 1350 psi (9,300 kPa).
 - b. E (minimum modulus of elasticity): 1,300,000 psi (8960 MPa).
 - 2. Species: Spruce-Pine-Fir (South).
- F. Miscellaneous Framing, Blocking, Nailers, Grounds, and Furring <WD BLKG>:
 - 1. Lumber: S4S, No. 2 or Standard Grade.
 - 2. Boards: Standard or No. 3.

2.5 CONSTRUCTION PANELS

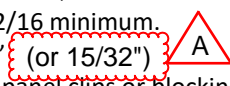
- A. General Wood Panel Products:
 - 1. Thickness: As needed to comply with requirements specified, but not less than thickness indicated.
 - 2. Factory mark panels to indicate compliance with applicable standards.
- B. Floor Sheathing <WD SHTG-1>: APA PRP-108, Rated Sturd-I-Floor, unless otherwise noted on drawings.
 - 1. Bond Classification: Exposure 1.
 - 2. Span Rating: 16.
 - 3. Edges: Tongue and groove.
 - 4. Thickness: 3/4 inch.
- C. Roof Sheathing <WD SHTG-14>: Oriented strand board wood structural panel; PS 2.
 - 1. Grade: Structural 1 Sheathing.
 - 2. Performance Category: 1/2 PERF CAT. with H-Clips.
- D. Wall Sheathing <WD SHTG-#>: Oriented strand board, PS 2, Structural I Rated Sheathing, Exterior Exposure Class, unless otherwise noted on drawings, and as follows:
 - 1. <WD SHTG-20>: 15/32 inch thick.
 - 2. <WD SHTG-24>: 3/4 inch thick.
- E. Fiberglass Reinforced Plastic (FRP) Panels <FRP PNL-10>:
 - 1. Product: P100 - Pebble Surface by Marlite FRP or approved equal.
 - 2. Color: As selected from manufacturer's full range.
 - 3. FRP Trim and Fasteners: Same color, finish, and manufacturer as FRP panel, provide all matching trim needed for installation of FRP panels.
 - 4. Application: Provide within 4 feet of mop sinks and other locations as indicated.
- F. Other Applications:
 - 1. Plywood Concealed From View But Located Within Exterior Enclosure: PS 1, C-C Plugged or better, Exterior grade.
 - 2. Plywood Exposed to View But Not Exposed to Weather: PS 1, A-D, or better.
 - 3. Other Locations: PS 1, C-D Plugged or better.
- G. Wood Sheathing: Comply with DOC PS 1-07 and DOC PS 2-04 requirements of specified grading agencies.
 - 1. Roof sheathing: APA PRP-108, Rated Sheathing, Exterior Exposure Class
 - a. Span Rating: 32/16 minimum.
 - b. Thickness: 1/2" (or 15/32") 
 - c. Edges: Provide panel clips or blocking per Structural drawings.
 - 2. Wall sheathing:
 - a. Span Rating: 24/16 minimum.
 - b. Thickness: 7/16"
 - c. Edges: Blocking at panel edges per Structural Drawings.
 - 3. Floor sheathing (AdvanTech):
 - a. Thickness: 3/4"
 - b. Edges: Blocking at panel edges per Structural Drawings.
 - 4. Communications and Electrical Room Mounting Boards: Plywood, Exposure I, C-D Plugged, fire-retardant treated, not less than 1/2" thick.
- H. Miscellaneous Lumber (Non-structural):
 - 1. Construction, Stud or No. #3 grade of any species for nailers and similar members.

I. Accessories:

1. Fasteners and Anchors: Size and type indicated on Structural drawings. Where rough carpentry is exposed to weather, in ground contact, or in area of high relative humidity, provide fasteners with hot-dip zinc coating complying by ASTM A153. Fasteners in contact with pressure treated lumber to be coated with shop approved coating to prevent corrosion of hardware.
 - a. Bolts: Steel bolts complying with ASTM A307, Grade A, with ASTM A563 hex nuts and where indicated, flat washers.
 - b. Anchors: As specified on structural drawings, hot-dip galvanized steel. All alternative anchors must be submitted to Structural Engineer for approval prior to installation.
2. Structural Framing Connectors, Joist Hangers: Galvanized steel, as specified on Structural Drawings. All alternative connectors must be submitted to Structural Engineer for approval prior to installation. Structural Framing Connectors in contact with pressure treated lumber to be coated with shop approved coating to prevent corrosion of hardware.
3. Sill Sealer on Top of Foundation Wall: Plate width, closed cell foam or glass fiber strip.
4. Winter Guard: Provide per roofing manufactures recommendations. A minimum of 24" past in side of plate line and at valleys – see roof plans.
5. Building Wrap: Air-retarder sheeting made from polyolefins; cross-laminated films, woven strands, or spun-bonded fibers, coated or uncoated; with or without perforations; and complying with ASTM E1677, Type I.
 - a. Products: Tyvek building wrap.

E. Treated Materials:

1. Preservative-Treated Materials: AWPA C2 lumber and AWPA C9 plywood, labeled by an inspection agency approved by ALSC's Board of Review. After treatment, kiln-dry lumber and plywood to 19 and 15 percent moisture content, respectively. Treat indicated items on the drawings and the following:
 - a. Wood members in connection with roofing, flashing, vapor barriers, and waterproofing.
 - b. Concealed members in contact with masonry or concrete
 - c. Wood framing members less than 18" above grade
 - d. Wood floor plates installed over concrete slabs/foundation directly in contact with soil.

2.6 ACCESSORIES**A. Fasteners and Anchors:**

1. Metal and Finish: Hot-dipped galvanized steel complying with ASTM A153/A153M for high humidity and preservative-treated wood locations, unfinished steel elsewhere.
 2. Drywall Screws: Bugle head, hardened steel, power driven type, length three times thickness of sheathing.
- B. Subfloor Glue:** Waterproof, air cure type, cartridge dispensed.
- C. Water-Resistive Barrier:** As specified in Section 07 2500.

2.7 FACTORY WOOD TREATMENT**A. Treated Lumber and Plywood:** Comply with requirements of AWPA U1 - Use Category System for wood treatments determined by use categories, expected service conditions, and specific applications.

1. Fire-Retardant Treated Wood: Mark each piece of wood with producer's stamp indicating compliance with specified requirements.
2. Preservative-Treated Wood: Provide lumber and plywood marked or stamped by an ALSC-accredited testing agency, certifying level and type of treatment in accordance with AWPA standards.

B. Fire Retardant Treatment:

1. Exterior Type: AWPA U1, Category UCFB, Commodity Specification H, chemically treated and pressure impregnated; capable of providing a maximum flame spread index of 25 when tested in accordance with ASTM E84, with no evidence of significant combustion when test is extended for an additional 20 minutes both before and after accelerated weathering test performed in accordance with ASTM D2898.
 - a. Kiln dry wood after treatment to a maximum moisture content of 19 percent for lumber and 15 percent for plywood.
 - b. Do not use treated wood in direct contact with the ground.
2. Interior Type A: AWPA U1, Use Category UCFA, Commodity Specification H, low temperature (low hygroscopic) type, chemically treated and pressure impregnated; capable of providing a maximum flame spread index of 25 when tested in accordance with ASTM E84, with no evidence of significant combustion when test is extended for an additional 20 minutes.
 - a. Kiln dry wood after treatment to a maximum moisture content of 19 percent for lumber and 15 percent for plywood.
 - b. Treat rough carpentry items as indicated.
 - c. Do not use treated wood in applications exposed to weather or where the wood may become wet.

C. Preservative Treatment:

1. Preservative Pressure Treatment of Lumber Above Grade: AWWA U1, Use Category UC3B, Commodity Specification A using waterborne preservative.
 - a. Kiln dry lumber after treatment to maximum moisture content of 19 percent.
2. Preservative Pressure Treatment of Plywood Above Grade: AWWA U1, Use Category UC2 and UC3B, Commodity Specification F using waterborne preservative.
 - a. Kiln dry plywood after treatment to maximum moisture content of 19 percent.
3. Preservative Pressure Treatment of Lumber in Contact with Soil: AWWA U1, Use Category UC4A, Commodity Specification A using waterborne preservative.
 - a. Preservative for Field Application to Cut Surfaces: As recommended by manufacturer of factory treatment chemicals for brush-application in the field.

PART 3 – EXECUTION

3.1 Framing Installation:

- A. Set structural members level, plumb and true to line. Discard pieces with defects that would lower required strength or result in unacceptable appearance of exposed members.
- B. Fasten and connect framing in accordance with Structural drawings.
- C. Comply with member sizes, spacing, and configurations indicated, and fasten size and spacing as indicated on Structural drawings.
- D. Make provisions for the temporary construction loads and provide temporary bracing sufficient to maintain structure in true alignment and safe condition until completion of erection and installation of permanent bracing.

E. Fire-Stopping and Misc. Framing:

1. Contractor shall familiarize himself with the location of all draft-stopping, mechanical chases, duct openings, and or framing required for other trades and include this work in their proposal
2. Provide in all walls, partitions, floors, stairs, attic, or cornice construction around chimneys, pipe, and duct openings to cut off all concealed draft openings – horizontal and vertical, to form an effective smoke and fire barrier as shown or implied on the drawings.
3. Materials shall be in accordance with all state and local governing codes.
4. Provide self-closing access panel openings in attic draft stops.

3.2 Sheathing Installation:

- A. Fasten sheathing in accordance with Structural drawings.
- B. Secure wall sheathing with ends staggered, over firm bearing.
- C. Secure roof and floor sheathing with panel long dimension perpendicular to framing members, ends staggered, over firm bearing.
- D. Provide proper cut outs for ventilation louvers as required

3.3 Blocking, Nailers, and supports Installation:

- A. Provide framing and blocking members as indicated on Structural drawings, instructed by GC, or as required to support finishes, fixtures, specialty items, and trim.
- B. Wood backing:
 1. Provide miscellaneous backing and framing as shown and as required for support of facing materials and trim.
 2. Backing shall be provided as shown on the drawings or as instructed by the General Contractor or Owner, for all mounted items and fixtures such as door bumpers, grab bars, drapery track, handrail brackets, cabinets etc. or as required for use by other trades as their work and materials dictate.
 3. Provide 2x6 (minimum) blocking securely attach to studding. Use scrap material for this purpose. DO NOT USE FULL LENGTH MATERIAL!
 4. OSB or plywood backing may be applied for this purpose over stud framing where sound channel is to be installed.
 5. OSB or plywood backing shall be installed over the drywall within the mechanical room for mounting of telephone and cable TV equipment.
 6. Sheetrock backing shall be installed in any location where the framing distance to any wall partition is greater than 6". This includes wall partitions and wall/ ceiling partitions.

3.4 Roof-Related Carpentry:

- A. Coordinate **installation** of roofing carpentry with deck construction, framing of roof openings, and roofing assembly installation
- B. Provide wood curb at all roof openings except where prefabricated curbs are specified and where specifically indicated otherwise. Form corners by alternating lapping side members.

3.5 Field Quality Control

A. Testing and Inspection Services:

- 1. Framing: Inspect framing to comply with Structural drawings and details.
- 2. Sheathing: Inspect fastening to comply with Structural drawings and details.
- 3. Hardware and Connectors: Inspect installation to comply with Structural drawings and details.
- 4. Inspection Agency to submit testing/inspection reports to Architect and Engineer.

B. Cleaning:

- 1. Keep job site clean of material scraps at all times.
- 2. Do not throw any dimensional lumber scrap into the dumpster that is over 24" in length. This material is to be set aside and used for backing and blocking.
- 4. All material to be returned is to be neatly stacked according to type and size and placed on pallets or blocks ready to be picked up by the supplier.
- 5. All used lumber that will not be installed into the project is to be used cleaned by cutting off all broken ends and removing all nails and stacked.

3.6 INSTALLATION OF CONSTRUCTION PANELS

- A. Subflooring/Underlayment Combination: Glue and nail to framing; staples are not permitted.
- B. Wall Sheathing: Secure with long dimension perpendicular to wall studs, with ends over firm bearing and staggered, using screws.
 - 1. Place water-resistive barrier horizontally over wall sheathing, weather lapping edges and ends.
- C. Communications and Electrical Room Mounting Boards: Secure with screws to studs with edges over firm bearing; space fasteners at maximum 24 inches (610 mm) on center on all edges and into studs in field of board.
 - 1. At fire-rated walls, install board over wall board indicated as part of the fire-rated assembly.
 - 2. Where boards are indicated as full floor-to-ceiling height, install with long edge of board parallel to studs.
 - 3. Install adjacent boards without gaps.
 - 4. Size and Location: As indicated on drawings.

3.7 SITE APPLIED WOOD TREATMENT

- A. Apply preservative treatment compatible with factory applied treatment at site-sawn cuts, complying with manufacturer's instructions.
- B. Allow preservative to dry prior to erecting members.

3.8 TOLERANCES

- A. Framing Members: 1/4 inch (6 mm) from true position, maximum.

PART 1 - GENERAL**1.1 SUMMARY**

A. Section Includes:

1. Shop-fabricated wood roof trusses
2. Accessories for wood trusses: bridging, bracing and anchorage
3. Wood construction connectors for truss to truss connections

B. Related Sections:

1. Division 01: Administrative, procedural, and temporary work requirements.

1.2 SUMMARY

A. Section Includes:

1. Wood roof trusses.
2. Wood floor trusses.
3. Wood girder trusses.

1.3 DEFINITIONS

A. Metal-Plate-Connected Wood Trusses: Planar structural units consisting of metal-plate-connected members fabricated from dimension lumber and cut and assembled before delivery to Project site.

1.4 REFERENCES

A. ASTM International (ASTM):

1. A153 - Standard Specification for Zinc-Coating (Hot Dip) on Iron and Steel Hardware.
2. ASTM E 84 – Standard Test Method for Surface Burning Characteristics of Building Materials, 2008

B. Code and Design References:

1. ANSI/AF&PA – National Design Specification for Wood Construction, 2005 Edition
2. AF&PA – Manual for Engineered Wood Construction, 2005 Edition
3. ANSI/AF&PA – Special Design Provisions for Wind and Seismic, 2005 Edition
4. DOC PS 20-05 American Softwood Lumber Standard
5. ANSI TPI 1 – National Design Standard for Metal Plate Connected Wood Truss Construction

C. Grading Agencies:

1. Lumber Grading Agency: AITC – American Institute of Timber Construction
2. WWPA – Western Wood Products Association
3. SPIB – Southern Pine Inspection Bureau
4. NLGA – National Lumber Grades Authority
5. WCLIB – West Coast Lumber Inspection Bureau

D. Wood Construction Connectors:

1. Reference approved supplier's specifications.

1.5 SUBMITTALS

A. Submittals for Review:

1. Shop Drawings: Indicate sizes and spacing of trusses and associated components, web and chord sizes, plate sizes, fastener descriptions and spacings, loads and truss cambers and framed openings. Shop drawings to provide bearing, anchoring details, bridging and bearing details. Shop drawings to include a placement plan with corresponding detail sheets of each truss.
2. Structural Analysis data signed and sealed by a qualified Professional Engineer licensed in the state of project that is responsible for their preparation.

1.6 QUALITY ASSURANCE

A. Installer Qualifications: Use adequate numbers of skilled workmen who are thoroughly trained and experienced in the necessary crafts and who are completely familiar with the specified requirements and the methods needed for proper performance of the work in this section.

B. Fabricator Qualifications: Shop that participates in a recognized quality assurance program that involves inspection per ANSI TPI 1 requirements.

C. Listing and Labeling:

1. Grade Stamps: Provide lumber with each piece factory marked with grade stamp of inspection agency evidencing compliance with grade rule requirements and indentifying grading agency, grade, species, moisture content at time of surfacing, and mill.

1.5 DELIVERY, STORAGE AND HANDLING

A. General: Cover wood products to protect against moisture. Support stacked products to prevent deformation and to allow air circulation.

PART 2 – PRODUCTS

2.1 MANUFACTURERS

A. Acceptable Manufacturers – Wood Construction Connectors:

1. Simpson Strong-Tie
2. USP Structural Connectors

B. Substitutions: Under provisions of Division 01.

2.2 MATERIALS

A. Wood members: Comply with DOC PS 20 and requirements of specified grading agencies.

B. Steel Side Plate Connectors: Designed per TPI 1, hot dipped galvanized, die stamped for integral teeth and sized for joint loading.

C. Truss Bridging: Type, size and spacing as recommended by truss manufacturer's design professional.

D. Structural Framing Connectors, Joist Hangers: Galvanized steel, as specified on Structural Drawings. All alternative connectors must be submitted to Structural Engineer for approval prior to installation. Structural Framing Connectors in contact with pressure treated lumber to be coated with shop approved coating to prevent corrosion of hardware. All truss to truss connections are to be designed and detailed by truss manufacturer's design professional.

E. Treated Materials:

1. Preservative-Treated Materials: AWPA C2 lumber and AWPA C9 plywood, labeled by an inspection agency approved by ALSC's Board of Review. After treatment, kiln-dry lumber and plywood to 19 and 15 percent moisture content, respectively.

Treat indicated items on the drawings and the following:

- a. Wood members in connection with roofing, flashing, vapor barriers, and waterproofing.
- b. Concealed members in contact with masonry or concrete
- c. Wood framing members less than 18" above grade
- d. Wood floor plates installed over concrete slabs/foundation directly in contact with soil.

2.3 PERFORMANCE REQUIREMENTS

A. Delegated Design: Engage a qualified professional engineer, as defined in Section 01 4000 "Quality Requirements," to design metal-plate-connected wood trusses.

B. Structural Performance: Metal-plate-connected wood trusses shall be capable of withstanding design loads within limits and under conditions indicated. Comply with requirements in TPI 1 unless more stringent requirements are specified below.

1. Design Loads: As indicated.
2. Maximum Deflection under Design Loads:
 - a. Roof Trusses: Vertical deflection of As Indicated of span.
 - b. Floor Trusses: Vertical deflection of As Indicated of span.

C. Comply with applicable requirements and recommendations of TPI 1, TPI DSB, and SBCA BCSI.

D. Wood Structural Design Standard: Comply with applicable requirements in AF&PA's "National Design Specifications for Wood Construction" and its "Supplement."

2.4 DIMENSION LUMBER

A. Lumber: DOC PS 20 and applicable rules of any rules-writing agency certified by the American Lumber Standard Committee (ALSC) Board of Review. Provide lumber graded by an agency certified by the ALSC Board of Review to inspect and grade lumber under the rules indicated.

1. Factory mark each piece of lumber with grade stamp of grading agency.
2. For exposed lumber indicated to receive a stained or natural finish, omit grade stamp and provide certificates of grade compliance issued by grading agency.
3. Provide dressed lumber, S4S.
4. Provide dry lumber with 19 percent maximum moisture content at time of dressing.

B. Minimum Specific Gravity for Top Chords: 0.42.

C. Permanent Bracing: Provide wood bracing that complies with requirements for miscellaneous lumber in Section 06 1000 "Rough Carpentry."

2.5 FASTENERS

A. General: Provide fasteners of size and type indicated that comply with requirements specified in this article for material and manufacture.

1. Provide fasteners for use with metal framing anchors that comply with written recommendations of metal framing manufacturer.
2. Where trusses are exposed to weather, in ground contact, made from pressure-preservative treated wood, or in area of high relative humidity, provide fasteners with hot-dip zinc coating complying with ASTM A 153/A 153M.

B. Nails, Brads, and Staples: ASTM F 1667

2.6 METAL FRAMING ANCHORS AND ACCESSORIES

- A. Allowable design loads, as published by manufacturer, shall comply with or exceed those indicated. Manufacturer's published values shall be determined from empirical data or by rational engineering analysis and demonstrated by comprehensive testing performed by a qualified independent testing agency. Framing anchors shall be punched for fasteners adequate to withstand same loads as framing anchors.
- B. Galvanized-Steel Sheet: Hot-dip, zinc-coated steel sheet complying with ASTM A 653/A 653M, G60 coating designation.
 - 1. Use for interior locations unless otherwise indicated.
- C. Hot-Dip Heavy-Galvanized-Steel Sheet: ASTM A 653/A 653M; Structural Steel (SS), high-strength low-alloy steel Type A (HSLAS Type A), or high-strength low-alloy steel Type B (HSLAS Type B); G185 coating designation; and not less than 0.036 inch thick.
 - 1. Use for wood-preserved-treated lumber and where indicated.
- D. Stainless-Steel Sheet: ASTM A 666, Type 304 Type 316.

2.7 MISCELLANEOUS MATERIALS

- A. Galvanizing Repair Paint: SSPC-Paint 20, with dry film containing a minimum of 92 percent zinc dust by weight.

2.8 FABRICATION

- A. Cut truss members to accurate lengths, angles, and sizes to produce close-fitting joints.
- B. Fabricate metal connector plates to sizes, configurations, thicknesses, and anchorage details required to withstand design loads for types of joint designs indicated.
- C. Assemble truss members in design configuration indicated; use jigs or other means to ensure uniformity and accuracy of assembly, with joints closely fitted to comply with tolerances in TPI 1. Position members to produce design camber indicated.
 - 1. Fabricate wood trusses within manufacturing tolerances in TPI 1.
- D. Connect truss members by metal connector plates located and securely embedded simultaneously in both sides of wood members by air or hydraulic press.

2.08 SOURCE QUALITY CONTROL

- A. Special Inspections: Owner will engage a qualified special inspector to perform special inspections.
 - 1. Provide special inspector with access to fabricator's documentation of detailed fabrication and quality-control procedures that provide a basis for inspection control of the workmanship and the fabricator's ability to conform to approved construction documents and referenced standards.
 - 2. Provide special inspector with access to places where wood trusses are being fabricated to perform inspections.
- B. Correct deficiencies in Work that special inspections indicate do not comply with the Contract Documents.

PART 3 - EXECUTION

3.1 Shop Fabrication:

- A. Fabricate trusses to achieve structural requirements as specified on drawings. All loading and deflection criteria to be per IBC and ASCE 7-05 unless otherwise noted on the drawings by Structural Engineer.
- B. Truss supplier to make every effort to follow framing layout as shown on the Structural drawings as the loads have been distributed to the support walls/columns and foundation accordingly. If revised framing layouts are desired, truss supplier to submit proposed layout for review and approval by the Structural Engineer prior to foundation construction.
- C. Furnish bottom and top chord extensions as indicated on Structural or Architectural Drawings.
- D. Assemble trusses using jigs or other means to ensure uniformity and accuracy of assembly of joints closely fitted to comply with tolerances of TPI 1. Position members to produce design camber indicated.
- E. Frame special openings within the webs as detailed on the Drawings.
- F. Fabricate truss ends to accommodate the attachment to primary bearing supports as detailed on the Structural Drawings.
- G. Fabricate truss webbing to be coordinated with concentrated loads being applied to the truss.
- H. Provide truss installer HIB-91 publication outlining the proper handling, erection, and bracing of trusses.

3.2 Field Installation:

- A. Set trusses level, plumb and true to line. Place truss in location as shown on placement plan.
- B. Fasten and connect trusses in accordance with Structural drawings.
- C. Comply with member sizes, spacing, and configurations indicated, and fastener size and spacing as indicated on Structural drawings.
- D. Make provisions for the temporary construction loads and provide temporary bracing sufficient to maintain structure in true alignment and safe condition until completion of erection and installation of permanent bracing.
- E. Do not field cut or alter trusses without approval from both the Structural Engineer and the design professional of the truss supplier.
- F. Securely connect each truss ply required for forming built-up girder trusses as detailed by truss supplier.
- G. Install and fasten permanent bracing during truss erection and before construction loads are applied. Anchor ends of permanent bracing where terminating at walls or beams.
- H. Install wood trusses with installation tolerances per TPI 1.
- I. Remove damaged wood trusses that are damaged or do not meet requirements and replace with trusses that do meet requirements.

3.3 FIELD QUALITY CONTROL

A. Testing and Inspection Services:

- 1. Special Inspections: Owner will engage a qualified special inspector to perform special inspections to verify that temporary installation restraint/bracing and the permanent individual truss member restraint/bracing are installed in accordance with the approved truss submittal package.
- 2. Truss Installation: Inspect placement and attachment of trusses per Structural drawings.
- 3. Inspection Agency to submit testing/inspection reports to Architect and Engineer.

PART 1 GENERAL

1.1 SECTION INCLUDES

- A. Finish carpentry items, other than shop prefabricated casework.
- B. Wood handrails and Brackets
- C. Hardware and attachment accessories.
- D. Installation of finish hardware provided by Section 08 70 00.
- E. Interior Designer specifications provided by Section 09 00 00.

1.2 RELATED SECTIONS

- A. Section 06 10 00 –Rough Carpentry
- B. Section 06 62 00 – Cast Plastic Fabrications
- C. Section 08 11 00 - Steel Doors and Frames
- D. Section 08 30 00 – Traffic Doors
- E. Section 09 90 00 - Painting: Painting and finishing of finish carpentry items, (unless prefinished)

1.3 REFERENCES

- A. AWI - Quality Standards.
- B. FS MM-L-736 - Lumber; Hardwood.
- C. FS MMM-A-130 - Adhesive, Contact.
- D. PS 1 - Construction and Industrial Hardwood.
- E. PS 20 - American Softwood Lumber Standard.

1.4 SUBMITTALS

- A. Submit product data under provisions of Section 01 33 00

1.5 DELIVERY, STORAGE, AND HANDLING

- A. Deliver products to site under provisions of Section 01 60 00.
- B. Store and protect products under provisions of Section 01 60 00.
- C. Store materials in ventilated, interior locations under constant minimum temperatures of 60 degrees F and maximum relative humidity of 55 percent.

PART 2 PRODUCTS

2.1 LUMBER MATERIALS

- A. Softwood Lumber: PS 20; Custom grade in accordance with AWI; maximum moisture content of 6 percent.
- B. Hardwood Lumber: FS MM-L-736; Custom grade in accordance with AWI; maximum moisture content of 6 percent Red Oak species, with plain sliced grain, Grade 1, of quality capable of transparent finish.
- C. Interior trim materials provided and installed shall be SPECIFIED BY Interior Designer. Color and texture of embossed trim to be per Interior Designer. Sample required prior to placing order.
- D. Material Supplier is responsible to fully to familiarize himself with all aspects of material and installation design to ensure proposals are complete.
- E. Window sills to be specified by Interior Designer.

2.2 SHEET MATERIALS

- A. Softwood Plywood: PS 1; Standard Sheathing Grade, Group 1, Appearance Quality Fir species, with face veneer of rotary cut grain.
- B. Hardwood Plywood: ANSI/HPLA HP; Custom Grade in accordance with AWI; veneer core material Red Oak species, with face veneer of rotary cut.
- C. Particle Board: Shall be formaldehyde free complying with California 93120.

2.3 Quality Standard:

- A. Comply with AWI Section 300.1. Grade: Custom
- B. Handrail Model #900, 1 ½" x 1 ½" by Ferche Millwork, Inc. or equal
- C. Handrail Bracket at 32" o.c.:
 - 1. Ives model #059 or equal
 - 2. Oil Rubbed Bronze Finish or as specified by Interior Designer.

062000 - FINISH CARPENTRY

2.4 ACCESSORIES

- A. Nails: Size and type to suit application, plain finish.
- B. Bolts, Nuts, Washers, Blind Fasteners, Lags, and Screws: Size and type to suit application; galvanized finish.
- C. Lumber for Shimming, and Blocking Softwood lumber of Pine species.
- D. Closet Materials: per Interior Designer.
 - 1. Hang rods:
 - 2. Shelf and pole support:
- E. Shelving – Plastic coated wire shelving as selected by Interior Designer/Owner.
- F. Fiberglass reinforced paneling at all kitchen walls. Materials to include all misc. trim pieces for a complete job. Adhesive as recommended by manufacturer.

2.5 FABRICATION

- A. Fabricate to AWI Custom quality standards.
- B. Shop prepare and identify components for grain matching during site erection.

PART 3 EXECUTION

3.1 EXAMINATION

- A. Verify that surfaces are ready to receive work and field measurements are as shown on shop drawings.
- B. Verify mechanical, electrical, and building items affecting work of this Section are placed and ready to receive this work.
- C. Beginning of installation means acceptance of substrate.
- D. Upon delivery, inspect all finish materials, millwork for scratches, marks or other damage and reject all which cannot be satisfactorily repaired at the job site. Immediately notify the General Contractor or Owner of shortages or damaged materials needing replacement. Provide in writing an accurate count of materials for timely reorders.
- E. Cut opening in cabinet tops to receive sinks and built-in unit furnished by other sections. Work closely with respective sections to insure exact size openings are properly located.

3.2 PREPARATION

- A. Before installation, prime paint surfaces of items or assemblies to be in contact with cementitious materials.

3.3 INSTALLATION

- A. Install work in accordance with AWI Custom quality standard.
- B. Set and secure materials and components in place, plumb and level.
- C. Install components trim with nails.
- D. Finish Carpentry also to include:
 - 1. Installation of all bath and building accessories ie; towel bars, paper holders, grab-bars, shower rods, etc.
 - 2. Installation of all door hardware including: knobs, strikes, closers, door stops, thresholds, sweeps, panic hardware, electronic hardware, etc.
 - 3. All caulking of windows and sills, countertops and shower and bath bays.
 - 4. **Cabinet installation may or may not be included - confirm with General Contractor or Owner and note clearly on bid whether this is included or not.**

3.4 TOLERANCES

- A. Maximum Variation from True Position: 1/16 inch.
- B. Maximum Offset from True Alignment with Abutting Materials: 1/32 inch.

3.5 PREPARATION FOR SITE FINISHING

- A. Set exposed fasteners. Apply wood filler in exposed fastener indentations. Sand work smooth.
- B. Site Finishing: Refer to Section 09 90 00.

3.6 PROTECTION

- A. Protect finished installation under provisions of Section 01 50 00.

066200 - CAST PLASTIC FABRICATIONS

PART 1 GENERAL

1.1 SECTION INCLUDES

- A. Cast plastic fabrications.
 - 1. Cultured marble window sills.

1.2 REFERENCES

- A. ANSI Z124.3: American National Standard for plastic lavatories.
- B. CMI LS 2-76: Properties and performance standards for cultured marble lavatories
- C. HUD/FHA UM-73: Interim Standard for Plastic Lavatories with or without integral tops.
- D. UL

1.3 SUBMITTALS

- A. Submit shop samples, and product data in accordance with Section 01 33 00.
- B. Samples: Submit color samples to Architect for selection, (one color per product).

1.4 DELIVERY, STORAGE AND HANDLING

- A. Protect all material from damage due to moisture, weather and construction work.
- B. Do not deliver cultured marble until site conditions are adequate to receive the work of this Section.

1.5 COORDINATION

- A. Coordinate work.

PART 2 PRODUCTS

2.1 MANUFACTURERS

- A. Spartan Manufacturing
- B. Comparable products of other manufacturers.

2.2 MATERIALS

- A. Cultured Marble: 3/8" thick (sills), composed of not more than 75% granular marble and not less than 25% cure polyester resin with a clear sanitary gel coat.
- B. All material shall comply with JCMI LS-2-76, ANSI Z-124.3 and HUD/FHA UM-73.
- C. Size: As indicated or required.

PART 3 EXECUTION

3.1 EXAMINATION

- A. Verify that cabinets and windows are ready to receive the work. Field measure all locations.

3.2 INSTALLATION

- A. Install cultured marble sills in accordance with manufacturer's instructions.

3.3 CLEANING

- A. Clean work under provisions of 01 77 00.

PART 1 – GENERAL

1.1 DESCRIPTION

- A. Furnish and install a Pre-Fab protective column cover system in strict accordance with specification details and plan drawings.
- B. Section includes Free-Foam Cellular PVC Trim Boards for:
 - 1. Corner boards. 2. Soffits. 3. Fascia. 4. Battens. 5. Door pilasters. 6. Frieze boards. 7. Rake boards. 8. Pilasters.
 - 9. Water tables. 10. Architectural millwork. 11. Door trim. 12. Window trim. 13. Wainscoting. 14. Pergolas.
 - 15. Cupolas. 16. Porch Ceilings. 17. Hot tub surrounds. 18. Arbors. 19. Fencing. 20. Column wraps. 21. Skirt boards.

1.2 RELATED WORK

- A. Concrete footings to be poured by others including positioning of columns, as shown on plans.
- B. Light gauge metal framing.
- C. Veneer gypsum plaster.
- D. Finishing glass fiber reinforced gypsum.
- E. Finish Carpentry
- F. Painting and Coating
- G. Miscellaneous metals.

1.3 SUBMITTALS

- A. Furnish shop drawings bearing the seal of a state registered structural engineer to indicate proper construction in compliance with all local codes including, but not limited to, wind ratings, load bearing, footings required, spacing of posts in accordance with fire codes for entrance and egress, and drainage of precipitation. Shop drawings must completely detail prefabricated glass fiber reinforced gypsum Members, including locations, sizes and shapes of members, proposed jointing arrangements, details of anchorages and supports, suspensions systems, outlet boxes, and other items which are affected by prefabricated gypsum members.
- B. Submit signed Certification by a state registered structural engineer that design complies with latest Standard building Code applicable to location and applicable ANSI/ASCE requirements. Manufacturer's Certificates: Certify products meet or exceed specified requirements.
- C. Submit detailed product data on all components including part numbers and characteristics. Manufacturer's data sheets on each product to be used, including: 1. Preparation instructions and recommendations. 2. Storage and handling requirements and recommendations. 3. Installation methods.
- D. LEED Submittals: Provide documentation of how the requirements of Credit will be met: 1. List of proposed materials with recycled content. Indicate post-consumer recycled content and pre-consumer recycled content for each product having recycled content. 2. Product data and certification letter indicating percentages by weight of postconsumer and pre-consumer recycled content for products having recycled content. 3. List of proposed materials demonstrating that each material was extracted, harvested or recovered, as well as manufactured within 500 miles of the project site.
- E. Verification Samples: For each product specified, two samples, minimum size 6 inches (150 mm) long, representing actual product, color, and finish, per Section 013300.

1.4 REFERENCES

- A. ASTM D 792 - Density and Specific Gravity of Plastics by Displacement.
- B. ASTM D 570 - Water Absorption of Plastics.
- C. ASTM D 638 - Tensile Properties of Plastics.
- D. ASTM D 790 - Flexural Properties of Unreinforced and Reinforced Plastics and Electrical Insulating Materials.
- E. ASTM D 1761 - Mechanical Fasteners in Wood.
- F. ASTM D 5420 - Standard Test Method for Impact Resistance of Flat, Rigid Plastic Specimen by means of a Striker Impacted by a Falling Weight.
- G. ASTM D 256 - Determining the Pendulum Impact Resistance of Plastics.
- H. ASTM D 696 - Coefficient of Linear Thermal Expansion of Plastics Between minus 30 degrees C and plus 30 degrees C with a Vitreous Silica Dilatometer.
- I. ASTM D 635 - Rate of Burning and/or Extent and Time of Burning of Plastics in a Horizontal Position.
- J. ASTM E 84 - Surface Burning Characteristics of Building Materials.
- K. ASTM D 648 - Deflection Temperature of Plastics Under Flexural Load in the Edgewise Position.
- L. ASTM D 3679 - Standard Specification for Rigid Poly Vinyl Chloride (PVC) Siding.
- M. ASTM D 2240 - Rubber Property - Durometer Hardness
- N. ASTM D 3345 - Standard Test Method for Laboratory Evaluation of Wood and Other Cellulosic Materials for Resistance to Termites.

1.5 STANDARDS of PERFORMANCE, DESIGN, and QUALITY

Manufacturer Qualifications: Manufacturer with a minimum of 5 years producing PVC trim products.

- A. Installer Qualifications: Installer with a minimum of 3 years experience with the installation of PVC trim products.
- B. Mock-Up: Provide a mock-up for evaluation of surface preparation techniques and application workmanship.
 - 1. Finish areas designated on plans.
 - 2. Do not proceed with remaining work until workmanship, color, and sheen are approved by Architect.
 - 3. Refinish mock-up area as required to produce acceptable work.
 - 4. Accepted mock-ups shall be comparison standard for remaining Work

1.6 DELIVERY, STORAGE, AND HANDLING

- A. Store products on a flat and level surface on a full shipping pallet. Handle materials to prevent damage to product edges and corners.
- B. Store materials under a protective covering to prevent jobsite dirt and residue from collecting on the boards.

1.7 SEQUENCING

- A. Ensure that products of this section are supplied to affected trades in time to prevent interruption of construction progress.

1.8 PROJECT CONDITIONS

- A. Maintain environmental conditions (temperature, humidity, and ventilation) within limits recommended by manufacturer for optimum results. Do not install products under environmental conditions outside manufacturer's absolute limits.

1.9 WARRANTY

- A. Provide manufacturer's transferable limited lifetime warranty against defects in manufacturing that causes the products to rot, corrode, delaminate, or excessively swell from moisture.

PART 2 PRODUCTS

2.1 MANUFACTURERS

A. Acceptable Manufacturers:

- 1. VERSATEX
400 Steel St. Aliquippa, PA 15001; Tel: 724-857-1111; Fax: 724-857-1171;
Email request info (sales@versatex.com); Web:www.versatex.com
- 2. TURNCRAFT
PO Box 2429 White City OR 97503 1-800-423-3311
Email request: info@turncraft.com Web: www.turncraft.com
- 3. Approve Equal ; Requests for substitutions will be considered in accordance with provisions of Section 01 60 00 - Product Requirements.

2.2 MATERIALS

A. PVC: Free Foam Cellular PVC material with a small-cell microstructure and density of .55 grams/cm3.

- 1. Performance and physical characteristic requirements:
 - a. Physical:
 - 1. Density: 0.55 g/cm3when tested in accordance with ASTM D 792.
 - 2. Water Absorption: Less then 0.50 percent when tested in accordance with ASTM D 570
 - b. Mechanical:
 - 1. Tensile Strength: 3582 psi when tested in accordance with ASTM D 638.
 - 2. Tensile Modulus: 107,000 psi when tested in accordance with ASTM D 638.
 - 3. Flexural Strength: 5179 psi when tested in accordance with ASTM D 790.
 - 4. Flexural Modulus: 215,600 psi when tested in accordance with ASTM D 790.
 - 5. Modulus of Elasticity: 209,500 psi when tested in accordance with ASTM D 638.
 - 6. Elongation: 9.0 percent when tested in accordance with ASTM D 638.
 - 7. Nail Hold: 398 lbf/in of penetration when tested in accordance with ASTM D 1761.
 - 8. Compressive Strength: 6,553 psi (thickness dependent)
 - 9. Compressive modulus: 2,305 lbf/in (thickness dependent)
 - 10. Screw Hold: 240 lbf/in of penetration when tested in accordance with ASTM D 1761.
 - 11. Staple Hold: 69 lbf/in of penetration when tested in accordance with ASTM D 1761.
 - 12. Gardner Impact: 34 In-lbs when tested in accordance with ASTM D 5420.
 - 13. Notched Izod Impact: 0.270 Ft-lbs/inch when tested in accordance with ASTM D 256.
 - 14. Termite Resistance: Rating of 10 as tested in accordance with ASTM D 3345.
 - 15. Hardness: 60+ when tested in accordance with ASTM D 2240.
 - 16. Parking Garage Ceiling Soffit System: 225 psf when tested in accordance with UL 580.

- c. Thermal:
 - 1. Coefficient of Linear Expansion: 3.25 x 10⁻⁵ in/in/degrees F when tested in accordance with ASTM D 696.
 - 2. Burning Rate: Failed to Ignite when tested in accordance with ASTM D 635.
 - 3. Flame Spread Index: 20 when tested in accordance with ASTM E 84.
 - 4. Heat Deflection Temp (264 psi): 146 degrees F when tested in accordance with ASTM D 648.
 - 5. Heat Deflection Temp (66 psi): 153 degrees F when tested in accordance with ASTM D 648.
 - 6. Oil Canning (@ 140 degrees F: Passed when tested in accordance with ASTM D 648.
- 2. Manufacturing Tolerances:
 - a. Variation in component length: Minus 0.00 / plus 1.00.
 - b. Variation in component width: plus or minus 1/32 inch.
 - c. Variation in component thickness: plus or minus 1/32 inch.
 - d. Variation in component edge cut: plus or minus 2 degrees.
 - e. Variation in Density plus or minus 0.02 grams per cubic centimeter.
- 3. Workmanship, Finish, and Appearance:
 - a. Free Foam Cellular PVC that is homogeneous and free of voids, holes, cracks, foreign inclusions and other defects. Edges must be square and top and bottom surfaces shall be flat with no convex or concave deviation.
 - b. Uniform surface free from cupping, warping, and twisting.

2.3 SIMULATED WOOD TRIM

- A. PVC Trimboard: Versatex Trimboard with Sealed Edge, designed with a natural appearance to compliment fiber cement and natural cedar.
 - 1. Size:
 - a. Nominal Width: verify with GC.
 - b. Nominal Thickness: verify with GC.
 - c. Length: verify with GC.
 - 2. Finish: Verify with GC.
- B. Sheet Board: Versatex S4S (Smooth) Sheet. For use as sheet materials or to create columns and gingerbread millwork.
- C. PVC Cornerboard: Versatex Corners: Folded, 90 degree, one-piece assembly produced with a smooth or timber ridge appearance to compliment fiber cement and natural cedar.
- D. PVC Bead Board: Versatex Beadboard: Tongue-and-Groove Beaded Sheets.
- E. Mouldings: Versatex Mouldings designed to compliment exterior trim.
 - 1. Crowns: Verify with GC.
 - 2. Casings: Verify with GC.
 - 3. Cove: Verify with GC.
 - 4. Sill: Verify with GC.
 - 5. Specialty: Verify with GC.
 - 6. Length: Verify with GC.
 - 7. Finish: Verify with GC.

2.4 SIMULATED WOOD TRIM

- A. PVC Columnwrap: Versawrap one-piece column wraps.
 - 1. Size:
 - a. Nominal Width: verify with GC.
 - b. Nominal Thickness: verify with GC.
 - c. Length: verify with GC.
 - 2. Finish: Verify with GC.
- B. PVC Columnwrap: Versawrap Accessories.
 - 1. Accent Wrap Size: Verify with G.C.
 - 2. Post Caps Nominal Sizes: Verify with GC.
 - 3. Trim Kits
 - a. Base Cap
 - b. Bed Mould
 - c. Bed Mould XL
 - d. 4 inch Crown Moulding
 - e. 4 inch Crown Moulding XL
 - 4. Finish:
 - a. Smooth finish.

2.5 ACCESSORIES

A. Fasteners:

1. Use 12 gauge stainless steel fasteners designed for wood trim and siding. Fastener should have sufficient flexural and tensile strength to resist bending.
2. Use fasteners with thin shanks, blunt points, and full round heads that are long enough to penetrate the substrate a minimum of 1-1/4 inches.
3. Do not use staples, small brads and wire nails. Avoid using fine threaded wood screws and ring-shank fasteners.
4. Use standard nail guns with a pressure setting between 70 psi and 100 psi. The recommended pressure depends on the type of gun, type of nail, ambient temperature, and the substrate. Care should be taken not to overdrive the nail into the material.
5. Pre-drilling is not typically required unless large fasteners are used or the product is installed during temperatures below 40 degrees F.
6. Use two fasteners for every framing member for trimboard applications. Sheet and trimboards 8 inches and wider require additional fasteners.
7. Install fasteners no more than 2 inches from the end of each board.
8. Avoid fastening simulated wood trim over hollow or uneven areas. Fasten onto flat, solid substrates.
9. 3/8 inch and 1/2 inch thick Sheet and Beadboard is not designed to be ripped and used for trim applications. These products must be glued and mechanically fastened to the substrate.

B. Adhesives: Finishing System.

1. All bonded surfaces must be smooth, clean, and in complete contact with each other for best results.
2. Adhere simulated wood trim to itself with PVC cement or cellular PVC adhesives to prevent joint separation. Acceptable adhesives are PVC Trim Welder, IPS Weld-On 705 (white), and Zevo PVC Trim adhesive.
3. PVC cements cure quickly (3-5 minutes or less), and have a limited working time.
4. Scarf cut joints are recommended where applicable.
5. Bonded joints should be secured with fasteners and fastened with two rows on each side of the joint.
6. When bonding simulated wood trim to other substrates, consult the adhesive manufacturer to determine suitability.

C. Nail Hole Filler: Cortex plug system by Fasten Master.

D. Sealants:

1. Use urethane, polyurethane, polymer blends or acrylic based sealants that do not contain silicone as specified in Section 07 91 16 - Joint Gaskets.

PART 3 EXECUTION

3.1 EXAMINATION

- A. Do not begin installation until substrates have been properly prepared.
- B. If substrate preparation is the responsibility of another installer, notify Architect of unsatisfactory preparation before proceeding.

3.2 PREPARATION

- A. Clean surfaces thoroughly prior to installation.
- B. Prepare surfaces using the methods recommended by the manufacturer for achieving the best result for the substrate under the project conditions.

3.3 INSTALLATION

- A. Install in accordance with manufacturer's instructions.
- B. Cutting: 1. Simulated wood trim can be cut using standard woodworking saws. Conventional carbide-tipped blades designed for cutting wood are preferred. Avoid using fine-tooth metal-cutting blades. 2. Rough-cut edges are typically caused by excessive friction, poor board support, or worn or improper tooling.
- C. Drilling: 1. Simulated wood trim can be drilled using standard woodworking drill bits. Do not use drill bits made for rigid PVC. 2. Avoid frictional heat build-up. 3. Remove shavings periodically from a drill hole as necessary.
- D. Milling and Moulding: 1. Simulated wood trim can be milled or moulded using standard milling or moulding machines found in millwork shops. 2. Rake angle 20 to 30 degrees. 25 degrees is recommended. 3. Cutting speed to be optimized with the number of knives and feed rate.

- E. Routing: 1. Simulated wood trim can be routed with virtually any piece of equipment used to rout wood. 2. Carbide tipped router bits are recommended. 3. Machinery that allows for multiple cutting speeds will allow you to optimize the process obtaining a smoother finished part.
- F. Edge Finishing: 1. Traditional sanding, grinding or filing tools used for woodworking are preferred.
- G. Nail Location: 1. For trimboard applications use two fasteners per framing member. 2. Use additional fasteners (3/4 inch preferred) for trimboard 8 inches and wider. 3. Install fasteners a maximum of 2 inches from the end of each board.
- H. Expansion and Contraction: 1. Simulated wood trim expands and contracts with changes in temperature. Properly fastening along the entire length is required to minimize expansion and contraction. 2. Allow 3/16 inch space per 18-foot run of trim for expansion and contraction. 3. Bond joints between pieces of simulated wood trim to eliminate separation. 4. Allow expansion and contraction space at the ends of long runs.
- I. Cleaning: 1. Clean simulated wood trim with mild detergent and water. 2. Products with pumice, such as Soft Scrub, may be applied with a nylon brush. 3. For more stubborn stains use a mild household cleaner and degreaser like Clorox Cleanup, Clorox Outdoors, Denatured Alcohol, Bleach, Mr. Clean Magic Eraser or Corte Clean with nylon brush.
- J. Painting:
1. Be sure surface to be painted is clean, dry, and free of dirt, loose or peeling paint, mildew, chalk, grease and any other surface contaminants before paint application.
 2. Finish nail holes with nail hole filler or a UV resistant acrylic caulk.
 3. Paint as specified in Section 09 90 00 - Painting and Coating.
 - a. Use 100 percent acrylic latex or 100 percent acrylic latex with urethane additive paint with a light reflective value (LRV) equal to or greater than 55 units.
 - b. Follow the paint manufacturer's application recommendations.

3.4 PROTECTION and CLEANUP:

- A. Protect installed products until completion of project.
- B. Touch-up, repair or replace damaged products before Substantial Completion
- C. Perform cleaning procedures as recommended by manufacturer.

3.5 GUARANTEE:

- A. One year from substantial completion

PART 1: GENERAL

1.1 SECTION INCLUDES

A. Sheet membrane waterproofing.

1.2 RELATED REQUIREMENTS

A. Section 03 3000 - Cast-in-Place Concrete: Concrete substrate.

B. Section 07 2100 - Thermal Insulation: Insulation used for protective cover.

1.3 REFERENCE STANDARDS

A. ASTM D412 - Standard Test Methods for Vulcanized Rubber and Thermoplastic Elastomers--Tension; 2006a (Reapproved 2015a).

B. ASTM D570 - Standard Test Method for Water Absorption of Plastics; 1998 (Reapproved 2010).

C. ASTM D882 - Standard Test Method for Tensile Properties of Thin Plastic Sheeting; 2012.

D. ASTM D903 - Standard Test Method for Peel or Stripping Strength of Adhesive Bonds; 1998 (Reapproved 2010).

E. ASTM D1876 - Standard Test Method for Peel Resistance of Adhesives (T-Peel Test); 2008 (Reapproved 2015).

F. ASTM D1970/D1970M - Standard Specification for Self-Adhering Polymer Modified Bituminous Sheet Materials Used as Steep Roofing Underlayment for Ice Dam Protection; 2015a.

G. ASTM D5295/D5295M - Standard Guide for Preparation of Concrete Surfaces for Adhered (Bonded) Membrane Waterproofing Systems; 2014.

H. ASTM D5385/D5385M - Standard Test Method for Hydrostatic Pressure Resistance of Waterproofing Membranes; 1993 (Reapproved 2014).

I. ASTM E96/E96M - Standard Test Methods for Water Vapor Transmission of Materials; 2014.

J. ASTM E154/E154M - Standard Test Methods for Water Vapor Retarders Used in Contact with Earth Under Concrete Slabs, on Walls, or as Ground Cover; 2008a (Reapproved 2013).

1.4 SUBMITTALS

A. See Section 01 3000 - Administrative Requirements, for submittal procedures.

B. Product Data: Provide data for membrane.

C. Shop Drawings: Indicate special joint or termination conditions and conditions of interface with other materials.

D. Manufacturer's Installation Instructions: Indicate special procedures.

1.5 QUALITY ASSURANCE

A. Membrane Manufacturer Qualifications: Company specializing in waterproofing sheet membranes with three years' experience.

PART 2: PRODUCTS

2.1 MANUFACTURERS

A. Manufacturer specification by Polyguard; VERIFY WITH G.C.

B. Approved equal.

2.2 MEMBRANE MATERIALS

A. Self-Adhered Modified Bituminous Membrane <WTR PRF-2>: Self-adhesive, cold-applied composite sheet consisting of rubberized asphalt and cross-laminated, high density polyethylene film.

1. Thickness: 60 mil (0.060 inch) (1.5 mm).

2. Tensile Strength:

a. Film: 5000 pounds per square inch (34.57 MPa), minimum, measured according to ASTM D882 and at grip-separation rate of 2 inches (50 mm) per minute.

b. Membrane: 325 pounds per square inch (2.24 MPa), minimum, measured according to ASTM D412 Method A, using die C and at spindle-separation rate of 2 inches (50 mm) per minute.

3. Elongation at Break: 300 percent, minimum, measured according to ASTM D412.

4. Water Vapor Permeance: 0.05 perm (2.9 ng/(Pa s sq m)), maximum, measured in accordance with ASTM E96/E96M.

5. Low Temperature Flexibility: Unaffected when tested according to ASTM D1970/D1970M at minus 20 degrees F (minus 11 C), 180 degree bend on 1 inch (25 mm) mandrel.

6. Low Temperature Installation: Installation air and surface temperature between 25 and 60 degrees F or lower.

7. Peel Strength: 9 pounds per inch (1576 N/m), minimum, when tested according to ASTM D903.

8. Lap Adhesion Strength: 5 pounds per inch (875.6 N/m), minimum, when tested according to ASTM D1876.

9. Puncture Resistance: 50 pounds (22.67 kg), minimum, measured in accordance with ASTM E154/E154M.

10. Water Absorption: 0.1 percent increase in weight, maximum, measured in accordance with ASTM D570, 24 hour immersion.

11. Hydrostatic Resistance: Resists the weight of 200 feet (61 m) when tested according to ASTM D5385/D5385M.
12. Adhesives, Sealants, Tapes, and Accessories: As recommended by membrane manufacturer.
13. Basis of Design Products:
 - a. Carlisle Coatings & Waterproofing Incorporated; MiraDRI 860/861: www.carlisleccw.com/sle.
 - b. GCP Applied Technologies; Bituthene 3000/Low Temperature Membrane: www.gcpat.com/sle.
 - c. W.R. Meadows, Inc; MEL-ROL Low Temp: www.wrmeadows.com/sle.
 - d. Substitutions: See Section 01 6000 - Product Requirements.

B. Self-Adhered HDPE Sheet Membrane with Weather-Resistant Coating <WTR PRF-7>: Recommended by manufacturer for placement below concrete slabs and on outside face of below grade walls before placement of concrete.

1. Sheet Thickness: 46 mil (0.046 inch) (1.2 mm), minimum.
2. Low Temperature Flexibility: Unaffected when tested according to ASTM D1970/D1970M at minus 20 degrees F (minus 11 C), 180 degree bend on 1 inch (25 mm) mandrel.
3. Low Temperature Installation: Installation air and surface temperature between 25 and 60 degrees F or lower.
4. Hydrostatic Resistance: Resists the weight of 231 feet (70 m) when tested according to ASTM D5385/D5385M.
5. Elongation at Break: 500 percent, minimum, measured according to ASTM D412.
6. Tensile Strength, Film: 3,500 pounds per square inch (24 MPa), minimum, measured according to ASTM D412.
7. Lap Peel Adhesion: 8 pounds per inch (1408 N/m), minimum, when tested according to ASTM D1876.
8. Water Vapor Permeance: 0.01 perm (0.6 ng/(Pa s sq m)), maximum, measured in accordance with ASTM E96/E96M.
9. Bond to Concrete: 5 pounds per inch (875 N/m), minimum, per ASTM D903.
10. Lateral Water Migration Resistance: Resists the weight of 231 feet (70 m) when tested according to ASTM D5385/D5385M.
11. Adhesives, Sealants, Tapes, and Accessories: As recommended by membrane manufacturer.
12. Manufacturers:
 - a. GCP Applied Technologies; Preprufe 300R Plus: www.gcpat.com/sle.
 - b. Carlisle Coatings & Waterproofing Incorporated; MiraPLY-H: www.carlisle-ccw.com.
 - c. W.R. Meadows, Inc; PRECON Low Temp: www.wrmeadows.com.
 - d. Substitutions: See Section 01 6000 - Product Requirements.

2.2 ACCESSORIES

A. Sealant for Cracks and Joints In Substrates: Resilient elastomeric joint sealant compatible with substrates and waterproofing materials.

B. Protection Board: Rigid insulation specified in Section 07 2100.

C. Drainage Panel <DRAIN BRD-1>: Drainage layer with geotextile filter fabric on earth side.

1. Also provide at locations where <INSUL-1> is not installed over <WTR PRF-2>.
2. Composition: Dimpled polystyrene core; polypropylene filter fabric.
 - a. Products:
 - 1) Grace Construction Products; Hydroduct 200: www.na.graceconstruction.com.
 - 2) Carlisle Coatings & Waterproofing Incorporated; MiraDRAIN 2000: www.carlisle-ccw.com.
 - 3) W.R. Meadows, Inc; Mel-Drain: www.wrmeadows.com.
 - 4) Substitutions: See Section 01 6000 - Product Requirements.

D. Flexible Flashings: Type recommended by membrane manufacturer.

PART 3 EXECUTION

3.1 EXAMINATION

- A. Verify existing conditions before starting work.
- B. Verify substrate surfaces are durable; free of matter detrimental to adhesion or application of waterproofing system.
- C. Verify that items that penetrate surfaces to receive waterproofing are securely installed.
- D. As shown on Drawings; Installation per specifications as follows and according to G.C.

3.2 PREPARATION

- A. Protect adjacent surfaces not designated to receive waterproofing.
- B. Clean and prepare surfaces to receive waterproofing in accordance with manufacturer's instructions. Vacuum substrate clean.
- C. Do not apply waterproofing to surfaces unacceptable to membrane manufacturer.
- D. Fill non-moving joints and cracks with a filler compatible with waterproofing materials.
- E. Seal moving cracks with sealant, not rigid filler, using procedures recommended by sealant and waterproofing manufacturers.
- F. Surfaces for Adhesive Bonding: Apply surface conditioner at a rate recommended by manufacturer. Protect conditioner from rain or frost until dry.

G. Concrete Surfaces for Adhesive Bonding: Prepare concrete substrate according to ASTM D5295/D5295M.

1. Remove substances that inhibit adhesion including form release agents, curing compounds admixtures, laitance, moisture, dust, dirt, grease and oil.
2. Repair surface defects including honeycombs, fins, tie holes, bug holes, sharp offsets, rutted cracks, ragged corners, deviations in surface plane, spalling and delaminations, as described in the reference standard.
3. Remove and replace areas of defective concrete as specified in Section 03 3000.
4. Prepare concrete for adhesive bonded waterproofing using mechanical or chemical methods described in the referenced standard.
5. Test concrete surfaces as described in the referenced standards. Verify surfaces are ready to receive adhesive bonded waterproofing membrane system.

3.3 INSTALLATION - MEMBRANE

- A. Install membrane waterproofing in accordance with manufacturer's instructions.
- B. Roll out membrane. Minimize wrinkles and bubbles.
- C. Self-Adhering Membrane: Remove release paper layer. Roll out on substrate with a mechanical roller to encourage full contact bond.
- D. Overlap edges and ends and seal by method recommended by manufacturer, minimum 3 inches (75 mm). Seal permanently waterproof.
- E. Reinforce membrane with multiple thickness of membrane material over joints, whether joints are static or dynamic.
- F. Weather lap joints on sloped substrate in direction of drainage. Seal joints and seams.
- G. Install flexible flashings. Seal items penetrating through membrane with flexible flashings. Seal watertight to membrane.
- H. Seal membrane and flashings to adjoining surfaces. Install termination bar at all edges. Install counterflashing over all exposed edges.

3.4 INSTALLATION - DRAINAGE PANEL

- A. Place drainage panel directly against membrane, butt joints, place to encourage drainage downward. Scribe and cut boards around projections, penetrations, and interruptions.
- B. Adhere drainage panel to substrate with compatible adhesive.

3.5 PROTECTION

- A. Do not permit traffic over unprotected or uncovered membrane.

PART 2: PRODUCTS

- A. Concrete under slab vapor barrier - 6 mil. thickness membrane.

Nervastral P.E.T. - Rubber and Plastics Compound Co.
Visqueen - Visking Company
Polyfilm - Dow Chemical Company
Moistop 2 - St. Regis Paper Company

- B. Insulate wall and ceiling vapor barrier - 4 mil. thickness membrane.

Nervastral P.E.T. - Rubber and Plastics Compound Co.
Visqueen - Visking Company
Polyfilm - Dow Chemical Company
Durathene - The Koppers Company

PART 3: EXECUTION

- A. Under slabs - install continuously under all slabs-on-grade. Lap 6" and seal joints.

- B. Walls and Ceilings - Place over exterior stud walls and bottom of floor trusses, lap 6". Staple to studs and trusses. Place prior to installing drywall.

- C. Place in continuous uninterrupted application. Do not splice small pieces.

- D. Vapor barrier must be installed in such a manner that will not interfere with the installation of the drywall materials. Do not bunch material so as to prevent direct contact with framing members.

- E. **DO NOT install vapor barrier to walls if the floor area along the walls has not been cleaned of all wood chips and debris.**

- F. Confirm with General Contractor or Owner whether windows are to be cut out or left covered (weather considerations).



All caulking must have low-VOC contents per EGCC 6.2

PART 1: GENERAL

- A. Exterior material shall be as manufactured by Sonneborn Building Products, Inc. (Hydrocide Mastic); Toch Brother, Inc. (RIW Marine Mastic); The Phillip Carrey Manufacturing Company (Carrey Mastic); or approved equal.
- B. Interior caulking shall be 100% silicone material treated to prevent formation of mildew.
- C. Foam rope material shall be used prior to caulking all expansion joints.

PART 2: MATERIALS

- A. Remove all projections from the face of surfaces to be caulked, brush down all dirt and loose particles before applying materials.
- B. Fill holes and voids prior to applying caulking material with foam rope caulk material. Backing material to be applied to allow for caulking material to be at a thickness of at least 1/8" and remain embedded just below the surface of the surrounding material surface.
- C. Apply damp-proofing material in one coat, to a thickness of at least 1/8". Coating shall be continuous without breaks or pinholes. Carry mastic over tops of footings, into all corners, reveals and grooves.
- D. No work is to be done during wet weather or when the temperature is below 45° F. unless the walls are enclosed, heated and dried.

PART 3: EXECUTION

- A. Interior Caulking shall be installed at the following locations:
 - 1. Around entire perimeter of all windows
 - 2. Around perimeter of all built-in air conditioning sleeves (prior to installing trim work)
 - 3. At all countertop and wall connection.
 - 4. Around entire perimeter of bath and shower bays.
- B. Prior to placing caulking material all adjoining surfaces are to be completely clean and free of loose particles.
- C. Caulking of interior surfaces is to be installed after the area has reached the point of substantial completion to avoid excessive dust and dirt accumulation on newly caulked surfaces.
- D. Caulking is to be places in a smooth, continuous, coating at least 1/8" thick. Place material into joint under pressure to force into voids. Finger smooth all caulk beads.
- E. Immediately clean excess caulking from surrounding materials using solvent to remove all residue.

072120 Board Insulation

1. PART 1 GENERAL

1.1 SECTION INCLUDES

- A. Board insulation at perimeter foundation wall, cavity wall, or where indicated or required.

1.2 RELATED SECTIONS

- A. Section 03 10 00 - Concrete
- B. Section 04 20 00 - Unit Masonry

1.3 REFERENCES

- A. ANSI/ASTM D2842 - Water Absorption of Rigid Cellular Plastics.
- B. ASTM C578 - Preformed Cellular Polystyrene Thermal Insulation.
- C. ASTM E96 - Test Methods for Water Vapor Transmission of Materials.

1.4 ENVIRONMENTAL REQUIREMENTS

- A. Do not install insulation adhesives when temperature or weather conditions are detrimental to successful installation.

1.5 COORDINATION

- A. Coordinate work under provisions of Section 01 31 13.
- B. Provide certification that all insulation has been installed in accordance with specifications for designated R-values, minimum thickness and density.

2. PART 2 PRODUCTS

2.1 INSULATION MATERIALS

- A. Polystyrene Insulation: ASTM C578 Type IV extruded cellular type, conforming to the following:
 - Thermal Resistance R of 5.0 per inch
 - Thickness 2" or as indicated
 - Water Absorption In accordance with ANSI/ASTM D2842 0.3 percent by volume maximum
 - Edges Square

2.2 MATERIALS

- A. Adhesive: Type recommended by insulation manufacturer for application.

3. PART 3 EXECUTION

3.1 EXAMINATION

A. Verify site conditions under provisions of Section 01 31 13.

- B. Verify that substrate, adjacent materials, and insulation boards are dry and ready to receive insulation and adhesive.
- C. Verify substrate surface is flat, free of irregularities materials or substances that may impede adhesive bond.

3.2 INSTALLATION - FOUNDATION PERIMETER

- A. Adhere boards to foundation wall perimeter, horizontally. Place boards in a method to maximize contact bedding. Stagger side and end joints. Butt edges and ends tight to adjacent board and to protrusions.
- B. Extend boards over control joints, un-bonded to foundation 2 inches on one side of joint.

3.3 PROTECTION OF FINISHED WORK

- A. Protect finished Work under provisions of Section 01 60 00.
- B. Do not permit Work to be damaged prior to covering insulation.

072120 Sprayed Insulation

1. PART 1 GENERAL

1.1 RELATED DOCUMENTS

- A. Drawings and general provisions of the Contract, including General and Supplementary Conditions and Division 01 Specification Sections, apply to this Section.

1.2 SUMMARY

- A. Section Includes:
 - 1. Spray-applied, polyurethane foam insulation in exterior stud wall construction. Install in areas indicated on the drawings.
- B. Related Sections:
 - 1. Division 06 Section "Miscellaneous Rough Carpentry" for wood blocking, curbs, cants, and nailers.
 - 2. Division 07 Section "Sheet Metal Flashing and Trim" for wall penetration flashings, and counter flashings.
 - 3. Division 07 Section "Joint Sealants" for joint sealants, joint fillers, and joint preparation.

1.3 PERFORMANCE REQUIREMENTS

A. Material Compatibility: Provide polyurethane foam and miscellaneous materials that are compatible with one another and able to bond to substrate under conditions of service and application required, as demonstrated by coated foamed manufacturer based on testing and field experience.

1.4 SUBMITTALS

A. Product Data: For each type of product indicated. Include manufacturer's written instructions for evaluating, preparing, and treating substrate; technical data; and tested physical and performance properties.

B. Qualification Data: For SPFA-qualified Installer.

C. Product Test Reports: Based on evaluation of comprehensive tests performed by a qualified testing agency.

1.5 QUALITY ASSURANCE

A. Source Limitations: Obtain polyurethane foam materials from single source or producer and coating products from single manufacturer.

B. Fire-Test-Response Characteristics: Provide systems with the fire-test-response characteristics indicated, as determined by testing identical systems per test method indicated below by UL or another testing and inspecting agency acceptable to authorities having jurisdiction. Identify materials with appropriate markings of applicable testing and inspecting agency.

1. Surface-Burning Characteristics: Maximum flam-spread and smoke-developed indexes of 75 and 450, respectively; ASTM E 84.

C. Pre-installation Conference: Conduct conference at Project site.

1. Review methods and procedures including, but not limited to, the following:

- a. Structural load limitations.
 - b. Construction schedule. Verify availability of materials, Installer's personnel, equipment, and facilities needed to make progress and avoid delays.
 - c. Certifying procedures.
- d. Surface preparation specified in other Sections.
 - e. Substrate condition and pretreatment.
 - f. Minimum curing period.
 - g. Forecasted weather conditions.
 - h. Special details and sheet flashings.
 - i. Installation procedures.
 - j. Testing and inspection procedures.
 - k. Protection and repairs.

1.6 DELIVERY, STORAGE, AND HANDLING

A. Deliver materials to Project site in original containers with seals unbroken, labeled with manufacturer's name, product brand name and type, date of manufacture, shelf life, and directions for storing and mixing with other components.

B. Store materials in their original undamaged containers in a clean, dry, protected location and within the temperature range required by manufacturer. Protect stored materials from direct sunlight.

C. Remove and replace material that cannot be applied within its stated shelf life.

1.7 PRODUCT CONDITIONS

A. Environmental Limitations: Do not deliver or install sprayed installation until openings, curbs, and parapets, if any, are complete and vents, and other penetrations are in place.

B. Weather Limitations: Proceed with installation only when existing and forecasted weather conditions permit work to be performed according to manufacturer's written instructions and warranty requirements.

1. Apply materials within the range of ambient and substrate temperatures recommended by material manufacturers, but not below 50 deg F (10 deg C).
2. Apply materials within range of relative humidity recommended by manufacturer of each component, but not when relative humidity exceeds 85 percent, nor when temperatures are less than 5 deg F (3 deg C) above dew point.
3. Do not apply materials to damp or wet surfaces.
4. Do not apply primers, polyurethane foam in snow, rain, fog, or mist, or when such weather conditions are imminent during the application and curing period.
5. Do not apply polyurethane foam when wind conditions result in surface finish textures not complying with requirements.
6. Do not apply coatings when wind conditions prevent uniform coating application.

072120 Sprayed Insulation**2. PART 2 PRODUCTS****2.1 POLYURETHANE FOAM**

A. Polyurethane Foam: Rigid cellular polyurethane, spray applied, produced by the catalyzed chemical reaction of polyisocyanates with polyhydroxyls, with stabilizers, fire retardants, and blowing agents added; and complying with ASTM C 1029, Type I, as certified by a qualified independent testing agency. Foamed-In-Place Insulation <INSUL-36>: Medium-density, rigid or semi-rigid, closed cell polyurethane foam; foamed on-site, using blowing agent of water or non-ozone-depleting gas.

1. Basis-of-Design Product: Subject to compliance with requirements, provide Polyurethane Foam Enterprises LLC, Spraytite 178. Aged Thermal Resistance: R-value (RSI-value) of 6.7 (deg F hr sq ft)/Btu (1.2 (K sqm)/W), minimum, when tested at 1 inch (25.4 mm) thickness in accordance with ASTM C518 after aging for 180 days at 41 degrees F (23 degrees C). www.BASF-PFE.com or comparable product by one of the following:

a. The Dow Chemical Company Building & Construction www.Dow.com, STYROFOAM 2.0 pcf Spray Polyurethane Foam (SPF).

b. SWD Urethane Company.

2. In-Place Density: No less than 2.0 lb/cu.ft.; ASTM D 1622.

3. Surface-Burning Characteristic: As determined by testing identical products according to ASTM E 84 by a qualified testing agency. Identify products with appropriate markings of applicable testing agency.

a. Flame-Spread Index: 75 or less.

b. Smoke developed: 400.

4. Closed Cell Content: No less than 90 percent; ASTM D 6226.

5. Initial k-factor: (Btu in/ft² hr °F) 0.165 (R=6.1/in); ASTM C 518.

6. Permeance (perms): 1.82; ASTM E96.

7. Permeability (perm inch): 1.82 @ 1 inch SPF; ASTM E96.

a. 0.91 @ 2 inch SPF.

b. 0.61 @ 3 inch SPF.

c. 0.46 @ 4 inch SPF.

8. Air Permeance (L/s/m² @ 75 Pa): 0.000025; ASTM E 2178-01. when tested at intended thickness in accordance with ASTM E2178 or ASTM E283 at 1.5 psf (75 Pa).

9. Air Leakage (L/s/m²@ 75 Pa): 0.000025; ASTM E 283-99.

10. Dimensional Stability (% Volume Change); ASTM D 2126:

a. Dry Age 28 Days (158°F): +8 to +12 percent.

b. Freeze Age 14 Days (-20°F): +0.07 to -0.21 percent.

11. Compressive Strength: ASTM D 1621, lb/in², parallel: 26.

12. Tensile Strength: ASTM D 1623, lb/in², parallel: 55.

13. Thermal Conductivity: ASTM C 518, k-factor: 0.154.

14. Thermal Resistance: ASTM C 518, R-value per inch: 6.5.

15. Water Absorption: ASTM D 2842. Less than 2 percent by volume, maximum, when tested in accordance with ASTM D2842.

16. Water Vapor Permeance: Vapor retarder; 2 perm (115 ng/(Pa s sqm)), maximum, when tested at intended thickness in accordance with ASTM E96/E96M, desiccant method.

17. Products:

a. BASF Corporation; WALLTITE US: www.spf.basf.com.

b. Henry Company; PERMAX 2.0: www.henry.com/sle.

c. Icynene Inc; Icynene ProSeal MD-C-200v3: www.icynene.com.

d. Johns Manville; JM Corbond III Closed Cell Spray Polyurethane Foam: www.jm.com/sle.

e. Rhino Linings Corporation; DuraTite CC2.5: www.rhinolinings.com/sle.

f. Substitutions: See Section 01 6000 - Product Requirements.

2.2 AUXILIARY MATERIALS

A. Primer: Polyurethane foam manufacturer's standard factory-formulated primer.

B. Reinforcement: Flexible polyester or fiberglass mat of weight, type, and composition recommended by manufacturer for embedment in liquid coating.

C. Sealant: ASTM C 920, Class 25, Use NT, Grade NS, Type M, multi-component urethane, Type S, one-component, neutral-or acid-curing silicone, and as recommended by manufacturer for substrate and joint conditions and for compatibility with adjacent materials.

D. Sheet Flashing and Accessories: types recommended by manufacturer, provided at locations indicated and as recommended by manufacturer.

E. Vapor Barrier: Manufacturer's standard, spray applied.

072120 Sprayed Foamed in Place Insulation

3. PART 3 EXECUTION

3.1 EXAMINATION

A. Examine substrates, areas, and conditions under which insulation will be applied, with Installer present, for compliance with requirements. Begin installation only after unsatisfactory conditions have been corrected and substrates are dry.

3.2 SURFACE PREPARATION

- A. Clean and prepare substrate according to manufacturer's written instructions. Provide clean, dust-free, dew-free, and dry substrate.
- B. Remove grease, oil, form-release agents, curing compounds, and other contaminants from substrate.
- C. Cover and mask adjoining surfaces not receiving insulation to prevent overspray or spillage affecting other construction.
 - 1. Remove masking after polyurethane foam application.
- D. Prime substrate if recommended by manufacturer.
- E. Fill, cover, or tape joints and cracks in substrate that exceed a width of ¼ inch (6 mm).
Remove dust and dirt from joints and cracks before applying polyurethane foam.

3.3 POLYURETHANE FOAM APPLICATION

- A. General: Mix and apply polyurethane foam according to ASTM D 5469 and manufacturer's written instructions.
 - 1. Fill irregularities and areas of ponding.
 - 2. Apply the required full thickness of polyurethane foam in any specific area on same day.
 - 3. Apply only the area of polyurethane foam that can be covered on same day with required base coating.
 - 4. Apply polyurethane foam to avoid overspray beyond immediate area of work.
- B. Apply polyurethane foam in lift thicknesses not less than ½ inch (13 mm) and not more than 1-1/2 inches (38mm).
 - 1. Total Foam Thickness: 4 inches, except full depth where indicated.
- C. Uniformly apply total thickness of polyurethane foam indicated, but not less than 2 inch (50 mm), to a surface tolerance of ply ¼ inch (6 mm) and no minus.
- D. Apply polyurethane foam to penetrations, terminations, and vertical surfaces as indicated.
Unless otherwise indicated, extend polyurethane foam at least 4 inches (100 mm) above elevation of adjacent roof field.
- E. Surface Finish: Provide finished surface of polyurethane foam within the following range of surface textures as defined by ASTM D 5469:
 - 1. Texture: Smooth to rippling verge of popcorn.
- F. Remove and replace polyurethane foam not complying with minimum surface-texture limitations.
Remove defective thickness and prepare and reapply polyurethane foam with acceptable, uniform results.

3.4 CURING, PROTECTING, AND CLEANING

- A. Cure coatings according to manufacturer's written instructions, taking care to prevent contamination and damage during application stages and curing. Do not permit traffic on uncured coatings.
- B. Protect insulation from damage and wear during remainder of construction period.
- C. Clean overspray and spillage from adjacent construction using cleaning agents and procedures recommended by manufacturer of affected construction.

072130 Batt and Blanket Insulation

1. PART 1 GENERAL

1.1 SECTION INCLUDES

A. Batt insulation in interior walls construction (sound insulation).

1.2 RELATED SECTIONS

- A. Section 06 10 00 – Framing and Sheathing.
- B. Section 09 25 00 - Gypsum Board Systems.

1.3 REFERENCES

- A. ASTM C665 - Mineral Fiber Blanket Thermal Insulation for Light Frame Construction and Manufactured Housing.
- B. FS HH-I-521 - Insulation Blankets, Thermal, (Mineral Fiber for Ambient Temperatures).

1.4 PERFORMANCE REQUIREMENTS

- A. Materials of this Section shall provide continuity of thermal barrier at building enclosure elements.
- B. Materials of this Section shall provide continuity of vapor and air barrier at building enclosure elements.

072130 Batt and Blanket Insulation

1.5 COORDINATION

A. Coordinate Work under provisions of Section 01 31 00.

2. PART 2 PRODUCTS

2.1 MATERIALS

A. Batt Insulation: FS HH-I-521 Type I -conforming to the following:

Thermal Resistance: R-21 or as indicated

Size: As required

Facing: Unfaced

B. Sill Sealer Gasket: Cellular plastic in rolls of 50' or 100' in length (install at all base plates).

C. Sound rated insulation for interior wall construction ASTM C665 Type 1.

3. PART 3 EXECUTION

3.1 EXAMINATION

A. Verify site conditions under provisions of Section 01 31 13.

B. Verify that substrate, adjacent materials, and insulation are dry and ready to receive insulation.

3.2 INSTALLATION

A. Install in interior (sound insulation) and spaces without gaps or voids.

B. Trim insulation neatly to fit spaces. Lap joints between layers of insulation ½ width of batt.

C. Fit insulation tight in spaces and tight to exterior side of mechanical and electrical services within the plane of insulation.

Leave no gaps or voids.

D. Install sill sealer gasket all interior and exterior walls.

E. **Seal all penetrations of the air barrier (pipes, ducts, fans, lights, electrical boxes and other miscellaneous penetrations) to meet the air door testing.**

PART 1 GENERAL

- A. Contractor shall install Air infiltration barrier to all exterior surfaces.
- B. A 4" strip of self-adhesive material shall be applied around all windows.
- C. A "wind-wash" barrier shall be installed around the entire perimeter of the eaves at the top wall plate elevation to prevent insulation displacement.

PART 2 MATERIALS

- A. Air infiltration barrier shall be spunbonded olefin, high density polyethylene fiber wrap, conforming to HUD/FHA spec. UU-B-790-A, "Pactiv" brand "Green Guard, Rain drop", or equal. Install per manufacturer's specifications.

ASTM E - 84 results: Flame Spread: 5
 Fuel Contributed: 0
 Smoke Density: 10
- B. Adhesive back "ice and water shield material. Minimum 4" wide 30# weight.
- C. OSB or Gypboard Sheeting cut to size for use as wind-wash barrier at eaves.

PART 3 EXECUTION

- A. Install per manufacturer's instructions.
Apply in full wall height rolls (9') to outside of sheathing.
- B. Start at a corner with imprint facing outward. Staple at corner and roll around corner and cover entire wall surface with one continuous piece. Splicing shall be a minimum.
- C. Stable from top to bottom smoothing out wrinkles downward toward base plate. Staples shall be placed at a minimum of 30" o.c.
- D. Overlap base plate 6" - fasten material to foundation with approved adhesive.
- E. Overlap at splice one stud space.
- F. For window openings, cut an X from corner to corner of opening. Pull material in over framing and staple inside.
- G. Do not store where material can be exposed to sunlight. When installed, cover with siding material within 1 month.
- H. Apply 4" 30# ice and water shield around all vinyl windows.
 - 1. Clean all dirt and dust from sheathing surrounding window.
 - 2. Install material over all flanges starting with the bottom. Lap the side pieces over the bottom strip the full width of the material (4" each side). Install the top piece last and repeat lap procedure over side pieces. Installation shall leave window in watertight condition.

072700 - FIRE STOPPING

1. PART 1 GENERAL

1.1 SECTION INCLUDES

A. Fireproof fire stopping and fire-safing materials and accessories

1.2 RELATED SECTIONS

- A. Section 01 04 50: Cutting and Patching
- B. Section 01 12 00: Alteration Project Procedures
- C. Division 15: Mechanical
- D. Division 16: Electrical.

1.3 REFERENCES

- A. ASTM E84 - Test Method for Surface Burning Characteristics of Building Materials.
- B. ASTM E119 - Method for Fire Tests of Building Construction and Materials.
- C. ASTM E814 - Test Method of Fire Tests of Through Penetration Firestops.
- D. FM (Factory Mutual) - Fire Hazard Classifications.
- E. UL - Fire Hazard Classifications.
- F. UL 1479 - Fire Tests of Through-Penetration Firestops.
- G. WH (Warnock Hersey) - Certification Listings.

1.4 DEFINITION

A. Firestopping (Firesafing): A sealing or stuffing material or assembly placed in spaces between building materials to arrest the movement of smoke, heat, gases, or fire through wall or floor openings.

1.5 SYSTEM DESCRIPTION

- A. Firestopping Materials: ASTM E119, ASTM E814, UL 263, or UL 1479 to achieve a fire rating as noted on Drawings.
- B. Surface Burning: ASTM E84, UL 723 with a flame spread / smoke developed rating as required.
- C. Firestop all interruptions to fire rated assemblies, materials, and components.

1.6 REGULATORY REQUIREMENTS

A. Conform to applicable code for fire resistance ratings and surface burning characteristics.

1.7 ENVIRONMENTAL REQUIREMENTS

- A. Do not apply materials when temperature of substrate material and ambient air is below 60 degrees F.
- B. Maintain this minimum temperature before, during, and for 3 days after installation of materials.
- C. Provide ventilation in areas to receive solvent cured materials.

2. PART 2 PRODUCTS

2.1 SILICONE OR PLASTER COMPOUND

- A. Manufacturers:
 - 1. HILTI: CP6015, CP657 Firestop Brick at large openings. FSONE and other related products as suitable to application.
 - 2. Equal by STI, USG
 - 3. Substitutions: under provisions of section 01 60 00.

2.2 ACCESSORIES

- A. Primer: Type recommended by firestopping manufacturer for specific substrate surfaces.
- B. Dam Material:
 - 1. Mineral fiberboard.
 - 2. Mineral fiber matting.
 - 3. Sheet metal.
 - 4. Plywood or particle board.
 - 5. Alumina silicate fire board.
- C. Installation Accessories: Clips, collars, fasteners, temporary stops or dams, and other devices required to position and retain materials in place.

PART 3 EXECUTION

3.1 EXAMINATION

- A. Verify site conditions under provisions of Division 1.
- B. Verify openings are ready to receive the work of this section.

3.2 PREPARATION

- A. Clean substrate surfaces of dirt, dust, grease, oil, loose material, or other matter which may affect bond of firestopping material.
- B. Remove incompatible materials which may affect bond.
- C. Install backing or damming materials to arrest liquid material leakage.

3.3 APPLICATION

- A. Install material at floors or openings which contain penetrating sleeves, piping, ductwork, conduit and other items, requiring firestopping, (new and existing).
- B. Apply primer and materials in accordance with manufacturer's instructions.
- C. Apply firestopping material in sufficient thickness to achieve rating.
- D. Remove dam material after firestopping material has cured.

3.4 CLEANING

- A. Clean Work under provisions of Section 01 77 00.
- B. Clean adjacent surfaces of firestopping materials.

3.5 PROTECTION OF FINISHED WORK

- A. Protect finished Work under provisions of Section 01 50 00.
- B. Protect adjacent surfaces from damage by material installation.

073000 - ROOFING

073113 Asphalt Shingles

1. PART GENERAL

1.1 SECTION INCLUDES

- A. Granular surfaced asphalt shingle roofing.
- B. Ice dam protection, moisture shedding underlayment, eave, valley, and ridge protection.
- C. Associated metal flashings and accessories.
- D. Roof vents

1.2 RELATED SECTIONS

- A. Section 06 10 00 – Rough Carpentry: Roof sheathing
- B. Mechanical Divisions: Mechanical work projecting through roof.

1.3 REFERENCES

- A. ASTM A361/A361M - Steel Sheet, Zinc-Coated (Galvanized) by the Hot-Dip Process for Roofing and Siding.
- B. ASTM B209/B209M - Aluminum and Aluminum-Alloy Sheet and Plate.
- C. ASTM D225 - Asphalt Shingles Surfaced with Mineral Granules.
- D. ASTM D226 - Asphalt-Saturated Organic Felt Used in Roofing and Waterproofing.
- E. ASTM D228 - Testing Asphalt Roll Roofing, Cap Sheets and Shingles.
- F. ASTM D2178 - Asphalt Glass (Felt) Used in Roofing and Waterproofing.
- G. ASTM D2822 - Asphalt Roof Cement.
- H. ASTM D3462 - Asphalt Shingles Made From Glass Felt and Surfaced With Mineral Granules.
- I. ASTM D4586 - Asphalt Roof Cement, Asbestos Free.
- J. NRCA - Steep Roofing Manual.
- K. UL 55B - Class C Asphalt Organic-Felt Sheet Roofing and Shingles.
- L. UL 580 - Tests for Wind Uplift Resistance of Roof Assemblies.
- M. UL 790 - Tests for Fire Resistance of Roof Covering Materials.

1.4 SUBMITTALS FOR REVIEW

- A. Section 01 33 00 - Submittals: Procedures for submittals.
- B. Samples: Submit two samples of each shingle color indicating color range and finish texture/pattern.

1.5 QUALITY ASSURANCE

- A. Perform Work in accordance with NRCA Steep Roofing Manual.
- B. Guarantee
 - 1. Provide a 5 year notarized guarantee for all roofing work done under this section.
 - 2. Submit guarantee to the General Contractor or prior to final payment.
 - 3. Guarantee roof against leaks due to defects in the material or workmanship for a period of 5 years from the date of substantial completion.
 - 4. Provide all other limited warranties to the General Contractor or Owner.

1.6 REGULATORY REQUIREMENTS

- A. Conform to applicable code for shingle types specified.

1.7 ENVIRONMENTAL REQUIREMENTS

- A. Section 01 60 00 - Material and Equipment: Environmental conditions affecting products on site.
- B. Do not install eave edge protection and shingles when surface temperatures are below 45 degrees F.

1.8 EXTRA MATERIALS

- A. Section 01 77 00 - Project Closeout.
- B. Provide 5 sq ft of extra shingles of each color selected.

2. PART PRODUCTS

2.1 LAMINATED -ASPHALT SHINGLES

A. Manufacturers:

1. Basis of Design: GAF; Timberline ArmorShield II: www.gaf.com/sle.
2. Certaineed: www.certaineed.com.
3. Owens Corning Corp: www.owenscorning.com.
4. Substitutions: See Section 01 6000 - Product Requirements.

2.2 ASPHALT SHINGLES

A. Asphalt Shingles <SHINGLE-1>: Asphalt-coated fiber glass, mineral granule surfaced, complying with ASTM D3462/D3462M; Class A fire resistance.

1. Fire Resistance: Class A.
2. Wind Resistance: Class F, when tested in accordance with ASTM D3161/D3161M.
3. Warranted Wind Speed: 110 mph (177 km/h).
4. Algae Resistant.
5. Weight: 235-245 lb/100 sq ft (107-111 kg/sq m).
6. Self-sealing type.
7. Basis of Design:
 - a. Color: Weathered Wood; verify with G.C.
 - b. Lifetime limited warranty.

2.3 SHEET MATERIALS

A. Eave (Ice Dam) Protection Membrane <RF UNDLMT-5>: Self-adhering polymer-modified asphalt sheet complying with ASTM D1970; 40 mil (1 mm) total thickness; with strippable treated release paper and polyethylene sheet top surface.

B. Underlayment <RF UNDLMT-3>: ASTM D226, No. 15 unperforated asphalt saturated felts as recommended for use in waterproofing and in construction of built-up roofs. Synthetic non-asphaltic sheet, intended by manufacturer for mechanically fastened roofing underlayment without sealed seams.

1. Self Sealability: Passing nail sealability test specified in ASTM D1970/D1970M.
2. Flammability: Minimum of Class A, when tested in accordance with ASTM E108.
3. Ultraviolet Resistance and Weatherability: Approved in writing by manufacturer for exposure to weather for minimum of 6 months.
4. Low Temperature Flexibility: Passing test specified in ASTM D1970/D1970M.
5. Liquid Water Transmission: Passes ASTM D4869/D4869M.
6. Functional Temperature Range: Minus 70 degrees F (56.7 C) to 212 degrees F (100 C).
7. Fasteners: As specified by manufacturer and building code qualification report or approval, if any.
8. Manufacturers:
 - a. GAF; DeckArmor: www.gaf.com.
 - b. CertainTeed; Roofers' Select: www.certaineed.com.
 - c. Substitutions: See Section 01 6000 - Product Requirements.

2.4 ACCESSORIES

A. Nails: Standard round wire shingle type hot dipped zinc coated steel type, of sufficient length to penetrate through roof sheathing. 10 wire gage, 0.1019 inch (2.59 mm) shank diameter, 3/8 inch (9.5 mm) head diameter, of sufficient length to penetrate through roof sheathing or 3/4 inch (19 mm) into roof sheathing or decking.

B. Plastic Cement: [ASTM D2822,] Asphalt type with mineral fiber components, free of toxic solvents, capable of setting within 24 hours at temperatures of 75 degrees F (24 degrees C) and 50 percent RH.

C. Lap Cement: Fibrated cutback asphalt type, recommended for use in application of underlayment, free of toxic solvents.

D. Roof Vents -Ridge Vents: Certaineed: ShingleVent II, Charcoal. -R-61 Vent: Certaineed – as required.

Plastic, extruded with vent openings that do not permit direct water or weather entry; flanged to receive shingles; ShingleVent II Class A manufactured by Air Vent Inc. or approved equal.

1. Integral insect screen.
2. Net Free Area: 16 square inches of ventilation per linear foot.

E. Roof to Wall Vents: Coravent.

2.5 FLASHING MATERIALS- FABRICATION

A. Sheet Flashings: ASTM A361/A361M;26 gage thick pre-coated steel with minimum 1.25 oz/sq ft. Pre-formed and colored flashings (to match shingles) as required to protect roofing materials from physical damage and shed water galvanized coating; pre-coating of PVC color as selected. (Kickout Flashing). Hem exposed edges of flashings minimum 1/4 on underside.

1. Form flashings to protect roofing materials from physical damage and shed water.
2. Form sections square and accurate to profile, in maximum possible lengths, free from distortion or defects detrimental to appearance or performance.
3. At 'visual' areas, Sheet Metal: Prefinished galvanized steel, 0.018 inch/26 gage (0.45 mm) thick, minimum G90/Z275 hot-dipped galvanized; fluoropolymer coated, color as selected.
4. At 'non-visual', such as valley flashings, Sheet Metal: Galvanized steel, 0.018 inch/26 gage thick, minimum G90/Z275 hot-dipped galvanized.

B. Bituminous Paint: Acid and alkali resistant type; black color. Apply bituminous paint on concealed surfaces of flashings.

C. Nails: Standard round wire roofing type, hot dipped zinc coated steel; of sufficient length to penetrate through roof/wall sheathing.

D. Caulking: organic asphalt cement or approved equal.

3. PART EXECUTION

3.1 EXAMINATION

A. Section 01 31 13 - Coordination: Verification of existing conditions prior to beginning work.

B. Verify that roof penetrations and plumbing stacks are in place and flashed to deck surface.

C. Verify roof openings are correctly framed.

D. Verify deck surfaces are dry, free of ridges, warps, or voids.

3.4 PREPARATION

A. Fill knot holes and surface cracks with latex filler at areas of bonded eave protection.

B. Broom clean deck surfaces under eave protection and underlayment.

3.5 INSTALLATION - EAVE (ICE DAM) PROTECTION

A. Place eave edge and gable edge metal flashings tight with fascia boards. Weather lap joints 2 inches and seal with plastic cement. Secure flange with nails spaced 16 inches.

B. Apply rubberized asphalt/polyethylene sheet eave protection in accordance with manufacturer's instructions.

C. Starting from lower edge of starter strip, lay additional 36 inch wide strips of underlayment in lap cement, to produce a two ply membrane. Weather lap plies minimum 19 inches and nail in place.

Lap ends minimum 6 inches. Stagger end joints of each consecutive ply.

D. Extend eave protection membrane minimum 4 ft up-slope beyond interior face of exterior wall.

3.6 INSTALLATION - PROTECTIVE UNDERLAYMENT

A. Place one ply of underlayment over area not protected by eave protection, with ends and edges weather lapped minimum 6 inches. Stagger end laps of each consecutive layer. Nail in place.

B. Place a second ply of underlayment over first layer with ends and edges weather lapped minimum 6. Stagger end laps of each consecutive layer. Nail in place.

C. Install protective underlayment perpendicular to slope of roof and weather lap minimum 4 inches over eave protection.

D. Weather lap and seal watertight with plastic cement items projecting through or mounted on roof.

3.7 INSTALLATION - VALLEY PROTECTION

A. Place one layer of sheet metal flashing, minimum 24 inches wide, centered over open valleys and crimped to guide water. Weather lap joints minimum 2 inches. Nail in place minimum 18 inches oc, 1 inch from edges.

B. Apply rubberized asphalt/polyethylene sheet in valleys.

3.8 INSTALLATION - METAL FLASHING AND ACCESSORIES

A. Weather lap joints minimum 2 inches and seal weather tight with plastic cement.

B. Secure in place with nails at 16 inches oc. Conceal fastenings.

C. Flash and seal work weather tight, projecting through or mounted on roofing with plastic cement.

3.9 INSTALLATION - ASPHALT SHINGLES

- A. Install shingles in accordance with manufacturer's instructions
- B. Place shingles in straight coursing pattern with 5 inch weather exposure to produce double thickness over full roof area. Provide double course of shingles at eaves.
- C. Project first course of shingles 3/4 inch beyond fascia boards.
- D. Extend shingles 1/2 inch beyond face of gable edge fascia boards.
- E. Extend shingles on one slope across valley and fasten. Trim shingles from other slope 2 inches from valley center line to achieve closed cut valley, concealing the valley protection.
- F. Cap hips and ridges with individual shingles, maintaining 5 inch weather exposure. Place to avoid exposed nails.
- G. After installation, place one daub of plastic cement, one inch diameter under each individual shingle tab exposed to weather, to prevent lifting.
- H. Coordinate installation of roof mounted components or work projecting through roof with weather tight placement of counter flashing.
- I. Complete installation to provide weather tight service.
- J. Valley shingles shall be installed leaving the center valley metal exposed tapering from the bottom to the top. Shingles in the valleys are not to be nailed within 10" of the valley. Provide concealed caulking in these areas as required.
- K. Installation contractor shall install all required penetration covers such as plumbing stack boots etc. provided that these are on hand and ready to be installed at the time the area is being shingled.
- L. Contractor shall remove all excess materials from the roof at the time of completion. These are to be neatly stacked for return to supplier.
- M. Cleaning: Contractor shall regularly clean work area on the roof as well as the ground area. Full cleaning of all materials and debris shall be done at the completion of the work.

3.10 PROTECTION OF FINISHED WORK

- A. Section 01 77 00 - Project Closeout: Protecting installed work.
- B. Do not permit traffic over finished roof surface.

1. PART GENERAL

1.1 SECTION INCLUDES

- A. Preformed prefinished steel siding system for walls, related flashings and accessory components.
- B. Air infiltration barrier back-up over sheathed walls.
- C. Flashing

1.2 RELATED SECTIONS

- A. Section 04 20 00 – Concrete Unit Masonry
- B. Section 06 10 00 – Framing and Sheathing
- C. Section 07 46 50 - Preformed Metal Facia and Soffits.
- D. Section 09 90 00 - Painting.

1.3 REFERENCES

- A. ASTM A525/A525M - Steel Sheet, Zinc-Coated (Galvanized) by the Hot-Dip Process, General Requirements.
- B. ASTM A606 - Steel Sheet and Strip, Hot-Rolled and Cold-Rolled, High-Strength, Low-Alloy, with Improved Corrosion Resistance.
- C. ASTM A755/A755M - Steel Sheet, Metallic Coated by the Hot-Dip Process and Prepainted by the Coil Coating Process For Exterior Exposed Building Products.
- D. ASTM B209/B209M - Aluminum and Aluminum-Alloy Sheet and Plate.

1.4 SYSTEM DESCRIPTION

- A. System: Preformed and prefinished vinyl siding system of profile indicated; site assembled. Vinyl siding with vinyl window and door trim

A

1.5 DESIGN REQUIREMENTS

- A. Components: Design and size components to withstand dead and live loads caused by positive and negative wind pressure acting normal to plane of wall as calculated in accordance with building code.
- B. Maximum Allowable Deflection of Panel: 1/90 of span.
- C. Movement: Accommodate movement within system without damage to components or deterioration of seals, movement within system; movement between system and perimeter components when subject to seasonal temperature cycling; dynamic loading and release of loads; deflection of structural support framing.
- D. Drainage: Provide positive drainage to exterior for moisture entering or condensation occurring within panel system.
- E. Air Seal: **Seal all penetrations of the air barrier (pipes, ducts, fans, lights, electrical boxes and other miscellaneous penetrations) to meet the air door testing.**

1.6 SUBMITTALS FOR REVIEW

- A. Submit two samples of siding finish, illustrating finish color, sheen, and texture.

1.7 QUALITY ASSURANCE

- A. Contractor shall complete all installations using OSHA approved ladders, scaffold, harnesses or other required devices.
- B. Manufacturer: Company specializing in manufacturing the products specified in this section with minimum three years documented experience.
- C. Installer: Installer with 3 years minimum experience who has completed siding installations similar in material, design and extent with a record of successful performance.

1.8 DELIVERY, STORAGE, AND PROTECTION

- A. Section 01 60 00 - Material and Equipment: Transport, handle, store, and protect products.
- B. Protect panels from accelerated weathering by removing or venting sheet plastic shipping wrap.
- C. Store prefinished material off ground protected from weather, to prevent twisting, bending, or abrasion, and to provide ventilation. Slope metal sheets to ensure drainage.
- D. Prevent contact with materials which may cause discoloration or staining.

1.9 COORDINATION

- A. Coordinate the Work with installation of windows and doors.

1.10 EXTRA MATERIALS

- A. Furnish full lengths of siding in a quantity equal to 2 % of installed amount.

2. PART PRODUCTS

2.1 MANUFACTURERS

- A. Horizontal Vinyl Lap Siding EDCO double 6" ~~Steel Siding~~ – Colors as shown on drawings.
- B. Certaineed
- C. Window and Door Trim: Vinyl trim to be provided by vinyl manufacturer- Colors as selected by Owner.
- D. Substitutions under provisions of Section 01 60 00.

Vinyl siding to match Phase II

A

2.2 ACCESSORIES

- A. Gaskets: Manufacturer's standard type suitable for use with system, permanently resilient; ultraviolet and ozone resistant; color as selected.
- B. Sealants: Specified in Section 07900 color as selected.
- C. Accessory Components: Starter strips, trim, inside corners, outside corners, batten strips, drip edges, fixture bases, flashings, channels, trim sheet, etc.; of same material, thickness, and finish/color as siding or fascia/soffit; ribbed for strength and rigidity.
- D. Bituminous Paint: Asphalt base.
- E. Air Infiltration Barrier: Tyvek or prior approved equal.
- F. Flashing: Sheet Flashings: ASTM A361/A361M; 26 gage thick pre-coated steel with minimum 1.25 z/sq ft galvanized coating; pre-coating of PVC color as selected.
- G. Anchors: Galvanized steel or Stainless steel.

2.3 FABRICATION

- A. Form sections true to shape, accurate in size, square, and free from distortion or defects.
- B. Form pieces in longest practicable lengths.

3. PART EXECUTION

3.1 EXAMINATION

- A. Verify substrate framing.
- B. Verify that building framing members are ready to receive panel system.

3.2 INSTALLATION - INFILTRATION BARRIER

- A. Install 1 layer of infiltration barrier horizontally on walls to receive siding. Lap over and tape to window fins.
- B. Weather lap edges 6 inches ends minimum 6 inches, minimum.
- C. Stagger vertical joints of each layer.
- D. Securely nail in place.

3.3 INSTALLATION

- A. Install siding system on walls in accordance with manufacturer's instructions and ASTM D 4756/AAMA 1402. Install siding in maximum continuous lengths with minimum seams.
- B. Protect surfaces in contact with cementitious materials and dissimilar metals with bituminous paint. Allow to dry prior to installation.
- C. Fasten siding to structural supports; aligned, level, and plumb.
- D. Locate joints over supports.
- E. Conceal fasteners unless otherwise approved by Architect/Engineer.
- F. Seal and place gaskets to prevent weather penetration. Maintain neat appearance.
- G. Provide pre-finished matching sample to GC.

3.4 TOLERANCES

- A. Maximum Offset From True Alignment Between Adjacent Members Butting or In Line: 1/16 inch.
- B. Maximum Variation from Plane or Location Indicated on Drawings: 1/8 inch.

3.5 CLEANING

- A. Clean work under provisions of Section 01 77 00.
- B. Remove site cuttings from finish surfaces.
- C. Clean and wash prefinished surfaces with mild soap and water; rinse with clean water.

1. PART GENERAL

1.1 SECTION INCLUDES

A. Preformed, prefinished metal soffit and fascia system with related flashing, coping and accessory components, gutters, downspouts, splash blocks.

1.2 RELATED SECTIONS

- A. Section 06 10 00 – Rough Carpentry
- B. Section 07 46 50 - Preformed Metal Siding
- C. Section 07 90 00 - Joint Protection

1.3 REFERENCES

- A. ASTM A525/A525M - Steel Sheet, Zinc-Coated (Galvanized) by the Hot-Dip Process, General Requirements.
- B. ASTM A606 - Steel Sheet and Strip, Hot-Rolled and Cold-Rolled, High-Strength, Low-Alloy, with Improved Corrosion Resistance.
- C. ASTM A755/A755M - Steel Sheet, Metallic Coated by the Hot-Dip Process and Prepainted by the Coil Coating Process For Exterior Exposed Building Products.
- D. ASTM B209/B209M - Aluminum and Aluminum-Alloy Sheet and Plate.

1.4 SUBMITTALS FOR REVIEW

- A. Shop Drawings: Indicate thickness and dimension of parts, flashing and anchoring methods, and details and location of joints; including joints necessary to accommodate thermal movement.
- B. Samples:
 - 1. Two samples of each finish in color or colors selected, 3" x 5".

1.5 QUALITY ASSURANCE

- A. Manufacturer: Company specializing in manufacturing the products specified in this section with minimum five years documented experience.
- B. Installer: Acceptable to roofing manufacturer.

1.6 DELIVERY, STORAGE, AND PROTECTION

- A. Section 01 60 00 - Material and Equipment: Transport, handle, store, and protect products.
- B. Protect panels from accelerated weathering by removing or venting sheet plastic shipping wrap.
- C. Store prefinished material off ground protected from weather, to prevent twisting, bending, or abrasion, and to provide ventilation. Slope metal sheets to ensure drainage.
- D. Prevent contact with materials which may cause discoloration or staining.

2. PART PRODUCTS

2.1 MANUFACTURERS

- A. Soffit: EMCO 16" Panel width, typically at roof eaves as shown on drawings. Color: by Owner. All components to be of same color.
- B. Fascia, Coping, Accessories: manufacturer's standard: Color: by Owner.
- C. Gutters and downspouts: 5" Style "K" Gutter. Color: by Owner.
- D. Substitutions under provisions of section 01 60 00.

2.2 ACCESSORIES

- A. Fasteners:
 - 1. Concealed: non-corrosive, self-tapping screws appropriate for substrate provided.
- B. Sealants: Specified in Section 07 90 00, color as selected.
- C. Accessory Components: Starter strips, trim, drip edges, channels, trim sheet, etc.: of same material and finish as roofing.
- D. Splash blocks: precast concrete 4' x 1'.
- E. Field Touch-up Paint: As recommended by manufacturer.

2.3 FINISHES

- A. Coil-coated or spray applied fluorocarbon resin; color by Owner to match other components.
 - 1. Number of coats: As required by color selected.
 - 2. Provide factory applied strippable plastic film for protection during fabrication and installation.

3. PART EXECUTION

3.1 EXAMINATION

A. Examine the areas and conditions under which materials are to be installed and notify the contractor in writing of conditions detrimental to the proper and timely completion of the work.

Do not proceed with the work until unsatisfactory conditions have been corrected.

B. Surfaces to receive panels shall be even, smooth, sound, clean, dry, free of ice and snow, and free from defects.

C. Verify that roof openings, curbs, pipes, sleeves, ducts, vents, and other penetrations through roof substrate are complete.

3.2 PREPARATION

A. Obtain field measurements prior to completion of manufacturing and finishing. When field measurements are not possible, provide method of installation which will allow minor adjustment in the field.

3.3 INSTALLATION

A. Install soffit and fascia systems plumb, level and true in accordance with manufacturer's instructions, final shop drawings, and SMACNA Architectural Sheet Metal manual and standard practices.

B. Install starter and edge strips before underlayment is installed.

C. Completed system shall be free from over-bending, deforming, stretching, distortion, waves, and buckles.

D. All materials to be installed to allow for proper movement as recommended by the manufacturer. Joints in fascia are to be lapped to prevent water penetration. **Fascia material shall not be "face nailed"**.

E. Installation contractor shall coordinate with other trades to allow proper openings for venting devices etc. which terminate in the soffit.

3.4 ADJUSTING AND CLEANING

A. Repair panels with minor damage.

B. Remove panels damaged beyond repair and replace with new panels to match adjacent undamaged panels.

C. Clean exposed panel surfaces promptly after installation in accordance with recommendations of panel and coating manufacturers.

D. Remove protective film immediately after installation.

PART 1 GENERAL

1.1 SECTION INCLUDES

- A. Elastomeric roofing membrane, adhered conventional application.
- B. Insulation, tapered.
- C. Flashings.
- D. Roofing cant strips and stack boots.

1.2 RELATED REQUIREMENTS

- A. Section 06 1000 - Rough Carpentry: Wood nailers and curbs.

1.3 REFERENCE STANDARDS

- A. ASTM C1289 - Standard Specification for Faced Rigid Cellular Polyisocyanurate Thermal Insulation Board; 2014.
- B. ASTM D412 - Standard Test Methods for Vulcanized Rubber and Thermoplastic Elastomers--Tension; 2006a (Reapproved 2015a).
- C. ASTM D624 - Standard Test Method for Tear Strength of Conventional Vulcanized Rubber and Thermoplastic Elastomers; 2000 (Reapproved 2012).
- D. ASTM D746 - Standard Test Method for Brittleness Temperature of Plastics and Elastomers by Impact; 2014.
- E. ASTM D4637/D4637M - Standard Specification for EPDM Sheet Used in Single-Ply Roof Membrane; 2015.
- F. ASTM E96/E96M - Standard Test Methods for Water Vapor Transmission of Materials; 2014.
- G. FM DS 1-28 - Wind Design; 2007.
- H. UL (DIR) - Online Certifications Directory; current listings at database.ul.com.

1.4 SUBMITTALS

- A. See Section 01 3000 - Administrative Requirements - Administrative Requirements, for submittal procedures.
- B. Product Data: Provide data indicating membrane materials, flashing materials, insulation, and fasteners.
- C. Shop Drawings: Indicate joint or termination detail conditions, conditions of interface with other materials, setting plan for tapered insulation, and paver layout.
- D. Warranty: Submit manufacturer warranty and ensure forms have been completed in Owner's name and registered with manufacturer.

1.5 QUALITY ASSURANCE

- A. Manufacturer Qualifications: Company specializing in manufacturing the products specified in this section with minimum three years of documented experience.
- B. Installer Qualifications: Company specializing in performing the work of this section with minimum three years documented experience.

1.6 DELIVERY, STORAGE, AND HANDLING

- A. Deliver products in manufacturer's original containers, dry, undamaged, with seals and labels intact.
- B. Store products in weather protected environment, clear of ground and moisture.
- C. Protect foam insulation from direct exposure to sunlight.

1.7 FIELD CONDITIONS

- A. Do not apply roofing membrane during unsuitable weather.
- B. Do not apply roofing membrane when ambient temperature is below 40 degrees F (5 degrees C) or above 100 degrees F (38 degrees C).
- C. Do not apply roofing membrane to damp or frozen deck surface or when precipitation is expected or occurring.
- D. Do not expose materials vulnerable to water or sun damage in quantities greater than can be weatherproofed the same day.

1.8 WARRANTY

- A. See Section 01 7800 - Closeout Submittals, for additional warranty requirements.
- B. Correct defective Work within a two year period after Date of Substantial Completion.
- C. General Warranty: The warranties specified in this Article shall not deprive the Owner of other rights the Owner may have under other provisions of the Contract Documents and shall be in addition to, and run concurrent with, other warranties made by the Contractor under requirements of the Contract Documents.
- D. Provide 20 year manufacturer's material and labor warranty to cover failure to prevent penetration of water.

PART 2 PRODUCTS

2.1 MANUFACTURERS

A. EPDM Membrane Materials:

1. Carlisle Roofing Systems, Inc; Sure-Seal EPDM: www.carlisle-syntec.com.
2. Firestone Building Products, LLC: www.firestonebpco.com.
3. GenFlex Roofing Systems, LLC: www.genflex.com.
4. Versico, a division of Carlisle Construction Materials Inc; VersiGard EPDM: www.versico.com/sle.
5. Substitutions: See Section 01 6000 - Product Requirements.

B. Insulation:

1. Dow Chemical Company: www.dow.com.
2. GAF: www.gaf.com/sle.
3. Hunter Panels, LLC: www.hpanels.com.
4. Owens Corning Corporation: www.owenscorning.com.
5. Insulation manufactured by the membrane manufacturer is approved.
6. Substitutions: See Section 01 6000 - Product Requirements.

2.2 ROOFING - UNBALLASTED APPLICATIONS

A. Elastomeric Membrane Roofing <EPDM-2>: One ply membrane, fully adhered, over insulation.

B. Roofing Assembly Requirements:

1. Roof Covering External Fire Resistance Classification: UL (DIR) certified Class A.
2. Factory Mutual Classification: Class I and windstorm resistance of I-75, in accordance with FM DS 1-28.

C. Acceptable Insulation Types - Constant Thickness Application: Any of the types specified.

1. Minimum 2 layers of polyisocyanurate board.

D. Acceptable Insulation Types - Tapered Application: Any of the types specified.

1. Tapered polyisocyanurate board.

2.3 ROOFING MEMBRANE AND ASSOCIATED MATERIALS

A. Membrane: Ethylene-propylene-diene-terpolymer (EPDM); non-reinforced; complying with minimum properties of ASTM D4637.

1. Thickness: 0.060 inch (1.5 mm).
2. Color: Black.
3. Tensile Strength: 1,400 psi (10.0 MPa), measured in accordance with ASTM D412.
4. Ultimate Elongation: 300 percent, measured in accordance with ASTM D412.
5. Tear Strength: 150 lbf/in (26.3 kN/m), measured in accordance with ASTM D624.
6. Water Vapor Permeability: 0.5 perm inch (0.33 ng/(Pa s m)), measured in accordance with ASTM E96/E96M.
7. Brittleness Temperature: -49 degrees F (-45 degrees C), measured in accordance with 1.

B. Seaming Materials: As recommended by membrane manufacturer.

C. Flexible Flashing Material: Same material as membrane; conforming to the following:

1. Thickness: 60 mil (1.5 mm).
2. Color: Black.

2.4 INSULATION

A. Polyisocyanurate Board Insulation: Rigid cellular foam, complying with ASTM C1289, Type II, Class 1, cellulose felt or glass fiber mat both faces; Grade 2 and with the following characteristics:

1. System Identification:
 - a. <INSUL-53>: Tapered insulation over roof deck; no constant thickness insulation.
2. Compressive Strength: 20 psi (138 kPa)
3. Tapered Board: Slope as indicated; minimum thickness 1/2 inch (12.7 mm); fabricate of fewest layers possible.
4. Board Edges: Square.

2.5 ACCESSORIES

A. Stack Boots: Prefabricated flexible boot and collar for pipe stacks through membrane; same material as membrane.

B. Cant and Edge Strips: Wood fiberboard, compatible with roofing materials; cants formed to 45 degree angle.

C. Membrane Adhesive: As recommended by membrane manufacturer.

D. Surface Conditioner for Adhesives: Compatible with membrane and adhesives.

E. Thinners and Cleaners: As recommended by adhesive manufacturer, compatible with membrane.

F. Insulation Adhesive: As recommended by insulation manufacturer.

G. Sealants: As recommended by membrane manufacturer.

PART 3 EXECUTION

3.1 EXAMINATION

- A. Verify that surfaces and site conditions are ready to receive work.
- B. Verify deck is supported and secure.
- C. Verify deck is clean and smooth, flat, free of depressions, waves, or projections, properly sloped and suitable for installation of roof system.
- D. Verify deck surfaces are dry and free of snow or ice.
- E. Verify that roof openings, curbs, and penetrations through roof are solidly set, and cant strips are in place.

3.2 WOOD DECK PREPARATION

- A. Verify flatness and tightness of joints of wood decking. Fill knot holes with latex filler.
- B. Confirm dry deck by moisture meter with 12 percent moisture maximum.

3.03 INSULATION - UNDER MEMBRANE

- A. Attachment of Insulation: Embed insulation in adhesive in full contact, in accordance with roofing and insulation manufacturers' instructions.
- B. Lay subsequent layers of insulation with joints staggered minimum 6 inch (150 mm) from joints of preceding layer.
- C. Place tapered insulation to the required slope pattern in accordance with manufacturer's instructions.
- D. Lay boards with edges in moderate contact without forcing. Cut insulation to fit neatly to perimeter blocking and around penetrations through roof.
- E. At roof drains, use factory-tapered boards to slope down to roof drains over a distance of 18 inches (450 mm).
- F. Do not apply more insulation than can be covered with membrane in same day.

3.4 MEMBRANE APPLICATION

- A. Roll out membrane, free from wrinkles or tears. Place sheet into place without stretching.
- B. Shingle joints on sloped substrate in direction of drainage.
- C. Fully Adhered Application: Apply adhesive to substrate at manufacturer's recommended rate. Fully embed membrane in adhesive except in areas directly over or within 3 inches of expansion joints. Fully adhere one roll before proceeding to adjacent rolls.
- D. Overlap edges and ends and seal seams by contact adhesive, minimum 3 inches (75 mm). Seal permanently waterproof. Apply uniform bead of sealant to joint edge.
- E. At intersections with vertical surfaces:
 - 1. Extend membrane over cant strips and up a minimum of 4 inches (100 mm) onto vertical surfaces.
 - 2. Fully adhere flexible flashing over membrane and up to nailing strips.
- F. Around roof penetrations, seal flanges and flashings with flexible flashing.
- G. Coordinate installation of roof drains and sumps and related flashings.

3.5 CLEANING

- A. Remove bituminous markings from finished surfaces.
- B. In areas where finished surfaces are soiled by work of this section, consult manufacturer of surfaces for cleaning advice and conform to their documented instructions.
- C. Repair or replace defaced or damaged finishes caused by work of this section.

3.6 PROTECTION

- A. Protect installed roofing and flashings from construction operations.
- B. Where traffic must continue over finished roof membrane, protect surfaces using durable materials.

PART 1 GENERAL

1.1 WORK INCLUDED

- A. Metal counter flashings. (prefinished metal)
- B. Built-in metal (prefinished metal).
- C. Miscellaneous sheet metal accessories.
- D. Counterflashings at roof mounted vent stacks.
- E. Kickout Flashing at wall/roof intersection

1.2 QUALITY ASSURANCE

- A. Applicator: Company specializing in sheet metal flashing work with 3 years minimum experience.

1.3 STORAGE AND HANDLING

- A. Store products under provisions of Section 01 60 00.
- B. Stack preformed and prefinished material to prevent twisting, bending, or abrasion, and to provide ventilation.
- C. Prevent contact with materials during storage which may cause discoloration, staining, or damage.

2. PART 2 PRODUCTS

2.1 SHEET MATERIALS

- A. Pre-coated Galvanized Steel: ASTM A525, G90; 24 gage core steel, shop pre-coated with flouropolymer coating.
 - 1. Copper Sales
 - 2. Substitutions under provisions of Section 01 60 00.

2.1 ACCESSORIES

- A. Fastener: Galvanized steel with soft neoprene washers at exposed fasteners. Finish exposed fasteners same as flashing metal.
- B. Underlayment: ASTM D266; No. 15 asphalt saturated roofing felt.
- C. Sealant: manufacturers' recommended.

2.2 FABRICATION

- A. Form sections true to shape, accurate in size, square, and free from distortion or defects.
- B. Fabricate cleats and starter strips of galvanized type sheet metals, same material as sheet, continuous interlockable with sheet.
- C. Form pieces in longest practical lengths.
- D. Hem exposed edges on underside 1/2 inch; miter and seam corners.
- E. Form material with standing seam.
- F. Fabricate corners from one piece with minimum 18 inch long legs; seam for rigidity, seal with sealant.
- G. Fabricate vertical faces with bottom edge formed outward 1/4 inch and hemmed to form drip.

3. PART 3 EXECUTION

3.1 INSPECTION

- A. Verify roof openings, pipes, sleeves, ducts, or vents through roof are solidly set, and nailing strips located.
- B. Verify membrane termination and base flashing are in place, sealed, and secure.
- C. Beginning of installation means acceptance of existing conditions.

3.2 PREPARATION

- A. Field measure site conditions prior to fabricating work.
- B. Install starter and edge strips, and cleats before starting installation.
- C. Secure flashing in place using concealed fasteners. Use exposed fasteners only in locations approved by Architect/Engineer.
- D. Seam and seal all joints.
- E. Apply plastic cement compound between metal flashing and felt flashing.
- F. Fit flashing tight in place. Make corners square, surfaces true and straight in planes, and lines accurate to profiles.
- G. Seal metal joints watertight.

3.3 INSTALLATION

- A. Conform to drawing details included in SMACNA and NRCA manual.

PART 1 GENERAL

1.1 SECTION INCLUDES

- A. Preparing sealant substrate surfaces.
- B. Sealant and backing.

1.2 REFERENCES

- A. ANSI/ASTM D1565 - Flexible Cellular Materials - Vinyl Chloride Polymers and Copolymers (Open-Cell Foam).
- B. FS TT-S-00230 - Sealing Compound: Elastomeric Type, Single Component.
- C. FS TT-S-001543 - Sealing Compound, Silicone Rubber Base.
- D. SWI (Sealing and Waterproofers Institute) - Sealant and Caulking Guide Specification.

1.3 SUBMITTALS

- A. Submit product data under provisions of Section 01 33 00.
- B. Submit product data indicating sealant chemical characteristics, performance criteria, limitations, color availability.
- C. Submit samples under provisions of Section 01 33 00.
- D. Submit manufacturer's installation instructions under provisions of Section 01 33 00.

1.4 QUALITY ASSURANCE

- A. Manufacturer: Company specializing in manufacturing the products specified in this Section with minimum three years experience.
- B. Applicator: Company specializing in applying the work of this Section with minimum three years experience.
- C. Conform to Sealant and Waterproofers Institute requirements for materials and installation.
- D. **THIS PROJECT IS PARTICIPATING IN IMPLEMENTING MINNESOTA HOUSING FINANCE AGENCY SUSTAINABLE HOUSING POLICIES, most notably the MN Overlay to the Green Communities Criteria, which can be referenced at www.greencommunitiesonline.org/minnesota. These include the required criteria as stated below as a minimum acceptable standard prior to approval.**
 - 1. All interior adhesives and sealants shall be of low- or no-VOC composition, except where use of such materials would void a required construction warranty:
 - a. Adhesives must comply with Rule 1168 of the South Coast Air Quality Management District for VOC Limits.
 - b. All caulks and sealants must comply with applicable Regulations.

1.5 ENVIRONMENTAL REQUIREMENTS

- A. Do not install solvent curing sealants in enclosed building spaces.
- B. Maintain temperature and humidity recommended by the sealant manufacturer during and after installation.

1.6 SEQUENCING AND SCHEDULING

- A. Coordinate the work of this Section with all Sections referencing this Section.

1.7 WARRANTY

- A. Provide five year warranty under provisions of Section 01 77 00.
- B. Warranty: Include coverage of installed sealants and accessories which fail to achieve air tight and watertight seal, exhibit loss of adhesion or cohesion, or do not cure.
 - 1. Installer: Installer's standard form in which Installer agrees to repair or replace elastomeric joint sealants that do not comply with performance and other requirements specified in this Section within 2 years from date of Substantial Completion.
 - 2. Manufacturer: Manufacturer's standard form in which manufacturer agrees to furnish elastomeric joint sealants to repair or replace those that do not comply with performance and other requirements specified in this Section within 5 years from date of Substantial Completion.

2. PART 2 PRODUCTS

2.1 SEALANTS

- A. Polyurethane Sealant: FS TT-S-00230, Type II - non-sag, Class A; color to match other components.
- B. Polyurethane Sealant: Multi-component, chemical curing, non-staining, non-bleeding, capable of continuous water immersion, non-sagging, self-levelling type; color to match components.
 - Elongation Capability 25 percent
 - Service Temperature Range -40 to 180 degrees F
 - Shore A Hardness Range 20 to 35
- C. Silicone Sealant: FS TT-S-01543, Class A, low modulus type; color to match components.
- D. Silicone Sealant: Single component, fungus resistant, chemical curing, non-sagging, non-staining, non-bleeding.
 - Elongation Capability 25 percent
 - Service Temperature Range -65 to 180 degrees F
 - Shore A Hardness Range 15 to 25

2.2 ACCESSORIES

- A. Primer: Non-staining type, recommended by sealant manufacturer to suit application.
- B. Joint Cleaner: Non-corrosive and non-staining type, recommended by sealant manufacturer; compatible with joint forming materials.
- C. Joint Backing: ANSI/ASTM D1056; round, open cell polyethylene foam rod; oversized 30 to 50 percent larger than joint width.
- D. Bond Breaker: Pressure sensitive tape recommended by sealant manufacturer to suit application.

3. PART 3 EXECUTION

3.1 EXAMINATION

- A. Verify that joint openings are ready to receive work and field measurements are as shown on Drawings and recommended by the manufacturer.
- B. Beginning of installation means installer accepts existing substrate.

3.2 PREPARATION

- A. Clean and prime joints in accordance with manufacturer's instructions.
- B. Remove loose materials and foreign matter which might impair adhesion of sealant.
- C. Verify that joint backing and release tapes are compatible with sealant.
- D. Perform preparation in accordance with ASTM C804 for solvent release sealants.
- E. Protect elements surrounding the work of this Section from damage or disfiguration.

3.3 INSTALLATION

- A. Install sealant in accordance with manufacturer's instructions.
- B. Measure joint dimensions and size materials to achieve required width/depth ratios.
- C. Install joint backing to achieve a neck dimension no greater than 1/3 the joint width.
- D. Install bond breaker where joint backing is not used.
- E. Apply sealant within recommended application temperature ranges. Consult manufacturer when sealant cannot be applied within these temperature ranges.
- F. Install sealant free of air pockets, foreign embedded matter, ridges, and sags.
- G. Tool joints concave as detailed.
- H. **Seal all penetrations of the air barrier (pipes, ducts, fans, lights, electrical boxes and other miscellaneous penetrations) to meet the air door testing.**
- I. **Install sealant under bottom plates to seal joint between plates and sub floor.**

3.4 CLEANING AND REPAIRING

- A. Clean work under provisions of Section 01 77 00.
- B. Clean adjacent soiled surfaces.
- C. Repair or replace defaced or disfigured finishes caused by work of this Section.

3.5 PROTECTION OF FINISHED WORK

- A. Protect finished installation under provisions of Section 01 50 00.
- B. Protect sealants until cured.

PART 1 GENERAL

1.1 SUMMARY

A. This section covers the furnishing of all labor; equipment and materials to complete the prefinished steel door frames, as shown on the drawings and as specified herein.

B. Related Sections:

1. Section 03 30 00 – Cast-In-Place Concrete: Placement of anchors into masonry wall construction.
2. Section 04 20 00 – Unit Masonry: Masonry grout fill of metal frames & placement of anchors into masonry wall construction.
3. Section 06 20 00 – Finish Carpentry: Installation of doors and frames.
4. Section 08 71 00 – Door Hardware: Hardware, silencers, and weather-stripping.

1.2 REFERENCES

A. American National Standards Institute:

1. ANSI 115.1 Specification for Steel Door and Frame Preparation for Hardware.
2. ANSI/SDI Standard A224.1 Test Procedure and Test Criteria for Prime Painted Steel Surfaces for Steel Doors and Frames.
3. ANSI A250.8 – Recommended Specifications for Standard Steel Doors and Frames.

B. ASTM International:

1. ASTM A366 Standard Specification for Commercial Steel (CS) Sheet, Carbon (0.15 Maximum Percent) Cold-Rolled.
2. ASTM A653/A653M – Standard Specification for Steel Sheet, Zinc-Coated (Galvanized or Zinc-Iron Alloy-Coated (Galvannealed) by the Hot-Dip Process.
3. ASTM A924 Standard Specification for General Requirements for steel sheet, metallic Coated by the Hot-Dip process.
4. ASTM B117 Standard Practice for Operating Salt Spray (Fog) Apparatus.
5. ASTM D714 Standard Test Method for Evaluating Degree of Blistering of Paints.
6. ASTM D1654 Standard Test Method for Evaluation of Painted or Coated Specimens Subjected to Corrosive Environments.
7. ASTM D1735 Standard Practice for Testing Water Resistance of Coatings Using Water Fog Apparatus.
8. ASTM D3363 Standard Test Method for Film Hardness by Pencil Test.

C. National Fire Protection Association:

1. NFPA 80 – Standard for fire Doors, Fire Windows.
2. NFPA 252 – Standard Methods of Fire Tests of Door Assemblies.

D. Underwriters Laboratories, Inc.:

1. UL 10B – Fire Tests of Door Assemblies.
2. UL 10C – Positive Pressure Fire Tests of Door Assemblies.
3. UL 1784 – Air Leakage Tests of Door Assemblies.

1.3 SUBMITTALS

A. Section 01 33 00 – Submittal Procedures: Submittal procedures.

B. Shop Drawings: Indicate frame elevations, material thickness, reinforcement, anchor types and spacing, exposed fasteners, hardware locations, arrangement, and frame finish.

C. Product Data: Submit frame configuration and finishes.

D. Samples: Submit 2x3 samples of factory stocked colors of prefinished components.

1.4 QUALITY ASSURANCE

A. Conform to requirements of ANSI A250.8.

B. FC. Smoke and Draft Control Door Frames: Tested in accordance with UL 1784.

1. Air Leakage: Maximum 3.0 cfm/sf of door opening with 0.10 inch water gage pressure differential.

C. Attach label from agency approved by authority having jurisdiction to identify each fire rated frame.

1. Attach smoke label to smoke and draft control frames.

1.5 QUALIFICATIONS

A. Manufacturer: Company specializing in manufacturing products specified in this section with min. 3 years documented experience.

1.6 DELIVERY, STORAGE, AND HANDLING

A. Section 01 60 00 – Product Requirements: Product storage and handling requirements.

B. Protect frames with resilient packaging and crate doors for delivery to site.

C. Accept frames on site in manufacturer's original, unopened, undamaged containers with identification labels intact. Inspect for damage.

D. At site, uncrate frames and store wood sills or floor in a manner that will prevent rust and damage. Store under cover and off ground in manner that will prevent rust and damage. Break seal on-site to permit ventilation. Protect materials from exposure to harmful weather and at temperature conditions recommended by manufacturer.

081100 - PREFINISHED STEEL DOORS & FRAMES

1.7 COORDINATION

- A. Section 01 31 13 – Administrative Requirements: coordination and project conditions.
- B. Coordinate Work with frame opening construction and hardware installation.
- C. Sequence installation to accommodate required door hardware electric wire connections.

1.8 PROJECT CONDITIONS

- A. Field Measurements: Verify actual measurements/openings by field measurements before fabrication. Show recorded measurements on shop drawings. Coordinate field measurements and fabrication schedule with construction progress schedule to avoid construction delays.

2. PART 2 PRODUCTS

2.1 PREFINISHED STEEL FRAMES

A. Manufacturer:

- 1. Rediframe Door Frames.
 - a. Acceptable Equals
 - 1) Slimfold Manufacturing Co.
 - 2) Chicago Metallic Door Systems
 - 3) Timely
- 2. Therma Tru Doors, Model Adjusta-Fit.
- 3. Substitutions: Section 01 60 00 – Product Requirements.

B. Product Description:

- 1. Type: Rediframe kerf profile.
 - a. Casing: S56 Steel Colonial Casing, 24 gauge.
 - 1) Provide interior casing components and required attachment clips for Therma Tru frames.
 - b. Finish: Factory prefinished – color by Architect.
 - c. Silencers: Felt-type, manufacturer’s standard.
 - d. Label frames according to UL fire-rating as scheduled on drawings.
- 2. Type: Adjusta-Fit, Commercial grade Steel Frame.
 - a. Base frame Gauge: 16 gauge Rated Frame Construction: Conform to NFPA 252.
 - b. Closure frame Gauge: 22 ga.
 - c. Finish: Factory applied.
 - d. Silencers: Felt-type, manufacturer’s standard.
 - e. Weatherstrip: Manufacturer’s standard foam filled compression weatherstrip, installed in kerf of frame.
 - f. Threshold: Barrier-free ADA-compliant type of extruded aluminum, mill finish with safety ribs, 4 inches wide by ½ inch height; ribbed extruded vinyl sweep across door bottom.
 - g. Label frames according to UL fire-rating as scheduled on drawings.

C. Red-Frame Components

- 1. Redi-Frame: e-side knock-down frame with die-cut mitered steel, prepared for field installed pre-finished casing where indicated on drawings.
- 2. Wood stud jamb anchors unless otherwise indicated or required.
- 3. Hinge Reinforcements: 14 gage hot dipped galvanized (G60) steel to ASTM A653 (10 gage equivalent number of threads, SDI-107).
- 4. Strikes and Deadbolt Covers and Dust Box: 18 gage commercial quality cold rolled steel to ASTM A366.
- 5. Door Closer Reinforcement: Steel or aluminum in accordance with manufacturer’s standard.
 - a. Standard arm mounting: Aluminum extrusion 6065-T5 alloy in accordance with manufacturer’s standard.
 - 1) Door Guard: Aluminum extrusion 6065-T5 alloy in accordance with manufacturer’s standard.
 - b. Parallel arm mounting: 16 gage galvanized (A40) steel per ASMT A653.
- 6. Casing Corner Alignment Clips: Prepainted 22 gage ASTM A366 commercial quality cold rolled steel.
- 7. Interior Frames: Install felt silencers on the header and strike jamb. Single door opening 1 per header, 2 per strike jamb. Pair door opening, 2 per header.
- 8. Fire-Rated Frames: Kerf weatherstrip and smoke gasket material to seal opening. Schlegel QDS500 is acceptable.
- 9. Fasteners: In accordance with manufacturer’s standards, to comply with labeling agency for fire-rated frames.
 - a. Fastener shall be a minimum of ½ inch longer than combined thickness of drywall.
 - 1) 1-1/4 inch minimum Type “S” bugle-headed self-tapping screws.
 - 2) 1-1/4 inch minimum drywall screws (course threaded).

081100 - PREFINISHED STEEL DOORS & FRAMES

2.1 PREFINISHED STEEL FRAMES

D. Adjusta-Fit Frame Components:

1. Construction: Two-piece frames constructed of galvanized steel conforming to ASTM A653, commercial quality, with A 40 coating.
2. Profile: Split Adjustable pre-hung steel frame; interlocking base and closure profiles for ½ inch throat dimension adjustment; manufacturer's standard throat dimensions to accommodate wall thicknesses 3-3/8 inches to 10 inches.
3. Single rabbet; rabbet for 1-3/4 inch door thickness on stop side of frame, 5/8 inch high stop with kerf for weatherstrip, 1-13/16 inches wide trim face, no return legs.
4. Corners: Butted at intersections of head and jambs.
5. Factory primer with rust inhibiting primer. Prime painted system shall be tested at a recognized independent laboratory in accordance with ANSI/SDI standard A.250.10 and meet the acceptance criteria as outlined in that document and required by the architect or owner.
6. Painted finish material: Comply with ANSI A250.3 test procedures and acceptance criteria for factory applied finish for steel frames.
7. Color to be selected from manufacturer's standard color palette.
8. Hardware preparation: Frames prepared for hardware, reinforced as follows:
 - a. Hinges: Stamped integral pocket provided for full 4-inches by 4-inches, located in accordance with manufacturer's specifications.
 - b. Strike: Reinforcement integral with frame, commercial strike option of 4-7/8" 115.1 ANSI prep.
 - c. Strike adapter plate for 'T' strike or full lip strike, both with or without deadbolt.
 - d. Surface-mounted hardware: Reinforcement of minimum 16 gauge provided for other door hardware.

2.2 ACCESSORIES

- A. Silencers: Specified in Section 08 71 00.
- B. Weatherstripping: Specified in Section 08 71 00.

2.3 FABRICATION

- A. Fabricate roll formed or press broken frame to standard RediFrame kerf profile.
- B. Coordinate machined hinge jambs for doorframes with hardware section 08 70 00.
- C. Prepare frames for silencers. Provide three single silencers for single doors and mullions of double doors on strike side. Provide two single silencers on frame had at double doors without mullions.
- D. Attach fire rated label to each fire rated frame.
- E.

2.4 SHOP FINISHING

- A. RediFrame Factory Finish: Finish paint or prime paint is baked-on enamel electrostatically applied over chemically treated, cold rolled or galvanized steel; dry film thickness is +1.0 mil.
 1. Factory finish paint shall pass 200 hour salt spray test in accordance with ASTM B117 and 700 hour humidity test in accordance with ASTM D1735 with no blistering.
 2. Paint hardness shall meet calibrated pencil lead test to ASTM D3363.

3. PART 3 EXECUTION

3.1 EXAMINATION

- A. Section 01 31 13 – Coordination & Meetings: Coordination and project conditions.
- B. Verify opening sizes and tolerances are acceptable and that substrate conditions, which have been previously installed under other sections, are acceptable for product installation in accordance with manufacturer's instructions. Select fasteners of adequate type, number and quality to perform the intended functions.

081100 - PREFINISHED STEEL DOORS & FRAMES

3.2 INSTALLATION

- A. Install frames in accordance with ANSI A250.8.
- B. Install fire-rated frames in accordance with NFPA 80.
- C. Coordinate with masonry or gypsum board wall construction for anchor placement.
- D. Coordinate installation of frames with installation of hardware specified in Section 08 71 00.
- E. Redi-Frames should be installed plumb, rigid, in true alignment and braced properly until built in. Provide temporary wood spreader in middle while walls are being constructed. Anchor to floor at each jamb and to walls with anchors. Fill heads of flat head type attachments with body putty and grind smooth.
- F. Steel Adjusta-Frame Installation: Install steel frames. Installation shall be plumb, straight and true, rigidly secured in place, and properly braced. Comply with Manufacturer's installation instructions and ANSI/DHI A115-IG installation guide.
 - 1. Secure anchorages and connections to adjacent construction.
 - 2. Install hardware in accordance with manufacturers' templates and instructions.
 - 3. Finish exposed field welds to present a smooth uniform surface. Touch up with a rust inhibitive primer.
 - 4. Touch up exposed surfaces scratched or marred during shipment, installation or handling with a rust inhibitive primer.
- G. Installation Reference Standard(s): Install frames in accordance with requirements of applicable reference standards.
 - 1. Comply with Steel Door Institute (SDI) installation and maintenance standards.
 - 2. Comply with NFPA80 installation standards.
 - 3. Regulatory Requirements: Install fire labeled steel door and frame product in accordance with NFPA80, current edition, unless specified otherwise.

3.3 ERECTION TOLERANCES

- A. Section 01 40 00 – Quality Requirements: Tolerances.
- B. Maximum Diagonal Distortion: 1/16 inch measured with straight edges, crossed corner to corner.

3.4 CLEANING

- A. Remove temporary coverings and protection of adjacent work areas. Repair or replace damaged installed products. Clean installed products in accordance with manufacturer's instructions prior to Owner's acceptance. Remove construction debris from project site and legally dispose of debris.

3.5 PROTECTION

- A. Protect installed product and finish surfaces from damage during construction.
 - 1. Repair or replace damaged or defective frames.
 - 2. Touch up damaged areas of factory-applied finishes with aerosol spray cans of same paint as used in factory.

3.6 SCHEDULE

- A. Refer to Door and Frame Schedule as indicated in drawings.

1. PART 1 GENERAL

1.1 SUMMARY

A. This section covers the furnishing of all labor; equipment and materials to complete the steel doors and decorative glass patio doors, as shown on the drawings and as specified herein.

B. Related Sections:

1. Section 06 20 00 – Finish Carpentry: Installation of doors and frames.
2. Section 08 11 00 – Prefinished Steel Door Frames.
3. Section 08 71 00 – Door Hardware: Hardware, silencers, and weatherstripping.
4. Section 08 80 00 – Glazing.

1.2 REFERENCES

A. American National Standards Institute:

1. ANSI/DHI A115.IG Installation Guide for Doors and Hardware.
2. ANSI/SDI Standard A224.1 Test Procedure and Test Criteria for Prime Painted Steel Surfaces for Steel Doors and Frames.
3. ANSI A250.8 – Recommended Specifications for Standard Steel Doors and Frames.

B. ASTM International:

1. ASTM A366 Standard Specification for Commercial Steel (CS) Sheet, Carbon (0.15 Maximum percent) Cold-Rolled.
2. ASTM A653/A653M – Standard Specification for Steel Sheet, Zinc-Coated (Galvanized) or Zinc-Iron Alloy-Coated (Galvannealed) by the Hot-Dip process.
3. ASTM A924 Standard Specification for General Requirements for steel sheet, metallic Coated by the Hot-Dip process.
4. ASTM D610 Standard Test Method for Evaluating Degree of Rust on Painted Steel Surfaces.
5. ASTM D714 Standard Test Method for Evaluating Degree of Blistering of Paints.
6. ASTM D1622 Standard Test Method for Apparent Density of Rigid Cellular Plastics.
7. ASATM D1654 Standard Test Method for Evaluation of Painted or Coated Specimens Subjected to Corrosive Environments.

C. National Fire Protection Association:

1. NFPA 80 – Standard for Fire Doors, Fire Windows.
2. NFPA 252 – Standard Methods of Fire Tests of Door Assemblies.

D. Underwriters Laboratories, Inc.:

1. UL 10B – Fire Tests of Door Assemblies.
2. UL 10C – Positive Pressure Fire Tests of Door Assemblies.
3. UL 1784 – Air Leakage Tests of Door Assemblies.

1.3 SUBMITTALS

A. Section 01 33 00 – Submittal Procedures: Submittal procedures.

B. Shop Drawings: Indicate door type, steel, core, material thickness, reinforcement, anchor types and spacing, location of cutouts for hardware, and finish. Include schedule identifying each unit with door marks or numbers referencing schedules and drawings.

C. Product Data: Submit door configuration and finishes.

D. Samples: Submit selection and verification samples for finishes, colors, and textures. Coordinate with Division 9 Painting Section for paint finishes.

1.4 QUALITY ASSURANCE

A. Conform to requirements of ANSI A250.8.

B. Fire Rated Frame Construction: Conform to NFPA 252.

C. Smoke and Draft Control Door Frames: Tested in accordance with UL 1784.

1. Air Leakage: Maximum 3.0 cfm/sf of door opening with 0.10 inch water gage pressure differential.

D. Attach label from agency approved by authority having jurisdiction to identify each fire rated door and frame.

1. Attach smoke label to smoke and draft control doors and frames.

1.5 QUALIFICATIONS

A. Manufacturer: Company specializing in manufacturing products specified in this section with minimum three years documented experience.

081300 - STANDARD STEEL DOORS

1.6 DELIVERY, STORAGE, AND HANDLING

- A. Section 01 60 00 – Product Requirements: Product storage and handling requirements.
- B. Protect doors with resilient packaging and crate doors for delivery to site.
- C. Accept doors on site in manufacturer's original, unopened, undamaged containers with identification labels intact. Inspect for damage.
 - 1. Handle and store products according to manufacturer's recommendations published in technical materials. Leave product wrapped or otherwise protected and under clean dry storage conditions until required.
- D. At site, uncrate doors and store in vertical position. Store under cover and off ground in manner that will prevent rust and damage. Break seal on-site to permit ventilation.

1.7 COORDINATION

- A. Section 01 31 16 – Coordination & Meetings: Coordination and project conditions.
- B. Coordinate Work with frame opening construction and hardware installation.
- C. Sequence installation to accommodate required door hardware.

1.8 WARRANTY

- A. Five-year limited manufacturer's warranty.
 - 1. Submit for owner's acceptance, manufacturer's standard warranty documented by an authorized company official.

PART 2 PRODUCTS

2.1 HOLLOW METAL DOORS AND FRAMES

- A. Manufacturers:
 - 1. Therma-Tru Doors.
 - 2. Contact: 1750 Indian Wood Circle, Maumee, OH 43537; Telephone: (419) 891-7400; Fax: (419) 482-9100; Web: www.thermatru.com.
 - 3. Substitutions: Section 01 60 00 – Product Requirements.
- B. Product Description: Standard shop fabricated steel entry doors, fire rated and non-rated types.
 - 1. Lighted Models TS 206 & Embossed TS 210:
 - a. Style: Traditions; Embossed: 24 ga.
 - 2. Label doors and frames according to UL fire-rating as scheduled on drawings.
- C. Doors:
 - 1. Impact rated steel entry door, with solid wood lock block for secure mounting of hardware.
 - 2. Exterior doors to be insulated.
 - 3. Cold rolled steel: comply with ASTM A366 cold rolled carbon sheet steel.
 - 4. Galvanized steel: comply with ASTM A924 general requirements for steel metallic coated by hot dip process.
- D. Frames:
 - 1. Wood Frames by therma- tru doors – **aluminum clad**.
 - 2. Aluminum brick mold applied to exterior
- E. Casing
 - 1. Provide Oak colonial casing at the interior of all steel doors prefinished to match casework.

2.2 ACCESSORIES

- A. Bituminous Coating: Non-asbestos fibered asphalt emulsion.
- B. Primer: ANSI A250.10 rust inhibitive type.
- C. Painted finish material: Comply with ANSI A250.3 test procedures and acceptance criteria for factory applied finish for steel doors.
 - 1. Door color paint material: Provide manufacturer's standard finish and color.
- D. Silencers: Specified in Section 08 71 00.
- E. Weatherstripping: Specified in 08 71 00.

081300 - STANDARD STEEL DOORS

2.3 FABRICATION

A. Coordinate machined hinge jambs for door frames with hardware section 08 71 00.

1. Doors shall have four inch high hinge preps machined, reinforced as follows:
2. 12-24 TR Series-10 gage plates tapped to receive 10-24 screws for secure anchoring of hinges.
3. Steel face sheets shall be 24 Therma-Tru galvanized tension leveled steel for superior flatness & enhanced corrosion resistance.
4. Insulated - Doors shall be foamed in place, stiffened & structurally reinforced with environmentally friendly polyurethane and bonded to inside skins with minimal voids.
5. Rugged Construction - The door edges shall be mechanically overlapped and reinforced the full height on both sides of door and adhered with foamed in place polyurethane. The door shall be stiffened with integrally formed top and bottom rails securely welded at top and bottom of door with two welds each.
6. Advanced Lock Reinforcing – Latching and deadlocking hardware is supported with advanced injection molded composite lock reinforcement with superior screw holding power. Advanced door avoids the problem of ‘telegraphing’ of the lock reinforcement typical with wood blocks. Design also allows for uniform foam flow for a flatter door face at lock area.
7. Lock Machining – Lock preparations include 2-1/8” face bores at both 2-3/4” & 2-3/8” backsets. Edge preps for cylindrical preps shall feature 2-1/4” x 1-1/8”. Deadlock edge prep located at 5-1/2” centers to latching edge prep. Deadlock cross bore optional.
8. Surface Mounted Hardware – Exit hardware and closure reinforcements shall be fabricated from 16 gage steel x 5” x 20” securely attached to both skins of the door.
9. Screw applied bottom sweep for enhanced water and air infiltration resistance.

B. Attach fire rated label to each fire rated door.

2.4 SHOP FINISHING

A. Factory Finish: Paint Finish – Doors shall receive a factory prime finish for added rust inhibition. Primed surface shall be suitable for maximum adhesion of finish top coat.

PART 3 EXECUTION

3.1 EXAMINATION

A. Section 01 31 16 – Product Requirements: Coordination and project conditions.

B. Verify opening sizes and tolerances are acceptable and that door frame openings are installed plumb, true and level before beginning installation process. Select fasteners of adequate type, number and quality to perform the intended functions.

3.2 INSTALLATION

A. Install doors in accordance with ANSI A250.8.

B. Comply with Door and Hardware Institute (DHI) installation standards and with Steel Door Institute (SDI) installation and maintenance standards.

C. Regulatory Requirements: Install fire labeled steel door product in accordance with NFPA 80, current edition, unless specified otherwise.

D. Coordinate installation of hardware specified in Section 08 71 00.

1. Install hardware in accordance with manufacturer’s templates and instructions.

3.3 ERECTION TOLERANCES

A. Section 01 40 00 – Quality Requirements: Tolerances.

B. Maximum Diagonal Distortion: 1/16 inch measured with straight edges, crossed corner to corner.

3.4 ADJUSTING

A. Adjusting: Adjust hinge sets, locksets and other hardware. Lubricate using a suitable lubricant compatible with door and frame coatings.

3.5 CLEANING

A. Cleaning: Remove temporary coverings and protection of adjacent work areas. Repair or replace products that have been installed and are damaged. Clean installed products in accordance with manufacturer’s instructions prior to Owner’s acceptance. Remove construction debris from project site and legally dispose of debris.

3.6 PROTECTION

A. Protection: Protect installed product and finish surfaces from damage during construction.

3.7 SCHEDULE

A. Refer to Door Schedule as indicated in drawings.

SECTION 08 14 00 – COMPOSITE WOOD DOORS

1. PART 1 GENERAL

1.1 SUMMARY

A. Section includes composite wood doors; fire rated and non-rated.

B. Related Sections:

1. Section 08 11 00 – Prefinished Steel Door Frames.
2. Section 08 71 00 – Door Hardware.
3. Section 09 90 00 – Painting.

1.2 REFERENCES

A. American National Standards Institute:

1. ANSI A135.4 – Basic Hardboard.

B. ASTM International:

1. ASTM D-1037 – Standard Method for Evaluating the Properties of Wood-Based Fiber and Particle Board Panel Materials.
2. ASTM E 152-81a – Standard Methods of Fire Tests of Door Assemblies.

C. Architectural Woodwork Institute:

1. AWI – Quality Standards Illustrated.
2. AWI Section 1300 – Architectural Flush Doors.

D. Hardwood Plywood and Veneer Association:

1. HPVA HP-1 – American National Standard for Hardwood and Decorative Plywood.

E. Intertek Testing Services (Warnock Hersey Listed):

1. WH – Certification Listings.

F. National Electrical Manufacturers Association:

1. NEMA LD 3 – High Pressure Decorative Laminates.

G. National Fire Protection Association:

1. NFPA 80 Standard for Fire Doors, Fire Windows.
2. NFPA 252 – Standard Methods of Fire Tests of Door Assemblies.

H. Underwriters Laboratories, Inc.:

1. UL – Building Materials Directory.
2. UL 10B – Fire Tests of Door Assemblies.
3. UL 10C – Positive Pressure Fire Tests of Door Assemblies.
4. UL 1784 – Air Leakage Tests of Door Assemblies.

I. Uniform Building Code:

1. UBC Standard 7-2 – Fire Tests of Door Assemblies.

J. Window and Door Manufacturers Association:

1. WDMA Finish System TR-6, transparent – Catalyzed Polyurethane.
2. WDMA I.S.I-A – Architectural Wood Flush Doors.

1.3 SUBMITTALS

A. Section 01 33 00 – Submittal Procedures: Submittal procedures.

B. Shop Drawings: Illustrate door opening criteria, elevations, sizes, types, swings, undercuts required, special beveling, special blocking for hardware, factory machining criteria, factory finishing criteria.

C. Product Data: Submit information on door core materials and construction, and on veneer species, type and characteristics.

D. Samples:

1. Submit two samples of door construction, 8x8 inch in size cut from top corner of door.
2. Submit two samples of door veneer cut and grain pattern, 12x12 inch in size cut horizontally across the entire width of the door, showing veneer slices, match pattern and joint.
3. Submit two samples of door veneer, 12x12 inch in size illustrating wood grain, stain color, and sheen.

E. Manufacturer's Installation Instructions: Submit special installation instructions.

081400 - INTERIOR WOOD DOORS

1.4 QUALITY ASSURANCE

- A. Perform Work in accordance with AWI Quality Standard Section 1300, Custom Grade.
- B. Tolerances for Warp, Telegraphing, Squareness, and Prefitting Dimensions: WDMA I.S.1-A.
- C. Finish doors in accordance with AWI Quality Standard Section 1500, grades identified in section.
- D. Fire Rated Door Construction: Conform to NFPA 252.
- E. Fire Rated Door and Panel Construction: Conform to one of the following:
 - 1. NFPA 252; with neutral pressure level at 50 inches maximum above sill at 5 minutes into test.
 - 2. UL 10C.
- F. Fire Rated Door Construction: Conform to UBC Standard 7-2.
- G. Fire Rated Stair Doors: Rate of rise of 450 degrees F across door thickness.
- H. Installed Fire Rated Door Assembly: conform to NFPA 80 for fire rated class as indicated on Drawings.
- I. Smoke and Draft Control Doors: Tested in accordance with UL 1784.
 - 1. Air Leakage: Maximum 3.0 cfm/sf of door opening with 0.10-inch water gage pressure differential.
- J. Identifying Label: Each door shall bear identifying label indicating:
 - 1. Door manufacturer.
 - 2. Order number.
 - 3. Door number.
 - 4. Fire rating, if applicable.
- K. Attach labeled by Intertek/Warnock Hersey, to identify each fire rated door.
 - 1. Indicate temperature rise rating for stair doors.
 - 2. Attach smoke label to smoke and draft control doors.
- L. Environmental Responsibility: Provide doors manufactured with the following environmentally responsible core materials:
 - 1. Particleboard Core: Scientific Certification Systems (SCS) certified.

1.5 QUALIFICATIONS

- A. Manufacturer: Company specializing in manufacturing products specified in this section with minimum three years documented experience.

1.6 DELIVERY, STORAGE, AND HANDLING

- A. Section 01 60 00 – Product Requirements: Product storage and handling requirements.
- B. Accept doors on site in manufacturer's packaging. Inspect for damage.
- C. Protect doors with resilient packaging and store in accordance with manufacturer's instructions. Do not store in damp or wet areas; or in areas where sunlight might bleach veneer. Seal top and bottom edges when stored more than one week.
 - 1. Break seal on site to permit ventilation.
 - 2. Store doors flat on level surface in a well ventilated dry building.
 - 3. Do not store doors on edge or directly on concrete. Protect from dirt, water and abuse.
 - 4. Keep doors completely covered. Use covering, which allows air circulation and does not permit light to penetrate.
 - 5. Store doors between 50 and 90 degrees F (10 and 32 degrees C) and 30 to 69 percent relative humidity.
- D. Handling:
 - 1. Handle doors in accordance with manufacturer's instructions.
 - 2. Protect doors and finish during handling and installation to prevent damage.
 - 3. Handle doors with clean hands or clean gloves.
 - 4. Lift and carry doors. Do not drag doors across other doors or surfaces.
 - 5. Each door shall be marked with the opening number / and or type.

1.7 COORDINATION

- A. Section 01 31 16 – Coordination & Meetings: Coordination and project conditions.
- B. Coordinate Work with door opening construction, door frame and door hardware installation.

1.8 WARRANTY

- A. Section 01 70 00 – Contract Closeout Requirements: Product warranties and product bonds.
- B. Include coverage for delamination of veneer, warping beyond specified installation tolerances, defective materials, and telegraphing core construction.

PART 2 PRODUCTS

2.1 HOLLOW CORE RAISED PANEL DOORS

A. Manufacturers:

1. Marshfield Door Systems.

B. Other Acceptable Manufacturers:

1. VT Industries.
2. Mohawk.
3. Substitutions: Section 01 60 00 – Product Requirements.

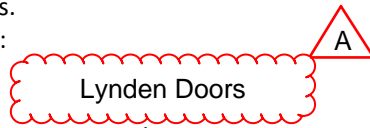

2.2 CONSTRUCTION

A. Non-Rated hollow Core:

1. Panel Size: See Schedule.
2. Panel Thickness: 1 3/8 inch.
3. Panel type: CB601 6 panel.
4. Finish: Pre-finished KD Colonial Casing– color by Architect.
5. Profiles and dimensions shall be manufacturer's standard unless otherwise noted in the drawings and elevations.

2.3 FABRICATION

- A. Fabricate doors in accordance with AWI Quality Standards requirements.
- B. Furnish lock blocks at lock edge and top of door for closer for hardware reinforcement.
- C. Factory fit and machine doors at factory for frame opening dimensions identified on shop drawings.
- D. Provide accurate measurements of hardware locations in wood or metal frames before proceeding with factory machining.
- E. Factory machine doors for finish hardware in accordance with hardware requirements and dimensions, door frame shop drawings and with hardware templates to ensure proper fit of doors and hardware. Do not machine for surface hardware. Furnish solid blocking for through bolted hardware.
- F. Tolerances: Comply with WDMA tolerance requirements for fitting.
- G. Fit and Bevel Doors 1/8" in 2 inches. Ensure proper gaps are maintained on fire doors to comply with NFPA 80 requirements.

2.4 SHOP FINISHING

- A. Composite wood doors shall be factory prefinished.

PART 3 EXECUTION

3.1 EXAMINATION

- A. Section 01 31 16 – Coordination & Meeting: Coordination and project conditions.
- B. Verify opening sizes and tolerances are acceptable.
- C. Do not install doors in frame openings that are not plumb or are out-of-tolerance for size or alignment.
- D. Beginning of work will indicate acceptance of existing conditions by installer.

3.2 INSTALLATION

- A. Install doors in accordance with AWI Quality Standards requirements and with manufacturer's recommendations to comply with WDMA IS 1A 04 and NFPA 80.
 1. Installation by Section 06 20 00 – Finish Carpentry.
 2. Installer to assure compliance with the requirements of the manufacturer's door warranty provisions.
- B. After sizing doors, fit for hardware as scheduled.
- C. Hang doors to be free of binding with hardware functioning properly.

3.3 INSTALLATION TOLERANCES

- A. Section 01 40 00 – Quality Requirements: Tolerances.
- B. Conform to AWI requirements for fit and clearance tolerances.
- C. Maximum Diagonal Distortion (Warp): 1/8 inch measured with straight edge or taut string, corner to corner, over imaginary 36 x 84 inches surface area.
- D. Maximum Vertical Distortion (Bow): 1/8 inch measured with straight edge or taut string, top to bottom, over imaginary 36 x 84 inches surface area.
- E. Maximum Width Distortion (Cup): 1/8 inch measured with straight edge or taut string, edge to edge, over imaginary 36 x 84 inches surface area.

3.4 ADJUSTING

- A. Section 01 70 00 – Contract Closeout Requirements: Testing, adjusting, and balancing.
- B. Adjust door for smooth and balanced door movement and leave in proper operating condition.
- C. Adjust closer for full closure.
- D. Refinish or replace doors damaged during installation.

PART 1 GENERAL

1.1 WORK INCLUDED

- A. Rated and Non-rated access doors and frames as indicated or required.
- B. Incidental access doors required to gain access to work or equipment specified under division 21 - 28 and not indicated on plan are furnished by Mechanical or Electrical as applicable and installed by this section.

1.2 RELATED WORK

- A. Section 09 25 00 - Gypsum Board System.
- B. Section 09 90 00 - Painting: Field paint finish.

PART 2 PRODUCTS

2.1 ACCESS DOORS

- A. J. L. Industries
- B. In Non-Rated Gypsum Board: Model WB, screw driver slot, and quarter turn cam lock; supply primed with alkyd primer; finish by 09 90 00.
- C. Rated, in gypsum board; Model FD, turn ring and quarter turn cam lock; supplied primed finish by 09 90 00.
- D. Substitutions: Under provisions of Section 01 60 00.

PART 3 EXECUTION

3.1 INSPECTION

- A. Verify rough openings for door and frame are correctly sized and located.
- B. Beginning of installation means acceptance of existing conditions.

3.2 INSTALLATION

- A. Doors to include all required installation assemblies, parts and hardware for a complete installation.
- B. Install frame plumb and level in ceiling openings.
- C. Position to provide convenient access to concealed work requiring access.
- D. Secure rigidly in place in accordance with manufacturer's instructions.

SECTION 08 36 00 - POWER OPERATED SECTIONAL OVERHEAD DOORS

1. PART 1: GENERAL

1.1 SECTION INCLUDES

- A. Power Operated overhead sectional doors.
- B. Steel, insulated, thermally broken panels of ribbed design.
- C. Operating hardware and supports.

1.2 RELATED SECTIONS

- A. Section 07 90 00 - Joint Sealers: Perimeter sealant and backup materials.
- B. Division 16 - Electrical.

1.3 REFERENCES

- A. ANSI A216.1 - Sectional Overhead Type Door (NAGDM 102).
- B. ASTM A446 - Steel Sheet, Zinc-Coated (Galvanized) by the Hot-Dip Process, Structural (Physical) Quality.
- C. ASTM A526 - Steel Sheet, Zinc-Coated (Galvanized) by the Hot-Dip Process, Commercial Quality.
- D. ASTM E330 - Structural Performance of Exterior Windows, Curtain Walls, and Doors by Uniform Static Air Pressure Difference.

1.4 SYSTEM DESCRIPTION

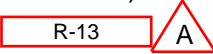
- A. Raised Panel, 26 ga. Prefinished, insulated (R-~~X~~min), steel, two-sided door. 
- B. Vertical Lift, high headroom, standard headroom, and low headroom track appropriate for location indicated on drawings with appropriate hardware. Fit track as close to wall and ceiling construction as hardware permits.
- C. Operation: Power operation with manufacturers recommended (select) operator, interior single button push button station, (verify locations with owner), photo electronic safety and reversing edges, to comply with all applicable safety requirements.
- D. Design and size components to withstand dead and live loads caused by pressure and suction of wind acting normal to plane of wall as measured in accordance with ANSI/ASTM E330.

Loop in concrete to exit and operators to enter 

1.5 SUBMITTALS

- A. Product Data: Provide component construction, anchorage method and hardware.
- B. Manufacturer's Installation Instructions: Indicate special procedures and perimeter conditions requiring special attention.

1.6 OPERATIONS AND MAINTENANCE DATA

- A. Submit under provisions of Section 01 77 00.

1.7 QUALITY ASSURANCE

- A. Perform Work in accordance with ANSI A216.1, Application Type Commercial.

1.8 WARRANTY

- A. Provide manufacturers standard warranties.

PART 2: PRODUCTS

2.1 MANUFACTURERS

- A. Overhead Door Company
- B. Raynor
- C. Midland Garage Door Manufacturing Company
- D. RSIC-GDS Motor Kit Parts
- E. Substitutions under provisions of Section 01 60 00.

3inch wide commercial grade track system

2.2 DOOR COMPONENTS

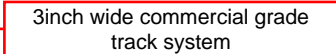
- A. Track: 17 gauge thick; 2 ~~inch~~ wide rolled steel track. 
- B. Hinge and Roller Assemblies: Heavy duty hinges and adjustable roller holders of galvanized steel.
- C. Lift Mechanism: Torsion spring on cross head shaft, with braided steel lift cables. Operation: A maximum lift of 25 lbs. force.
- D. Sill Weatherstripping: Resilient vinyl strip, one piece; fitted to bottom of door panel, full length contact.
- E. Jamb Weatherstripping: Roll formed steel section full height of jamb, fitted with resilient weatherstripping, placed in moderate contact with door panels.
- F. Lock: Setup for overhead door opener.
- G. RSIC-GDS Motor Kit Parts List:
 - 2 ea RSIC-GDS Motor Isolators 2 ea 3/4" bolts
 - 4 ea 3-1/2" coarse thread screws 2 ea nyloc nuts
 - 4 ea RSIC 1-1/2" Fender washers 4 ea 3/4" washers

2.3 FINISHES

- A. Exterior Surfaces: Color selection by Owner.
- B. Interior Surfaces: White.

PART 3: EXECUTION

3.1 EXAMINATION

- A. Verify that wall openings are ready to receive work and opening dimensions and tolerances are within specified limits.
- B. Beginning of installation means acceptance of existing surfaces.

3.2 PREPARATION

- A. Prepare opening to permit correct installation of door unit to perimeter air and vapor barrier seal.

3.3 INSTALLATION

- A. Install door unit assembly in accordance with manufacturer's instructions.
- B. Anchor assembly to wall construction and building framing without distortion or stress.
- C. Securely brace door tracks suspended from structure. Secure tracks to structural members
- A. Perform Work in accordance with ANSI A216.1, Application Type, Commercial.
- D. Fit and align door assembly including hardware, level and plumb, to provide smooth operation.
- E. Coordinate installation of sealants and backing materials at frame perimeter as specified in Section 07 90 00.
- F. Install perimeter trim and closures.
- G. Installer to provide & install all low voltage wiring and components.

3.4 TOLERANCES

- A. Maintain dimensional tolerances and alignment with adjacent work.
- B. Maximum Variation from Plumb: 1/16 inch.
- C. Maximum Variation from Level: 1/16 inch.
- D. Longitudinal or Diagonal Warp: Plus or minus 1/8 inch from 10 ft straight edge.

3.5 MANUFACTURER'S FIELD SERVICES

- A. Ensure the operation and adjustments to door assembly for smooth operation.

3.6 ADJUSTING

- A. Adjust work under provisions of Section 01 77 00.
- B. Adjust door assembly to smooth operation.

3.7 CLEANING

- A. Clean work under provisions of 01 77 00.
- B. Clean doors, frames.
- C. Remove labels and visible markings.

3.8 PROTECTION OF FINISHED WORK

- A. Protect finished Work under provisions of Section 01 50 00.
- B. Do not permit construction traffic through overhead door openings after adjustment and cleaning.

3.9 SCHEDULE

- A. As Indicated on plan.

PART 1 GENERAL

1.1 SECTION INCLUDES

- A. Aluminum-framed storefront, with vision glass.
- B. Aluminum doors and frames.
- C. Weatherstripping.

1.2 RELATED REQUIREMENTS

- A. Section 08 7100 - Door Hardware: Hardware items other than specified in this section.
- B. Section 08 8000 - Glazing: Glass and glazing accessories.

1.3 REFERENCE STANDARDS

- A. AAMA CW-10 - Care and Handling of Architectural Aluminum From Shop to Site; current publication.
- B. AAMA 501.2 - Quality Assurance and Diagnostic Water Leakage Field Check of Installed Storefronts, Curtain Walls, and Sloped Glazing Systems; current publication.
- C. AAMA 609 & 610 - Cleaning and Maintenance Guide for Architecturally Finished Aluminum (Combined Document).
- D. AAMA 611 - Voluntary Specification for Anodized Architectural Aluminum.
- E. ASTM A36/A36M - Standard Specification for Carbon Structural Steel.
- F. ASTM A123/A123M - Standard Specification for Zinc (Hot-Dip Galvanized) Coatings on Iron and Steel Products.
- G. ASTM B221 - Standard Specification for Aluminum and Aluminum-Alloy Extruded Bars, Rods, Wire, Profiles, and Tubes.
- H. ASTM B221M - Standard Specification for Aluminum and Aluminum-Alloy Extruded Bars, Rods, Wire, Profiles, and Tubes [Metric].
- I. ASTM E283 - Standard Test Method for Determining the Rate of Air Leakage Through Exterior Windows, Curtain Walls, and Doors Under Specified Pressure Differences Across the Specimen, current.
- J. ASTM E330/E330M - Standard Test Method for Structural Performance of Exterior Windows, Doors, Skylights and Curtain Walls by Uniform Static Air Pressure Difference.
- K. ASTM E331 - Standard Test Method for Water Penetration of Exterior Windows, Skylights, Doors, and Curtain Walls by Uniform Static Air Pressure Difference.
- L. SSPC-Paint 20 - Zinc-Rich Primers (Type I, "Inorganic," and Type II, "Organic").

1.4 ADMINISTRATIVE REQUIREMENTS

- A. Coordinate with installation of other components that comprise the exterior enclosure.
- B. Preinstallation Meeting: Conduct a preinstallation meeting one week before starting work of this section; require attendance by all affected installers.

1.5 SUBMITTALS

- A. See Section 01 3000 - Administrative Requirements, for submittal procedures.
- B. Product Data: Provide component dimensions, describe components within assembly, anchorage and fasteners, glass and infill, internal drainage details.
- C. Shop Drawings: Indicate system dimensions, framed opening requirements and tolerances, affected related Work, expansion and contraction joint location and details, and field welding required.
- D. Design Data: Provide framing member structural and physical characteristics, engineering calculations, and dimensional limitations.
- E. Warranty: Submit manufacturer warranty and ensure forms have been completed in Owner's name and registered with manufacturer.

1.6 QUALITY ASSURANCE

- A. Designer Qualifications: Design structural support framing components under direct supervision of a Professional Structural Engineer experienced in design of this Work and licensed in the State in which the Project is located.
- B. Manufacturer Qualifications: Company specializing in performing work of type specified and with at least three years of experience.
- C. Installer Qualifications: Company specializing in performing work of type specified and with at least three years of experience.

1.7 DELIVERY, STORAGE, AND HANDLING

- A. Handle products of this section in accordance with AAMA CW-10.
- B. Protect finished aluminum surfaces with wrapping. Do not use adhesive papers or sprayed coatings that bond to aluminum when exposed to sunlight or weather.

1.8 FIELD CONDITIONS

- A. Do not install sealants when ambient temperature is less than 40 degrees F (5 degrees C). Maintain this minimum temperature during and 48 hours after installation.

1.09 WARRANTY

- A. See Section 01 7800 - Closeout Submittals, for additional warranty requirements.
- B. Correct defective Work within a five-year period after Date of Substantial Completion.
- C. Provide five-year manufacturer warranty against failure of glass seal on insulating glass units, including interpane dusting or misting. Include provision for replacement of failed units; fading, chalking, or flaking.

PART 2 PRODUCTS

2.1 BASIS OF DESIGN -- FRAMING FOR INSULATING GLAZING

A. Front-Set Style, Thermally-Broken:

1. Basis of Design: Kawneer; Trifab VG 451T.
2. Basis of Design: Tubelite; 14000 I/O Series.
3. Basis of Design: EFCO Corporation; Series 433, Thermal Triple-Set Storefront Framing: www.efcocorp.com/sle.
4. Basis of Design: CMI Architectural; 450TB FS.
5. Basis of Design: Manko; 2450FS Series.

B. Substitutions: See Section 01 6000 - Product Requirements.

1. For any product not identified as "Basis of Design", submit information as specified for substitutions.

2.2 BASIS OF DESIGN -- SWINGING DOORS

A. Medium Stile, Insulating Glazing, Not Thermally-Broken:

1. Basis of Design: Kawneer; 350 Medium Stile Door.
2. Basis of Design: Tubelite; Medium Stile Doors
3. Basis of Design: EFCO Corporation; Series D300 Medium Stile: www.efcocorp.com/sle.
4. Basis of Design: CMI Architectural; 351 Medium Stile Door.
5. Basis of Design: Manko; 135 Series Medium Stile Door.

B. Substitutions: See Section 01 6000 - Product Requirements.

1. For any product not identified as "Basis of Design", submit information as specified for substitutions.

2.3 STOREFRONT

A. Aluminum-Framed Storefront: Factory fabricated, factory finished aluminum framing members with infill, and related flashings, anchorage and attachment devices. <ALUM STOR-1>

1. Glazing Rabbet: For 1 inch (25 mm) insulating glazing.
2. Finish: Class I color anodized.
 - a. Factory finish all surfaces that will be exposed in completed assemblies.
3. Finish Color: Black.
4. Fabrication: Joints and corners flush, hairline, and weatherproof, accurately fitted and secured; prepared to receive anchors and hardware; fasteners and attachments concealed from view; reinforced as required for imposed loads.
5. Construction: Eliminate noises caused by wind and thermal movement, prevent vibration harmonics, and prevent "stack effect" in internal spaces.
6. System Internal Drainage: Drain to the exterior by means of a weep drainage network any water entering joints, condensation occurring in glazing channel, and migrating moisture occurring within system.
7. Expansion/Contraction: Provide for expansion and contraction within system components caused by cycling temperature range of 170 degrees F (95 degrees C) over a 12 hour period without causing detrimental effect to system components, anchorages, and other building elements.
8. Movement: Allow for movement between storefront and adjacent construction, without damage to components or deterioration of seals.
9. Perimeter Clearance: Minimize space between framing members and adjacent construction while allowing expected movement.

B. Performance Requirements:

1. Wind Loads: Design and size components to withstand the specified load requirements without damage or permanent set, when tested in accordance with ASTM E330/E330M, using loads 1.5 times the design wind loads and 10 second duration of maximum load.
 - a. Member Deflection: Limit member deflection to flexure limit of glass in any direction; full recovery of glazing materials.
2. Water Penetration Resistance: No uncontrolled water on interior face, when tested in accordance with ASTM E331 at pressure differential of 8 psf (390 Pa).
3. Air Leakage: Maximum of 0.06 cu ft/min sq ft (0.3 L/sec sq m) of wall area, when tested in accordance with ASTM E283 at 6.27 psf (300 Pa) pressure differential across assembly.

2.4 COMPONENTS

A. Aluminum Framing Members: Tubular aluminum sections, thermally broken with interior section insulated from exterior, drainage holes and internal weep drainage system.

1. Framing members for interior applications need not be thermally broken (except at interior locations with insulated glass).
2. Glazing Stops: Flush.
3. Structurally Reinforced Members: Extruded aluminum with internal reinforcement of structural steel member.

084313 - ALUMINUM STOREFRONTS

- B. Glazing: As specified in Section 08 8000.
- C. Swing Doors: Glazed aluminum.
 - 1. Thickness: 1-3/4 inches (43 mm), minimum.
 - 2. Top Rail: 3-1/2 to 4 inches (84 to 101 mm) wide.
 - 3. Vertical Stiles: 3-1/2 to 4 inches (84 to 101 mm) wide.
 - 4. Bottom Rail: 10 inches (254 mm) wide.
 - 5. Glazing Stops: Square.
 - 6. Finish: Same as storefront.
- D. Sill Plate: Provide a subsill plate with integral front lip. Match finish of storefront system.

2.5 MATERIALS

- A. Extruded Aluminum: ASTM B221 (ASTM B221M).
- B. Structural Steel Sections: ASTM A36/A36M; galvanized in accordance with requirements of ASTM A123/A123M.
- C. Fasteners: Stainless steel.
- D. Exposed Flashings: Aluminum sheet, 20 gage, 0.032 inch (0.81 mm) minimum thickness; finish to match framing members.
- E. Glazing Gaskets: Type to suit application to achieve weather, moisture, and air infiltration requirements.
- F. Touch-Up Primer for Galvanized Steel Surfaces: SSPC-Paint 20, zinc rich.

2.6 FINISHES

- A. Class I Color Anodized Finish: AAMA 611 AA-M12C22A42 Integrally colored anodic coating not less than 0.7 mils (0.018 mm) thick.

2.7 HARDWARE

- A. Door Hardware: As specified in Section 08 7100 - Door Hardware.
- B. Weatherstripping: Wool pile, continuous and replaceable; provide on all doors.

PART 3 EXECUTION

3.1 EXAMINATION

- A. Verify dimensions, tolerances, and method of attachment with other work.
- B. Verify that wall openings and adjoining air and vapor seal materials are ready to receive work of this section.

3.2 INSTALLATION

- A. Install wall system in accordance with manufacturer's instructions.
- B. Attach to structure to permit sufficient adjustment to accommodate construction tolerances and other irregularities.
- C. Provide alignment attachments and shims to permanently fasten system to building structure.
- D. Align assembly plumb and level, free of warp or twist. Maintain assembly dimensional tolerances, aligning with adjacent work.
- E. Provide thermal isolation where components penetrate or disrupt building insulation.
- F. Install sill flashings. Turn up ends and edges; seal to adjacent work to form water tight dam.
- G. Where fasteners penetrate sill flashings, make watertight by seating and sealing fastener heads to sill flashing.
- H. Pack fibrous insulation in shim spaces at perimeter of assembly to maintain continuity of thermal barrier.
- I. Set thresholds in bed of sealant and secure.
- J. Install glass and infill panels in accordance with Section 08 8000, using glazing method required to achieve performance criteria.
- K. Touch-up minor damage to factory applied finish; replace components that cannot be satisfactorily repaired.

3.3 TOLERANCES

- A. Maximum Variation from Plumb: 0.06 inches every 3 ft (1.5 mm/m) non-cumulative or 1/16 inches per 10 ft (1.5 mm/3 m), whichever is less.
- B. Maximum Misalignment of Two Adjoining Members Abutting in Plane: 1/32 inch (0.8 mm).

3.4 FIELD QUALITY CONTROL

- A. See Section 01 4000 - Quality Requirements, for independent testing and inspection requirements. Inspection will monitor quality of installation and glazing.
- B. Test installed storefront for water leakage in accordance with AAMA 501.2 hose test.

3.5 ADJUSTING

- A. Adjust operating hardware for smooth operation.

3.06 CLEANING

- A. Remove protective material from pre-finished aluminum surfaces.
- B. Wash down surfaces with a solution of mild detergent in warm water, applied with soft, clean wiping cloths. Take care to remove dirt from corners. Wipe surfaces clean.
- C. Upon completion of installation, thoroughly clean aluminum surfaces in accordance with AAMA 609 & 610.

3.07 PROTECTION

- A. Protect installed products from damage until Date of Substantial Completion.

PART 1 GENERAL

1.1 SECTION INCLUDES

- A. Vinyl-framed, factory-glazed windows.
- B. Operating hardware.

1.2 RELATED REQUIREMENTS

- A. Section 07 9200 - Joint Sealants:
Sealing joints between frames and adjacent construction.

1.3 REFERENCE STANDARDS

- A. AAMA/WDMA/CSA 101/I.S.2/A440 - North American Fenestration Standard/Specification for windows, doors, and skylights; 2011.
- B. AAMA 701/702 - Combined Voluntary Specifications for Pile Weatherstrip and Replaceable Fenestration Weatherseals; 2011.
- C. ASTM E2112 - Standard Practice for Installation of Exterior Windows, Doors and Skylights; 2007.

1.4 ADMINISTRATIVE REQUIREMENTS

- A. Preinstallation Meeting: Convene one week before starting work of this section.
 - 1. Manufacturer's representative shall be required to attend meeting.

1.5 SUBMITTALS

- A. See Section 01 3000 - Administrative Requirements, for submittal procedures.
- B. Product Data: Provide component dimensions, anchors, fasteners, glass, and internal drainage.
- C. Shop Drawings: Indicate opening dimensions, framed opening tolerances, affected related work, and installation requirements.
- D. Manufacturer's Certificate: Certify that products of this section meet or exceed specified requirements.
- E. Grade Substantiation: Prior to submitting shop drawings or starting fabrication, submit one of the following showing compliance with specified grade:
 - 1. Evidence of AAMA Certification.
 - 2. Evidence of WDMA Certification.
 - 3. Evidence of CSA Certification.
 - 4. Test report(s) by independent testing agency itemizing compliance and acceptable to authorities having jurisdiction.
- F. Warranty: Submit manufacturer warranty and ensure that forms have been completed in Owner's name and registered with manufacturer.

1.6 QUALITY ASSURANCE

- A. Manufacturer Qualifications: Company specializing in manufacturing products specified in this section, with not less than three years of documented experience.
- B. Installer Qualifications: Company specializing in performing of type specified and with at least three years documented experience.

1.7 DELIVERY, STORAGE, AND HANDLING

- A. Protect finished surfaces with wrapping. Do not use adhesive papers or sprayed coatings that bond when exposed to sunlight or weather.
- B. Jig, brace, and box the window frame assemblies for transport to minimize flexing of members or joints.

1.8 FIELD CONDITIONS

- A. Do not install sealants when ambient temperature is less than 40 degrees F (5 degrees C).
- B. Maintain this minimum temperature during and after installation of sealants.

1.9 MOCKUP

- A. Provide one window installed for approval. Mockup shall include the window and associated flashing and air barriers. Remaining windows cannot be installed until mockup has been reviewed and approved by Owner, Architect, window manufacturer and air barrier manufacturer.

1.10 WARRANTY

- A. See Section 01 7800 - Closeout Submittals, for additional warranty requirements.
- B. Correct defective Work within a ten year period after Date of Substantial Completion.
- C. Provide ten year manufacturer warranty for insulated glass units from seal failure, interpane dusting or misting, and replacement of same. Include coverage for degradation of color finish.



2. Exterior Windows and Doors Per MHFA requirements

- (a) All new windows and doors must be ENERGY STAR-qualified. Confirm that the most updated ENERGY STAR requirements are met at the time of purchase. Confirm that the applicable Minnesota region is designated for ENERGY STAR requirements.
- (b) Special windows, such as those required for high-rise buildings, that are unable to meet ENERGY STAR qualifications are acceptable if they include double pane, low-e glass and thermally broken frames.
- (c) All windows and windows within doors must be furnished with window coverings for privacy and control of heat/solar shading.
- (d) All operable windows and operable windows within doors must have insect screens.
- (e) The sill of all windows must be solid wood, stone, man-made solid surface material, or other material approved by Minnesota Housing.
- (f) When possible, design the building garage overhead openings with two doors in lieu of one large door. This allows less energy to escape and provides an alternative opening in case of maintenance and repair.
- (g) Door viewers or sidelight must be provided at Dwelling Unit main entrances.
- (h) Window fall protection must be provided at all new and replacement window locations whenever lowest part of window opening is within 36-inches of floor.

PART 2 PRODUCTS

2.1 MANUFACTURERS

A. Vinyl Windows Basis of Design: Thermo-Tech Vinyl Windows and Doors; www.ttwindows.com.

1. Substitutions: See Section 01 6000 - Product Requirements.

2.2 DESCRIPTION

A. Vinyl Windows: Factory fabricated frame and sash members of extruded, hollow, ultra-violet-resistant, polyvinyl chloride (PVC) with integral color; with factory-installed glazing, hardware, related flashings, anchorage and attachment devices.

1. Configuration: As indicated on drawings.

a. Product Type: single hung at apartment units fixed at common areas.

2. Color: Color as selected.

3. Size to fit openings with minimum clearance around perimeter of assembly providing necessary space for perimeter seals.

4. Framing Members: Fusion welded corners and joints, with internal reinforcement where required for structural rigidity; concealed fasteners.

5. System Internal Drainage: Drain to exterior side by means of weep drainage network any water entering joints, condensation within glazing channel, or other migrating moisture within system.

6. Glazing Stops, Trim, Flashings, and Accessory Pieces: Formed of rigid PVC, fitting tightly into frame assembly.

B. Performance Requirements: Provide products that comply with the following:

1. Grade: AAMA/WDMA/CSA 101/I.S.2/A440 requirements for specific window type:

a. Performance Class (PC): LC.

2.3 COMPONENTS

A. Glazing: Insulated double pane, annealed glass, clear, low-E coated, argon filled, with glass thicknesses as recommended by manufacturer for specified wind conditions and acoustic rating indicated.

B. Operable Sash Weatherstripping: Wool pile; permanently resilient, profiled to maintain weather seal in accordance with AAMA 701/702.

C. Provide stops at all operable windows where the sill is less than 40 inches above the finish floor. Stops shall prevent the passage of a 4 inch sphere through the window when fully open.

D. Sealants for Setting Window Sill Pan Flashing: Provide butyl tape, non-hardening butyl, polyurethane, or silicone sealant; in compliance with ASTM E2112 installation practices.

E. Sliding Patio Doors: Basis of Design Thermo-Tech Slim Line Sliding Glass doors.

2.4 HARDWARE

A. Sash lock: Lever handle and keeper with cam lock, provide at least one for each operating sash.

PART 3 EXECUTION

3.1 EXAMINATION

A. Verify wall openings and adjoining air and vapor seal materials are ready to receive this work.

3.2 INSTALLATION

A. Install window unit assemblies in accordance with manufacturer's instructions and applicable building codes.

B. Attach window frame and shims to perimeter opening to accommodate construction tolerances and other irregularities as necessary.

C. Align window plumb and level, free of warp or twist, and maintain dimensional tolerances and alignment with adjacent work.

D. Set sill members and sill flashing in continuous bead of sealant.

E. Provide thermal isolation where components penetrate or disrupt building insulation. Pack fibrous insulation in shim spaces at perimeter of assembly to maintain continuity of thermal barrier.

F. Install operating hardware.

3.3 TOLERANCES

A. Maximum Variation from Level or Plumb: 0.06 inches every 3 ft (1.5 mm/m) non-cumulative or 0.5 inches per 100 ft (12 mm/30 m), whichever is less.

3.4 ADJUSTING

A. Adjust hardware for smooth operation and secure weathertight closure.

3.5 CLEANING

A. Remove protective material from pre-finished surfaces.

B. Wash surfaces by method recommended and acceptable to window manufacturer; rinse and wipe surfaces clean.

C. Remove excess glazing sealant by moderate use of mineral spirits or other solvent acceptable to sealant manufacturer and appropriate for application indicated.

PART 1 GENERAL REQUIREMENTS

The work in this section includes the furnishing of all finish hardware as described in the specification and as required by hardware group numbers as shown on the drawings; refer to door & hardware schedule. Refer to the general conditions, special conditions and instructions to bidders for other requirements.

- A. Hardware for wood, aluminum, and hollow metal doors.
- B. Hardware for fire-rated doors.
- C. Electrically operated and controlled hardware.
- D. Thresholds.
- E. Weatherstripping, seals and door gaskets.

1.1 RELATED WORK IN OTHER SECTIONS

- A. Section 06 20 00 - Finish Carpentry: Installation of Finish Hardware.
- B. Section 08 11 13 – Hollow Metal Doors and Frames.
- B. Section 08 11 00 - Metal Doors and Frames.
- C. Section 08 14 50 - Flush Wood Doors.
- C. Section 08 43 13 - Aluminum-Framed Storefronts: Hardware for doors in storefront, including:
 - 1. Integral weatherstripping.
- D. Section 08 36 00 – Entrance Doors Power Operator

1.2 SCHEDULES - SUBMITTALS

- A. Within fifteen (15) days after the contract is awarded and before any hardware is ordered, submit six (6) copies of a complete, detailed hardware schedule for review. If resubmissions are required, one (1) copy will be returned with proper notations resubmit four (4) copies. After final reviewed schedule is returned send copies and templates to fabricators requiring the same. The schedule cover page shall include the project name hardware supplier, firm name of general contractor, architectural firm, name and manufacturers reference list of symbols used to abbreviate names of hardware manufacturers.
- B. Catalog cuts of each piece of hardware shall accompany the hardware schedule.
- C. Schedule format shall be consistent with recommendations for a vertical format as set forth in the Door & Hardware Institute's (DHI) publication "Sequence and Format for the Hardware Schedule". Hardware sets shall be consolidated to group multiple door openings which share similar hardware requirements. Schedule shall include the following information:
 - 1. Door number, location, size, handing, and rating.
 - 2. Door and frame material, handing.
 - 3. Degree of swing.
 - 4. Manufacturer
 - 5. Product name and catalog number
 - 6. Function, type and style
 - 7. Size and finish of each item
 - 8. Mounting heights
 - 9. Explanation of abbreviations, symbols, etc.
 - 10. Numerical door index, indicating the hardware set/ group number for each door.
- D. When universal type door closers are to be provided, the schedule shall indicate the application method to be used for installation at each door: (regular arm, parallel arm, or top jamb).
- E. The schedule will be prepared under the direct supervision of a certified Architectural Hardware Consultant (AHC) employed by the hardware distributor. The hardware schedule shall be signed and embossed with the DHI certification seal of the supervising AHC. The supervising AHC shall attend any meetings related to the project when requested by the architect.
- F. Check the specified hardware for suitability and adaptability to the details and surrounding conditions.
- G. Review drawings from related trades as required to verify compatibility with specified hardware. Indicate unsuitable or incompatible items, and proposed substitutions in the hardware schedule.
- H. Provide documentation for all hardware to be furnished on labeled fire doors indicating compliance with positive pressure fire testing UL 10C.
- I. Furnish manufacturers' catalog data for each item of hardware in quantities as required by Division 01 - General Conditions.
- J. Submit a sample of each type of hardware requested by the architect. Samples shall be of the same finish, style, and function as specified herein. Tag each sample with its permanent location so that it may be used in the final work.
- K. Furnish with first submittal, a list of required lead times for all hardware items.
- L. After final approved schedule is returned, transmit corrected copies for distribution and field use in quantities as required by Division 01 - General Conditions.
- M. Furnish approved hardware schedules, template lists, and pertinent templates as requested by related trades.

087000 - 087100 FINISH HARDWARE

- N. Furnish necessary diagrams, schematics, voltage and amperage requirements for all electro-mechanical devices or systems as required by related trades. Wiring diagrams shall be opening specific and include both a riser diagram and point to point diagram showing all wiring terminations.
- O. After receipt of approved hardware schedule, Hardware supplier shall initiate a meeting including the owner's representative to determine keying requirements. Upon completion of the initial key meeting, hardware supplier shall prepare a proposed key schedule with symbols and abbreviations as set forth in the door and hardware institute's publication "Keying Procedures, Systems, and Nomenclature". Submit copies of owner approved key schedule for review and field use in quantities as required by Division 01 - General Conditions.
1. Keying to be determined by owner.
 2. Furnish two (2) change keys per door.
 3. All keying shall be done by the factory or by a registered locksmith where permanent keying records shall be kept.
- P. Wiring diagrams shall be included in final submittals transmitted for distribution and field use.

1.3 REFERENCE STANDARDS

- A. ADA Standards - Americans with Disabilities Act (ADA) Standards for Accessible Design; 2010.
- B. BHMA A156.18 - American National Standard for Materials and Finishes; 2012.
- C. ICC A117.1 - Accessible and Usable Buildings and Facilities; 2009.
- D. NFPA 80 - Standard for Fire Doors and Other Opening Protectives; 2016.
- E. NFPA 101 - Life Safety Code; 2015.
- F. UL (DIR) - Online Certifications Directory; current listings at database.ul.com.

1.4 DELIVERY, STORAGE, AND HANDLING

- A. Hardware supplier shall deliver hardware to the job site unless otherwise specified.
- B. All hardware shall be delivered in manufacturers' original cartons and shall be clearly marked with set and door number.
- C. Coordinate with contractor prior to hardware delivery and recommend secure storage and protection against loss and damage at job site.
- D. Contractor shall receive all hardware and provide secure and proper protection of all hardware items to avoid delays caused by lost or damaged hardware. Contractor shall report shortages to the hardware supplier immediately after receipt of material at the job site.
- E. Coordinate with related trades under the direction of the contractor for delivery of hardware items necessary for factory installation.

1.5 COORDINATION

- A. Templates: Distribute door hardware templates for doors, frames, and other Work specified to be factory prepared for installing door hardware. Check Shop Drawings of other Work to confirm that adequate provisions are made for locating and installing door hardware to comply with indicated requirements.
- B. Furnish a final hardware schedule and templates to door frame suppliers. If required, the hardware supplier shall furnish physical hardware to the door and frame manufacturers for application.
- C. All reinforcements required to adapt hardware to metal doors or frames shall be supplied by the door and/or frame manufacturers.
- D. Electrical System Roughing-in: Coordinate layout and installation of electrified door hardware with connections to power supplies, fire alarm system and detection devices, access control system, security system, and building control system.
1. Prior to installation of electronic hardware, arrange conference between door hardware, and door/frame supplier, installers and related trades to review materials, procedures and coordinating related work.

1.6 PRE-INSTALLATION MEETING

- A. Schedule a hardware pre-installation meeting on site to review and discuss the installation of continuous hinges, locksets, door closers, exit devices, overhead stops, and electromechanical door hardware.
- B. Meeting attendees shall be notified 7 days in advance and shall include: Architect, Contractor, Door Hardware Installers (including low voltage hardware), Manufacturers representatives for above hardware items, and any other effected subcontractors or suppliers.
- C. All attendees shall be prepared to distribute installation manuals, hardware schedules, templates, and physical hardware samples.

1.7 WARRANTY

- A. See Section 01 7800 - Closeout Submittals, for additional warranty requirements.
- B. All hardware items shall be warranted against defects in material and workmanship as set forth in Division One General Requirements.
- C. Repair, replace, or otherwise correct deficient materials and workmanship without additional cost to owner.

PART 2 PRODUCTS

2.1 DOOR HARDWARE - GENERAL

- A. Provide hardware specified or required to make doors fully functional, compliant with applicable codes, and secure to the extent indicated.
- B. Provide items of a single type of the same model by the same manufacturer.
- C. Provide products that comply with the following:
1. Applicable provisions of federal, state, and local codes.
 2. Accessibility: ADA Standards and ICC A117.1.
 3. Applicable provisions of NFPA 101, Life Safety Code.
 4. Fire-Rated Doors: NFPA 80.
 5. Hardware on Fire-Rated Doors, Except Hinges: Listed and classified by UL (DIR) as suitable for the purpose specified and indicated.
 6. Hardware for Smoke and Draft Control Doors (Indicated as "S" on Drawings): Provide hardware that enables door assembly to comply with air leakage requirements of the applicable code.
 6. Products Requiring Electrical Connection: Listed and classified by UL (DIR) as suitable for the purpose specified and indicated.
- D. Electrically Operated and/or Controlled Hardware: Provide all power supplies, power transfer hinges, relays, and interfaces required for proper operation; provide wiring between hardware and control components and to building power connection.
- E. Finishes: Provide door hardware of the same finish unless otherwise indicated.
1. Finish: Satin oxidized bronze, oil rubbed, on bronze base metal, 613 (approx US10B).
 2. Finish Definitions: BHMA A156.18.
 3. Exceptions:
 - a. Where base metal is specified to be different, provide finish that is an appearance equivalent according to BHMA A156.18.
 - b. Hinges for Fire-Rated Doors: Steel base metal with painted finish.
 - c. Aluminum Surface Trim and Gasket Housings: Anodized to match door, not to match other hardware.
- F. Fasteners:
1. All exposed fasteners shall be Phillips head or as otherwise specified and shall match the finish of the adjacent hardware. All fasteners exposed to the weather shall be non-ferrous or stainless steel. Furnish correct fasteners to accommodate surrounding conditions.
 2. Coordinate required reinforcements for doors and frames. Seek approval of the architect prior to furnishing through-bolts. Furnish through-bolts as required for materials not readily reinforced.

2.2 HINGES

- A. Acceptable manufacturers and respective catalog numbers: Ives Stanley Hager McKinney
Standard Weight, Plain Bearing 5PB1 F179 1279 T2714
Standard Weight, Ball Bearing 5BB1 BB179 BB1279 TB2714
Standard Weight, Ball Bearing, Non-Ferrous 5BB1 FBB191 BB1191 TB2314
Heavy Weight, Ball Bearing 5BB1HW FBB168 BB1168 T4B3786
Heavy Weight, Ball Bearing, Non-Ferrous 5BB1HW FBB199 BB1199 T4B3386
- B. Quantity of Hinges Per Door:
1. Doors From 60 inches (1.5 m) High up to 90 inches (2.3 m) High: Three hinges.
 2. Doors 90 inches (2.3 m) High up to 120 inches (3 m) High: Four hinges.
- C. Unless otherwise specified, top and bottom hinges shall be located as specified in Division 08 Section "Hollow Metal Doors and Frames". Intermediate hinges shall be located equidistant from others.
- D. Unless otherwise specified, furnish hinge weight and type as follows:
1. Standard weight: plain bearing hinge 5PB1 for interior openings through 36 inches wide without a door closer.
 2. Standard weight: ball bearing hinge 5BB1 for interior opening over 36 through 40 inches wide without a door closer, and for interior openings through 40 inches wide with a door closer.
 3. Heavyweight: 4 ball bearing hinge 5BB1HW for interior openings over 40 inches wide, and for all vestibule doors.
 4. Heavyweight: 4 ball bearing hinge 5BB1HWss for exterior openings unless otherwise listed in groups.
- E. Unless otherwise specified, furnish hinges for exterior doors, fabricated from brass, bronze, or stainless steel. Unless otherwise specified, hinges for interior doors may be fabricated from steel.
- F. Unless otherwise specified, furnish hinges in the following sizes:
1. 5" x 5" 2-1/4" thick doors
 2. 4-1/2" x 4-1/2" 1-3/4" thick doors
 3. 3-1/2" x 3-1/2" 1-3/8" thick doors
- G. Furnish hinges with sufficient width to accommodate trim and allow for 180-degree swing.

087000 - 087100 FINISH HARDWARE

H. Unless otherwise specified, furnish hinges with flat button tips with non-rising pins at interior doors, non-removable loose pins (NRP) at exterior and out-swinging interior doors.

I. Unless otherwise specified, furnish all hinges to template standards.

2.3 SPRING HINGES

A. Self-Closing Hinges: Comply with ANSI/BHMA A156.17. Listed under Category A in BHMA's "Certified Product Directory."

1. Provide UL fire tested and listed hinges for labeled doors up to and including Class "A." Comply with NFPA 80 requirements for spring hinges on fire-rated doors.

2. Acceptable Manufacturers:

Bommer Hager McKinney Stanley Ives PBB

(0.134) Steel LB4310 1250 1502 2060R 3SP1 RS81

(0.134) Stainless LB4390 1150 1552 2060R 3SP1 BB81

3. Substitutions: See Section 01 6000 - Product Requirements.

2.4 CONTINUOUS PIN AND BARREL HINGES

A. Acceptable manufacturers and respective catalog numbers:

Ives Markar Stanley McKinney

Edge Mount Pin & Barrel Stainless Steel

Continuous Hinge 700 Series 300 Series 650 Series 300 Series

B. Continuous hinges shall be full height pin and barrel type hinge providing full height door support up to 600 lbs.

Edge mount (unless noted otherwise).

C. Construct hinges of heavy-duty 14-gauge material. The stainless internal pin shall have a diameter of 0.25 and the exterior barrel diameter of 0.438.

D. Hinge shall be non-handed with symmetrical template hole pattern and factory drilled. Hinge must accept a minimum of 21 fasteners on the door and 21 fasteners on the frame.

E. Each knuckle to be 2 inch, including split nylon bearing at each separation for quiet, smooth, self-lubricating operation.

F. Hinge to be able to carry Warnock Hersey Int. or UL for fire rated doors and frames up to 3 hours.

G. Provide machine screws for doors which have been reinforced to accept machine screws.

H. Note: Fire label for doors and frames should be placed on the header and top rail of fire rated doors and frames.

2.5 POWER TRANSFERS

A. Acceptable manufacturers and respective catalog numbers:

Von Duprin ASSA

Concealed Two Wire EPT-2 CEPT-10

Concealed Ten Wire EPT-10 CEPT-10

B. Concealed power transfers shall be concealed in the door and frame when the door is closed.

C. Concealed power transfers shall have a steel tube to protect wires from being cut.

D. Concealed power transfers with spring tubes shall be rejected.

E. Concealed power transfers shall be supplied with a mud box to house all terminations.

2.6 LOCKS AND LATCHES

A. Acceptable manufacturers and respective catalog numbers:

Schlage Sargent Corbin Best

Grade 1 Cylindrical ND Series SPA 10 Line LP CL3300 PZD 9K Series 14D

Grade 1 Mortise L9000 Series 17A 8200 Series

LNP

ML2000

Series PS

45H Series 14H

B. Minimize transmission of heat to lock trim. Provide temperature control modules (TCM) on all electrified locks when cataloged by the lock manufacturer.

C. Unless otherwise specified, all locks and latches to have:

1. 2-3/4" Backset

2. 1/2" minimum throw latchbolt

3. 1" throw deadbolt

4. 6 pin cylinders

5. ANSI A115.2 strikes

D. Provide guarded latch bolts for all locksets, and latch bolts with sufficient throw to maintain fire rating of both single and paired door assemblies.

E. Length of strike lip shall be sufficient to clear surrounding trim.

F. Provide wrought boxes for strikes at inactive doors, wood frames, and metal frames without integral mortar covers.

2.7 MAGNETIC LOCKS

A. Acceptable manufacturers and respective catalog numbers:

Schlage Electronics Securitron
Direct Hold M490 Series 82B

B. Provide magnetic locks as specified, complete with mounting brackets and fasteners appropriate to the application.

Direct Hold magnetic locks shall have a minimum of 1500 lbs holding force.

C. Provide magnetic locks with integral magnetic bond sensor, time delay (1-90 Seconds) for re-locking, and LED status indicator as noted in hardware groups.

D. Provide regulated and filtered power supplies for magnetic locks by the same manufacturer.

2.8 DOOR POSITION SWITCHES

A. Acceptable manufacturers and respective catalog numbers:

Schlage Electronics Sentrol Sargent
Concealed (wood and hollow metal doors) 679 Series 1076W 3287

2.9 ELECTRIC STRIKES

A. Acceptable manufacturers and respective catalog numbers:

Von Duprin Folger Adams Type 1 6000 Series 300 Series

B. Provide electric strikes designed for use with the type of locks shown at each opening where specified.

C. Electric strikes shall be UL listed as Burglary-Resistant Electric Door Strikes and where required shall be UL listed as Electric Strike for Fire Doors.

D. Provide transformers and rectifiers for each strike as required. Verify voltage with electrical contractor.

2.10 POWER SUPPLIES

A. Provide quantities and types as specified in hardware sets. Shared power supplies will not be accepted without prior approval from the owner.

B. All power supplies shall have the following features:

1. 12/24 VDC Output, field selectable.
2. Class 2 Rated power limited output.
3. Universal 120-240 VAC input.
4. Low voltage DC, regulated and filtered.
5. Polarized connector for distribution boards.
6. Fused primary input.
7. AC input and DC output monitoring circuit w/LED indicators.
8. Cover mounted AC Input indication.
9. Tested and certified to meet UL294.
10. NEMA 1 enclosure.
11. Hinged cover w/lock down screws.
12. High voltage protective cover.

C. All power supplies shall incorporate fused distribution boards.

D. All electro-mechanical systems requiring fail safe circuits shall be capable of interfacing with the fire alarm system to cut power to appropriate system components. Unless already provided in another system component, all power supplies utilized in fail safe circuits shall include an integral relay which when connected to the N/C fire alarm contact will cut power to all openings connected to the individual power supply. Power supply, unless otherwise specified, will automatically reset itself when fire alarm relay returns to normal state following a fire alarm.

2.11 FLUSH BOLTS AND DUST PROOF STRIKES

A. Acceptable manufacturers and respective catalog numbers:

Ives Door Controls Hager Rockwood
Dust Proof Strike DP2 80 280X 570
Auto Flush Bolt (Metal Door) FB31P 842 292D 2842
Auto Flush Bolt (Wood Door) FB41P 942 291D 2942
Manual Flush Bolt FB458 780 282D 555

B. Unless otherwise specified, provide 12" rods for manual flush bolts for door 7'6" or less, 24" top rods for doors over 7'6" to 8'6".

C. Unless otherwise specified, provide doors over 8'6" with automatic top bolts.

D. Provide automatic flush bolts where required to maintain fire door listing and or egress requirements on pairs of doors.

E. All flush-bolt applications shall be UL listed to be installed with top flush-bolt only. Provide auxiliary fire bolt as required for fire rated openings where less bottom bolt has been specified.

F. Provide all bottom flush bolts with non-locking dust proof strikes.

087000 - 087100 FINISH HARDWARE

2.12 EXIT DEVICES

A. Acceptable manufacturers and respective catalog numbers:

Von Duprin Sargent Detex
Wide Stile, Push Pad 98/99 Series GL-43-80 Series Advantex (Wide Stile)
Wide Stile, Electric Latch
Retraction
QEL 98/99 Series GL-43-56-80 Series Advantex-ER (Wide Stile)
Lever Trim 996 Series 740 ET "D/DM" Trim
Pull Trim 990 Series 800 MAL "C" Trim

B. Obtain exit devices from a single manufacturer, although several may be indicated as offering products complying with requirements.

C. All exit devices shall be equipped with a sound-dampening feature to reduce touch pad return noise.

D. Quiet Electric Latch Retraction shall be accomplished using a motor driven assembly, and shall incorporate the following features:

1. Motor shall retract both the push pad assembly and latchbolt.
2. Automatic calibration of latch throw and pull.
3. Built-in time delay.
4. On-board installation and troubleshooting diagnostics built into power supply and device.
5. Retry mode if device does not pull on the first try.

E. All exit devices shall be provided with flush end caps to reduce potential damage from impact.

F. All exit devices shall be provided with dead-locking latch bolts to insure security.

G. All exit devices shall be U.L. listed for accident hazard. Exit device for use on fire doors shall also be U.L. listed for fire exit hardware.

H. Provide optional strikes, special length rods, and adapter plates to accommodate door and frame conditions. Provide narrow style series devices in lieu of wide stile series devices where optional strikes will not accommodate door and frame conditions.

I. Coordinate with related trades to insure adequate clearance and reinforcement is provided in doors and frames. Provide thru bolts as required.

J. Refer to hardware groups for exit device applications utilizing the option of: "less bottom rod and floor strike" (LBR)

K. All exit devices shall be provided with optional trim designs to match other lever and pull designs used on the project.

L. Unless specific exit device dogging options are noted within hardware sets, provide dogging options as follows:

1. Fire Rated devices: Dogging not permitted.
2. Non-Rated Exit Only functions not equipped with outside trim or pull: Less Dogging.
3. Non-Rated Classroom functions: Less Dogging.
4. Non-Rated devices utilizing electric latch retraction or electrified outside trim: Less Dogging.
5. All Other Non-Rated devices: Cylinder Dogging utilizing interchangeable core cylinders. Cylinder keyway shall match locksets furnished on this project.

M. Provide glass bead kits as required to accommodate door conditions. Screws shall not be visible through full glass doors.

N. Where specified, provide compatible keyed mullions with cylinder for pairs of doors.

O. Provide reinforced crossbars for all traditional style exit devices applied to doors over 36" wide.

2.13 CLOSERS

A. Acceptable manufacturers and respective catalog numbers:

LCN Norton Sargent Corbin
4050/4050 EDA R7500/PR7500 351/351P10 DC8000 A10/DC8000 A3



B. Obtain door closers from a single manufacturer, although several may be indicated as offering products complying with requirements.

C. Provide extra heavy duty arm (EDA / HD) when closer is to be installed using parallel arm mounting.

D. Hardware supplier shall coordinate with related trades to insure aluminum frame profiles will accommodate specified door closers.

E. Closers shall use high strength cast cylinders, forged main arms, and 1 piece forged steel pistons.

F. Closers shall utilize a stable fluid withstanding temperature range of +120 deg F to -30 deg F without seasonal adjustment of closer speed to properly close the door. Closers for fire-rated doors shall be provided with temperature stabilizing fluid that complies with standards UL10C.

G. Unless otherwise specified, all door closers shall have full covers and separate adjusting valves for sweeps, latch, and backcheck.

H. Provide closers for all labeled doors. Provide closer series and type consistent with other closers for similar doors specified elsewhere on the project.

I. Provide closers with adjustable spring power. Size closers to insure exterior and fire rated doors will consistently close and latch doors under existing conditions. Size all other door closers to allow for reduced opening force not to exceed 5 lbs.

J. Install closers on the room side of corridor doors, stair side of stairways and interior side of exterior doors.

K. Closers shall be furnished complete with all mounting brackets and cover plates as required by door and frame conditions, and by adjacent hardware.

L. Door closers shall be provided with a powder coat finish to provide superior protection against the effects of weathering. Powder coat finish shall successfully pass a 100 hour salt spray test.

M. Pressure Relief Valve, PRV, shall not be acceptable.

2.14 LOW ENERGY ELECTRO-HYDRAULIC AUTOMATIC OPERATORS

- A. Acceptable manufacturers and respective catalog numbers: LCN Besam
Electro-Hydraulic Operator 4640 PowerSwing
- B. Where low kinetic energy, as defined by ANSI/BHMA Standard A156.19, power operators are indicated for doors required to be accessible to the disabled, provide electrically powered operators complying with the ADA for opening force and time to close standards.
- C. The closing action shall be controlled by modern type cast iron door closer cylinder filled with a flat viscosity fluid, stable from +120F to -30F that would require no seasonal adjustments. The closer shall have field adjustable spring power; have two independent closing speed adjustment valves, and hydraulic back-check.
- D. Full closing force shall be provided when the power or assist cycle ends.
- E. All power operator systems shall include the following features and functions:
1. Provisions for separate conduits to carry high and low voltage wiring in compliance with the National Electrical Code, section 725-31.
 2. The operator will be designed with an electronically controlled mechanical clutching mechanism to prevent damage to the operator if the system is actuated while the door is latched or if the door is forced closed during the opening cycle.
 3. All covers, mounting plates and arm systems shall be powder coated and successfully pass a minimum of 100 hours testing as outlined in ANSI/BHMA Standard A156.18.
 4. UL listed for use on labeled doors.
 5. All operators shall be non-handed with spring power over a range of at least four sizes; either 1 through 4 or 2 through 5.
 6. The power operator shall incorporate microprocessor controlled digital controls including: factory default memory settings, on-board diagnostics, non-volital memory, and integrated delay and relay for controlling door release devices.
 7. Provisions in the control box or module shall provide control inputs and outputs) for; electric strike delay, auxiliary contacts, sequential operation, fire alarms systems, actuators, swing side sensors, and stop side sensors.
 8. Wall mounted actuators shall consist of a 4-1/2 inch diameter stainless steel touch plate with a blue filled handicapped symbol. Switches shall be weather resistant and mount on a single gang electrical box furnished by Division 26.
- F. All electrically powered operators shall include the following features or functions:
1. When an obstruction or resistance to the opening swing is encountered, the operator will pause at that point, then attempt to continue opening the door. If the obstruction or resistance remains, the operator will again pause the door.
 2. Easily accessible main power and maintain hold open switches will be provided on the operator.
 3. An electronically controlled clutch to provide adjustable opening force.
 4. A microprocessor to control all motor and clutch functions.
 5. An on-board power supply capable of delivering both 12V and 24V outputs up to a maximum of 1.0 ampere combined load.
 6. All input and output power wiring shall be protected by slow blow fuses. These fuses shall be easily replaceable without special tools or component replacement.
 7. If electrical failure occurs, the unit shall operate as a standard door closer.
- G. Power Operators shall be warranted by the manufacture to be free from defects in material and workmanship for a period of two years.

2.15 OVERHEAD STOPS

- A. Acceptable manufacturers and respective catalog numbers: Glynn-Johnson Rixson Sargent
Heavy Duty Surface Mount GJ900 Series 9 Series 590
Heavy Duty Concealed Mount GJ100 Series 1 Series 690
- B. Overhead stops (including slide block and end caps) shall be fabricated from metal.
- C. Unless otherwise specified, furnish GJ900 series overhead stop for doors equipped with regular arm surface type closers that swing more than 140 degrees before striking a wall, for doors that open against equipment, casework, sidelights, or other objects that would make wall bumpers inappropriate, and as specified in hardware groups.
- D. Furnish sex bolt attachments for wood and mineral core doors unless doors are supplied with proper reinforcing blocks.
- E. Provide special stop only ("SE" suffix) overhead stops when used in conjunction with electronic hold open closers.
- F. Do not provide holder function for labeled doors.

2.16 WALL STOPS AND HOLDERS

- A. Acceptable manufacturers and respective catalog numbers: Ives Hager Burns Rockwood
Wrought Convex Wall Bumper WS406CVX 232W 570 406
Wrought Concave Wall Bumper WS406CCV 236W 575 409
Automatic Wall Holder WS40 326W 533 490
- B. Furnish a stop or holder for all doors. Furnish floor stops or hinge pin stops only where specifically specified.
- C. Where wall stops are not applicable, furnish overhead stops.
- D. Do not provide holder function for labeled doors.

2.17 MAGNETIC HOLD OPENS

- A. Acceptable manufacturers and respective catalog numbers: LCN ABH Edwards
Wall Holder SEM 7800 2000 1500
- B. Magnetic holder's housing and armature shall be constructed of a die cast zinc material.
- C. Provide types as listed in groups.
- D. Where wall conditions do not permit the armature to reach the magnet, provide extensions.
- E. Provide proper voltage and power consumption as required by Division 26.
- F. Coordinate electrical requirements and mounting locations with other trades.

2.18 WEATHERSTRIP, GASKETING

- A. Acceptable manufacturers and respective catalog numbers: Zero Pemko NGP Reese
Weatherstrip 429 2891_PK 700NA 755
Adhesive Gasket 188S S88 5050 797
Mullion Seal/Silencer 8780 5110 5100N
Meeting Edge Seals 8193 18041 9605 959
Automatic Door Bottom (hard surface)
360 434_RL 423N 430
Automatic Door Bottom (carpet) 360 434_NBL 683 943
Automatic Door Bottom 355 420APKL 320N 372A
Sweeps 8192 18061_NB B606 964
Sweep w/ Drip 8198 345_N C627 354
Drip Cap 142 346 16 R201
- B. Where specified in the hardware groups, furnish the above products unless otherwise detailed in groups.
- C. Provide weatherstripping all exterior doors and where specified.
- D. Provide intumescent and other required edge sealing systems as required by individual fire door listings to comply with positive pressure standards UL 10C.
- E. Provide Zero 188S smoke gaskets at all fire rated doors and smoke and draft control assemblies.
- F. Provide gasketing for all meeting edges on pairs of fire doors. Gasketing shall be compatible with astragal design provided by door supplier as required for specific fire door listings.

2.19 THRESHOLDS

- A. Acceptable manufacturers and respective catalog numbers: Zero Pemko NGP Reese
Saddle Thresholds 8655 171 425 S205
- B. Hardware supplier shall verify all finish floor conditions and coordinate proper threshold as required to insure a smooth transition between threshold and interior floor finish.
- C. Threshold Types:
 - 1. Unless otherwise specified, provide saddle threshold similar to Zero 8655 for all exterior openings with an interior floor finish less than or equal to 1/4" in height.
 - 2. Unless otherwise specified, provide half saddle threshold similar to Zero 1674 for all exterior openings with an interior floor finish greater than 1/4" in height. Threshold height shall match thickness of interior floor finish.

2.20 PULLS, PUSH BARS, PUSH/PULL PLATES

- A. Acceptable manufacturers and respective catalog numbers: Burns Hager Rockwood Ives
Straight Pull (1" dia. 10" ctc) 26C 4J 111 8103-0
Straight Pull (3/4" dia. 8" ctc) 25B 3G 107 8102-8
Offset Door Pull (1" dia. 10" ctc) 39C 12J BF157 8190-0
Pull/Push Bar (1" dia. 10" ctc Pull) 422 x 26C 153 11147 9103-0
Offset Pull/Push Bar (1" dia. 10" ctc Pull) 422 x 39C 157 BF15747 9190-0
Push Plate (0.050 4" x 16") 54 30S 4 x 16 70C 8200 4" x 16"
Push Plate (0.050 6" x 16") 56 30S 6 x 16 70E 8200 6" x 16"
Pull Plate (1" dia. 10" ctc - 0.050" x 4" x 16") 5426C 34J 4 x 16 111 x 70C 8303-0 4" x 16"
- B. Adjust dimensions of push plates to accommodate stile and rail dimensions, lite and louver cutouts, and adjacent hardware. Where required by adjacent hardware, push plates shall be factory drilled for cylinders or other mortised hardware. All push plates shall be beveled 4 sides and counter sunk.
- C. Where possible, provide back-to-back, and concealed mounting for pulls and push bars. Push bar length shall be 3" less door width, or center of stile to center of stile for stile & rail or full glass doors.

2.21 COORDINATORS

A. Acceptable manufacturers and respective catalog numbers:

Ives Door Controls Hager Rockwood
Bar Coordinator COR x FL 600 x Filler 297D x 297F 2600 Series
Mounting Bracket MB Series AB, C Series 297 Series 2600 Series

B. Provide coordinators at all pairs of doors having automatic flush bolts and closers on the inactive leaf, and for pairs of doors having vertical rod/mortise exit device combinations with overlapping astragals.

C. Provide appropriate filler bars, closer mounting brackets, carry bars, and special top latch preparations as required by adjacent hardware.

2.22 KICK PLATES AND MOP PLATES

A. Acceptable manufacturers and respective catalog numbers:

Rockwood Hager Ives Hiawatha
Kick Plate K1050 190S 8400 J102

B. Furnish protective plates as specified in hardware groups.

C. Where specified, provide 10" kick plates, 34" armor plates, and 4" mop plates. Unless otherwise specified, metal protective plates shall be .050" thick; plastic plates shall be 1/8" thick.

D. Protective plates shall be 2" less door width, or 1" less door width at pairs. All protective plates shall be beveled 4 sides and counter sunk. Protection plates over 16" shall not be provided for labeled doors unless specifically approved by door manufacturers listing.

E. Where specified, provide surface mounted door edges. Edges shall butt to protective plates. Provide edges with cutouts as required adjacent hardware.

F. Adjust dimensions of protection plates to accommodate stile and rail dimensions, lite and louver cutouts, and adjacent hardware. Where required by adjacent hardware, protection plates shall be factory drilled for cylinders or other mortised hardware.

2.23 SLIDING DOOR HARDWARE

A. Acceptable Manufacturers and respective catalog numbers:

KN Crowder
Face Mounted Track C412
Fascia C413
Hangers C411
Door Guides C913
Door Guide Channel C914
Angle Stop C100

B. Provide complete hardware sets for each opening specified with sliding door hardware. Include track, ball-bearing hangers, door stops, fasteners, guides, and all hardware required for a complete installation.

C. Hardware supplier shall coordinate with related trades to insure that wall pocket framing will accommodate specified hardware.

2.24 KEYING

A. Acceptable manufacturers and respective catalog numbers:

Schlage Sargent Corbin
Everest 29 Degree Access

B. Provide all locks and cylinders utilizing a patented keyway to prevent manufacturing and distribution of aftermarket key blanks by anyone other than factory authorized dealers.

C. All locks under this section shall be keyed as directed by the owner to a new Patented Grand Master Key System.

D. Keying shall be by lock manufacturer where permanent records shall be kept.

E. Furnish a total of 2 keys per cylinder. Actual cut keys to be determined by owner.

F. Master keys and control keys to be delivered by registered mail to the owner. Change keys shall be delivered in a set up key cabinet. Construction keys shall be delivered to the contractor.

2.25 KEY CABINETS

A. Acceptable manufacturers and respective catalog numbers:

Lund Key Control Telkee
1200-1205 AA M228-2480 RWC-AWC

B. Furnish 1 each model 1200 or 1205 AA key cabinet with a capacity 1.5 times the number of key sets.

C. Provide one key cabinet with at least one hook for each key set, plus additional hooks for 50% expansion.

D. Furnish key cabinet complete with cam lock, permanent key tags, and change key cards.

E. Hardware supplier shall prepare all key change index records, tag all keys and place permanent file keys in cabinet.

PART 3 EXECUTION

3.1 EXAMINATION

- A. Verify that doors and frames are ready to receive work; labeled, fire-rated doors and frames are present and properly installed, and dimensions are as indicated on shop drawings.
- B. Verify that electric power is available to power operated devices and of the correct characteristics.
- C. Prior to installation of hardware, installer shall examine door frame installation to insure frames have been set square and plumb. Installer shall examine doors, door frames, and adjacent wall, floor, and ceiling for conditions, which would adversely effect proper operation and function of door assemblies. Do not proceed with hardware installation until such deficiencies have been corrected.

3.2 INSTALLATION

- A. Before hardware installation, general contractor/construction manager shall coordinate a hardware installation seminar with a 1 week notice to all parties involved. The seminar is to be conducted on the installation of hardware, specifically of locksets, closers, exit devices, continuous hinges and overhead stops. Manufacturer's representative of the above products to present seminar. Seminar to be held at the job site and attended by installers of hardware (including low voltage hardware) for aluminum, hollow metal and wood doors. Training to include use of installation manuals, hardware schedule, templates and physical products samples.
- B. Install all hardware in accordance with the approved hardware schedule and manufacturer's instructions for installation and adjustment.
- C. Set units level, plumb and true to the line and location. Adjust and reinforce the attachment substrate as necessary for proper installation and operation.
- D. Drill and countersink units which are not factory-prepared for anchorage fasteners. Space fasteners and anchors in accord with industry standards.
- E. Drill appropriate size pilot holes for all hardware attached to wood doors and frames.
- F. Shim doors as required to maintain proper operating clearance between door and frame.
- G. Unless otherwise specified, locate all hardware in accordance with the recommended locations for builders hardware for standard doors and frames as published by the Door and Hardware Institute.
- H. Use only fasteners supplied by or approved by the manufacturer for each respective item of hardware.
- I. Mortise and cut to close tolerance and conceal evidence of cutting in the finished work.
- J. Conceal push and pull bar fasteners where possible. Do not install through bolts through push plates.
- K. Install hardware on UL labeled openings in accordance with manufacturer's requirements to maintain the label.
- L. Apply self-adhesive gasketing on frame stop at head & latch side and on rabbet of frame at hinge side.
- M. Install hardware in accordance with supplemental "S" label instructions on all fire rated openings.
- N. Install wall stops to contact lever handles or pulls. Do not mount wall stops on casework, or equipment.
- O. Where necessary, adjust doors and hardware as required to eliminate binding between strike and latch bolt. Doors should not rattle.
- P. Overhead stops used in conjunction with electrified hold open closers shall be templated and installed to coincide with engagement of closer hold open position.
- Q. Install door closers on corridor side of lobby doors, room side of corridor doors, and stair side of stairways.
- R. Adjust spring power of door closers to the minimum force required to insure exterior and fire rated doors will consistently close and latch doors under existing conditions. Adjust all other door closers to ensure opening force does not to exceed 5 lbs.
- S. Adjust "sweep", "latch", & "back check" valves on all door closers to properly control door throughout the opening and closing cycle. Adjust total closing speed as required to comply with all applicable state and local building codes.
- T. Install "hardware compatible" (bar stock) type weatherstripping continuously for an uninterrupted seal. Adjust templating for parallel arm door closers, exit devices, etc., as required to accommodate weatherstripping.
- U. Unless otherwise specified or detailed, install thresholds with the bevel in vertical alignment with the outside door face. Notch and closely fit thresholds to frame profile. Set thresholds in full bed of sealant.
- V. Compress sweep during installation as recommended by sweep manufacturer to facilitate a water-resistant seal.
- W. Deliver to the owner 1 complete set of installation and adjustment instructions, and tools as furnished with the hardware.

3.3 CLEANING

- A. Clean adjacent surfaces soiled by hardware installation. Clean finished hardware per manufacturer's instructions after final adjustments has been made. Replace items that cannot be cleaned to manufacturer's level of finish quality at no additional cost.

3.4 PROTECTION

- A. Protect finished Work under provisions of Section 01 7000 - Execution and Closeout Requirements.
- B. Do not permit adjacent work to damage hardware or finish.

3.5 HARDWARE SETS; as shown on drawings door schedule.

PART 2 PRODUCTS

2.1 HARDWARE

A. Hardware shall include all necessary fasteners. All fasteners shall be of the proper type, size, material and finish for its intended purpose, All screws, exposed either when the door is open or closed shall have phillips heads.

2.2 HINGES

A. The following is a list of butt types which are considered acceptable:

HAGER LAWRENCE MCKINNEY STANLEY

TYPE 1 BB1199 BB5151A T4B3386 FBB199

TYPE 2 BB1168 BB5151 T4B3786 FBB168

TYPE 3 BB1279 BB4101 TB2714 FBB179

TYPE 4 1279 4101 2714 F179

TYPE 5 BB1191 BB4101A TB2314 FBB191

TYPE 6 1 250 9168 1502 2060

B. Ball bearing butts shall be furnished for all exterior doors, doors with closers, and doors over 36" wide.

C. Butt types shall be furnished as follows:

Exterior Outswinging Doors Type 1 x NRP

Interior Doors over 3'0 Wide Type 2

Interior Doors thru 3'0 Wide Type 3 or 4

D. Butt quantities and sizes shall be as follows:

Two butts for doors up to 5'0" high.

Provide one butt for every 30" of height unless otherwise indicated in spec groups.

1 3/4" Interior Doors 4 1/2" x 4 1/2"

1 3/4" Exterior Doors 4 1/2" x 4 1/2"

E. Provide proper butt width to clear trim and allow full 180 degree swing.

F. All butts shall have flat tips unless noted otherwise.

2.3 LOCKSETS AND LATCHSETS

A. Locksets and latchsets shall be heavy duty cylindrical type which meet the quality and design of those shown below:

(1) ACCEPTABLE MANUFACTURERS:

BRAND SERIES DESIGN SCHLAGE F SERIES FLAIR

CORBIN EQUAL YALE EQUAL

B. Locksets, latchsets, trim and cylinders shall be the product of one manufacturer unless otherwise indicated above. Cylinders shall have 6 pin tumblers. Unless otherwise indicated, all locksets, deadlocks and latchsets shall have 2 3/4" backsets. Bolt throw on pairs of doors shall be not less than 5/8". Lever handle locksets and latchsets with base metal other than aluminum shall have U.L. required fire stop to prevent latchbolt from returning into the lock body during fire.

C. Provide wrought boxes and strikes with proper length to protect trim not to project more than 1/8" beyond trim, frame or inactive leaf. Where required, provide open back strike to allow practical and secure operation. Provide knurled knobs at doors to stairs other than exit stairs, loading platforms, boiler rooms, stages and doors to other hazardous locations.

2.4 STOPS AND HOLDERS

A. Furnish a stop or holder for each door whether or not equipped with a closer.

1. Interior doors requiring a stop shall have one of the following as indicated by conditions: 50W, 60W, WB11, WB11A, RB3, RB4, RB6 or 560 series.

NOTE: Use 560 Series when an overhead stop is required on labeled doors. Use 360 Series, when required, on lead-lined doors. If closer is used CUSH or HCUSH arm is acceptable. Floor or base stops shall be used only where definitely specified or absolutely unavoidable.

2. Interior doors requiring a holder shall have one of the following as indicated by surrounding conditions: W20, W20A, W40, 570 series.

3. Exterior and vestibule doors requiring a stop and holder shall have one of the following as indicated by surrounding conditions: W20, or 90M series.

4. Exterior doors opening against a 1 1/2" or 2" pipe rail shall be furnished with a W20 x pipe adapter block, where conditions allow.

5. Doors which are capable of swinging more than 110 degrees before striking a wall shall have overhead type stop.

2.6 THRESHOLDS

Thresholds shall not to exceed 1/2" in height, unless specified or detailed otherwise. Color: clear anodized.

2.7 WEATHERSTRIPPING

A. Unless otherwise indicated, weather stripping shall be closed cell sponge neoprene, similar to Reese DS70. Apply weather stripping to heads and jambs of exterior frames. Color: dark bronze anodized.

B. Sweep strips shall be similar to Reese 323, extruded aluminum frame with 1/8" solid sponge neoprene having at least 3/8" drop. Color: clear anodized.

THRESHOLD AND WEATHERSTRIPPING MANUFACTURERS: REESE, PEMKO, NATIONAL GUARD, ZERO

C. Drip: Reese R201A

PART 3 APPLICATION

A. Install hardware in accordance with manufacturers printed instructions at mounting heights as described in the Door and Hardware Institute's "Recommended Locations for Builders' Hardware for Standard Steel Doors and Frames" or "Recommended Locations for Builders' Hardware for Custom Steel Doors and Frames."

B. Holes and mortises in wood doors for locks and other hardware shall be cut with a jig approved or provided by the manufacturer of the item applied. All locks shall be mounted so the key enters the cylinder with the smooth side down. After hardware has been fitted, escutcheons and face-applied hardware shall be removed or masked until final painting has been completed. Hardware shall be reinstalled after painting is complete, properly adjusted, tested and left in perfect working condition.

C. After each lock has been reinstalled, the installer shall seal its keys in one of the supplied envelopes. The keys shall be delivered to the owner or hardware supplier.

D. Prior to completion of the job, determine that all closers are in proper adjustment. No closer shall complete its full closing cycle in less than 4 to 6 seconds and there shall be no abrupt change in speed between the "sweep" and "latch speeds. All knobs, levers, and latch bolts shall be free from binding. Turn all wrenches and adjusting tools, as provided with the hardware, to the owner.

E. Hardware applied to wood labeled doors shall be fastened with thru-bolts and nuts.

F. Thresholds shall be set in a bed of mastic.

PART 4 HARDWARE GROUPS AND SUFFIXES

A. The following schedule of hardware groups shall be considered a guide only and the supplier is cautioned to refer general conditions, special conditions, and the preamble to this section. It shall be the hardware suppliers responsibility to furnish all required hardware.

B. Refer to the door schedule for hardware group required for each opening.

PART 1 GENERAL**1.1 SECTION INCLUDES**

- A. Insulating glass units.
- B. Glazing units.
- C. Glazing compounds and accessories.

1.2 RELATED REQUIREMENTS

- A. Section 07 2500 - Weather Barriers.

1.3 REFERENCE STANDARDS

- A. 16 CFR 1201 - Safety Standard for Architectural Glazing Materials; current edition.
- B. ANSI Z97.1 - American National Standard for Safety Glazing Materials Used in Buildings, Safety Performance Specifications and Methods of Test; 2010.
- C. ASTM C864 - Standard Specification for Dense Elastomeric Compression Seal Gaskets, Setting Blocks, and Spacers; 2015.
- D. ASTM C1036 - Standard Specification for Flat Glass; 2011.
- E. ASTM C1048 - Standard Specification for Heat-Strengthened and Fully Tempered Flat Glass; 2012.
- F. ASTM C1193 - Standard Guide for Use of Joint Sealants; 2016.
- G. ASTM C1376 - Standard Specification for Pyrolytic and Vacuum Deposition Coatings on Flat Glass; 2015.
- H. ASTM E1300 - Standard Practice for Determining Load Resistance of Glass in Buildings; 2016.
- I. ASTM E2190 - Standard Specification for Insulating Glass Unit Performance and Evaluation; 2010.
- J. GANA (GM) - GANA Glazing Manual; 2009.
- K. GANA (SM) - GANA Sealant Manual; 2008.
- L. GANA (LGRM) - Laminated Glazing Reference Manual; 2009.
- M. ICC (IBC) - International Building Code; 2015.
- N. IGMA TM-3000 - North American Glazing Guidelines for Sealed Insulating Glass Units for Commercial & Residential Use; 1990 (2004).
- O. ITS (DIR) - Directory of Listed Products; current edition.
- P. NFPA 252 - Standard Methods of Fire Tests of Door Assemblies; 2012.
- Q. NFPA 257 - Standard on Fire Test for Window and Glass Block Assemblies; 2012.
- R. NFRC 100 - Procedure for Determining Fenestration Product U-factors; 2014.
- S. NFRC 200 - Procedure for Determining Fenestration Product Solar Heat Gain Coefficient and Visible Transmittance at Normal Incidence; 2014.
- T. NFRC 300 - Test Method for Determining the Solar Optical Properties of Glazing Materials and Systems; 2014.
- U. UL (DIR) - Online Certifications Directory; current listings at database.ul.com.
- V. UL 9 - Standard for Fire Tests of Window Assemblies; Current Edition, Including All Revisions.
- W. UL 10B - Standard for Fire Tests of Door Assemblies; Current Edition, Including All Revisions.
- X. UL 10C - Standard for Positive Pressure Fire Tests of Door Assemblies; Current Edition, Including All Revisions.

1.4 SUBMITTALS

- A. See Section 01 3000 - Administrative Requirements, for submittal procedures.
- B. Product Data on Insulating Glass Unit and Glazing Unit Glazing Types: Provide structural, physical and environmental characteristics, size limitations, special handling and installation requirements.
- C. Product Data on Glazing Compounds and Accessories: Provide chemical, functional, and environmental characteristics, limitations, special application requirements. Identify available colors.
- D. Warranty Documentation: Submit manufacturer warranty and ensure that forms have been completed in Owner's name and registered with manufacturer.

1.5 QUALITY ASSURANCE

- A. Perform Work in accordance with GANA (GM), GANA (SM), GANA (LGRM), and IGMA TM-3000 for glazing installation methods.
- B. Installer Qualifications: Company specializing in performing work of the type specified and with at least three years documented experience.

1.6 FIELD CONDITIONS

- A. Do not install glazing when ambient temperature is less than 40 degrees F (4 degrees C).
- B. Maintain minimum ambient temperature before, during and 24 hours after installation of glazing compounds.

1.7 WARRANTY

- A. See Section 01 7800 - Closeout Submittals, for additional warranty requirements.
- B. Insulating Glass Units: Provide a five (5) year manufacturer warranty to include coverage for seal failure, interpane dusting or misting, including replacement of failed units.

PART 2 PRODUCTS

2.1 MANUFACTURERS

A. Float Glass Manufacturers:

1. Cardinal Glass Industries: www.cardinalcorp.com.
2. Guardian Industries Corp: www.sunguardglass.com.
3. Pilkington North America Inc: www.pilkington.com/na.
4. PPG Industries, Inc: www.ppgideascales.com.
5. Substitutions: Refer to Section 01 6000 - Product Requirements.

2.2 PERFORMANCE REQUIREMENTS - EXTERIOR GLAZING ASSEMBLIES

A. Provide type and thickness of exterior glazing assemblies to support assembly dead loads, and to withstand live loads caused by positive and negative wind pressure acting normal to plane of glass.

1. Design Pressure: Calculated in accordance with applicable codes.
2. Comply with ASTM E1300 for design load resistance of glass type, thickness, dimensions, and maximum lateral deflection of supported glass.
3. Provide glass edge support system sufficiently stiff to limit the lateral deflection of supported glass edges to less than 1/175 of their lengths under specified design load.
4. Glass thicknesses listed are minimum.

B. Vapor Retarder and Air Barrier Seals: Provide completed assemblies that maintain continuity of building enclosure vapor retarder and air barrier.

1. In conjunction with vapor retarder and joint sealer materials described in other sections.
 - a. Refer to Section 07 2500.
2. To utilize the inner pane of multiple pane insulating glass units for the continuity of the vapor retarder and air barrier seal.
3. To maintain a continuous vapor retarder and air barrier throughout the glazed assembly from glass pane to heel bead of glazing sealant.

C. Thermal and Optical Performance: Provide glass products with performance properties as indicated. Performance properties are in accordance with manufacturer's published data as determined with the following procedures and/or test methods:

1. Center of Glass U-Value: Comply with NFRC 100 using Lawrence Berkeley National Laboratory (LBNL) WINDOW computer program.
2. Center of Glass Solar Heat Gain Coefficient (SHGC): Comply with NFRC 200 using Lawrence Berkeley National Laboratory (LBNL) WINDOW computer program.
3. Solar Optical Properties: Comply with NFRC 300 test method.

2.3 GLASS MATERIALS

A. Float Glass: Provide float glass based glazing unless noted otherwise.

1. Annealed Type: ASTM C1036, Type I - Transparent Flat, Class 1 - Clear, Quality-Q3.
2. Heat-Strengthened and Fully Tempered Types: ASTM C1048, Kind HS and FT.
3. Fully Tempered Safety Glass: Complies with ANSI Z97.1 and 16 CFR 1201 criteria.
4. Tinted Type: ASTM C1036, Class 2 - Tinted, Quality-Q3, color and performance characteristics as indicated.
5. Thicknesses: As indicated; provide greater thickness as required for exterior glazing wind load design.

2.4 INSULATING GLASS UNITS

A. Manufacturers:

1. Cardinal Glass Industries: www.cardinalcorp.com.
2. Guardian Industries Corp: www.sunguardglass.com.
3. Pilkington North America Inc: www.pilkington.com/na.
4. PPG Industries, Inc: www.ppgideascales.com.
5. Viracon, Apogee Enterprises, Inc: www.viracon.com.
6. Substitutions: Refer to Section 01 6000 - Product Requirements.

B. Insulating Glass Units: Types as indicated.

1. Durability: Certified by an independent testing agency to comply with ASTM E2190.
2. Coated Glass: Comply with requirements of ASTM C1376 for pyrolytic (hard-coat) or magnetic sputter vapor deposition (soft-coat) type coatings on flat glass; coated vision glass, Kind CV; coated overhead glass, Kind CO; or coated spandrel glass, Kind CS.
3. Metal Edge Spacers: Aluminum, bent and soldered corners.
4. Spacer Color: Black.

5. Edge Seal:

- a. Dual-Sealed System: Provide polyisobutylene sealant as primary seal applied between spacer and glass panes, and silicone, polysulfide, or polyurethane sealant as secondary seal applied around perimeter.

6. Color: Black.

7. Purge interpane space with dry air, hermetically sealed.

C. Insulating Glass Units <INSUL GL-1>: Vision glass, double glazed.

1. Applications: Exterior glazing unless otherwise indicated.
2. Space between lites filled with argon.
3. Outboard Lite: Heat-strengthened float glass, 1/4 inch (6.4 mm) thick, minimum.
 - a. Tint: Clear.
 - b. Coating: Low-E (passive type), on #2 surface.
 - 1) Basis of Design:
 - (a) VNE1-63 by Viracon.
 - (b) PPG Industries: Solarban 70XL.
 - (c) Guardian Industries: SunGuard SNX 62/27.
4. Inboard Lite: Heat-strengthened float glass, 1/4 inch (6.4 mm) thick, minimum.
 - a. Tint: Clear.
5. Total Thickness: 1 inch (25.4 mm).
6. Thermal Transmittance (U-Value), Winter - Center of Glass: 0.25, nominal.
7. Visible Light Transmittance (VLT): 62 percent, nominal.
8. Solar Heat Gain Coefficient (SHGC): 28 percent, nominal.
9. Visible Light Reflectance, Outside: 10 percent, nominal.

D. Insulating Glass Units: Safety glazing.

1. Applications:
 - a. Glazed lites in exterior doors.
 - b. Glazed sidelights and panels next to doors.
 - c. Other locations required by applicable federal, state, and local codes and regulations.
 - d. Other locations where the material ID includes <INSUL TEMP ____>.
2. Space between lites filled with argon.
3. Glass Type: Same as other vision glazing except use fully tempered float glass for both outboard and inboard lites.
4. Total Thickness: 1 inch (25.4 mm).

2.5 GLAZING UNITS

A. Monolithic Interior Vision Glazing <GL-1>:

1. Applications: Interior glazing unless otherwise indicated.
2. Glass Type: Heat-strengthened float glass.
3. Tint: Clear.
4. Thickness: 1/4 inch (6.4 mm), nominal.

B. Fire-Protection-Rated Glazing <FR GL-DH45>, <FR GL-OH45>: Type, thickness, and configuration of glazing that contains flame, smoke, and does not block radiant heat, as required to achieve indicated fire-rating period of 45 minutes or less.

1. Applications:
 - a. Glazing in fire-rated door assembly.
 - b. Glazing in fire-rated window assembly.
 - c. Other locations as indicated on drawings.
2. Laminated Glass (Type G3) <FR LAM GL-1>
 - a. Provide at fire-rated locations as required by code.
 - b. Provide Pilkington Pyrodur in locations requiring maximum 20 minute fire rating.
 - c. Provide "FireLite NT" in locations requiring 45 or 90 minute fire rating.
 - d. Provide "Pilkinton Pyrostop" in locations with greater than 25% of glazed wall area.
3. Glass Type: Safety ceramic glass.
4. Provide products listed by ITS (DIR) or UL (DIR) and approved by authorities having jurisdiction.
5. Safety Glazing Certification: 16 CFR 1201 Category II.
6. Glazing Method: As required for fire rating.
7. Fire-Rating Period: As indicated on drawings.

8. Markings for Fire-Protection-Rated Glazing Assemblies: Provide permanent markings on fire-protection-rated glazing in compliance with ICC (IBC), local building code, and authorities having jurisdiction
- "D" - meets fire door assembly criteria of NFPA 252, UL 10B, or UL 10C fire test standards.
 - "OH" - meets fire window assembly criteria including hose stream test of NFPA 257, or UL 9 fire test standards.
 - "H" - meets fire door assembly hose stream test of NFPA 252, UL 10B, or UL 10C fire tests standards.
 - "XXX" - placeholder that represents fire-rating period, in minutes.

9. Manufacturers:

- SAFTIFIRST, a division of O'Keeffe's Inc: www.safti.com/sle.
- Technical Glass Products: www.fireglass.com.
- Vetrotech Saint-Gobain North America: www.vetrotechusa.com.
- Substitutions: Refer to Section 01 6000 - Product Requirements.

C. Monolithic Safety Glazing: Non-fire-rated.

1. Applications:

- Glazed lites in doors, except fire doors.
- Glazed sidelights to doors, except in fire-rated walls and partitions.
- Other locations required by applicable federal, state, and local codes and regulations.
- Other locations indicated on drawings.
- Other locations where the material ID includes <TEMP GL-____>.

2. <TEMP GL-____> Glass Type: Fully tempered safety glass as specified.

3. Tint: Clear.

4. Thickness: 1/4 inch (6.4 mm), nominal.

2.6 GLAZING COMPOUNDS

A. Manufacturers:

- Bostik Inc: www.bostik-us.com.
- Dow Corning Corporation: www.dowcorning.com/construction.
- Momentive Performance Materials, Inc: www.momentive.com.
- Pecora Corporation: www.pecora.com.
- BASF Corporation: www.basf.com/us/en.html.
- Substitutions: Refer to Section 01 6000 - Product Requirements.

2.7 ACCESSORIES

A. Setting Blocks: Neoprene, with 80 to 90 Shore A durometer hardness; ASTM C864 Option II. Length of 0.1 inch for each square foot (25 mm for each square meter) of glazing or minimum 4 inch (100 mm) x width of glazing rabbet space minus 1/16 inch (1.5 mm) x height to suit glazing method and pane weight and area.

B. Spacer Shims: Neoprene, 50 to 60 Shore A durometer hardness; ASTM C864 Option II. Minimum 3 inch (75 mm) long x one half the height of the glazing stop x thickness to suit application, self adhesive on one face.

C. Glazing Splines: Resilient silicone extruded shape to suit glazing channel retaining slot; ASTM C864 Option II; color black.

PART 3 EXECUTION

3.1 VERIFICATION OF CONDITIONS

A. Verify that openings for glazing are correctly sized and within tolerances, including those for size, squareness, and offsets at corners.

B. Verify that surfaces of glazing channels or recesses are clean, free of obstructions that may impede moisture movement, weeps are clear, and support framing is ready to receive glazing system.

C. Verify that sealing between joints of glass framing members has been completed effectively.

D. Proceed with glazing system installation only after unsatisfactory conditions have been corrected.

3.02 PREPARATION

A. Clean contact surfaces with appropriate solvent and wipe dry within maximum of 24 hours before glazing. Remove coatings that are not tightly bonded to substrates.

B. Seal porous glazing channels or recesses with substrate compatible primer or sealer.

C. Prime surfaces scheduled to receive sealant where required for proper sealant adhesion.

3.3 INSTALLATION, GENERAL

- A. Install glazing in compliance with written instructions of glass, gaskets, and other glazing material manufacturers, unless more stringent requirements are indicated, including those in glazing referenced standards.
- B. Install glazing sealants in accordance with ASTM C1193, GANA (SM), and manufacturer's instructions.
- C. Do not exceed edge pressures around perimeter of glass lites as stipulated by glass manufacturer.
- D. Set glass lites of system with uniform pattern, draw, bow, and similar characteristics.
- E. Set glass lites in proper orientation so that coatings face exterior or interior as indicated.
- F. Prevent glass from contact with any contaminating substances that may be the result of construction operations such as, and not limited to the following; weld splatter, fire-safing, plastering, mortar droppings, etc.

3.4 INSTALLATION - DRY GLAZING METHOD (GASKET GLAZING)

- A. Application - Exterior and/or Interior Glazed: Set glazing infills from either the exterior or the interior of the building.
- B. Place setting blocks at 1/4 points with edge block no more than 6 inch (152 mm) from corners.
- C. Rest glazing on setting blocks and push against fixed stop with sufficient pressure on gasket to attain full contact.
- D. Install removable stops without displacing glazing gasket; exert pressure for full continuous contact.

3.5 CLEANING

- A. Remove excess glazing materials from finish surfaces immediately after application using solvents or cleaners recommended by manufacturers.
- B. Remove non-permanent labels immediately after glazing installation is complete.
- C. Clean glass and adjacent surfaces after sealants are fully cured.
- D. Clean glass on both exposed surfaces not more than 4 days prior to Date of Substantial Completion in accordance with glass manufacturer's written recommendations.

3.6 PROTECTION

- A. After installation, mark pane with an 'X' by using removable plastic tape or paste; do not mark heat absorbing or reflective glass units.
- B. Remove and replace glass that is maged during construction priod prior to Date of Substantial Completion.

- A. Verify ALL Interior Finishes with Interior Designer/ Owner.
 - 1. Rubber flooring material on stairwells by Interior Designer.
- B. THIS PROJECT IS PARTICIPATING IN IMPLEMENTING MINNESOTA HOUSING FINANCE AGENCY SUSTAINABLE HOUSING POLICIES, most notably the **MN Overlay to the Green Communities Criteria**, which can be referenced at www.greencommunitiesonline.org/minnesota. These include the required criteria as stated below as a minimum acceptable standard prior to approval.
- C. Specifications/cut sheets from Interior Designer shall be provided with final submittal.

Product Guidelines are provided by Owner below to match Phase 2.

DIVISION 4

MATERIAL ID	DESCRIPTION	MANUFACTURER	STYLE	COLOR	COMMENTS
BRICK-1	4" Face Brick	BrickCraft	Modular	Harvest Blend	Includes molded units
CMU-2	16x8 Rock Face CMU	Anchor Block	Rock Face	Tumbleweed	Singled side exterior at exposed foundation
CAST STN-1	Cast Stone	Sill Reading Rock	Rockcast	Charlotte Tan	Brick Capstone
	Culture stone				Fireplace

DIVISION 5

MATERIAL ID	DESCRIPTION	MANUFACTURER	STYLE	COLOR	COMMENTS
05 5913	Metal Juliette Balcony	Classic Industries	Alumadeck	Black	At sliding glass doors, not at grade

DIVISION 6

Or by AI's Ornamental Iron & Welding

A

MATERIAL ID	DESCRIPTION	MANUFACTURER	STYLE	COLOR	COMMENTS
WD BASE-1	Wood Baseboard	Lianga	Legacy	Honey	Units
WD BASE-2	Wood Baseboard	Prefinished			Lobby, Clubroom, Fitness
WD TRIM-1	Wood Trim	Lianga	Legacy	Honey	Units
WD TRIM-2	Wood Trim	Prefinished			Lobby, Clubroom, Fitness
WD PNLG-2	Wood Paneling	Prefinished			Lobby, Clubroom, Fitness

A

Sloped roof deck

Canopy deck

DIVISION 7

MATERIAL ID	DESCRIPTION	MANUFACTURER	STYLE	COLOR	COMMENTS
SHINGLE-1	Asphalt shingles	GAF	Timberline HD	Weather Wood	
SIDING-95	Vinyl lap siding	Certainteed	Wolverine	American Legend Savannah Wicker	4 1/2" dutch lap
SIDING-96	Vinyl shingle siding	Certainteed	Cedar Impressions	Hearthstone	Double 7" straight edge
SMF-1	metal trim, gutters/ds	EDCO	Steel Entex	Desert Tone	Paint downspouts in front of brick
SMF-2	Metal trim	EDCO	Steel Entex	Black	Main entry canopy
INSUL-1	Extruded polystyrene				Exterior walls
INSUL-2	Extruded polystyrene				Foundations walls
INSUL-20	Fiberglass batt insul, unfaced				
INSUL-34	Bulk fiberglass insul pneumatic placement				In attic
RF UNDLMT-5	Self-adhering ice/water shield				Roof edges, ridges and valleys
VPR RET-1	6 mil poly vapor retarder sheet				Exterior walls
VPR RET-2	10 mil poly reinforced vapor retarder				Under conc slab
FR STOP	Through penetration fire stopping				
WTR PRF-7	60 mil membrane waterproofing	W.R. Meadow	Mel-Rol		With Mel-Drain drainage system
SEALANT-1	Sealant				
RF VENT-2	Soffit vent	EDCO	Steel Entex	White	Canopy soffits
EPDM-2	60 mil epdm roofing self-adhered				Entry canopies

DIVISION 8

MATERIAL ID	DESCRIPTION	MANUFACTURER	STYLE	COLOR	COMMENTS
ALUM STOR-1	Aluminum framed storefront	Tubelite	Center Set	Black	Medium stile door
	Solid core doors		Public & unit entry doors w/ redi-Frame	w/match wood both sides	
	Hollow core doors	Sienna			Unit interior doors trim to match door
	Vinyl window	Thermo-tech	Classic Series	White	
	Vinyl sliding glass door	Thermo-tech	Slim Line	White	
	Overhead door	CHI Commercial	3216	TBD std color	Horizontal ribs
	Aluminum louvers	Airolite	Stationary	TBD std color	
ACC PNL-2	Attic access panel	Best Access Door	BA-PFI-GyP	White	Fire rated, insulated, drywall flange

DIVISION 9

MATERIAL ID	DESCRIPTION	MANUFACTURER	STYLE	COLOR	COMMENTS
ACT-1	24"X24" ceiling tile	USG Mars	ClimaPlus	White	Tegular, fine texture
CER TILE-10	12"x12" wall tile grout	Daltile	Continental Slate	Moroccan Brown	Restroom installation
CER TILE-20	12"x12" floor tile grout	Daltile	Continental Slate	Moroccan Brown	Restroom installation
CER TILE-21	12"x12" floor tile grout	Daltile	Continental Slate	Moroccan Brown	Best, stir entrance and elevator
RES PLNK-1	6x36 luxury vinyl plank	Armstrong	Vivero	Hickory Point	Units
RES PLNK-2	6x36 luxury vinyl plank	Armstrong	Vivero	Hickory Point	Club room
VNL SHT-1	Resilient vinyl flooring	Mannington	Benchmark	Kingsbridge	Unit Bath and utility
VCT-1	Vinyl composite tile	Armstrong	Standard	Excelon Coaster Greige	Elec, trash, utility
RB BASE-1	4" rubber base, cove	Johnsonite	Clay		Resilient tile areas
RB BASE-3	6" rubber base, toeless	Johnsonite	Brown		corridors, stairwells
CPT-1	Broadloom carpet	Mannington	Canopy II	Hickory (83163)	Lobby club and corridor accents
CPT-2	Broadloom carpet	Shaw	Capital III	Eminence	Public carpet
CPT-3	Broadloom carpet	Kinetex	Sprees	Shindig	Fitness room
	Kinetex Dart		Dash or Sprint		Fitness room accent
CPT-4	Broadloom carpet	Shaw	Capital III	Eminence	Units (could use old color instead of sheet vinyl in accessible units)
GYP BD-1	5/8" gyp - type x				
GYP BD-4	5/8" gyp - type c				
MET FURG-4	Resilient furring chan.				
PT-1	Paint Sherwin Williams Pure White	7005			
PT-2	Paint Sherwin Williams Gobi Desert				
PT-	Paint Sherwin Williams Pearly White				
PT-	Paint Sherwin Williams Moody Blue				
PT-3	Paint Sherwin Williams				
INSUL-80	Acoustical batt insul				
VNL NOS	Flexible stair nosing	Johnsonite	VIVCD-XXX		

RF - Rubber Flooring - Raised round for landing surfaces and grit tape inserts for treads
 FM - Reese Perfec Mat
 Aluminum Hinge

A

Ceilings
 Walls in units
 Common Areas & Community Room: Top of wall
 Common Areas & Community Room: Bottom of wall
 Exterior hollow metal frames
 Exterior mechanical metal
 Accent color to stair carpet

DIVISION 10

MATERIAL ID	DESCRIPTION	MANUFACTURER	STYLE	COLOR	COMMENTS
MAILBOX-1	Recessed front load	Florence	4C15D	Black 51	mailboxes, 3 w/ADA reach
WIRE SHLV-1	Wire storage shelves				
MIRROR-50	Frameless mirror				
FIREPLACE-1	Direct vent gas Heat & Glo	Mezzo	36	single sided Black trim	Loft forge front

DIVISION 11

MATERIAL ID	DESCRIPTION	MANUFACTURER	STYLE	COLOR	COMMENTS
FRIDGE-1	18.2 CF fridge	GE	GTE18ITHWW		1 bd units
FRIDGE-2	21.2 CR fridge	GE	GTE21GTHWW		2+ bd units
RANGE-1	30" electric range	GE	JB250DFWW		Type b units
RANGE-2	30" ADA elec. Range	GE	JB250DFWW		Type a units
RANGE HD-1	30" under cabinet hood	GE	JCX3300DJWW		Type a units
MICROWAVE-2	Countertop microwave	GE	JESI460DSWW		Type a units (opt A 1.4 CF)
MICROWAVE-3	Countertop microwave	GE	PEM31DFWW		Type a units (opt B 1.1CF)
DISHWASHER-1	Built-in dishwasher	GE	GSD3301KWW		Type b units
DISHWASHER-2	ADA dishwasher	GE	GLDT690JWW		Type a units
WASHER-1	4.2 CF capacity washer	GE	GTW485ASHWS		Type b units

090000 - INTERIOR FINISHES

DIVISION 11- continued from previous page

MATERIAL ID	DESCRIPTION	MANUFACTURER	STYLE	COLOR	COMMENTS
WASHER-2	3.9 CF front load washer	Frigidaire	FFFW5000QW		Type a units
DRYER-1	8.3 CF front load dryer	GE	GFD48ESSKWW		Type b units
DRYER-2	7.0 CF front load dryer	Frigidaire	FFQE5000QW		Type a units
	Playground equipment	Game time			Verify with Owner/Interior Designer
	Playground safety surfacing – rubber tile	Game time	GT IMPAX		Border: EPDM Orange FIELD: EPDM Brown

DIVISION 12

MATERIAL ID	DESCRIPTION	MANUFACTURER	STYLE	COLOR	COMMENTS
RES CASE-1	Residential casework	Advanta	Premier series	Mocha	Club room
RESS CASE-2	Residential casework	Advanta	Premier series	honey	Units
PLAM CTOP-1	Laminate countertops	Wilsonart	Milano	amber	Unit kitchens
SOLID SURF-20	Solid surface window sills	Central marble	Standard colors	965 white on white matt	
SSURF CTOP-21	Solid surface countertops	Central marble	Standard colors	965 white on white matt	Unit bathrooms
BLINDS-10	Vinyl horizontal miniblinds	Bali	Customizer	Almost White Gloss	Metal at unit windows
BLINDS-20	Vertical louver blinds	Graber	G-85	Tan Alum	at unit sliding doors and public windows
FLR MAT-1	Entrance floor mat	Resse	Enterprise	Perfec floor mat	
	Midnight carpet anodized clear				Rubber hinged with embedded anod alum frame

DIVISION 14

MATERIAL ID	DESCRIPTION	MANUFACTURER	STYLE	COLOR	COMMENTS
CHUTE	Trash chute	Chutes intl			30" diam chute
ELEV	Holeless hydraulic elec	3500 lbs schindler	330A	Dual Jack	Side front/rear openings plastic lam side and rear walls, ss front and ceiling

INSERT CUT SHEETS from Interior Designer

**INTERIOR SIGNAGE
COLOR SELECTIONS:**

**Body of Interior Signs =
3X1-509
Bahama Blue**

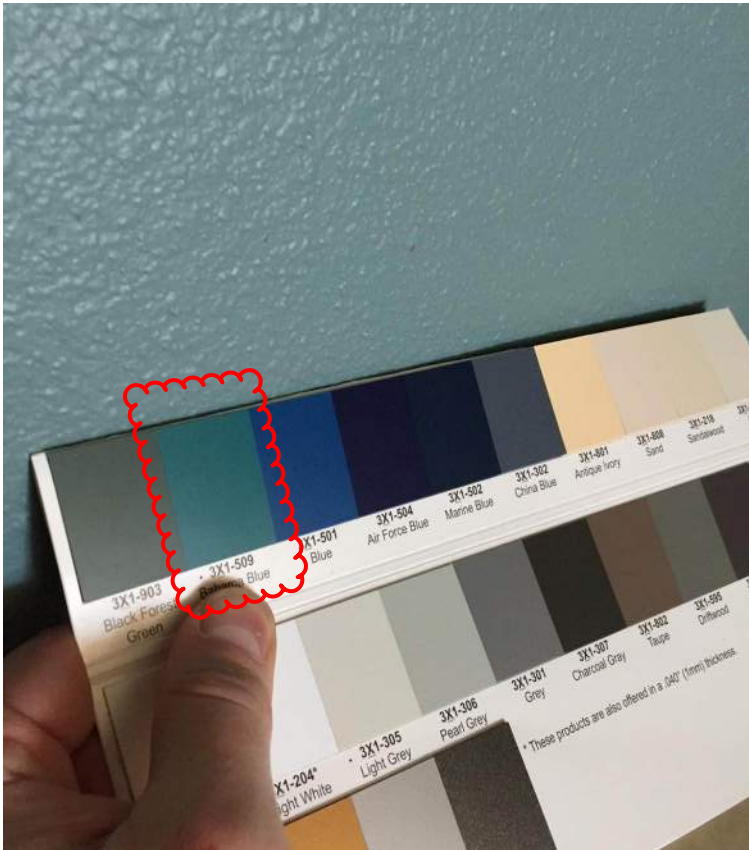

**Lettering, Numbers, Etc.=
3X1-201
White**





Toll-Free: 1-877-242-8821 Local: 952-895-8811 Fax: 952-894-0453



HOME PEDIMAT® PEDIGRID® PEDITRED® FAQs MAT MAINTENANCE OTHER MATS



Reese Perfec Mat Aluminum Hinge

Perfec™ Aluminum Hinge mats feature durability, effective cleaning and convenience - all in a product that rolls back for easy maintenance. Rails and hinges are manufactured of quality 6063-T52 aluminum with slotted holes for maximum drainage. Designed for both new construction and remodel this metal entrance mat can be customized with different carpet, vinyl, tape abrasive, and exterior brush inserts. The rails are spaced 2" on center and connected with aluminum hinges for trapping and retaining dirt and moisture. Rated at 300 lbs per wheel load this metal entrance mat can accomodate high-traffic for commercial applications.



Weight Capacity: 300 lbs per wheel load



Weight per Square Foot: 1.9 lbs



Depth: 3/8"



Roll-up Capability: Yes



Rail Spacing: 2.0" on Center



Warranty: 2 years



Select Size: Mats are custom made for replacement/remodeling of existing mats or new construction.



Select Finish: Choose from either natural aluminum (mill) or clear, light bronze, medium bronze, dark bronze, black, or gold anodized.



Select Insert Type and Color: Choose from Nylon or Exterior Carpet, Abrasive Tape, Vinyl, or Serrated.

Perfec Mat Nylon Carpet Insert Color Choices

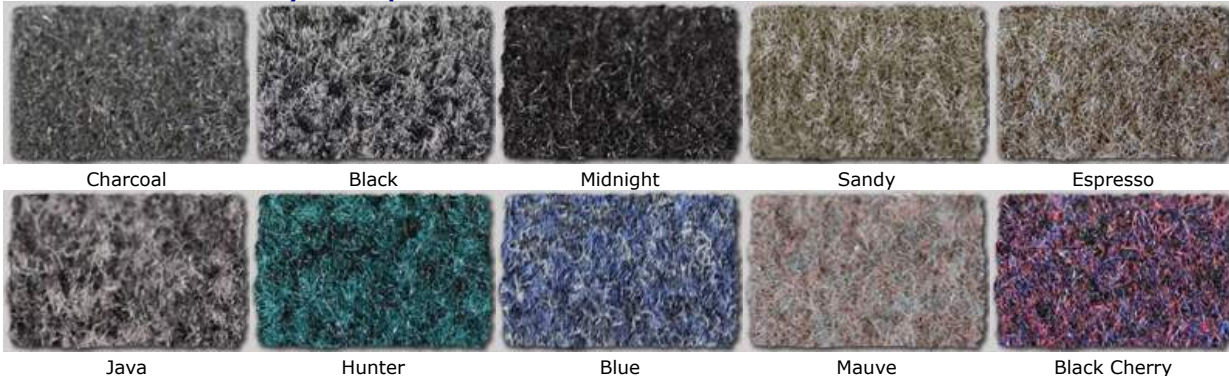

Perfect Mat Exterior Brush Carpet Insert Color Choices



Gray

Jet Black

Brown

Perfect Mat Abrasive Tape Insert Color Choices



Gray

Black

Red

Brown

Perfect Mat Vinyl Tread Insert Color Choices

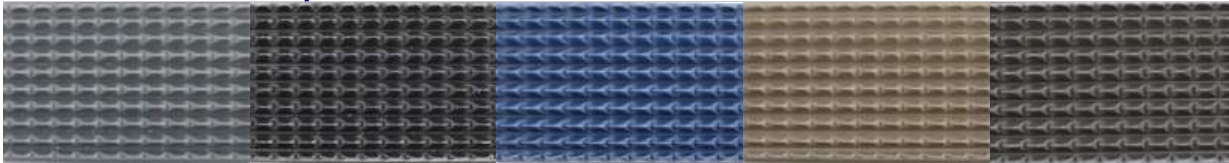

Gray

Black

Blue

Beige

Brown

4 Select Frame: Choose Frame Type for Application

Reese Perfect Mat Frame Options

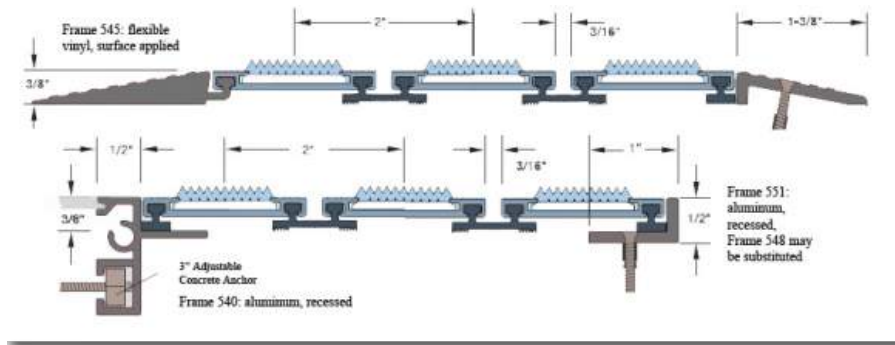

Samples provided upon request

Information or Quote Request

PEDIMAT
TreadLine T1
Pedimat M1
Pedimat M2
Pedimat Information

PEDIGRID
Pedigrig G1
Pedigrig SA G8
Pedigrig Information

PEDITRED
PediTred LP G3
PediTred G4
PediTred SA G7
PediTred Information

GRIDLINE
Gridline G6
Gridline G6 Information

CONTACT INFO:

Address:

13220 Willow Lane Circle
Burnsville, MN 55337

Phone: 877-242-8821

Email: ronick@ronick.com

Sitemap

© Ronick Entrance Matting Systems.
All Rights Reserved.

Pedimat, PediTred, Pedigrig & Gridline are the registered names and property of Construction Specialties, Inc.

Striping Solutions for the Visually Impaired.

Our efforts in floor safety have evolved into the industry's largest selection of solutions for the visually impaired. These include stair treads and nosings in many colors, along with Grit Tape and contrasting rubber inserts in solid colors, Prima® Marbleized™ and photoluminescent options.

A = Essentials Color Palette

B = Accents Color Palette

C = ColorMatch

▲ = Can be specially ordered in Prima® Marbleized™ and Prima Olio® colorways. Visit tarkettna.com. See page 49 for details. Minimums may apply.

W = sizes/available lengths 3', 3.5', 4', 6', 8', 12'

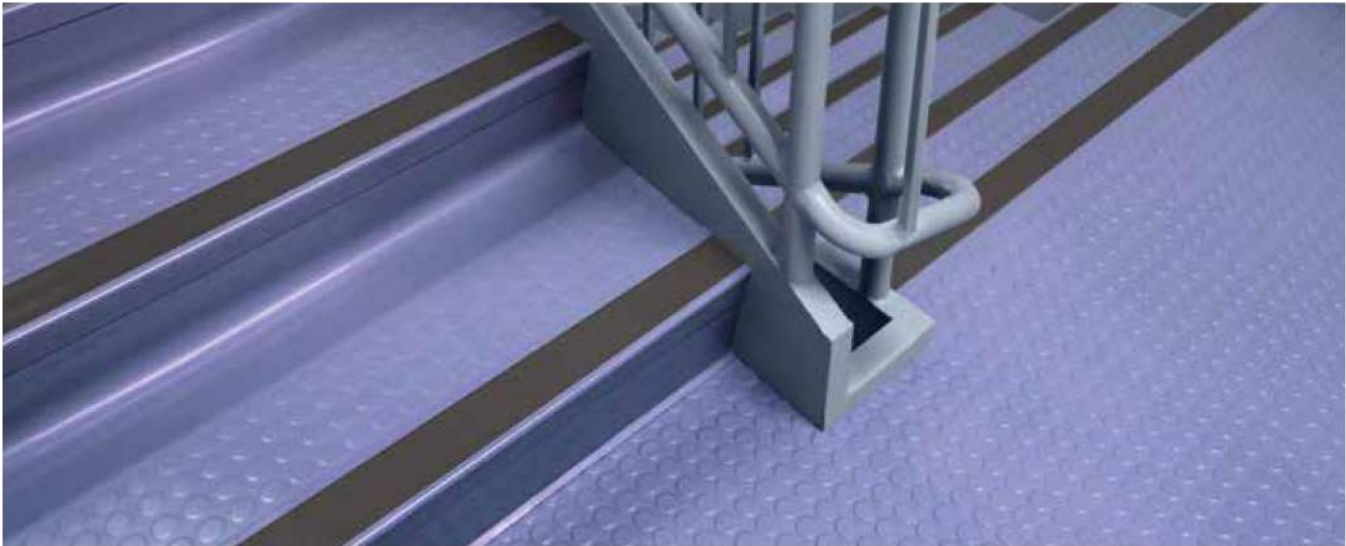

VISUALLY IMPAIRED COLOR SOLUTIONS

GRIT TAPE COLOR

	Black
	Brown
	Grey
	Tan
	Yellow
	White

Black: Grit Tape contrasts with colors 01, 05, 12, 21, 24, 27, 28, 29, 31, 32, 38, 41, 48, 55, 58, 59, 62, 71, 75, 84, 106, 121, 129, 135, 138, 139, 150, 151, 163, 165, 166, 190, 192, 280, 281, 282, 289, 291, 293, 468, 470, 472, 476, 590, 591, 592, 593, AGM, BRL, BRM, CGL, CGM, CPM, WGL, WGM, LA2, LA3, LA5, LA6, LA8, LB4, LB6, LC8, LC1, LC2, LC3, LC4, LC5, LD6, LD7, LD1, LD2, LD4, LD5, LD7, LE1, LE3, LE7, LF2, LF6, LF8, LF9, LG1, LG3, LG8, LH3, LH7, LJ1, LJ2, LJ3, LJ5, LJ7, LJ8, LJ9, LK1, TB5, TB6

Brown: 09, 11, 19, 22, 33, 34, 42, 45, 49, 60, 68, 80, 111, 112, 130, 146, 285, 286, 469, 473, 474, 475, LA1, LA9, LB2, LB3, LC9, LD8, LD9, LE2, LE4, LE5, LE8, LE9, LF1, LF3, LF4, LG4, LG7, LG9, LH2, LH4

Grey: 15, 18, 20, 40, 72, 73, 85, 86, 92, 148, 162, 168, 294, 471, CGD, LB5, LB8, LB9, LD3, LE6, LF5, LG2, LG6, LH7, LH9, TB6, WGD

Tan: 44, 47, 63, 76, 101, 113, 132, 149, 167, 283, 284, 287, BRD, CPD, LA7, LB1, LD6

Yellow: 70, LB7, LF7, LJ4

White: Grit Tape available by special order

Photoluminescent: Tape available

SOLID COLOR RUBBER INSERT

	40 Black
	47 Brown
	55 Silver Grey
	49 Beige
	75 Lemon
	85 Burgundy

Black 40: Insert contrasts with colors 01, 05, 12, 21, 24, 27, 28, 29, 31, 32, 38, 41, 48, 55, 58, 59, 62, 71, 75, 84, 106, 121, 129, 134, 135, 138, 139, 150, 151, 163, 165, 166, 190, 192, 280, 281, 282, 289, 291, 293, 468, 470, 472, 476, 486, 590, 591, 592, 593, AGM, BRL, BRM, CGL, CGM, CPM, WGL, WGM, LA2, LA3, LA5, LA6, LA8, LB4, LB6, LC8, LC1, LC2, LC3, LC4, LC5, LC6, LC7, LD1, LD2, LD4, LD5, LD7, LE1, LE3, LE7, LF2, LF6, LF8, LF9, LG1, LG3, LG8, LH3, LH7, LJ1, LJ2, LJ3, LJ5, LJ7, LJ8, LJ9, LK1, TB5, TB6

47 Brown: 09, 11, 19, 22, 33, 34, 42, 45, 49, 68, 80, 111, 112, 130, 146, 285, 286, 469, 473, 474, 475, LA1, LA9, LB2, LB3, LC9, LD8, LD9, LE2, LE4, LE5, LE8, LE9, LF1, LF3, LF4, LG4, LG7, LG9, LH2, LH4

55 Silver Grey: 15, 18, 20, 40, 72, 73, 85, 86, 92, 148, 162, 168, 294, 471, CGD, LB5, LB8, LB9, LD3, LE6, LF5, LG2, LG6, LH7, LH9, TB6, WGD

49 Beige: 44, 47, 63, 76, 101, 113, 132, 149, 167, 283, 284, 287, BRD, CPD, LA7, LB1, LD6

75 Lemon: 70, LB7, LF7, LJ4

85 Burgundy: Insert contrasts with color 60

RUBBER LANDING TILE FOR USE WITH VINYL AND RUBBER STAIR TREADS

All tiles available in 24" x 24". Smooth is also available in 12" x 12".



A **B** **▲** Smooth (C)



A **B** Diamond (CN)

All tile textures can be used as landing tile.

Angle Fit Rubber Tread Risers without Integrated Risers

Standard Rubber Stair Treads

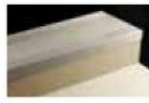

Bamboo Tread (BMNT)
S ▲ ★ X

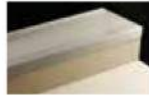

Cubis Tread (CUBT)
S ▲ ★ X

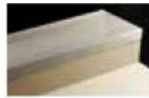
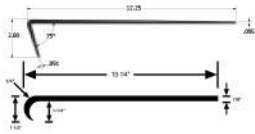

Fast Lane Tread (CFLNT)
S ▲ ★ X



Raised Round Tread (RNRD)
S ▲ ★ Y



Raised Square Tread (RNSQ)
S ▲ X



Hammered Tread (HMNT) 12 1/4" deep (HMNTD) 14" deep
S M ▲ Z

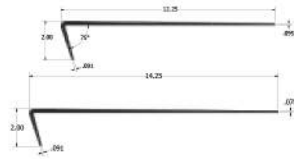

Service Weight Smooth Tread (SN)
S X



Diamond Tread (CNN)
S ▲ X

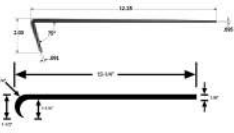

Rice Paper Tread (FRPANT)
S ▲ X



Service Weight Safe-T-Grip Tread (SAN)
S X



Standard Rubber Stair Treads for the Visually Impaired



Bamboo Tread Visually Impaired (VIMNT)
S ▲ + X



Cubis Tread Visually Impaired (VICUBT)
S ▲ + X



Fast Lane Tread Visually Impaired (VICLNT)
S ▲ + X



Raised Round Tread without Riser Visually Impaired (VIRNRD)
S ▲ ★ + Y



Raised Square Tread without Riser Visually Impaired (VIRSQ)
S ▲ + X



Hammered Tread without Riser Visually Impaired (VIHMNT) 12 1/4" deep (VIHMNTD) 14" deep
S M ▲ + Z



Service Weight Smooth Tread Visually Impaired (VISN)
S + X



Diamond Tread Visually Impaired (VICNN)
S ▲ + X



Rice Paper Tread Visually Impaired (VIFRPANT)
S ▲ + X



ICC ECR-1000 Certified

Angle Fit Rubber Tread Risers without Integrated Risers

Angle Fit Rubber Stair Treads

Visually Impaired Color Solutions +

Grit Tape Color



Black: Grit tape contrasts with colors 01, 12, 21, 24, 27, 28, 29, 31, 32, 38, 41, 48, 55, 58, 59, 62, 71, 84, 106, 121, 129, 150, 151, 163, 190, 192, 280, 281, 282, 293, AGM, BRL, BRM, CGL, CGM, CPM, WGL, WGM, LA2, LA3, LA5, LA6, LA8, LB4, LB6, LC8, LC1, LC2, LC3, LC4, LC5, LC6, LC7, LD1, LD2, LD4, LD5, LD7, LE1, LE3, LE7, LE2, LF6, LF8, LF9, LG1, LG3, LG8, LH3, LH7, LJ1, LJ2, LJ3, LJ5, LJ7, LJ8, LJ9, LK1, TB6, TG2, TG3, TG5, TG6, TG7, TG8, TH1

Brown: 09, 11, 22, 33, 34, 42, 45, 49, 68, 80, 130, 469, LA1, LA9, LB2, LB3, LC9, LD8, LD9, LE2, LE4, LE5, LE8, LE9, LF1, LF3, LF4, LG4, LG7, LG9, LH2, LH4

Grey: 15, 18, 20, 40, 72, 73, 85, 86, 92, 162, 168, CGD, LB5, LB8, LB9, LD3, LE6, LF5, LG2, LG6, LH7, LH9, TG1, TG4, WGD

Tan: 47, 63, 76, 101, 113, 132, 149, 167, 284, 548, 725, BRD, CPD, LA7, LB1, LD6, TG9, TH2, TH3

Yellow: 70, LB7, LF7, LJ4

White Grit Tape available by special order
Photoluminescent Tape available

Solid Color Rubber Insert



40 Black: Insert contrasts with colors 01, 12, 21, 24, 27, 28, 29, 31, 32, 38, 41, 48, 55, 58, 59, 62, 71, 84, 106, 121, 129, 134, 150, 151, 163, 190, 192, 280, 281, 282, 293, 486, AGM, BRL, BRM, CGL, CGM, CPM, WGL, WGM, LA2, LA3, LA5, LA6, LA8, LB4, LB6, LC8, LC1, LC2, LC3, LC4, LC5, LC6, LC7, LD1, LD2, LD4, LD5, LD7, LE1, LE3, LE7, LE2, LF6, LF8, LF9, LG1, LG3, LG8, LH3, LH7, LJ1, LJ2, LJ3, LJ5, LJ7, LJ8, LJ9, LK1, TB6, TG2, TG3, TG5, TG6, TG7, TG8, TH1

47 Brown: 09, 11, 22, 33, 34, 42, 45, 49, 68, 80, 130, 469, LA1, LA9, LB2, LB3, LC9, LD8, LD9, LE2, LE4, LE5, LE8, LE9, LF1, LF3, LF4, LG4, LG7, LG9, LH2, LH4

55 Silver Grey: 15, 18, 20, 40, 72, 73, 85, 86, 92, 162, 168, CGD, LB5, LB8, LB9, LD3, LE6, LF5, LG2, LG6, LH7, LH9, TG1, TG4, WGD

49 Beige: 47, 63, 76, 101, 113, 132, 149, 167, 284, 548, 725, BRD, CPD, LA7, LB1, LD6, TG9, TH2, TH3

Landing Tile

All tiles available in 24" x 24". Smooth is also available in 12" x 12".

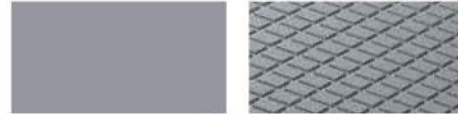

Smooth (C) S ▲ Diamond (CN)

All tile textures can be used as landing tile.

COLOR PALETTE AVAILABILITY

- S** = Available in Solid Color Palette
- = MicroTone™ Speckled colorways
- M** = Can be ordered in Metallurgy colorways
- ▲** = Can be special ordered in Prima® Marbleized and Prima Olio® colorways. Visit tarketna.com. Minimums may apply
- ★** = Can be special ordered in Speckled colorways.

Stair Tread Insert Color Combinations

+ = See chart above for recommended contrasting color combinations.

Sizes/Available Lengths

- X** = 3^A, 3.5^A, 4', 4.5', 5', 6'
- Y** = 3^A, 3.5^A, 4', 4.5', 5', 6', 7', 8'
- Z** = 3^A, 3.5^A, 4', 4.5', 5', 6', 7', 8', 9'

▲ Denotes special order.

Enlarged Textures Below

Indoor Air Quality

Low Emitting materials EQ 4.3
FloorScore™ certified and meets CA 01350

Angle Fit Rubber Stair Treads Textures



Angle Fit Rubber Tread Risers without Integrated Risers



Angle Fit Rubber Tread Risers without Integrated Risers



TB1 Peppercorn 282 Vaporize 276 Mystical 264 Grounded



151 Iguana TH1 Glenhaven 190 Greege TB2 Boxwood



59 Heather Green 293 Peacock 73 Palm Leaf 72 Harbour



41 Sea Breeze 192 Tidewater 84 Blue Jeans 70 Bluest



106 Skinny Dip 83 Midnight TH3 Inkwell TA9 Indigo



TB4 Grapest TG9 Poetry Plum 162 Sovereign 14 Tropical Storm



33 Adobe Peach 113 Chestnutty TA7 Rusty Nail TH2 Blue Intensity



TG7 Canary 62 Tangerine Tango TG8 Spicy Chip TB6 Flame



284 Ganache 15 Cabernet 163 Salsa



2525 Co. Rd. 24 • ST. CLOUD, MN 56301 • PHONE: 320/252-2314

Stainless Steel Appliance List

Date 1/11/2018
 Direct: 320.241.2176
 Email: mloesch@karlsinc.com

Project: Bottineau Ridge II
 TBA 11875 80th Ave N
 Maple Grove, MN 55311

Quantity	Units	Model #	Description E-STAR Stainless Steel Appliances
47	Std.	FFHT2032TS	21 Cu Ft E-Star , 2 Glass Shelves; Full Width Freezer Shelf
4	ADA & CR	FFHT1821TS	Refer.; ADA; E-Star; Refer. 18 Cu. Ft. Glass Shelves
47	Std.	FFEF3054TS	Elec. Self Clean Range; Smooth Top; ES300 Clock & Timer; 2-9" & 2-6" Burners
4	ADA & CR	FFED3026TS	ADA 30" Drop-In Elec. Range w/Front CONTROLS, Self Clean; Smooth Top, W/clock & wi
51	ALL	PL4000	4', 4 Wire Range Cords
51	ALL	FHWC3025MS	30" Convertible Hood; 2 Speed fan w/light
51	ALL	FFMO1611LS	1.6 CU. FT. Counter Top Microwave
47	Std.	FFCD2413US	D/W; Energy Star, Full Electronic Controls, Tall Tub 1 Piece Door, 5 Level Wash, Precision
4	ADA & CR	FDB2410HIC	ADA Compliant Dishwasher; E-STAR, 5 CYC, 4 OPT, 4 CONSOLE, SS TUB, NYLON RACI
51	ALL	MISCC26	Dishwasher Cord 3 wire
47	Std.	WTW7000DW	27", E-Star Top Load Washer ; 4.8 CU FT
47	Std.	WED7000DW	Elec. Dryer 29", 7.0 CU FT, 4 TEMPS, ACCUDRY, EOC, WRINKLE SHIELD 40, 3 KNOB
3	ADA	EFLW317TIW	Front Load Washer, ADA - E-Star; 4.3 cu ft
3	ADA	EFDE317TIW	27" Electric Dryer with 8.0 cu. ft. Capacity
50	ALL	MISC3805FFSS	Stainless Steel Supply Hose; 5' Two per Pack
50	ALL	PT600L	6 ft., 4 Prong Dryer Cord
94	ALL	FFTA1233U2	12,000 BTU, 230 VOLT Energy Star
94	ALL	5304514430	A/C Sleeves (No Assembly Required)
94	ALL	21206	6"A/C Inside Cover
51	ALL	EP300108	Grease Shields 24' by 30" (Installed)

FFTA1233U2



SIGNATURE FEATURES

Effortless™ Remote Temperature Control

Remote control thermostat precisely maintains preset room temperature, so you can remain comfortable at all times.

Programmable 24-Hour On/Off Timer

With the 24-Hour On/Off Timer, you can ensure your home will be cool and comfortable when you want it to be without having to worry about running up your utility bills. The built-in timer allows you to preset the unit to turn on and off in half-hour increments.

Energy Saver Mode

Reduce your utility bills in this mode. It cools similarly to central air, with the unit turning on and off at different intervals to ensure the room temperature stays at the set temperature.

Multi-Speed Fan

Features three different fan speeds, for more cooling flexibility.

HOME COMFORT

THROUGH-THE-WALL AIR CONDITIONER

PRODUCT DIMENSIONS

Height	14-1/2"
Width	24"
Depth	20-5/8"

MORE EASY-TO-USE FEATURES

Sleep Mode

With Sleep Mode, the temperature gradually increases a few degrees over the evening, saving energy and creating a comfortable environment during the evening hours.

Remote Control

Offers you the flexibility to control the temperature and fan speed from anywhere in the room.

Effortless™ Clean Filter

Our antibacterial filter reduces bacteria, room odors and other airborne particles for a healthier, more comfortable environment.

Power Cord

Comes with an extra long three-prong cord — makes extension cords unnecessary.

Effortless™ Restart

Automatically resumes operating at its previous settings when power is restored to your unit.

Clean Filter Alert

Alert notifies you when your filter needs to be cleaned so you don't have to keep track of it yourself.

Ready-Select® Controls

Easily select options with the touch of a button.

CERTIFICATIONS

ENERGY STAR®



PERFORMANCE	BTUs
Cool	12,000/11,700

THROUGH-THE-WALL AIR CONDITIONER

PERFORMANCE

BTU (Cool)	12,000/11,700
Dehumidification (Pints/Hour)	3.4
Cool Area (Up To Sq. Ft.)	550
Combined Energy Efficiency Ratio	10.5
Energy Efficiency Ratio	10.5

ELECTRICAL

Volts	230/208
Amps (Cool)	5.2/5.6
Watts (Cool)	1,140/1,110
Length of Power Cord (Min./Max.)	5.5'/6'
Plug Type (NEMA)	LCDI (6-15P)

FEATURES

Electronic Controls	Ready-Select® Controls
Fan Speeds (Cool/Fan)	3/3
Low Voltage Start-Up	Yes
Auto Cool Function	Yes
Energy Saver Mode	Yes
Sleep Mode	Yes
Filter Check	Yes
24-Hour On/Off Timer	Yes
Clean Air Ionizer	
Remote Control	Full-Function Remote Thermostat
Air CFM (High/Med/Low)	310/282/253
Air Direction Control	6-Way
Fresh Air/Exhaust Vent/Closed	No/No/Yes
Filter Type	Antibacterial Mesh
Filter Access	Slide-Out
Slide-Out Chassis	
Warranty ¹	Yes

OPTIONAL ACCESSORIES

Through-The-Wall 18" Sleeve Kit	PN# 5304514430
Trim Kit (for larger existing sleeve)	Included
Architectural-Style Exterior Louvered Grille	PN# 5304515640

CERTIFICATIONS

ENERGY STAR®	Yes
Performance	AHAM

SPECIFICATIONS

Refrigerant	R410a
Shipping Weight (Approx.)	99 Lbs.

¹Warranty five (5) years full parts and labor.

PRODUCT DIMENSIONS

A - Height	14-1/2"
B - Width	24"
C - Depth	20-5/8"
D - Max. Wall Thickness	18"

SLEEVE CUTOUT DIMENSIONS

Height	15-5/8"
Width	25-15/16"

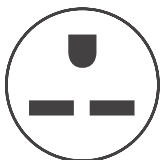
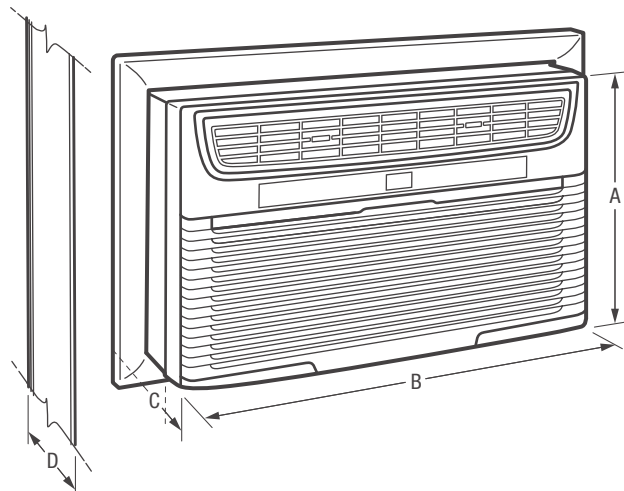

Plug Type (NEMA)
6-15P



Note: For planning purposes only. Always consult local and national electric, gas and plumbing codes. Refer to Product Installation Guide for detailed installation instructions on the web at frigidaire.com.

Specifications subject to change. Accessories information available on the web at frigidaire.com

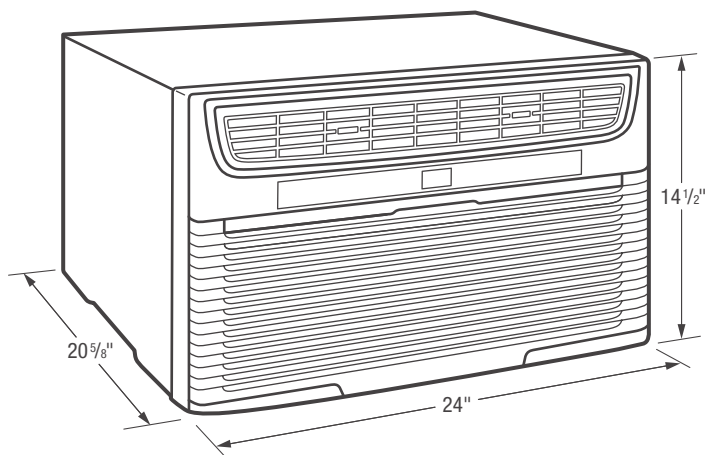

Through-The-Wall 18" Sleeve Kit
(PN # 5304514430)

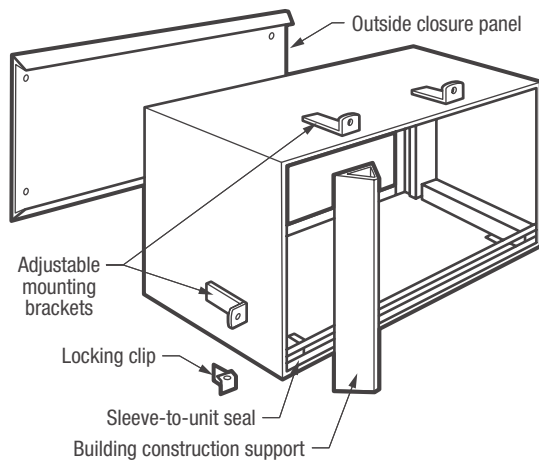

Through-The-Wall Installation

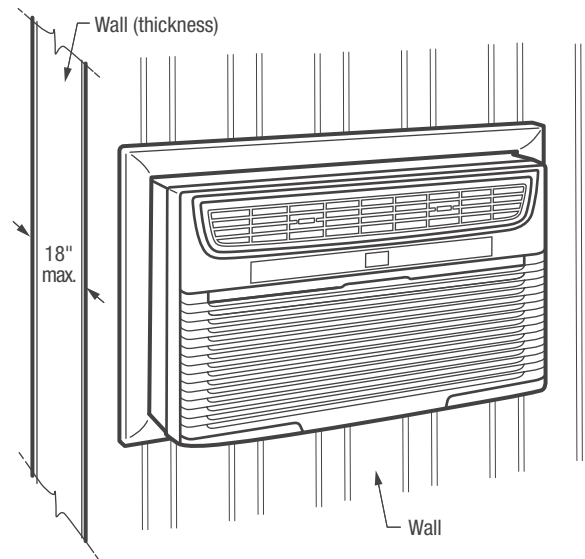

Plug Type (NEMA)
6-15P

INSTALLATION SPECIFICATIONS

- Product Shipping Weight (approx.) - 99 Lbs.
- Single phase 3-wire cable, 230/208 Volt, 60 Hertz AC only electrical supply with ground required on separate circuit fused on both sides of line.
- Voltage Rating - 230V/208V/60 Hz
- Amps @ 230/208 Volts = 5.2/5.6 Amps
- Recommended Circuit Breaker - 15 Amps
- Unit equipped with 230/208V 3-wire power supply cord, NEMA plug type 6-15P, approximately 72" long.
- Unit's increased performance characteristics result from two rear intakes. For unit to operate at maximum efficiency, carefully follow complete, detailed new or replacement installation instructions provided in Product Installation Guide on web.
- Unit requires rearward slope when installation is complete, to allow condensate to drain from rear of sleeve.

NEW INSTALLATION

- For new installation, Frigidaire® Through-The-W all 18" Sleeve Kit PN# 5304514430 available. Recommended for proper installation.
- Through-the-wall installation requires 18" maximum wall thickness.
- For energy-saving purposes, install unit in shady location, preferably a northern exposure; and do not block airflow inside with blinds, curtains or furniture; or outside with shrubs, enclosures or other buildings.

REPLACEMENT INSTALLATION

- When replacing existing air conditioner with new unit, refer to Product Installation Guide on web to identify existing wall-sleeve manufacturer and size compatibility. If proper installation and slope are suspect, then correct installation of Frigidaire® Through-The-Wall 18" Sleeve Kit PN# 5304514430 recommended.
- Use of existing wall sleeve to mount new unit requires original sleeve be in sound structural condition with rear grille that attaches securely, or rear flange that serves as stop for unit.
- Preferable installation option, for increased efficiency and possibility of drafts reduced, requires existing rear grille (*mounted to sleeve*) be replaced with new unit's rear air-directional louvered grille (*provided in accessory kit, shipped with unit*). Non-preferable installation option of directly mounting rear louvered grille to unit can be considered, requiring grille be mounted to unit prior to sleeve installation.
- Existing decorative exterior grille may be left in place, provided that proper air-directional rear louvered grille is installed.
- For installation into larger existing sleeve, optional Trim Kit is included.

OPTIONAL ACCESSORIES

- Through-The-Wall 18" Sleeve Kit - (PN# 5304514430).
- Trim Kit (*for larger existing sleeve*) - Included.
- Architectural-Style Exterior Louvered Grille - (PN# 5304515640).

Note: For planning purposes only. Always consult local and national electric, gas and plumbing codes. Refer to Product Installation Guide for detailed installation instructions on the web at frigidaire.com. Specifications subject to change. Accessories information available on the web at frigidaire.com



ELECTRIC FRONT LOAD DRYER

8.0 Cu. Ft.

EFDE317TIW

With IQ-Touch™ Controls



PRODUCT DIMENSIONS

Height	38"
Width	27"
Depth	31-5/8"

MORE EASY-TO-USE FEATURES

5 CYCLES TO CARE FOR EVERY FABRIC

Perfectly dry every item with tailored cycles for towels, delicates, and more.

FITS MORE ROOMS WITH REVERSIBLE DOOR

Enjoy easy loading no matter how your washer and dryer are configured.

OPTIONAL PEDESTALS AND STACKING KIT FOR MORE INSTALLATION OPTIONS

Raise your units with optional pedestal drawers that provide extra storage. Or use the optional stacking kit for convenient placement in small spaces.

Available in:



Island White
(IW)

*Based on manufacturer specifications among common 27" platforms.

**Eligibility based on product registration with Electrolux North America within 60 days of purchase. Products must have been purchased on or after July 1, 2013. See limited warranty for details. Limited time offer.

SIGNATURE FEATURES



KEEPS CLOTHES LOOKING THEIR BEST

Clothes are gently tumbled while moisture sensors detect when clothes are dry to prevent over-drying. Customizable options and cycles allow you to care for every fabric.



ENERGY STAR®-CERTIFIED

Rigorously tested to do more with less. Electrolux dryers meet strict criteria to guarantee high-quality energy efficient performance.



LARGEST CAPACITY DRYER

Dry more in each load. Our 8.0 cu.ft. dryers have the largest capacity for a standard 27" platform.¹



PLATINUM STAR® LIMITED WARRANTY

Our exclusive limited warranty that includes three year coverage on parts and one year on labor.²

ELECTRIC FRONT LOAD DRYER

EFDE317TIW



27" ELECTRIC FRONT LOAD DRYER

Capacity D.O.E.	8.0 Cu.Ft.
-----------------	------------

FEATURES

Pull-to-Open Door	Yes
IQ-Touch™ Controls	Yes

Dry System	Luxury-Dry™
Sound System	Luxury-Quiet™
Lighting	
Tumble System	Gentle Tumble™
Moisture Sensor	Yes
Dryer Drum	Painted Steel
Tumble Speed (RPM)	50
Reversible Door	Yes
Adjustable Leveling Legs	Yes
ENERGY STAR®	Yes
NSF® Certified	

CYCLES

Timed Dry (Auto, 60, 30), Heavy Duty, Towels, Normal, Delicates	5
---	---

OPTIONS

Temperature Selections	3
------------------------	---

Electronic Auto Dry System	
Manual Timed Dry Selections	3
Eco	Yes
End-of-Cycle Chime	On/Off
Extended Tumble	
Anti-Static	
Line Dry	
Shrink Guard	
Dryness Levels	3

INSTALLATION OPTIONS

Freestanding, Under Counter*, Stacked (Above Washer), Pedestal, Hidden (In Closet), Second Floor	Yes
4-Way Dryer Venting	Yes

ACCESSORIES

Luxury-Glide® Pedestal with Spacious Storage Drawer – Island White – PN# EPWD157SIW	Optional
Dryer Stacking Kit – PN# STACKIT7X	Optional
Drying Rack – PN# A04840701	Optional

SPECIFICATIONS

Color –	
Island White	IW
Maximum Exhaust Duct Length** (Ft.)	125
Power Supply Connection Location	Rear
Voltage Rating	240V / 60 Hz / 30A
Connected Load (kW Rating) @ 240 Volts	6.0
Amps @ 240 Volts	25
Heating Element @ 240 Volts (Watts)	4,700
Shipping Weight (Approx.)	140 Lbs.

*Side-by-Side units in under-counter installation require custom-built countertop and/or cabinetry.

**Rigid metal duct preferred, semi-rigid optional and allow deductions for elbows and vents.

Refer to Installation Guide on web for additional information.

NOTE: Always consult local and national electric and plumbing codes. Refer to Product Installation Guide for detailed installation instructions on the web at electroluxappliances.com.

Specifications subject to change.

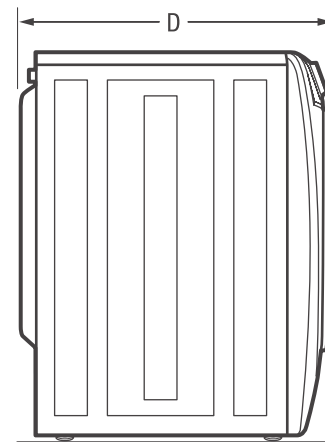
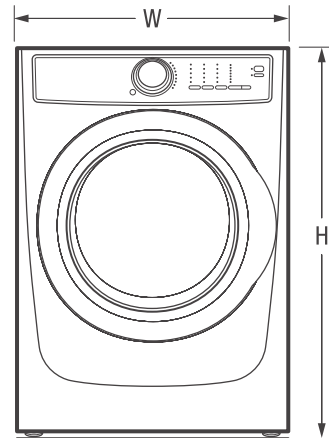

PRODUCT DIMENSIONS

Height (without 15" Pedestal)	38"
(with 15" Pedestal)	53-1/4"
Width	27"
Depth (to Center of Arc Not Including Hose)	31-5/8"
(with Door 90° Open)	53-1/2"

Electrolux Major Appliances, N.A.

USA • 10200 David Taylor Drive • Charlotte, NC 28262 • 1-877-4electrolux (1-877-435-3287) • electroluxappliances.com
 CANADA • 5855 Terry Fox Way • Mississauga, ON L5V 3E4 • 1-800-265-8352 • electroluxappliances.ca

EFDE317T 01/17

© 2017 Electrolux Home Products, Inc.



High standards of quality at Electrolux Home Products, Inc. mean we are constantly working to improve our products. We reserve the right to change specifications or discontinue models without notice.

ELECTRIC FRONT LOAD DRYER

EFDE317TIW

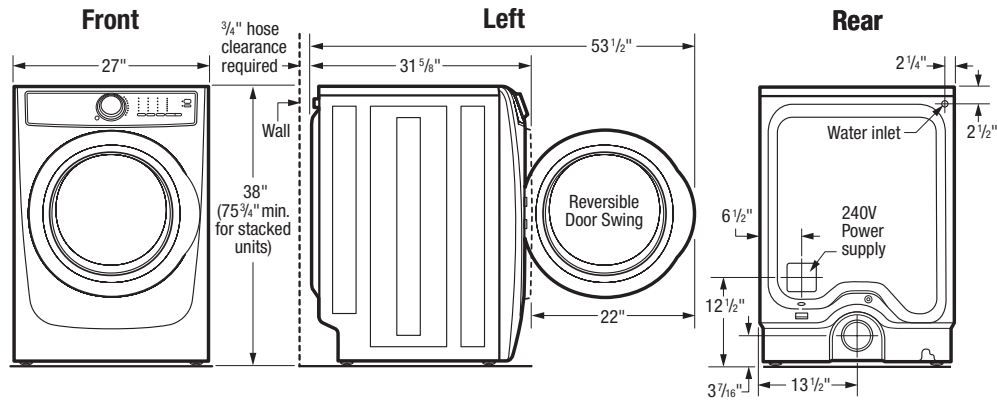

15" Pedestal Drawer Installation

Elevates dryer height to 53 1/4". For detailed pedestal installation, refer to instructions included with pedestal or on web. Pedestal Installation may require modified utility hookup locations. For details, refer to Product Installation Guide on web.

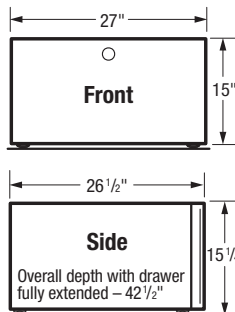

Built-In Installations

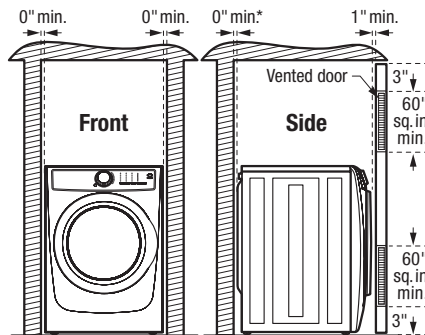

*Steam dryer requires additional 3/4" hose clearance.

Closet Installation:

If washer and dryer are installed in same closet, door(s) MUST be vented with 120 sq. in. minimum louvered opening, equally divided, located 3" from top and bottom of door. Louvered door(s) with equivalent air openings for full-length of door is acceptable. Air openings MUST remain unobstructed with door(s) installed.

Installation Clearances:

Dryer can be built in alone or with washer (side by side or stacked) in closet, recess or under counter installation with 0" minimum clearance required around sides and back of unit(s). To achieve 0" minimum rear clearance, dryer MUST be vented straight back or with quick-turn 90° elbow. Steam dryer requires additional 3/4" steam hose clearance at back of unit(s). Installation of closet door(s) requires additional 1" minimum clearance between front of unit(s) and door(s). Location of plumbing, exhaust and utility hookups MUST be considered when planning any built-in installation. For additional installation details, refer to Product Installation Guides on web.

Under Counter Installation:

Installation of dryer alone or side by side with washer under counter, requires custom-built countertop and/or cabinetry to accommodate unit(s) height.

Stacking Units:

Stacking dryer above washer requires use of optional Stacking Kit (PN# STACKIT7X) with modified utility hookup locations for dryer. For complete installation details, refer to instructions included with Stacking Kit or on web.

Electric Dryer Specifications

- Product Weight – 130 Lbs. / Shipping Weight – 140 Lbs.
- Voltage Rating – 240V / 60 Hz / 30A
- Single phase 3- or 4-wire cable, 240 Volt, 60 Hertz AC only electrical supply with ground required on separate circuit fused on both sides of line. (Do not use same circuit as washer.)
- Connected Load (kW Rating) @ 240 Volts = 6.0 kW
- Amps @ 240V = 25A
- Dryer MUST employ a 3-conductor NEMA 10-30 type SRDT or 4-conductor NEMA 14-30 type SRDT or ST (as required), rated at 240 volt AC minimum, 30 amp power supply cord marked for use with clothes dryers (not supplied).
- Grounding through neutral link prohibited in specific applications and certain locales, requiring use of 4-wire system. (For detailed electrical requirements, refer to Product Installation Guide on web.)
- Always consult local and national electric & plumbing codes.
- Can be installed alone, with or without optional 15" pedestal drawer, or stacked above matching Electrolux Washer, which requires installation of optional dryer stacking kit. (For installation details, refer to instructions included with optional pedestal or stacking kit or on web.)
- Can be built in alone or with matching Electrolux Washer (side by side or stacked) in closet, recess or under counter installation with 0" minimum clearance required around sides and back of unit(s). To achieve 0" minimum rear clearance, dryer MUST be vented straight back or with quick-turn 90° elbow. Steam dryer requires additional 3/4" steam hose clearance at back of unit(s). Installation of closet door(s) requires additional 1" minimum clearance between front of unit(s) and door(s). Location of plumbing, exhaust and utility hookups MUST be considered when planning any built-in installation.
- Under-counter installation requires custom-built countertop and/or cabinetry to accommodate unit(s) height.
- Do NOT install in area exposed to dripping water or outdoor weather conditions, or where gasoline or other flammables, including automobiles, are kept or stored.
- For garage installation, dryer MUST be located minimum 18" above floor.
- Floor MUST be solid with 1" maximum slope. To ensure vibration or movement does not occur, reinforcement of floor may be necessary. Do NOT install on carpeted surface.
- Dryer MUST exhaust to outside of building, NOT into any concealed space.
- Dryer equipped for 4-way venting and approved for up to 125-foot-equivalent of duct length, determined by length of run and number of elbows needed.
- Exhaust installation requires minimum 4"-diameter rigid or semi-rigid metal duct with approved, unobstructed vent hood having swing-out damper(s). If installing rigid metal duct (preferred), do not exceed MAXIMUM venting run length of 125 ft., allow deductions for elbows and vents. If installing semi-rigid metal duct, do not exceed MAXIMUM venting run length of 8 ft., always allow deductions for elbows and vents (Refer to Product Installation Guide on web for additional information). Do NOT use flexible plastic or metal foil duct and use shortest run possible.
- Leveling legs supplied to level dryer properly and reduce excessive noise and vibration.
- Water inlet hose for steam setting connects to cold water supply with "Y" connector and requires 3/4" clearance between back of unit and wall.

Note: For planning purposes only. Refer to Product Installation Guide on the web at electroluxappliances.com for detailed instructions.

Optional Accessories

- Pedestal Drawers – Island White (PN# EPWD157SIW).
- Dryer Stacking Kit – (PN# STACKIT7X).
- Drying Rack – (PN# A04840701).



Electrolux Major Appliances, N.A.

USA • 10200 David Taylor Drive • Charlotte, NC 28262 • 1-877-4electrolux (1-877-435-3287) • electroluxappliances.com
 CANADA • 5855 Terry Fox Way • Mississauga, ON L5V 3E4 • 1-800-265-8352 • electroluxappliances.ca

EFDE317T 01/17

© 2017 Electrolux Home Products, Inc.

High standards of quality at Electrolux Home Products, Inc. mean we are constantly working to improve our products. We reserve the right to change specifications or discontinue models without notice.

FRONT LOAD WASHER

4.3 Cu. Ft.

EFLW317TIW

With LuxCare™ Wash and IQ-Touch™ Controls



PRODUCT DIMENSIONS

Height	38"
Width	27"
Depth	32"

MORE EASY-TO-USE FEATURES

5 CYCLES TO CARE FOR EVERY FABRIC

Clean all your special items with tailored cycles for delicates, heavy duty, and more.

FITS MORE ROOMS

With four-way venting and a standard 27" platform, our products are designed to fit just about anywhere you want to put them.

SPACIOUS CAPACITY

Easily cleans a king-sized comforter with spacious 4.3 cu. ft. drum.

Available in:



Island White
(IW)

*As tested on conventional wood floor construction with vinyl floor covering.

SIGNATURE FEATURES



THOROUGH CLEANING WITH THE LUXCARE™ WASH SYSTEM

Our LuxCare™ Wash System offers a thorough clean with improved wash actions, temperature control, and smart load sensing.



ENERGY STAR®-CERTIFIED

Electrolux washers meet strict criteria to guarantee high-quality energy efficient performance — without sacrificing clean.



10-YEAR MOTOR WARRANTY PLUS LIFETIME TUB WARRANTY

Rest easy knowing your washer is backed by a 10-year motor and lifetime tub warranty.



PERFECT BALANCE® SYSTEM & SECOND FLOOR GUARANTEE

Balances loads for smooth, quiet operation. So quiet* you can even run your washer on the second floor or near bedrooms without noticing it.

FRONT LOAD WASHER

EFLW317TIW



27" FRONT LOAD WASHER

Capacity D.O.E.	4.3 Cu.Ft.
-----------------	------------

FEATURES

Pull-to-Open Door	Yes
IQ-Touch™ Controls	Yes

Balance System	Perfect Balance®
Sound System	Luxury-Quiet™
Lighting	
Pull-to-Open Dispenser Drawer	Yes
Wash System	LuxCare™
Integral Water Heater	
Wash Drum	Stainless Steel
Automatic Temperature Control	Yes
Automatic Water Level Adjustment	Yes
Auto Prewash Detergent Dispenser (Liquid/Powder)	
Auto Bleach Dispenser (Liquid Only)	Yes
Auto Detergent Dispenser (Liquid/Powder)	Yes
Auto Fabric Softener Dispenser (Liquid Only)	Yes
Tumble Speed (RPM)	Variable
Spin Speed (RPM)	1,100
Reversible Door	
Adjustable Leveling Legs	Yes
ENERGY STAR®	Yes
NSF® Certified	

CYCLES

Heavy Duty, Normal, Delicates, Rinse & Spin, Clean Washer	5
---	---

OPTIONS

Wash/Rinse Temperature Combinations	4
Temperature Selections	3

Spin Speed Selections	3
Soil Level Selections	3
Delay Start	Yes
End-of-Cycle Chime	On/Off

INSTALLATION OPTIONS

Freestanding, Under Counter*, Stacked (Under Dryer), Pedestal, Hidden (In Closet), Second Floor	Yes
---	-----

ACCESSORIES

Luxury-Glide® Pedestal with Spacious Storage Drawer – Island White – PN# EPWD157SIW	Optional
Dryer Stacking Kit – PN# STACKIT7X	Optional
Drain Hose Extension Kit – PN# 137098000	Optional

SPECIFICATIONS

Color –	
Island White	IW
Power Supply Location	Top Right Rear
Water Inlet Location	Top Left Rear
Voltage Rating	120V/60 Hz
Connected Load (kW Rating) @ 120 Volts†	1.2
Watts @ 120 Volts	1,200
Amps @ 120 Volts	12
Shipping Weight (Approx.)	247 Lbs.

*Side-by-Side units in under-counter installation require custom-built countertop and/or cabinetry.

†An electrical supply with grounded three-prong receptacle is required. The power supply circuit must be installed in accordance with current edition of National Electrical Code (NFPA 70) and local codes & ordinances.

NOTE: Always consult local and national electric and plumbing codes. Refer to Product Installation Guide for detailed installation instructions on the web at electroluxappliances.com.

Specifications subject to change.

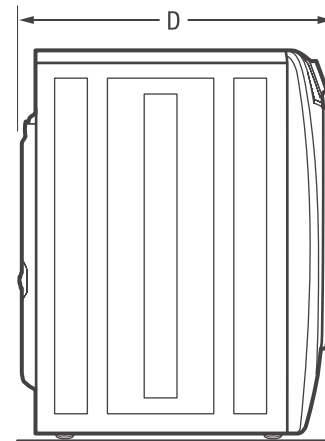
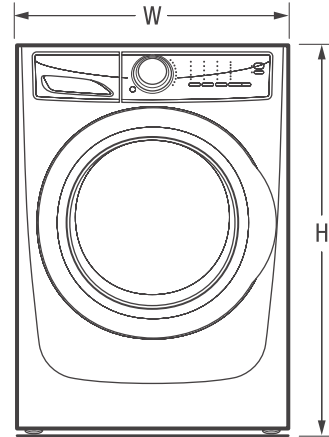

PRODUCT DIMENSIONS

Height (without 15" Pedestal)	38"
(with 15" Pedestal)	53-1/4"
Width	27"
Depth (to Center of Arc Not Including Hose)	32"
(with Door 90° Open)	53-1/2"

Electrolux Major Appliances, N.A.

USA • 10200 David Taylor Drive • Charlotte, NC 28262 • 1-877-4electrolux (1-877-435-3287) • electroluxappliances.com
 CANADA • 5855 Terry Fox Way • Mississauga, ON L5V 3E4 • 1-800-265-8352 • electroluxappliances.ca

EFLW317T 01/17

© 2017 Electrolux Home Products, Inc.



High standards of quality at Electrolux Home Products, Inc. mean we are constantly working to improve our products. We reserve the right to change specifications or discontinue models without notice.

FRONT LOAD WASHER

EFLW317TIW

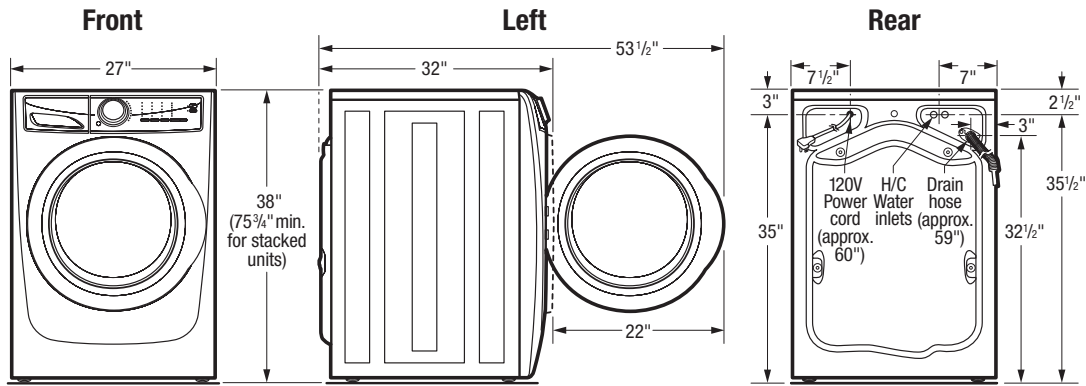

15" Pedestal Drawer Installation

Elevates washer height to 53 1/4". For detailed pedestal installation, refer to instructions included with pedestal or on web. Pedestal Installation may require modified utility hookup locations. For details, refer to Product Installation Guide on web.

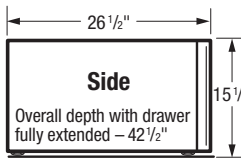
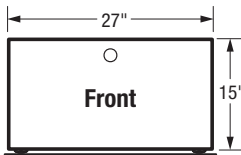

Built-In Installations

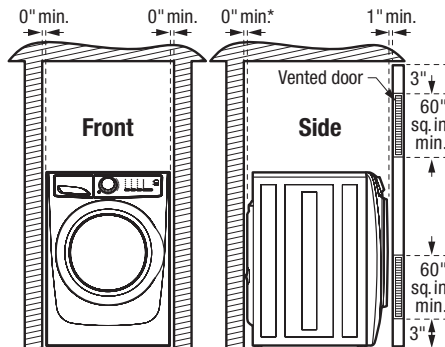

*Installation with steam dryer requires additional 3/4" hose clearance.

Closet Installation:

If washer and dryer are installed in same closet, door(s) MUST be vented with 120 sq. in. minimum louvered opening, equally divided, located 3" from top and bottom of door. Louvered door(s) with equivalent air openings for full-length of door is acceptable. Air openings MUST remain unobstructed with door(s) installed.

Installation Clearances:

Washer can be built in alone or with dryer (*side by side or stacked*) in closet, recess or under counter installation with 0" minimum clearance required around sides and back of unit(s). To achieve 0" minimum rear clearance when installed with dryer, dryer MUST be vented straight back or with quick-turn 90° elbow. Steam dryer requires additional 3/4" steam hose clearance at back of unit(s). Installation of closet door(s) requires additional 1" minimum clearance between front of unit(s) and door(s). Location of plumbing, exhaust and utility hookups MUST be considered when planning any built-in installation. For additional installation details, refer to Product Installation Guides on web.

Under Counter Installation:

Installation of washer alone or side by side with dryer under counter, requires custom-built countertop and/or cabinetry to accommodate unit(s) height.

Stacking Units:

Stacking dryer above washer requires use of optional Stacking Kit (PN# STACKIT7X) with modified utility hookup locations for dryer. For complete installation details, refer to instructions included with Stacking Kit or on web.

Front Load Washer Specifications

- Product Weight – 237 Lbs. / Shipping Weight – 247 Lbs.
- An electrical supply with grounded three-prong receptacle is required. The power supply circuit must be installed in accordance with current edition of National Electrical Code (ANSI/NFPA 70) and local codes & ordinances. (*Do not use same circuit as dryer.*)
- Voltage Rating – 120V/60Hz
- Connected Load (kW Rating) @ 120 Volts = 1.2 kW
- Amps @ 120V = 12A
- Equipped with 120V 3-wire power supply cord, approx. 60" long.
- Always consult local and national electric & plumbing codes.
- To maximize detergent effectiveness, ambient temperature should never be below 60°F.
- Can be installed alone, with or without optional 15" pedestal drawer, or stacked beneath matching Electrolux Dryer, which requires installation of optional dryer stacking kit. (*For installation details, refer to instructions included with optional pedestal or stacking kit or on web.*)
- Can be built in alone or with matching Electrolux Dryer (*side by side or stacked*) in closet, recess or under counter installation with 0" minimum clearance required around sides and back of unit(s). To achieve 0" minimum rear clearance when installed with dryer, dryer MUST be vented straight back or with quick-turn 90° elbow. Steam dryer requires additional 3/4" steam hose clearance at back of unit(s). Installation of closet door(s) requires additional 1" minimum clearance between front of unit(s) and door(s). Location of plumbing, exhaust and utility hookups MUST be considered when planning any built-in installation.
- Under-counter installation requires custom-built countertop and/or cabinetry to accommodate unit(s) height.

- Do NOT install in area exposed to dripping water or outdoor weather conditions, or where gasoline or other flammables, including automobiles, are kept or stored.
- For garage installation, washer MUST be located minimum 18" above floor.
- Floor MUST be solid with 1" maximum slope. To ensure vibration or movement does not occur, reinforcement of floor may be necessary. Do NOT install on carpeted surface.
- Leveling legs supplied to level washer properly and reduce excessive noise and vibration.
- H/C water faucets MUST be installed within 42" of washer's water inlet and MUST be 3/4" garden hose type, to connect to 48-1/2" inlet hoses.
- Water pressure MUST be between 30 and 120 psi with NOT more than 10 psi pressure difference between hot and cold.
- Drain required with standpipe diameter of 1-1/4" min. and height of 24" min./96" max. above floor, capable of eliminating 17 gallons per minute. Attached 59" drain hose can reach 79"-high standpipe.

Note: For planning purposes only. Refer to Product Installation Guide on the web at electroluxappliances.com for detailed instructions.

Optional Accessories

- Pedestal Drawers – Island White (PN# EPWD157SIW).
- Dryer Stacking Kit – (PN# STACKIT7X).
- Drain Hose Extension Kit – (PN# 137098000).

Electrolux Major Appliances, N.A.

USA • 10200 David Taylor Drive • Charlotte, NC 28262 • 1-877-4electrolux (1-877-435-3287) • electroluxappliances.com
 CANADA • 5855 Terry Fox Way • Mississauga, ON L5V 3E4 • 1-800-265-8352 • electroluxappliances.ca

EFLW317T 01/17

© 2017 Electrolux Home Products, Inc.



High standards of quality at Electrolux Home Products, Inc. mean we are constantly working to improve our products. We reserve the right to change specifications or discontinue models without notice.



Dishwashers

FDB2410HI C/S/B

24" Built-In



Product Dimensions

Height (Adjustable)	32-1/2" - 34-7/8"
Width	24"
Depth (Including Door)	23"

More Easy-To-Use Features

Multiple Cycle Options

Features easy-to-use cleaning cycle options.

Delay Start

Set your dishwasher to run on your schedule.

Ready-Select® Controls

Easily select options with the touch of a button.

Energy Saver Plus Cycle

Eco-friendly cycle uses less energy without compromising cleaning performance.

Energy Saver Dry Option

No heat dry option.

Attractive Stainless Steel Exterior¹

Low Rinse-Aid Indicator Light

Control Lock Option

5-Level Wash Design

UltraQuiet™ 3

Sound Reduction System

ENERGY STAR®
A.D.A. Compliant²



Available in:



Stainless
(C)



White
(S)



Black
(B)

Signature Features

Stainless Steel Interior

Premium stainless steel interior for maximum durability.

Tall-Tub Design

Our large capacity, tall-tub dishwasher fits up to 12 place settings so you can wash more at once.

Quiet Dishwasher

A quiet performance every time.

SpaceWise® Silverware Basket

There's a place for all of your silverware in our multicompartment, removable basket.

¹Select model only.

²When properly installed, meets the appliance standards in the Americans with Disabilities Act and the Architectural Barriers Act Accessibility Guidelines as published by the United States Access Board on June 23, 2004, as amended August 5, 2005.

Features	
Control Design	Ready-Select®
Digital Display	Yes
Door Latch	Yes
Stay-Put Door Hinge Design	Yes
Low Rinse-Aid Indicator Light	Yes
Interior Design	Tall Tub
Interior Color	Stainless Steel
Wash System	Direct
Wash Levels/Wash Speeds	5/1
Sound Package	UltraQuiet™ 3
Filter	Stainless Steel
Filter Trap	Removable
Soft Food Disposer	Yes
dB Level	56
Drying System	Static
Cycles	
Number of Cycles	5
Heavy	Yes
Normal	Yes
Light	
Delicate	
Favorite	
China/Crystal	Yes
Rinse Only	Yes
Energy Saver Plus	Yes
Upper Rack Wash Only	
Cycle Indicator Light	
Control Lock	Yes
Options	
Heat/No Heat Dry	Yes
Hi-Temp Wash	Yes
NSF® Certified Sanitize Rinse	
Delay Start	1-24 Hour
Rack System	
Rack Design/Rack Coating	Deluxe/Nylon TuffRacks™
Upper Rack -	
Stemware/Champagne Glass Holders	Yes
Fold-Down Tines	Yes
Cup Shelves	2
Lower Rack -	
SpaceWise® Silverware Basket	3-Piece Split
Fold-Down Tines	
Small Items Cover	3
Certifications	
ENERGY STAR®	Yes
A.D.A. Compliant ¹	Yes
Specifications	
Water Inlet Location	Left Bottom Front
Water Usage (Gallons)	5.4
Water Pressure (PSI)	20 - 120
Integral Air Gap on Supply	Yes
Leveling Legs	4
Power Supply Connection Location	Right Bottom Front
Voltage Rating	120V / 60 Hz / 15A
Connected Load (kW Rating) @ 120 Volts ²	1.44
Amps @ 120 Volts	10
Shipping Weight (Approx.)	69 Lbs.

¹When properly installed, meets the appliance standards in the Americans with Disabilities Act and the Architectural Barriers Act Accessibility Guidelines as published by the United States Access Board on June 23, 2004, as amended August 5, 2005.

²For use on adequately wired 120V, dedicated circuit having 2-wire service with a separate ground wire. Appliance must be grounded for safe operation.

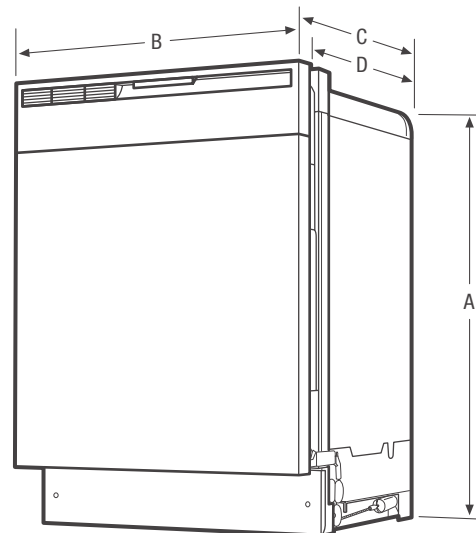

NOTE: For planning purposes only. Always consult local and national electric and plumbing codes. Refer to Product Installation Guide for detailed installation instructions on the web at frigidaire.com.



Product Dimensions	
A - Height (Adjustable)	32-1/2" - 34-7/8"
B - Width	24"
C - Depth (Including Door)	23"
D - Depth (To Tub Flange)	20-1/2"
Depth with Door Open 90°	46"

Cutout Dimensions	
Height (Min.)	32-1/2" (A.D.A!)
Height (Max.)	35"
Width (Max.)	24"
Depth (Min.)	24"

Accessories information available on the web at frigidaire.com

FRIGIDAIRE

USA • 10200 David Taylor Drive • Charlotte, NC 28262 • 1-800-FRIGIDAIRE • frigidaire.com
 CANADA • 5855 Terry Fox Way • Mississauga, ON L5V 3E4 • 1-800-265-8352 • frigidaire.ca

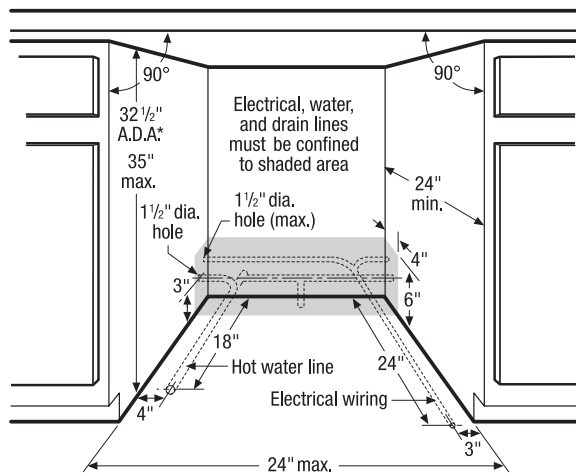
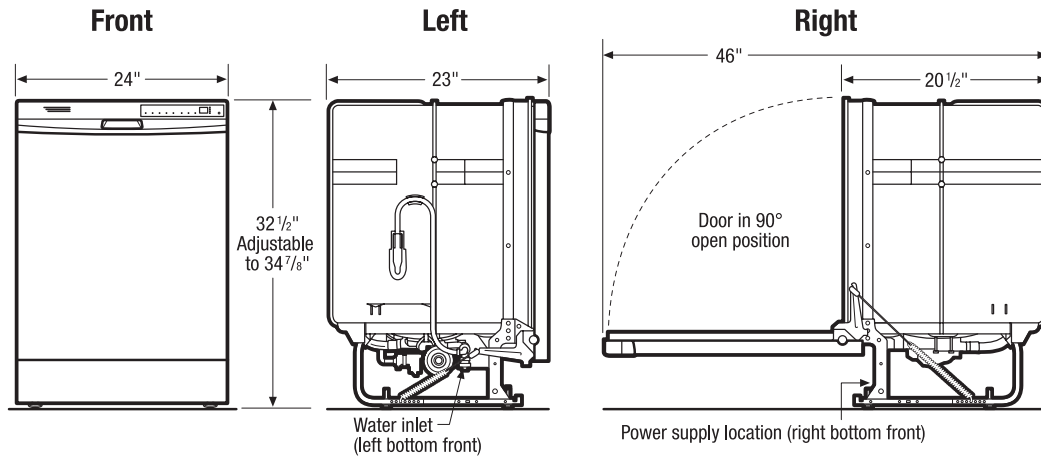

*A.D.A. installation, (32 1/2") beneath 34"-high countertop may be accomplished by adjusting toekick and leveling legs.

Dishwasher Specifications

- Product Shipping Weight (approx.) - 69 Lbs.
- Voltage Rating - 120V/60 Hz/15 Amps (maximum 20 Amps if connected with disposer)
- Connected Load (kW Rating) @ 120 Volts = 1.44 kW (For use on adequately wired 120V, dedicated circuit having 2-wire service with a separate ground wire. Appliance must be grounded for safe operation.)
- Amps @ 120V = 10 Amps
- Always consult local and national electric & plumbing codes. Meets requirements of ASSE 1006 – integral air gap on supply.
- Dishwasher enclosure requires that adjacent cabinets be square and plumb. Unit must be fully enclosed on top, sides and back; and not support any part of enclosure.
- For A.D.A. installation, (32 1/2") beneath 34"- high countertop may be accomplished by adjusting toekick and leveling legs.
- When installing unit adjacent to wall, cabinet or other obstruction that extends beyond front edge of unit, allow 2" minimum clearance between opened door and obstruction.
- Do not install unit beneath cooktop, damage will occur.

- Make sure location has required drain, water and electrical outlets to make proper connections.
- Air gap required if drain is connected to waste tee or disposer lower than 18" above floor. If no air gap required, minimum 32"-high drain loop must be used. Total drain hose length must not exceed 10' to drain outlet.
- Electrical and water supplies should enter enclosure on floor, or through rear or cabinet side walls, as shown in designated shaded area. Hot water line may pass through same hole as electrical cable and drain hose; or through additional 1-1/2" dia. hole designated to accommodate line.
- Water connection located on left side of dishwasher. Install hot water inlet line using no less than 3/8" O.D. copper and extend forward at least 18" from rear wall with hand shut-off valve accessible beneath sink.
- Water Pressure - Hot water line to dishwasher must provide between 20 and 120 pounds per square inch (psi).

Note: For planning purposes only. Refer to Product Installation Guide on the web at frigidaire.com for detailed instructions.

Use these dimensions and clearance instructions for planning purposes only. For detailed installation instructions, refer to installation guide, packed with product, or on the web at frigidaire.com.

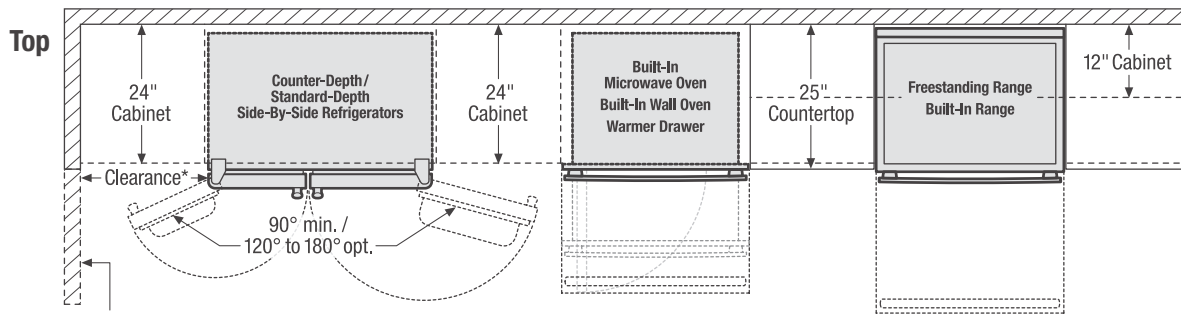
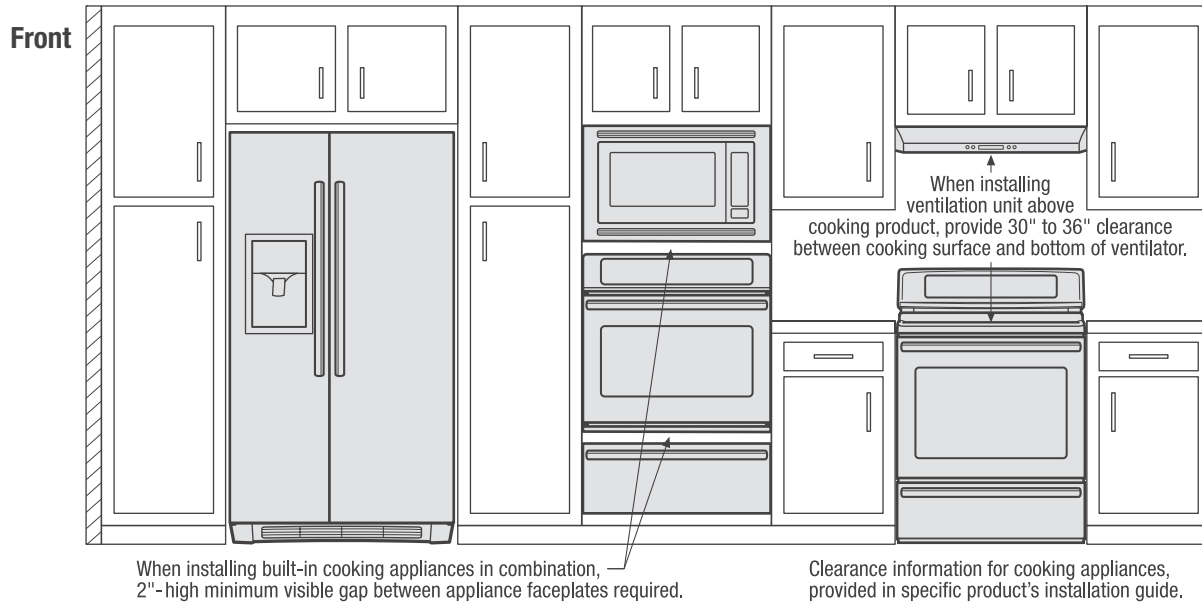

*When installing side-by-side refrigerator adjacent to wall, cabinet or another appliance that extends beyond front edge of unit, 20" minimum clearance recommended to allow for optimum 120° to 180° door swing, providing complete drawer/crisper access and removal. (Absolute 4-1/2" minimum clearance will ONLY allow for 90° door swing which will provide limited drawer/crisper access with restricted removal.)

When installing appliance with sliding drawer, swinging or drop-down door directly across from obstructions, provide sufficient clearance for drawer extension or door swings.

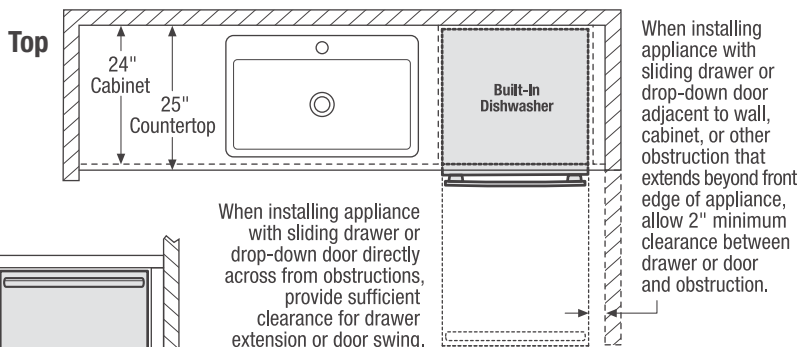

Use these dimensions and clearance instructions for planning purposes only. For detailed installation instructions, refer to installation guide, packed with product, or on the web at frigidaire.com.

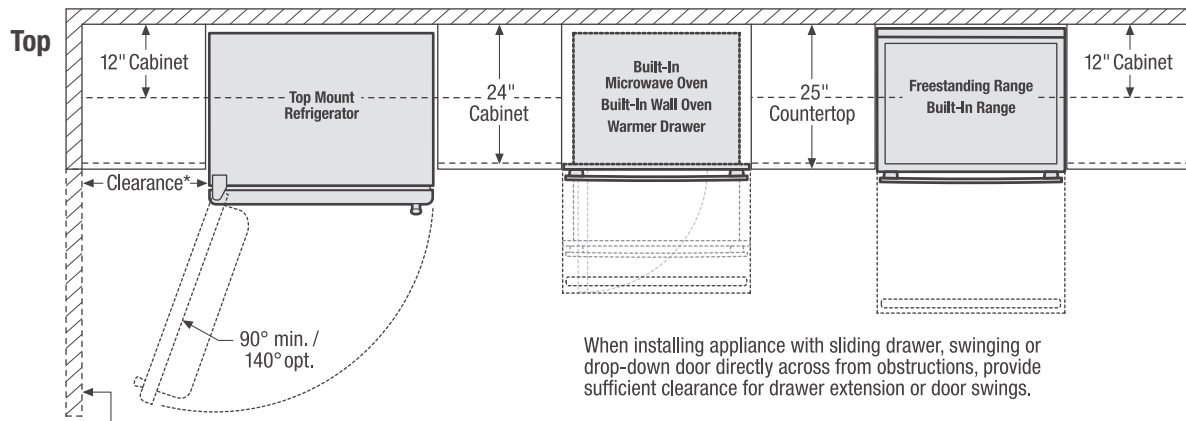
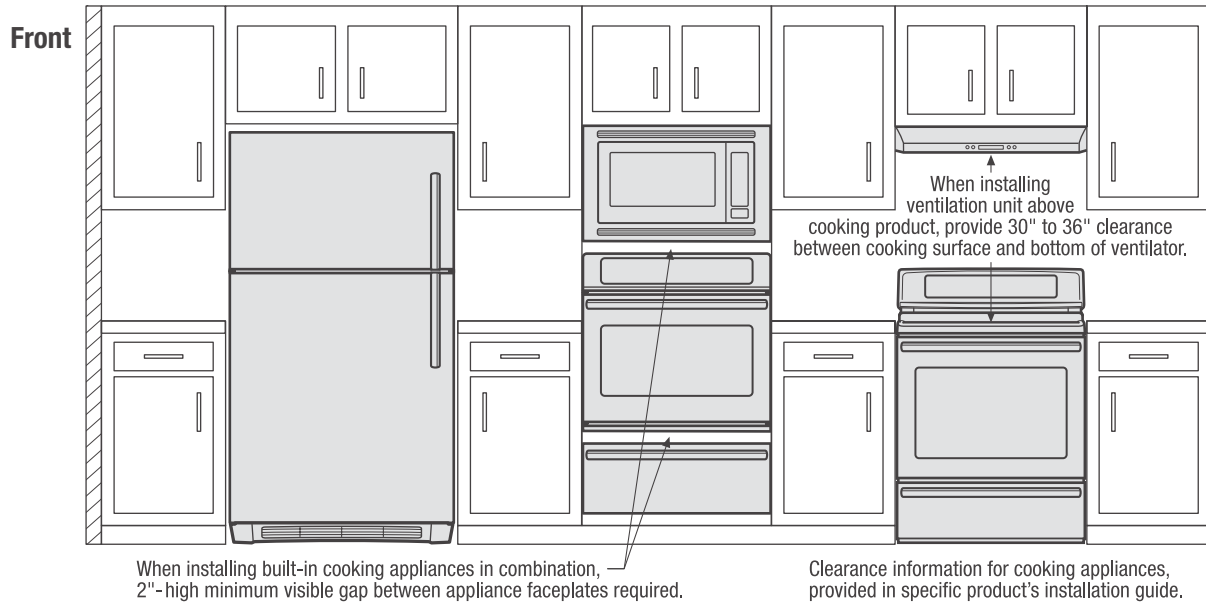

*When installing top mount refrigerator adjacent to wall, cabinet or other appliance that extends beyond front edge of unit, 20" minimum clearance recommended to allow for optimum 140° door swing, providing complete crisper access and removal. (Absolute 3" minimum clearance will ONLY allow for 90° door swing which will provide limited crisper access with restricted removal.)

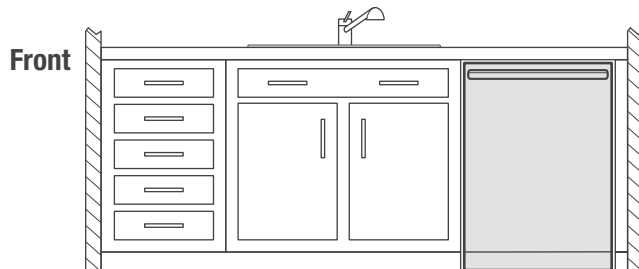
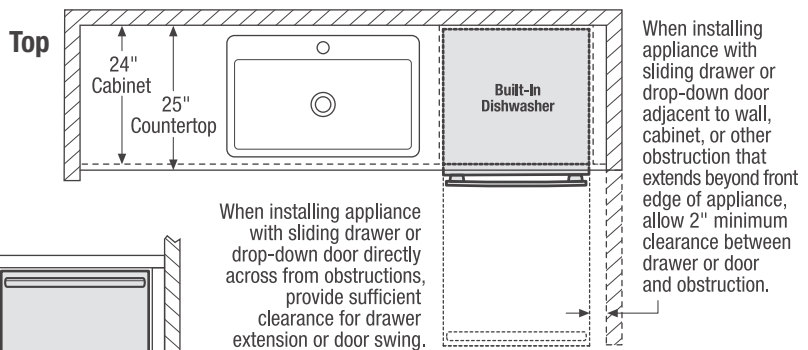

Use these dimensions and clearance instructions for planning purposes only. For detailed installation instructions, refer to installation guide, packed with product, or on the web at frigidaire.com.

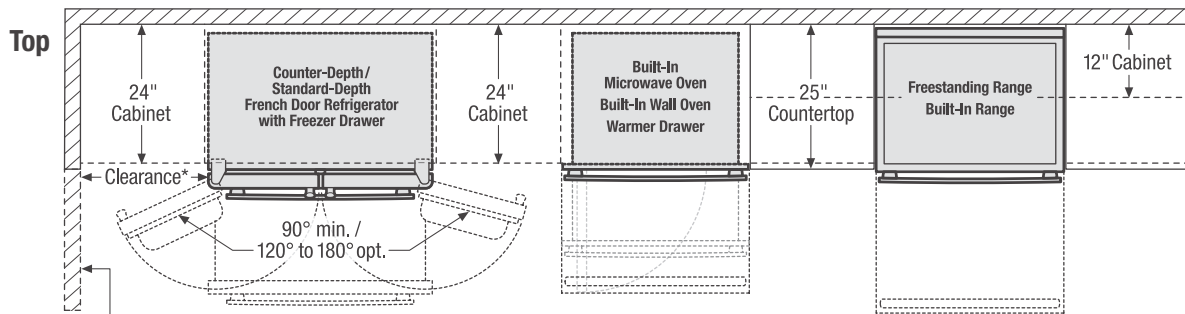
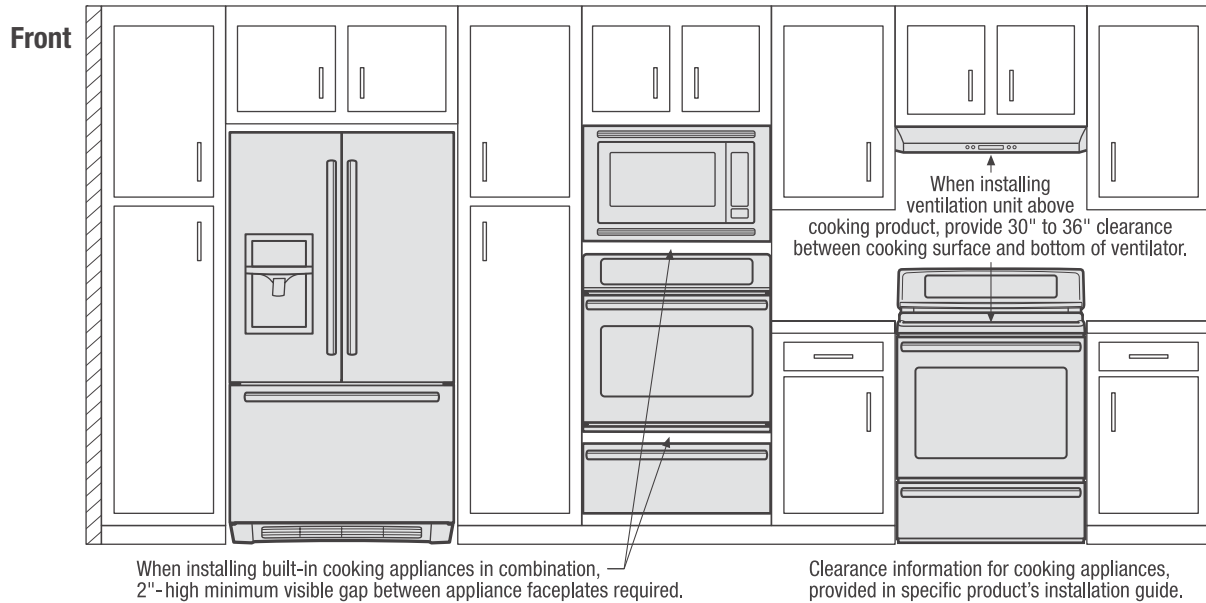

*When installing French door refrigerator adjacent to wall, cabinet or another appliance that extends beyond front edge of unit, 20" minimum clearance recommended to allow for optimum 120° to 180° door swing, providing complete drawer/crisper access and removal. (Absolute 4-1/2" minimum clearance will ONLY allow for 90° door swing which will provide limited drawer/crisper access with restricted removal.)

When installing appliance with sliding drawer, swinging or drop-down door directly across from obstructions, provide sufficient clearance for drawer extension or door swings.

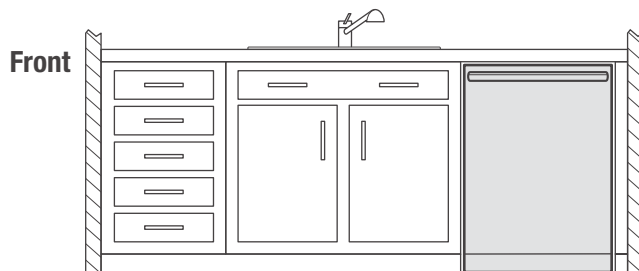
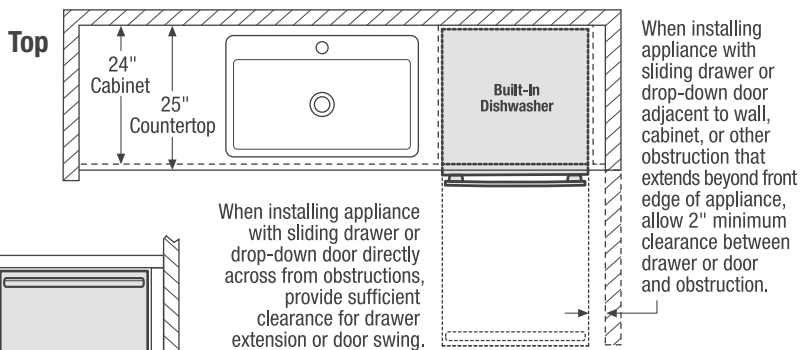

When installing appliance with sliding drawer or drop-down door directly across from obstructions, provide sufficient clearance for drawer extension or door swing.

Use these dimensions and clearance instructions for planning purposes only. For detailed installation instructions, refer to installation guide, packed with product, or on the web at frigidaire.com.

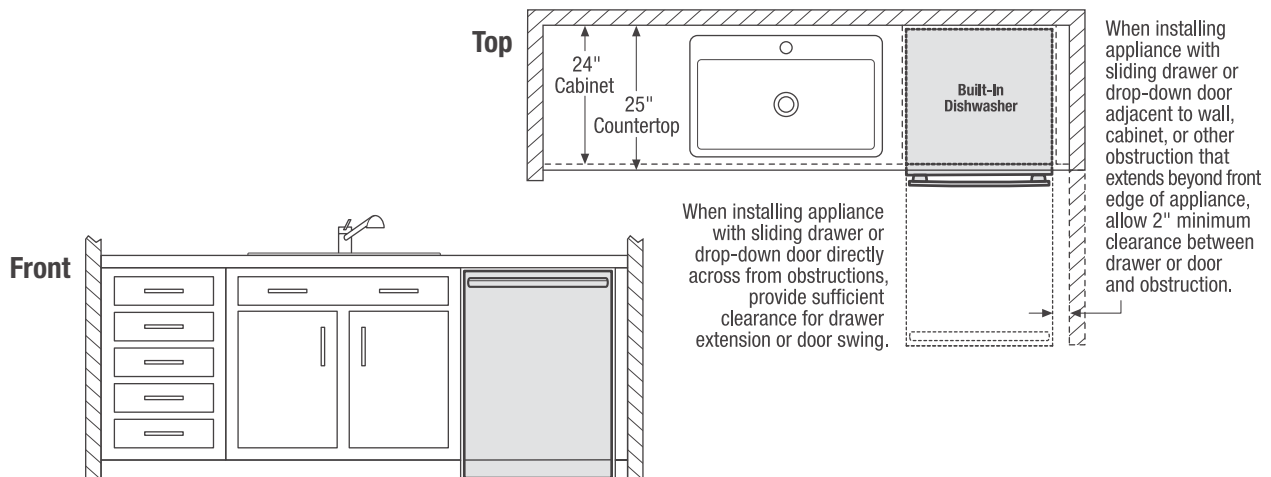
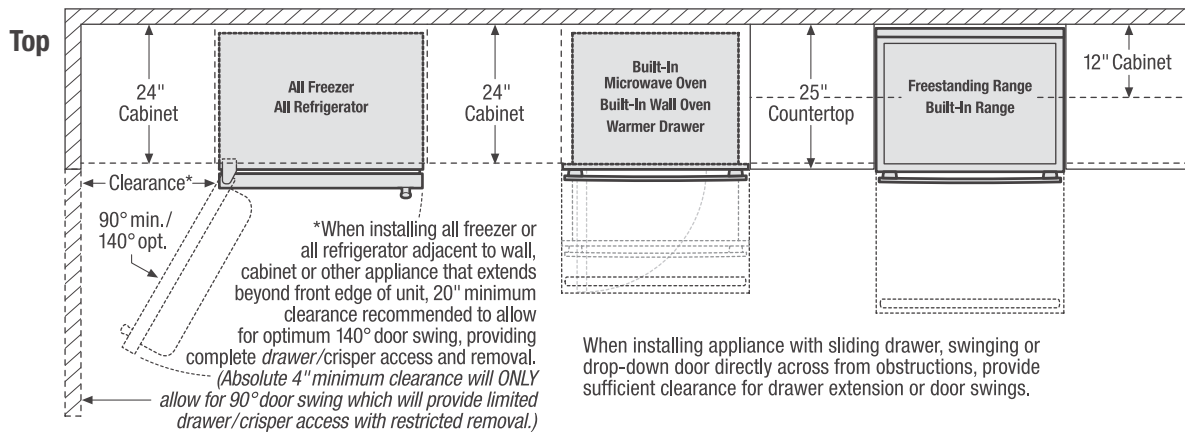
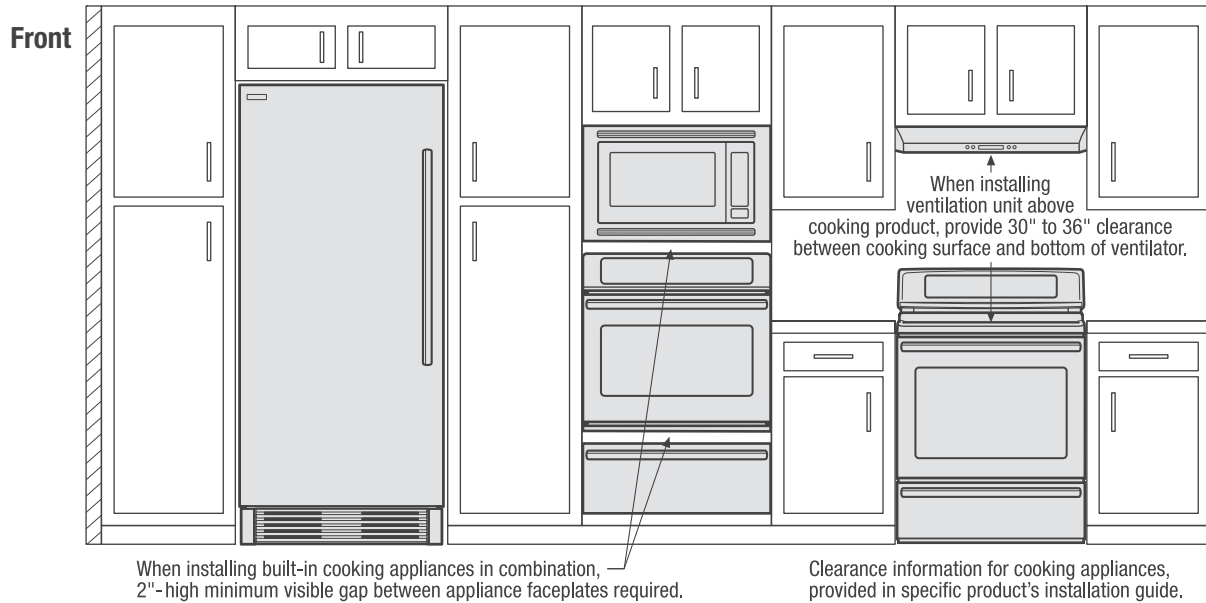

FFCD2413U S/W/B

DISHWASHER

24" BUILT-IN



AVAILABLE COLORS



Stainless



White



Black

PRODUCT DIMENSIONS

Height (Min. - Max.)	33-1/2" - 35"
Width	24"
Depth	25"

MORE EASY-TO-USE FEATURES

ENERGY STAR® Certified

Maximize your energy and dollar savings with ENERGY STAR® Certified Appliances.

Time Saving 4-Hour Delay Start

Set your dishwasher to run on your schedule. It can be set to run 4 hours in advance.

Cycle Status Indicators

Know when your dishes are washing, drying and clean with the status indicators.

Filtration System

Self-cleaning filter eliminates food particles, keeping dishes clean.

Stay-Put Door Allows For Easier Loading

The door stays put at whatever angle you open it for easy loading and unloading.

Durable Polymer Wash Tub

Supports the drying process, keeping dishes dry the first time.

Built with American Pride

Designed, engineered and assembled in the U.S.A.

CERTIFICATIONS

ENERGY STAR®



SIGNATURE FEATURES

A Thorough Clean Every Time

Three separate spray arms give your dishes the ultimate clean every time.

Fits up to 14 Place Settings

Cleans 14 place settings in one cycle.

Heated Drying System

Heating element helps dry your dishes the first time.

Multiple Cleaning Cycle Options

Features easy-to-use cleaning cycle options for your different cleaning needs including Energy Saver, Light Wash and Heavy Wash.

FFCD2413U S/W/B DISHWASHER

FRIGIDAIRE

24" BUILT-IN

FEATURES

Control Design	Ready-Select®
Door Latch / Stay-Put Door Hinge Design	Yes / Yes
Low Rinse-Aid Indicator Light	Yes
Interior Color / Interior Design	Greystone / Tall Tub
Wash System	Direct Feed
Wash Levels / Wash Speeds	5 / 5
Sound Package	UltraQuiet™ I
Filter / Filter Trap	Poly / Removable
Food Disposer	Hard
dB Level	60
Drying System	Static Vent

CYCLES

Number of Cycles	3
PowerPlus™ (Heavy)	Yes
Normal	Yes
Light	Yes
Cycle Indicator Light / Control Lock	Yes / Yes

OPTIONS

Heat / No Heat Dry	Yes / Yes
Hi-Temp Wash	Yes
Delay Start	4 Hours

RACK SYSTEM

Rack Design	Standard
Rack Coating	PVC

Lower Rack -

SpaceWise® Silverware Basket	Standard
------------------------------	----------

Upper Rack -

Rack Type	Basic
-----------	-------

CERTIFICATIONS

ENERGY STAR®	Yes
--------------	-----

SPECIFICATIONS

Water Inlet Location	Left Bottom Front
Water Usage (Gallons)	6.0
Water Pressure (PSI)	20 - 120
Integral Air Gap on Supply	Yes
Leveling Legs	Yes
Power Supply Connection Location	Right Bottom Front
Voltage Rating	120V / 60 Hz / 15A
Connected Load (kW Rating) @ 120 Volts¹	1.44
Amps @ 120 Volts	10.0
Shipping Weight (Approx.)	83 Lbs.

¹For use on adequately wired 120V, dedicated circuit having 2-wire service with a separate ground wire. Appliance must be grounded for safe operation.

PRODUCT DIMENSIONS

A - Height (Min.-Max.)	33-1/2" - 35"
B - Width	24"
C - Depth	25"
Depth with Door Open 90°	49-1/4"

CUTOUT DIMENSIONS

Height (Min.)	33-1/2"
Height (Max.)	35-1/4"
Width (Min.)	24"
Depth (Min.)	24"

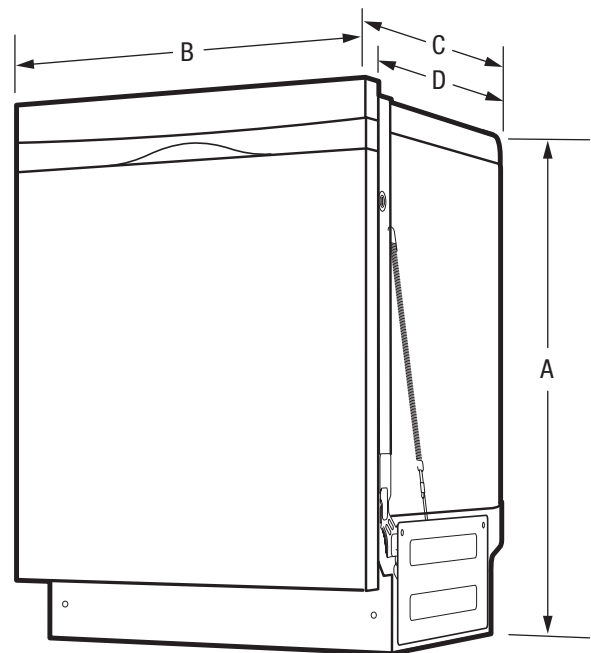

Note: For planning purposes only. Always consult local and national electric, gas and plumbing codes. Refer to Product Installation Guide for detailed installation instructions on the web at frigidaire.com / frigidaire.ca.

Specifications subject to change. Accessories information available on the web at frigidaire.com / frigidaire.ca

FRIGIDAIRE

USA • 10200 David Taylor Drive • Charlotte, NC 28262 • 1-800-FRIGIDAIRE • frigidaire.com
CANADA • 5855 Terry Fox Way • Mississauga, ON L5V 3E4 • 1-800-265-8352 • frigidaire.ca

FFCD2413U 06/18
© 2018 Electrolux Home Products, Inc.

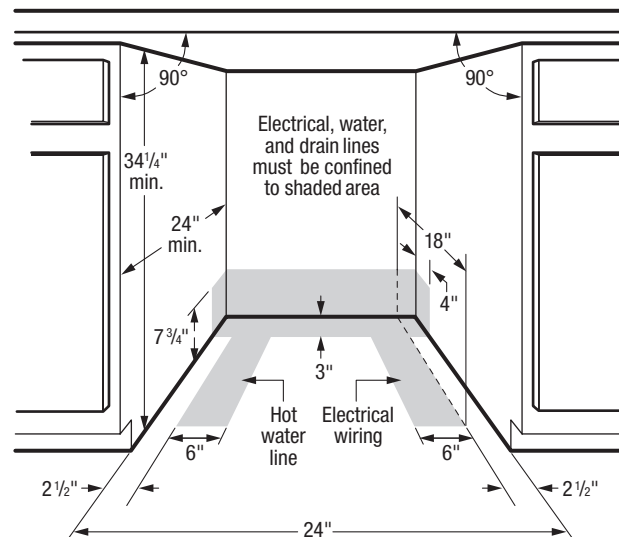
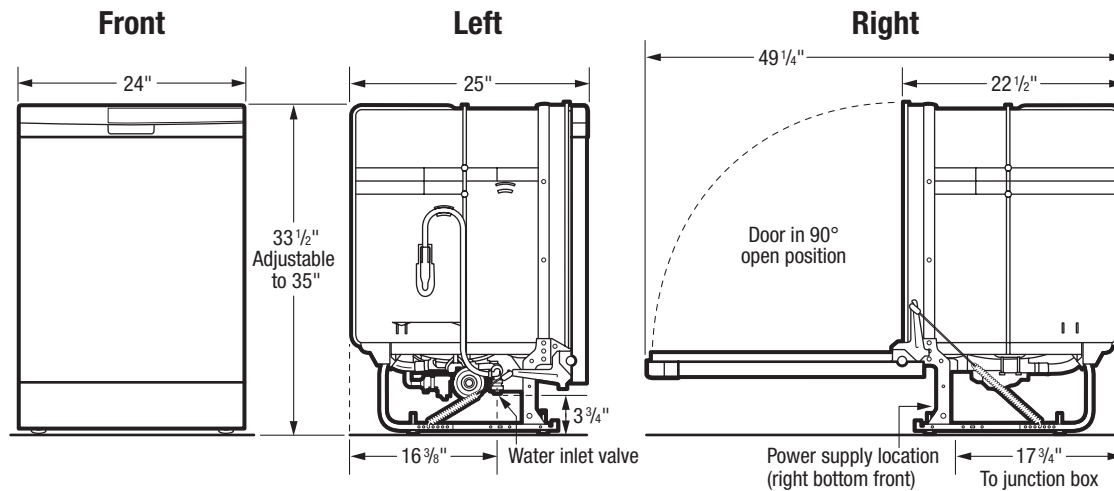

INSTALLATION SPECIFICATIONS

- Product Shipping Weight (approx.) – 83 Lbs.
- Voltage Rating – 120V/60 Hz/15 Amps (maximum 20 Amps if connected with disposer)
- Connected Load (kW Rating) @ 120 Volts = 1.44 kW (For use on adequately wired 120V, dedicated circuit having 2-wire service with a separate ground wire. Appliance must be grounded for safe operation.)
- Amps @ 120V = 10 Amps
- Always consult local and national electric & plumbing codes. Meets requirements of ASSE 1006—integral air gap on supply.
- Water Pressure – Hot water line to dishwasher must provide between 20 and 120 pounds per square inch (psi) with at least 120°F hot water temperature.
- Make sure location has correct drain, water and electrical outlets to make connections—MUST be confined to shaded areas.
- Electrical and water supplies should enter cabinet opening on floor, or through back or side walls, as shown in shaded areas.
- Keep back free of drain, water & electrical supply.
- Connections preferably located toward left side of dishwasher. Do not cross drain, water or electrical lines in front of motor, blower or frame.
- If connecting drain hose to sink trap, local code may require installation of Air Gap Kit (not included).
- Leveling legs supplied to adjust height. (Note: Height only adjustable to 35-3/4" max. when installed in 35-3/4" max. standard cabinetry cutout. 5/16" min. clearance required from top of unit to underside of countertop. Dimensions do NOT include insulation — insulation blanket may be compressed during installation.)
- When installing adjacent to wall, cabinet or other obstruction that extends beyond front edge of unit, allow 2" minimum clearance between opened door and obstruction.
- Floor should be flat and free of obstructions with carpet removed to provide motor clearance.
- When installing at end of cabinet line, sides and back must be fully enclosed.
- Do not install unit under a cooktop, damage will occur.
- Recommended to seal cabinets, enclosing all sides of dishwasher, including underside of countertop, with oil-based paint or moisture-proof polyurethane to prevent possible steam/moisture damage.



Note: For planning purposes only. Always consult local and national electric, gas and plumbing codes. Refer to Product Installation Guide for detailed installation instructions on the web at frigidaire.com / frigidaire.ca.
Specifications subject to change. Accessories information available on the web at frigidaire.com / frigidaire.ca



Microwaves

FFMO1611L S/W/B

22" Countertop



Shown with optional Built-In Trim Kit



Product Dimensions

Height	12-7/8"
Width	21-3/4"
Depth	18-1/2"

More Easy-To-Use Features

Extra-Large 14-1/4" Diameter Glass Turntable

10 Cooking Power Levels

Control Lock Option

Electronic Clock & Timer

Attractive Stainless Steel Exterior¹

Available in:



Stainless
(S)



White
(W)



Black
(B)

¹Select models only.

Signature Features

One-Touch Options

Our microwaves feature easy-to-use one-touch buttons so you can cook baked potatoes, popcorn, or even add 30 seconds with the touch of a button.

Multi-Stage Cooking

Our Multi-Stage Cooking option allows you to program power levels and cooking times in advance, so you can program it to defrost, cook and keep a meal warm all at once.

Ready-Select[®] Controls

Easily select options with the touch of a button.

Sensor Cooking Options

Microwave automatically adjusts power levels and cooking times to cook a variety of items, effortlessly.

Features	
Control/ Timing System	Ready-Select®
Exterior Door Finish	Stainless Steel (S), Color-Coordinated (W/B)
Handle Design	Push Button
Microwave Features	
Microwave Capacity (Cu.Ft.)	1.6
Watts (IEC-705 Test Procedure)	1,100
Interior Light	Yes
Interior Color	White
Turntable Diameter	14-1/4"
Turntable On/Off	
Control Lock	Yes
Clock	Yes
Touch Pad Buttons	23
Power Levels	10
Accessory Metal Rack	
Microwave Control Options	
Easy-Set™ Start	Yes
Popcorn Button	Yes
Chicken Nugget Button	
Baked Potato Button	Yes
Sensor Reheat Button	Yes
Snack Button	
Beverage	
Melt & Soften Options	
Auto Reheat Options	
Snack Menu Options	
Auto Cook Options	Yes
Auto Defrost Options	Yes
Multi-Stage Cooking Option	Yes
Keep Warm	
Add-30-Seconds	Yes
Sensor Cooking Options	8
Vegetable Cook Sensor	Yes
Delay Start	
User Preferences	
Power Ratings	
Frequency (Mhz)	2,450
Watts @ 120 Volts	1,550
Amps @ 120 Volts	13.0
Optional Accessories	
30" Stainless Steel Trim Kit	PN# FFMOTK30LS
30" White Trim Kit	PN# FFMOTK30LW
30" Black Trim Kit	PN# FFMOTK30LB
27" Stainless Steel Trim Kit	PN# FFMOTK27LS
27" White Trim Kit	PN# FFMOTK27LW
27" Black Trim Kit	PN# FFMOTK27LB
Specifications	
Oven Interior (HxWxD)	10-5/16" x 17-1/4" x 15-3/8"
Power Supply Connection Location	Right Top Rear
Voltage Rating	120V/60Hz/15A
Connected Load (kW Rating) @ 120 Volts¹	1.55
Minimum Circuit Required (Amps)	15
Shipping Weight (Approx.)	44 Lbs.

¹For use on adequately wired 120V, dedicated circuit having 2-wire service with a separate ground wire. Appliance must be grounded for safe operation.

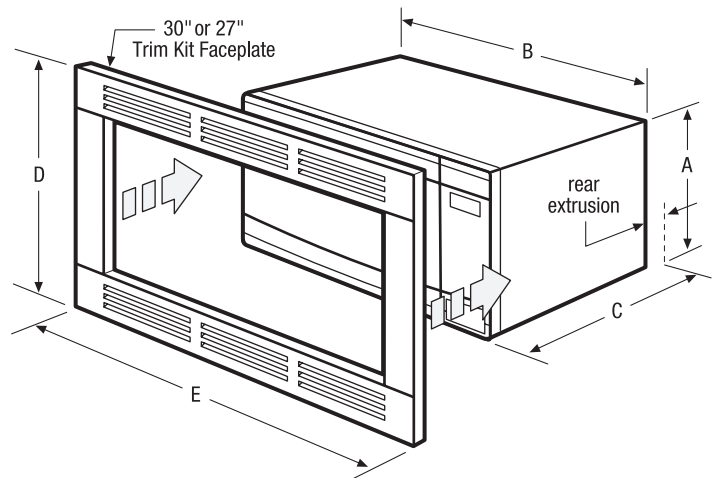

NOTE: For planning purposes only. Always consult local and national electric codes. Refer to Product Installation Guide for detailed installation instructions on the web at frigidaire.com.



Product Dimensions		Cutout Dimensions	
A - Height	12-7/8"	Height (Min.)	17"
B - Width	21-3/4"	Height (Max.)	17-1/4"
C - Depth	18-1/2"	Width (Min.)	24-3/4"
D - Height (Trim Kit Faceplate)	18-1/8"	Width (Max.)	25"
E - Width (30" Trim Kit Faceplate)	29-15/16"	Depth (Min.)	20"
E - Width (27" Trim Kit Faceplate)	26-15/16"		

Accessories information available on the web at frigidaire.com

***Note:** When used in combination with another Frigidaire® built-in product, a minimum clearance of 2⁷/₈" required from bottom of Built-In Microwave cutout to top edge of companion product's faceplate, leaving a 2" visible gap between both product faceplates

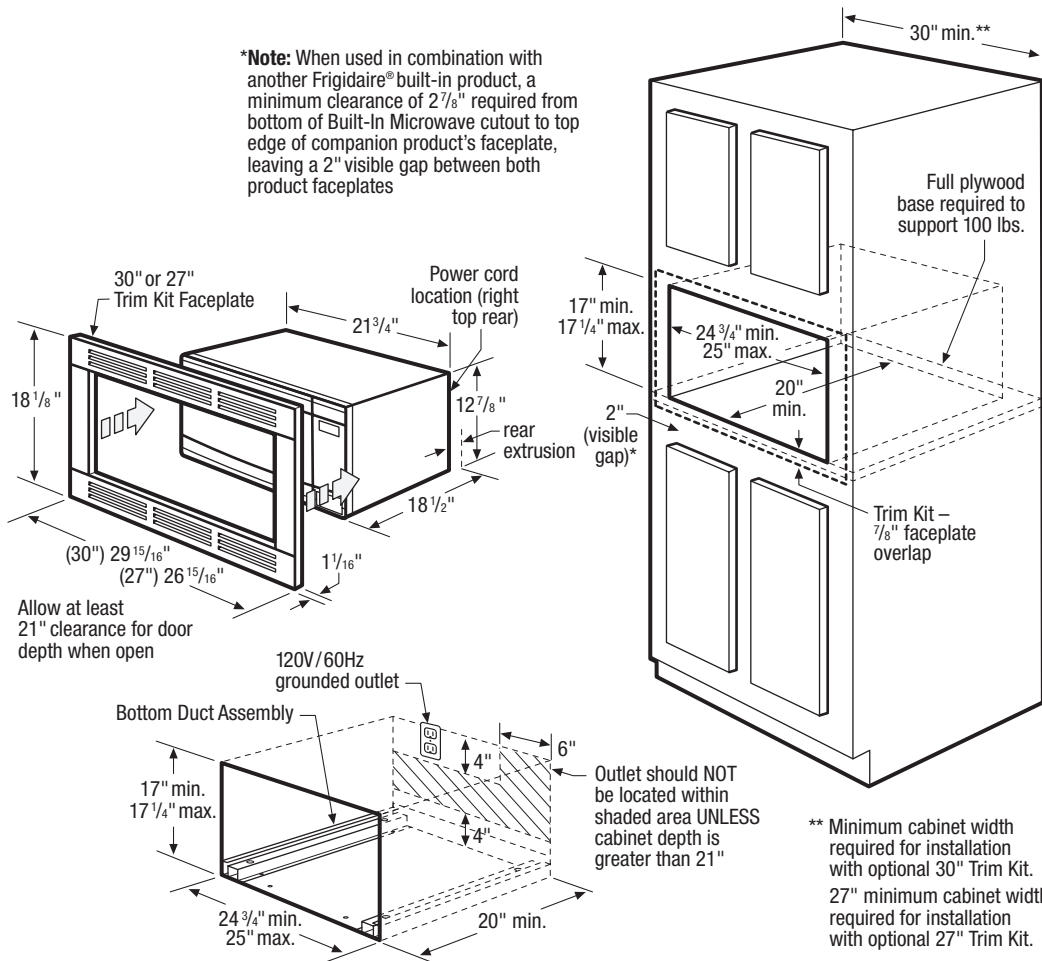

Microwave Specifications

- Product Shipping Weight (Approx.) - 44 Lbs. (not incl. Trim Kit)
- Voltage Rating - 120V/60 Hz/15 or 20 Amps
- Connected Load (kW Rating) @ 120 Volts = 1.55 kW (For use on adequately wired 120V, dedicated circuit having 2-wire service with a separate ground wire. Appliance must be grounded for safe operation.)
- Amps @ 120 Volts = 13 Amps
- Always consult local and national electric codes.
- Microwave can stand alone on countertop or be built in with optional 30" or 27" Trim Kit (ordered by individual part number) which includes Bottom Duct Assembly - shipped in separate box.
- Allow 21" minimum clearance for 90° door swing.
- Minimum 20" deep oven cutout dimension is critical for proper installation for oven and faceplate to fit flush against cabinet front.
- Consult local building code, in the event that cutout opening may be required to be enclosed with sides, ceiling and rear partition.
- Full oven base of solid plywood or similar material required, capable of supporting 100 Lbs.

- Base must be level and front of cabinet square for proper operation.
- Grounded outlet should NOT be located in shaded area, as indicated, UNLESS cabinet depth is greater than 21".
- Can NOT be installed above any gas wall oven.
- Built-In Microwave is approved to be used in combination with any Frigidaire® Electric Single Wall Oven and/or Warmer Drawer. (Refer to model-specific Combination Installation Specification pages on web.)
- When used in combination with another Frigidaire® built-in product, a minimum clearance of 2-7/8" required from bottom of Built-In Microwave cutout to top edge of companion product's faceplate, leaving a 2" visible gap between both product faceplates.

Note: For planning purposes only. Refer to Product Installation Guide on the web at frigidaire.com for detailed instructions.

Optional Accessories

- 30" Stainless Steel Trim Kit - (PN# FFMOTK30LS).
- 27" Stainless Steel Trim Kit - (PN# FFMOTK27LS).
- 30" White Trim Kit - (PN# FFMOTK30LW).
- 27" White Trim Kit - (PN# FFMOTK27LW).
- 30" Black Trim Kit - (PN# FFMOTK30LB).
- 27" Black Trim Kit - (PN# FFMOTK27LB).



Use these dimensions and clearance instructions for planning purposes only. For detailed installation instructions, refer to installation guide, packed with product, or on the web at frigidaire.com.

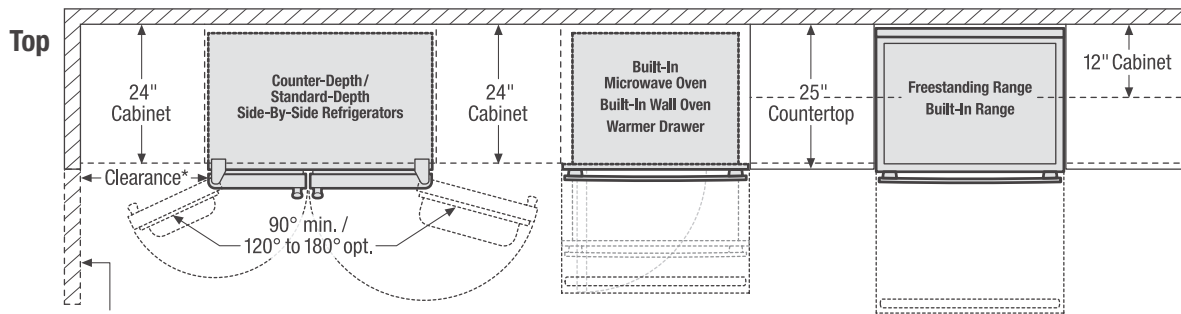
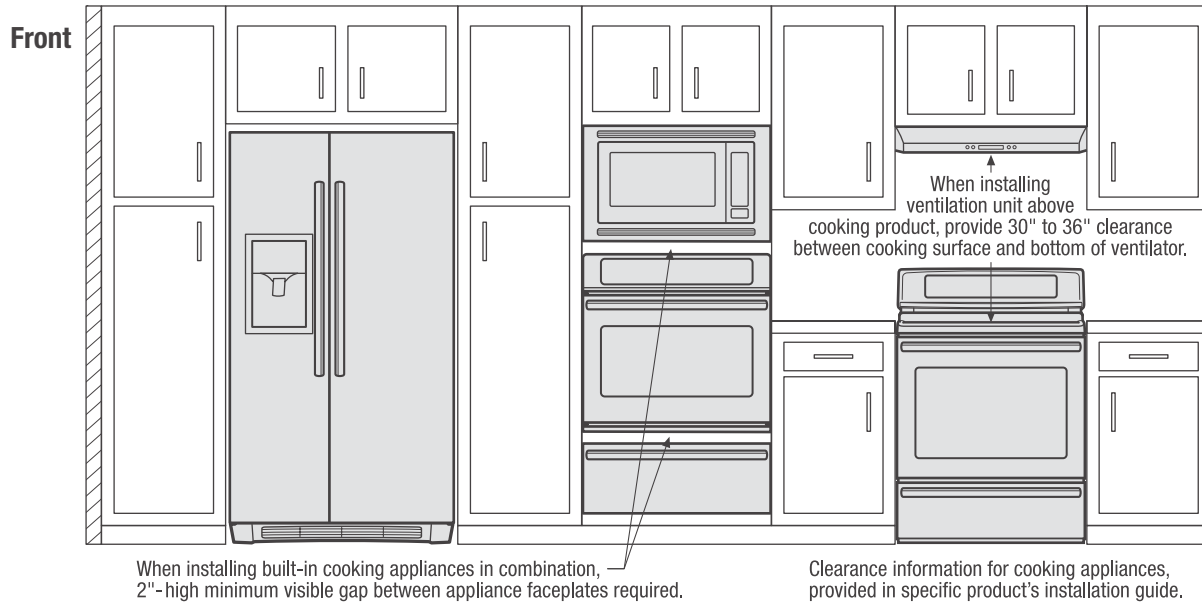

*When installing side-by-side refrigerator adjacent to wall, cabinet or another appliance that extends beyond front edge of unit, 20" minimum clearance recommended to allow for optimum 120° to 180° door swing, providing complete drawer/crisper access and removal. (Absolute 4-1/2" minimum clearance will ONLY allow for 90° door swing which will provide limited drawer/crisper access with restricted removal.)

When installing appliance with sliding drawer, swinging or drop-down door directly across from obstructions, provide sufficient clearance for drawer extension or door swings.

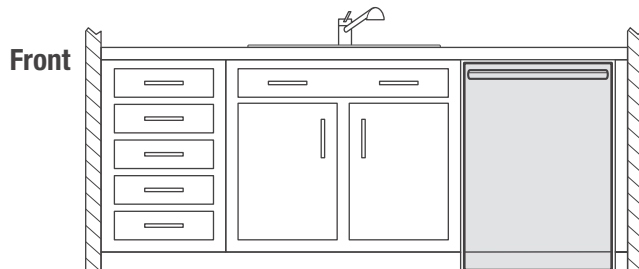
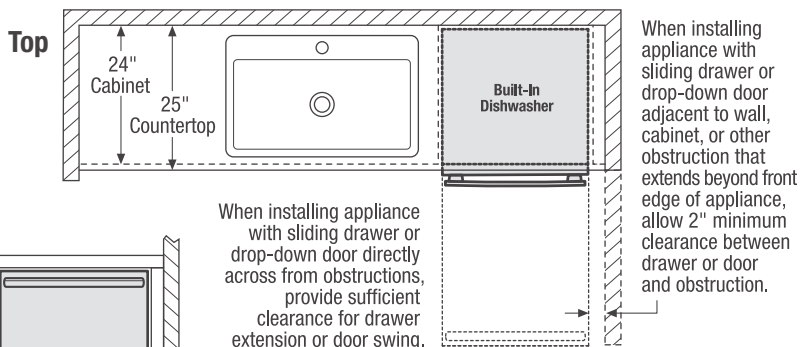

Use these dimensions and clearance instructions for planning purposes only. For detailed installation instructions, refer to installation guide, packed with product, or on the web at frigidaire.com.

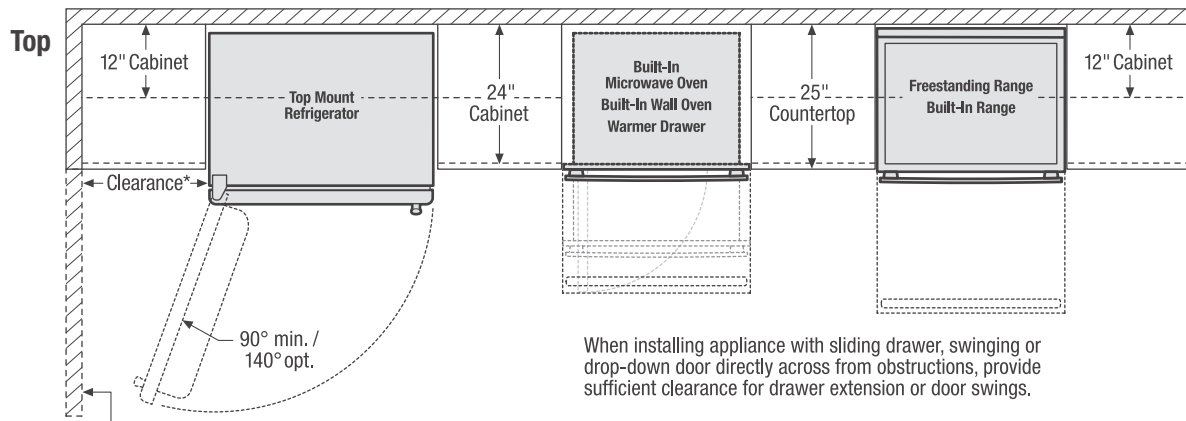
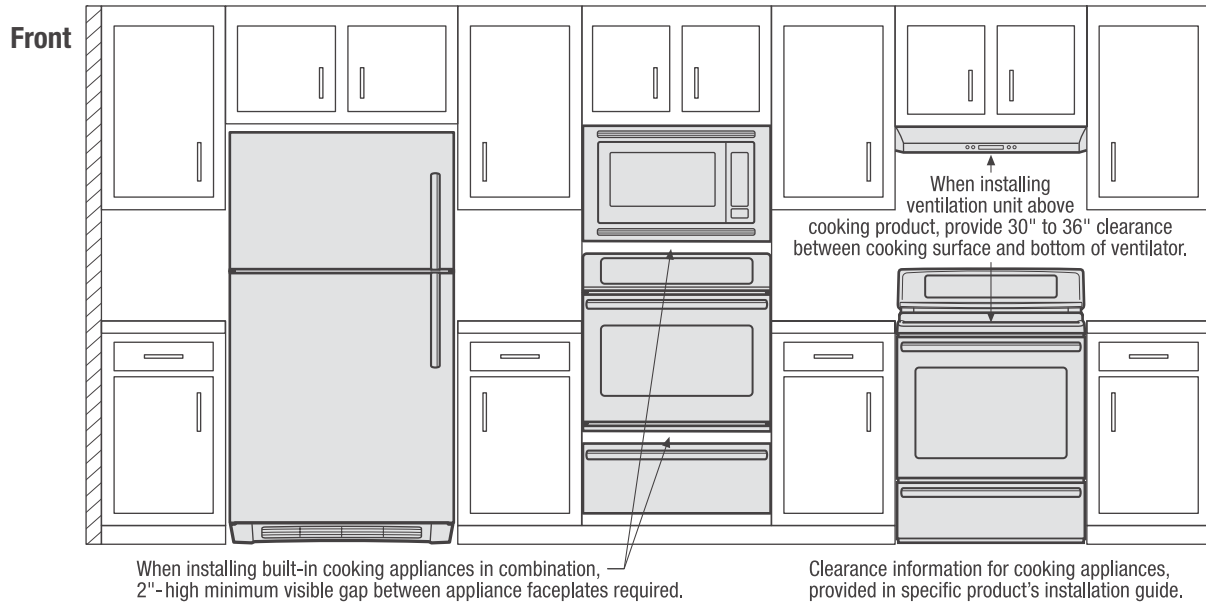

*When installing top mount refrigerator adjacent to wall, cabinet or other appliance that extends beyond front edge of unit, 20" minimum clearance recommended to allow for optimum 140° door swing, providing complete crisper access and removal. (Absolute 3" minimum clearance will ONLY allow for 90° door swing which will provide limited crisper access with restricted removal.)

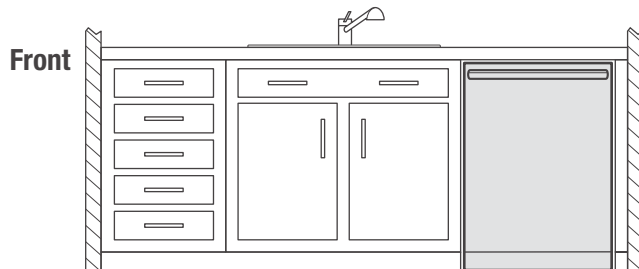
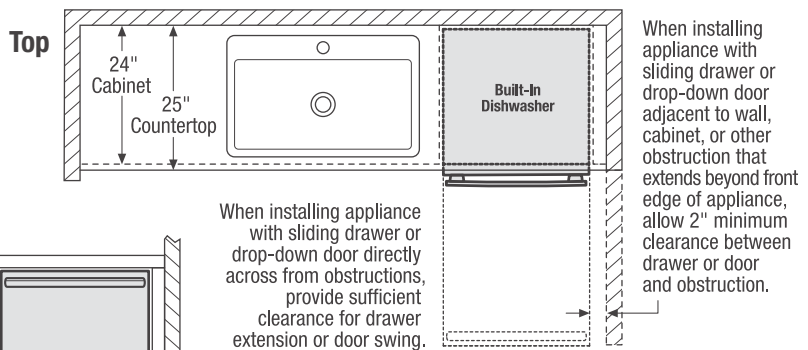

Use these dimensions and clearance instructions for planning purposes only. For detailed installation instructions, refer to installation guide, packed with product, or on the web at frigidaire.com.

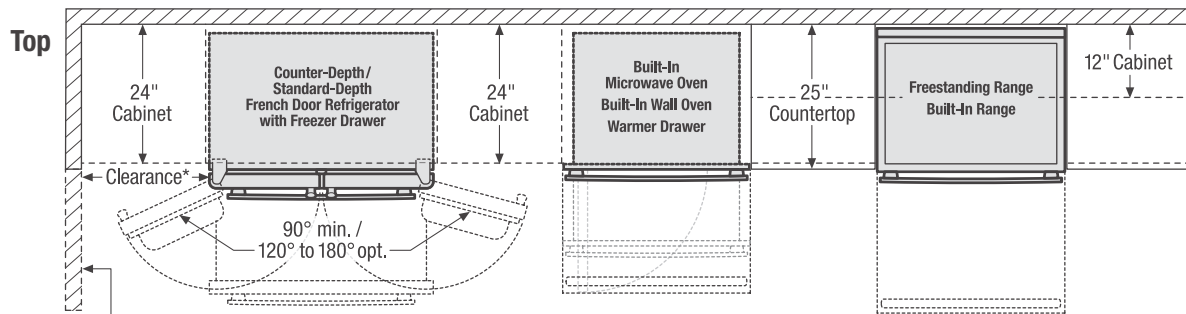
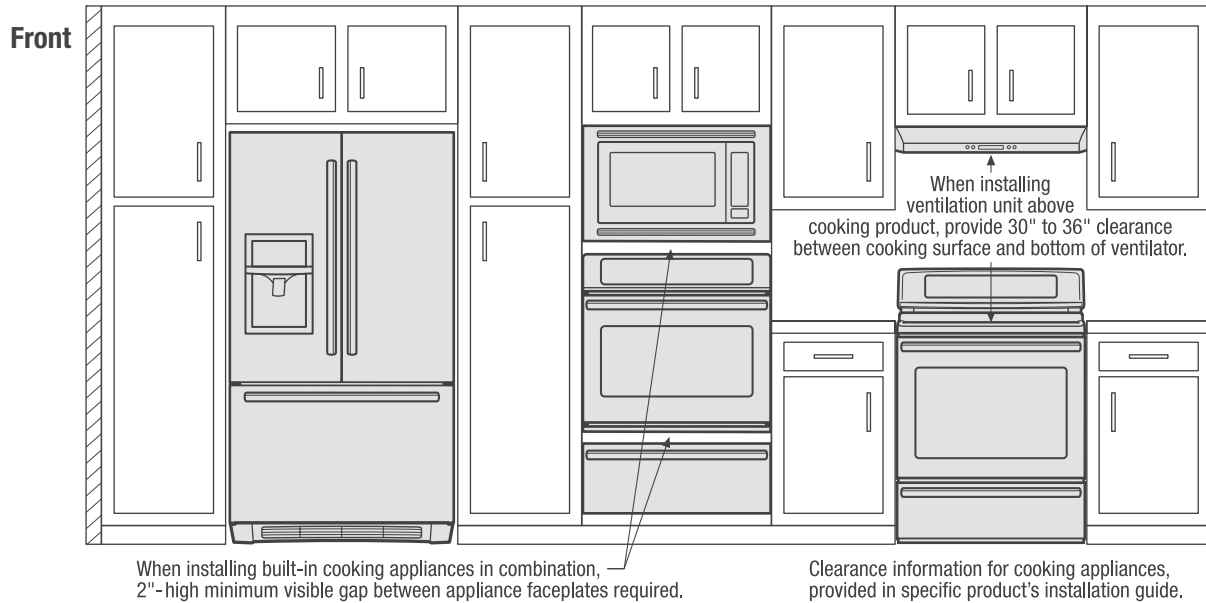

*When installing French door refrigerator adjacent to wall, cabinet or another appliance that extends beyond front edge of unit, 20" minimum clearance recommended to allow for optimum 120° to 180° door swing, providing complete drawer/crisper access and removal. (Absolute 4-1/2" minimum clearance will ONLY allow for 90° door swing which will provide limited drawer/crisper access with restricted removal.)

When installing appliance with sliding drawer, swinging or drop-down door directly across from obstructions, provide sufficient clearance for drawer extension or door swings.

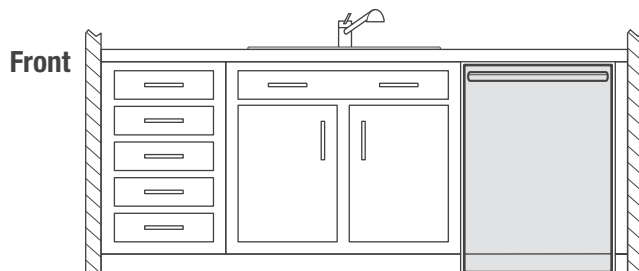
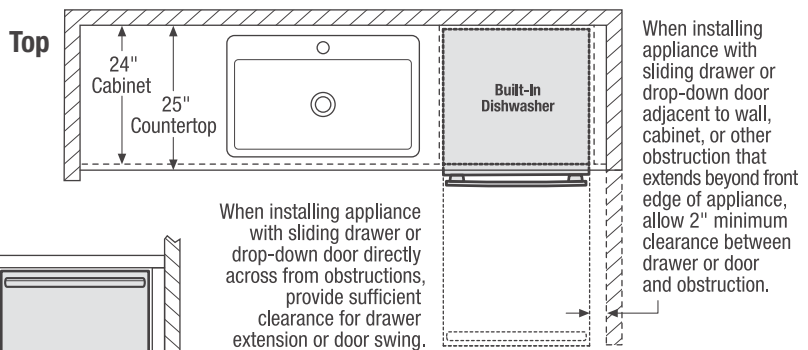

Use these dimensions and clearance instructions for planning purposes only. For detailed installation instructions, refer to installation guide, packed with product, or on the web at frigidaire.com.

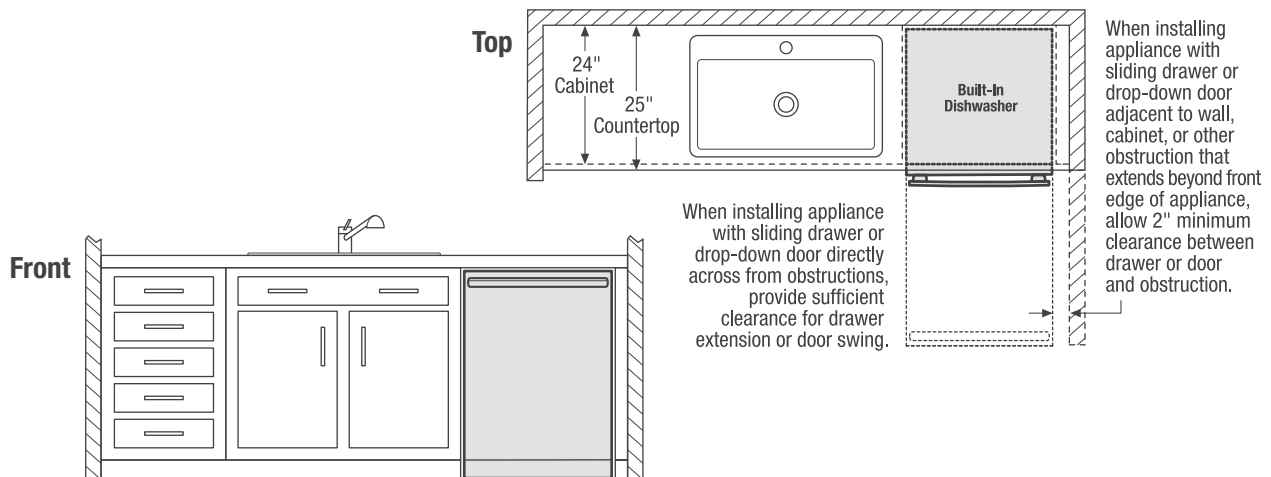
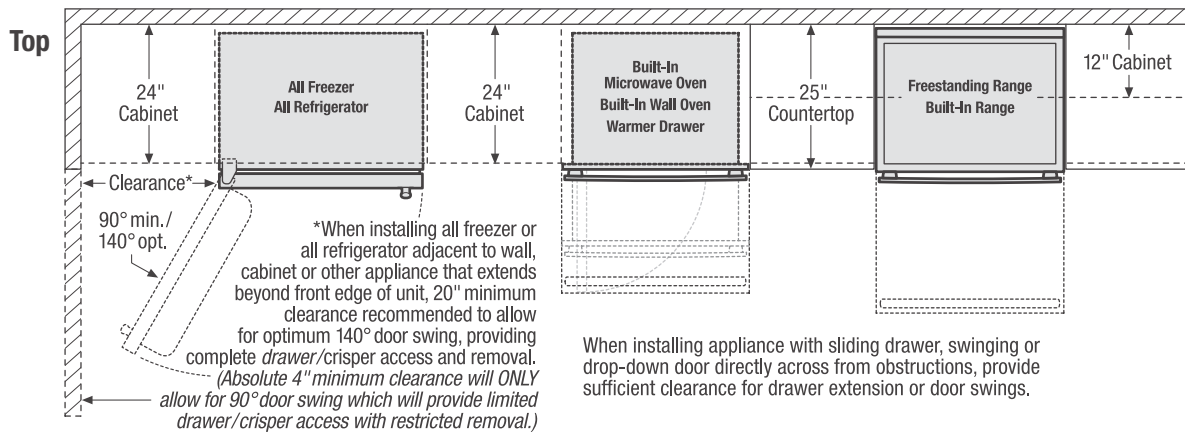
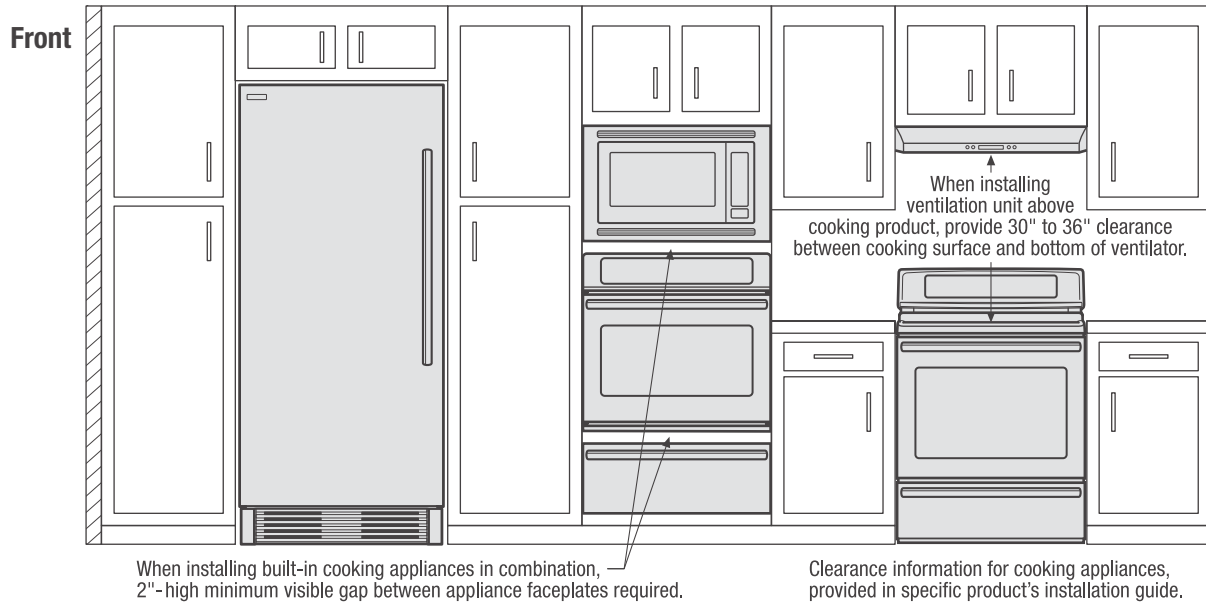



Overhead Hoods

FHWC3025M S/W/B

30" Under-Cabinet



Signature Features

2-Speed Fan

Effectively and quietly removes smoke, vapors and smells from the kitchen.

Dishwasher-Safe Filter

Dishwasher-safe for easy cleaning.

Cooking Surface Light

Provides ample illumination of the cooking surface.

Convertible Exhaust Duct Options¹

Ventilation is convertible to be either ducted outside, or recirculated inside requiring no ducting.

Features

Nominal Width	30"
Installation Type	Under-Cabinet
Style	Canopy
Controls	Rocker Switch
Air Discharge	Vertical or Horizontal
Air Delivery (CFM)	220
Blower Type	Fan
Sound Level (dBA)	67.9
Fan Speeds	2
Cooktop Light(s)	1 Incandescent (Not Included)
Dishwasher-Safe Filter(s)	Yes
Exhaust Duct	Convertible ¹
Duct Required	7" Round ² or 3-1/4" x 10"

Optional Accessories

Charcoal Filter	PN# 5304486302
7" Round Transition Duct	PN# 5304487139

Specifications

Product Dimensions -	
Height	5"
Width	30"
Depth	18-5/8"
Voltage Rating	120V / 60Hz / 15A
Connected Load (kW Rating) @ 120 Volts ³	.72
Amps @ 120 Volts	1.06
Shipping Weight (Approx.)	18 Lbs.
Sones Rating	5.8

¹ Ventilation is convertible to be either ducted outside, or recirculated inside requiring no ducting. (Recirculated option requires use of a cover.)

² 7" round duct requires use of optional transition duct.

³ For use on adequately wired 120V, dedicated circuit having 2-wire service with a separate ground wire. Appliance must be grounded for safe operation.

NOTE: Always consult local and national electric codes. Check local building codes for installation requirements, as they may vary per locale. Refer to Product Installation Guide for detailed installation instructions on the web at frigidaire.com.

Specifications subject to change.

Available in:



Stainless (S)

White (W)

Black (B)

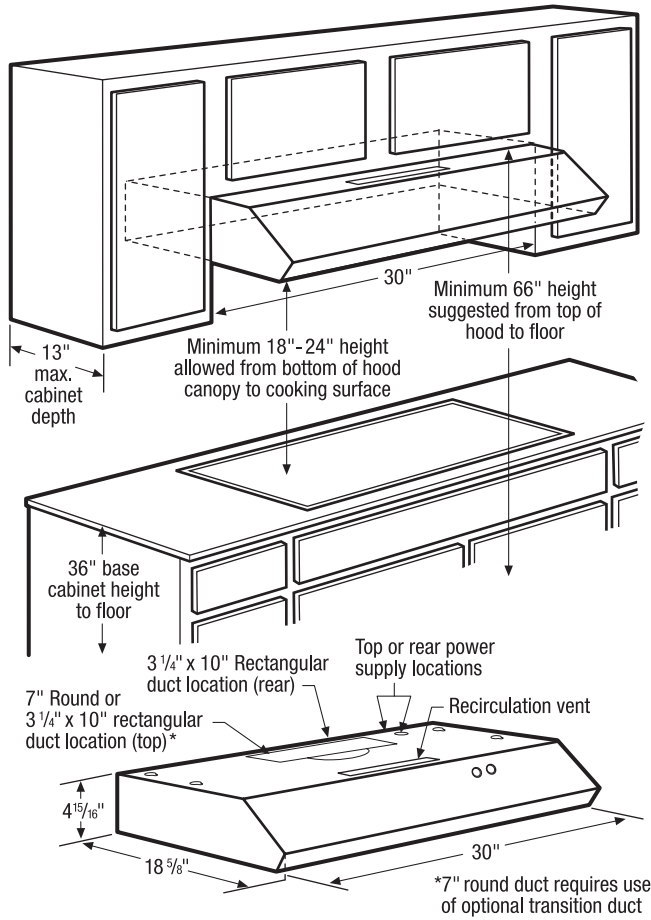

Exhaust Options

Vent hood can be vertically or horizontally ducted outside using round or rectangular duct; or recirculated inside with no ducting required.

For detailed duct preparation and installation specifications, refer to installation instructions on web.

Outside Vertical – 7" Round Duct Cabinet Bottom

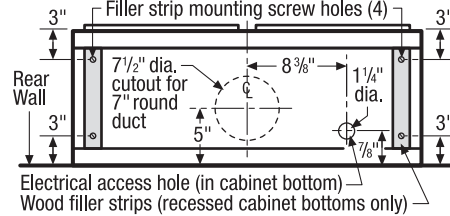

Outside Vertical – 3 1/4" x 10" Rectangular Duct Cabinet Bottom

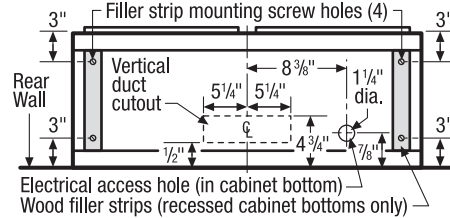

Outside Horizontal – 3 1/4" x 10" Rectangular Duct Cabinet Front

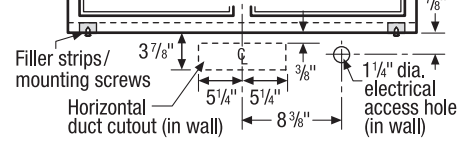

Under-Cabinet Hood Specifications

- Product Shipping Weight (Approx.) - 18 Lbs.
- Under-Cabinet Installation - can be ducted vertically or horizontally.
- Ventilation system can exhaust air outside, either vertically through roof or horizontally through wall. (Refer to Ducting Option Specifications for outside ventilation.). If ducting outside is not possible, the system can be alternately set to recirculate air inside, requiring use of recirculating kit, included with hood.
- Sones Rating - 5.8
- Voltage Rating - 120V / 60 Hz / 15 Amps
- Connected Load (kW Rating) @ 120 Volts = .72kW (For use on adequately wired 120V, dedicated circuit having 2-wire service with a separate ground wire. Appliance must be grounded for safe operation.)
- Amps @ 120 Volts = 1.06 Amps
- Always consult local and national electric codes. Check local building codes for installation requirements, as they may vary per locale.
- Makeup air systems may be required by local building codes when using ventilation systems greater than specified CFM of air movement. Specified CFM varies per locale.
- Connect vent hood with copper wire only. (For installation pre-wired with aluminum wiring, refer to Product Installation Guide on web for correct wiring procedure.)
- Locate vent hood away from strong draft areas, such as windows, doors or strong heating vents.
- Minimum 18" - 24" installation height allowed from bottom of hood canopy to cooking surface; minimum 66" height suggested from top of hood to floor.
- When installing vent hood under cabinets with recessed bottoms, two 2"-wide filler strips required with length and thickness determined by recess dimensions.

Ducting Option Specifications

- Vent system MUST terminate outside through roof or wall; do NOT terminate into attic or other enclosed area.
- Exhaust Duct Required - 3-1/4"x10" rectangular with 35' maximum vent length or 7" round with 50' maximum vent length. Refer to Product Installation Guide on web for calculations needed to determine total duct length.
- Installation of 7" Round Duct requires use of optional 7" Round Transition Duct (PN# 5304487139) and can only be vented vertically.
- To provide efficient performance, length of vent system and number of elbows should be kept to minimum. Flexible vent greatly reduces performance and is NOT recommended.
- Use 3-1/4"x10" rectangular metal vent only - rigid metal vent recommended; plastic or metal foil vent NOT recommended.
- For cold weather installation, additional backdraft damper and thermal break should be installed. Thermal break will minimize conduction of outside temperatures as part of the vent system with damper on cold air side of break, as close as possible to where vent system enters heated portion of house.
- Refer to Product Installation Guide on web for detailed vent system preparation instructions.

Note: For planning purposes only. Refer to Product Installation Guide on the web at frigidaire.com for detailed instructions.

Optional Accessories

- 7" Round Transition Duct - (PN# 5304487139).
- Charcoal Filter - (PN# 5304486302).

Accessories information available on the web at frigidaire.com



FFED3026T S/W/B

DROP-IN RANGE
30" ELECTRIC



AVAILABLE COLORS



Stainless



White



Black

PRODUCT DIMENSIONS

Height	26-1/2"
Width	30"
Depth	28-5/16"

MORE EASY-TO-USE FEATURES

Extra-Large Window

Check on the status of your dish without having to open the oven door.

Oven Rack Handles

Oven racks are designed with space for you to easily pull out the racks, even when wearing an oven mitt.

Large Capacity

Our large capacity oven gives you room to cook more dishes at once.

Built with American Pride

Designed, engineered and assembled in the U.S.A.

Auto Oven Shut-Off

As an extra safety measure, the oven will automatically shut off after 12 hours.

Hi/Lo Broil Options

Offers two-position broiling and variable temperature control for more control.

SIGNATURE FEATURES

One-Touch Self Clean

Your oven cleans itself — so you don't have to. Self clean options available in 2- and 3-hour cycles.

Quick Boil

Get meals on the table faster with our 3,000W element — water boils faster than the traditional setting.

Extra-Large Element

With our extra-large 12" element, you have more flexibility to fit larger pots and pans.

SpaceWise® Expandable Elements

Flexible elements expand to meet your cooking needs — big or small.

CERTIFICATIONS

A.D.A. - Compliant

When properly installed, this model is A.D.A.-qualified based on the United States Access Board's A.D.A./A.B.A. Accessibility Guidelines and the Department of Justice's 2010 A.D.A. Standards for Accessible Design.



ELEMENTS	SIZE	WATTS
Right Front	12"	2,700
Right Rear	6"	1,200
Left Front	6"/9"	1,400/3,000
Left Rear	7"	1,500

FFED3026T S/W/B DROP-IN RANGE

30" ELECTRIC

FRIGIDAIRE

FEATURES

Oven Control/Timing System	Ready-Select® Controls
Surface Type	Black Ceramic Glass (S), Color-Coordinated Ceramic Glass (W/B)
Window	Large
Exterior Door Finish	Stainless Steel (S), Color-Coordinated (W/B)
Handle Design	Stainless Steel (S), Color-Coordinated (W/B)
Exterior Finish (Side Panels)	Black (S), Color-Coordinated (W/B)
Convection System	
Oven Cleaning System	Self-Clean
Drawer Functionality	

OVEN CONTROLS

Bake	Yes
Broil	Variable
Add-a-Minute	
Delay Start	Yes
Self Clean	2, 3 Hours
Steam Clean	
Delay Clean	Yes
Kitchen Timer	Yes
Timed Cook Option	Yes
Auto Oven Shut-Off	12 Hours

COOKTOP FEATURES

Right Front Element (Watts)	12" - 2,700
Right Rear Element (Watts)	6" - 1,200
Left Front Element (Watts)	6/9" - 1,400/3,000
Left Rear Element (Watts)	7" - 1,500
Center Element (Watts)	
Hot Surface Indicator Light	Yes
Coil Cooktop/Drip Bowls	

OVEN FEATURES

Capacity (Cu.Ft.)	4.6
Oven Light	1 Halogen
Hidden Bake Element	
Rack Configuration	2 Handle Racks
Baking System	Even Baking Technology
Broiling System	Vari-Broil™ Hi/Lo
Bake Element / Broil Element (Watts)	2,750/3,400

OPTIONAL ACCESSORIES

Rear Filler Kit - White (W)/ Black (B)	(W) PN# 901193-9011 (B) PN# 901193-9010
Side Panel Kit - White (W)/ Black (B)	(W) PN# 903074-9011 (B) PN# 903074-9010
Backguard Kit - Stainless Steel (S)/ White (W)/Black (B)	(S) PN# 903046-9015 (W) PN# 903046-9011 (B) PN# 903046-9010
Side Trim Kit - White (W)/Black (B)	(W) PN# 903076-9011 (B) PN# 903076-9010
Bottom Trim Kit - White (W)/ Black (B)	(W) PN# 903068-9011 (B) PN# 903068-9010

CERTIFICATIONS

A.D.A. Compliant ¹	Yes
-------------------------------	-----

SPECIFICATIONS

Oven Interior (H x W x D)	17-1/2" x 24-1/8" x 18-3/4"
Power Supply Connection Location	Left Bottom Rear
Voltage Rating	240V / 208V / 60 Hz
Connected Load (kW Rating) @ 240/208 Volts ²	11.8/8.9
Amps @ 120 Volts	33/32.5
Minimum Circuit Required (Amps)	40
Shipping Weight (Approx.)	185 Lbs.

¹When properly installed, this model is A.D.A.-qualified based on the United States Access Board's A.D.A./A.B.A. Accessibility Guidelines and the Department of Justice's 2010 A.D.A. Standards for Accessible Design.

²Single phase 3- or 4-wire cable, 120/240 or 120/208 Volt, 60 Hertz AC only electrical supply with ground required on separate circuit fused on both sides of line.

PRODUCT DIMENSIONS

A - Height	26-1/2"
B - Width	30"
C - Depth	28-5/16"
Depth with Door Open 90°	47-9/16"

CABINET CUTOUT DIMENSIONS

Height	29"†
Width (Min./Max.)	29-15/16" / 30-1/16"*
Depth (Min./Max.)	21-3/4" / 22-1/8"***

†27-1/2" min. if additional front cabinet filler panel is required (refer to product installation guide on web for filler panel details).

*Cutout and countertop cutout width should match.

**24" with optional backguard installed.

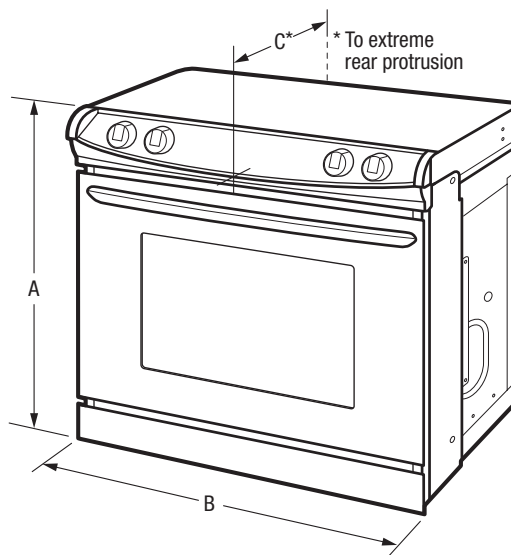

FRIGIDAIRE

USA • 10200 David Taylor Drive • Charlotte, NC 28262 • 1-800-FRIGIDAIRE • frigidare.com
CANADA • 5855 Terry Fox Way • Mississauga, ON L5V 3E4 • 1-800-265-8352 • frigidare.ca



Note: For planning purposes only. Always consult local and national electric, gas and plumbing codes. Refer to Product Installation Guide for detailed installation instructions on the web at frigidare.com.

Specifications subject to change. Accessories information available on the web at frigidare.com

FFED3026T 07/17
© 2017 Electrolux Home Products, Inc.

FFED3026T S/W/B DROP-IN RANGE

30" ELECTRIC

FRIGIDAIRE

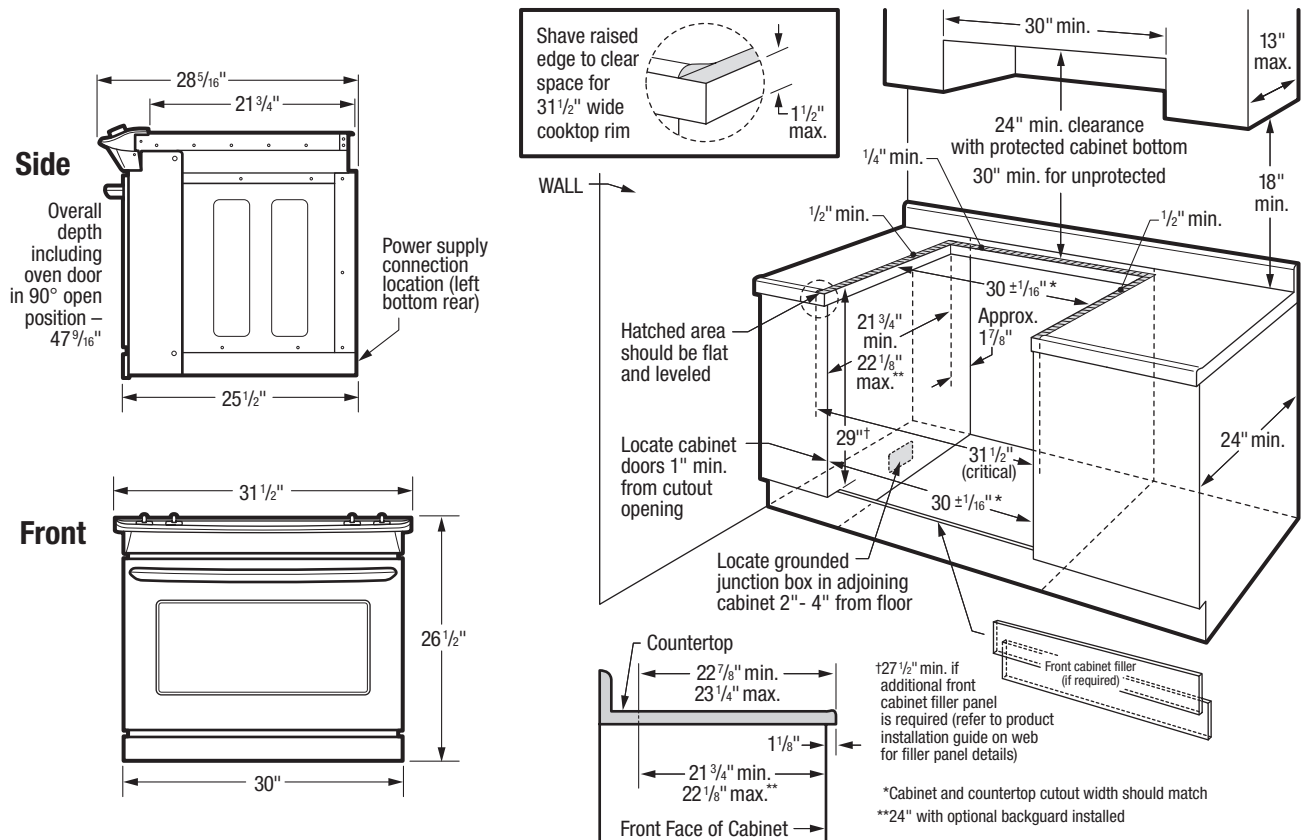

INSTALLATION SPECIFICATIONS

- Product Shipping Weight (approx.) - 185 Lbs.
- Single phase 3- or 4-wire cable, 120/240 or 120/208 Volt, 60 Hertz, fused on both sides of line with ground. (If local code permits, range may be connected by hard-wiring or by means of power supply cord kit.)
- Connected Load (kW Rating) @ 240/208 Volts = 11.8/8.9 kW
- Amps @ 240/208 Volts = 33/32.5 Amps
- Recommended Circuit Breaker - 40 Amps
- Always consult local and national electric codes.
- Make sure wall coverings around range can withstand heat generated by range.
- Linoleum or any other synthetic floor covering located beneath range, must be capable of withstanding minimum heat of 90°F above room temperature without shrinking, warping or discoloring. Insulating pad or 1/4"-thick plywood required between range and a carpeted floor.
- When installing optional Backguard Kit, cutout depth of 21-3/4" minimum/ 22-1/8" maximum needs increased to 24".
- Overhead cabinetry should not exceed a 13" maximum depth.
- Absolute minimum horizontal distance between overhead cabinets installed to either side of appliance must be no less than maximum width of appliance.
- Allow 24" minimum clearance between rangetop and bottom of cabinet when bottom of wood or metal cabinet is protected by not less than 1/4" flame-retardant millboard covered with not less than No. 28 MSG sheet steel, 0.015" stainless steel, 0.024" aluminum or 0.020" copper. Allow 30" minimum clearance when cabinet is unprotected.
- To reduce risk of fire when using overhead cabinetry, install range hood that projects horizontally a recommended minimum of 5" beyond bottom of cabinets.

COUNTERTOP PREPARATION

Rangetop's side flanges overlap countertop cutout edges - for detailed preparation instructions, refer to product installation guide on the web.

- Flat Square-Finish Countertops - require no preparation since rangetop's flange lays directly on countertop edge.
- Formed Front-Edged Countertops - require front molded edge to be shaved flat 3/4" from each front corner of opening.
- Tile Countertops - may need trim cut back 3/4" from each front corner of opening and/or rounded edge flattened.
- For existing cutout width greater than 30-1/16" reduce the 3/4" overlap dimension; for cutout width of 29", replace actual side trim panels with smaller side trim panels, available with optional Side Trim Kit (refer to detailed kit installation instructions).

OPTIONAL ACCESSORIES

- Rear Filler Kit: White - (PN# 901193-9011), Black - (PN# 901193-9010).
- Side Panel Kit: White - (PN# 903074-9011), Black - (PN# 903074-9010).
- Backguard Kit: Stainless Steel - (PN# 903046-901S), White - (PN# 903046-9011), Black - (PN# 903046-9010).
- Side Trim Kit: White - (PN# 903076-9011), Black - (PN# 903076-9010).
- Bottom Trim Kit: White - (PN# 903068-9011), Black - (PN# 903068-9010).

Note: For planning purposes only. Always consult local and national electric, gas and plumbing codes. Refer to Product Installation Guide for detailed installation instructions on the web at frigidaire.com.

Specifications subject to change. Accessories information available on the web at frigidaire.com



FRIGIDAIRE

USA • 10200 David Taylor Drive • Charlotte, NC 28262 • 1-800-FRIGIDAIRE • frigidaire.com
CANADA • 5855 Terry Fox Way • Mississauga, ON L5V 3E4 • 1-800-265-8352 • frigidaire.ca

FFED3026T 07/17

© 2017 Electrolux Home Products, Inc.

Freestanding Ranges

FFEF3054T D/S/W/B



30" Electric

Product Dimensions

Height (Max.)	47"
Width	29-7/8"
Depth (Including Handle)	28-1/2"

More Easy-To-Use Features

SpaceWise® Expandable Elements

Flexible elements expand to meet your cooking needs — big or small.

Store-More™ Storage Drawer

With the Store-More™ Storage Drawer, you will have extra space to store your cookware.

Large Capacity

Our large capacity oven gives you room to cook more dishes at once.

Built with American Pride

Designed, engineered and assembled in the U.S.A.

Color-Coordinated Oven Door with Extra-Large Window

Our extra-large oven window makes it easier to check on the status of your dish without having to open the oven door.

Timed Cook Option

Lets you set the oven to begin cooking at a predetermined time.

Electronic Kitchen Timer

Times up to 12 hours.

Signature Features

One-Touch Self Clean

Your oven cleans itself - so you don't have to. Self clean options available in 2- and 3-hour cycles.

Quick Boil

Get meals on the table faster with our 3,000W element — water boils faster than the traditional setting.

Keep Warm Zone

Keep food warm until everything — and everyone — is ready.

Extra-Large Element

With our extra-large 12" element, you have more flexibility to fit larger pots and pans.

Available in:



Elements	Size	Watts
Right Front	12"	2,700
Right Rear	6"	1,200
Left Front	6" / 9" Expandable	1,400 / 3,000
Left Rear	6"	1,200
Center	Keep Warm Zone	100

Features	
Oven Control/Timing System	Ready-Select® Controls
Surface Type	Black Ceramic Glass
Window	Extra-Large
Exterior Door Finish	Black Stainless (D), Stainless (S) Color-Coordinated (W/B)
Handle Design	Black Stainless (D), Stainless (S) Color-Coordinated (W/B)
Exterior Finish (Side Panels)	Black (D/S), Color-Coordinated (W/B)
Convection System	
Oven Cleaning System	Self Clean
Drawer Functionality	Storage
Oven Controls	
Bake	Yes
Broil	Variable (High/Low)
Add-a-Minute	
Delay Start	
Self-Clean	2, 3 Hour
Quick Clean Option	Yes
Delay Clean	Yes
Kitchen Timer	Yes
Timed Cook Option	Yes
Auto Oven Shut-Off	12 Hours
Oven Lock-Out	Yes
Cooktop Features	
Right Front Element (Watts)	12" - 2,700
Right Rear Element (Watts)	6" - 1,200
Left Front Element (Watts)	SpaceWise® Expandable 6"/9" - 1,400/3,000
Left Rear Element (Watts)	6" - 1,200
Center Element (Watts)	Keep Warm Zone - 100
Hot Surface Indicator Light	Yes
Element "On" Indicator Light	Yes
Coil Cooktop/Drip Bowls	
Oven Features	
Capacity (Cu. Ft.)	5.3
Oven Light	1
Hidden Bake Element	
Rack Configuration	2 Standard
Baking System	Even Baking Technology
Broiling System	Vari-Broil™ Hi/Lo
Bake Element/Broil Element (Watts)	2,600/3,000
Specifications	
Oven Interior (H x W x D)	19-3/4" x 24-3/8" x 19-1/8"
Power Supply Connection Location	Middle Bottom Rear
Voltage Rating	240V/208V/60Hz
Connected Load (kW Rating) @ 240/208 Volts	11.5/8.5
Minimum Circuit Required (Amps)	40
Shipping Weight (Approx.)	170 Lbs.

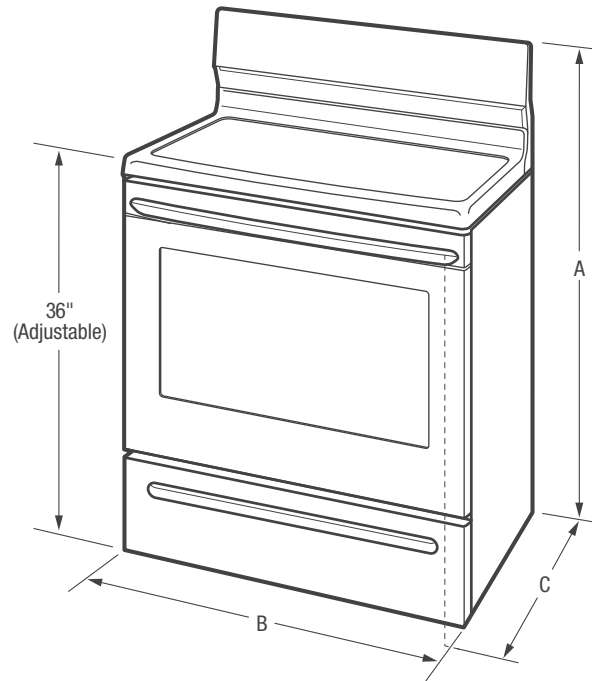

NOTE: For planning purposes only. Always consult local and national electric codes. Refer to Product Installation Guide for detailed installation instructions on the web at frigidaire.com.



Product Dimensions	
A - Height (Max.)	47"
B - Width	29-7/8"
C - Depth (Including Handle)	28-1/2"
Depth with Door Open 90°	48-5/8"

Cabinet Cutout Dimensions	
Height (Standard)	36"
Width (Min.)	30"
Depth (Min.)	24"

Accessories information available on the web at frigidaire.com

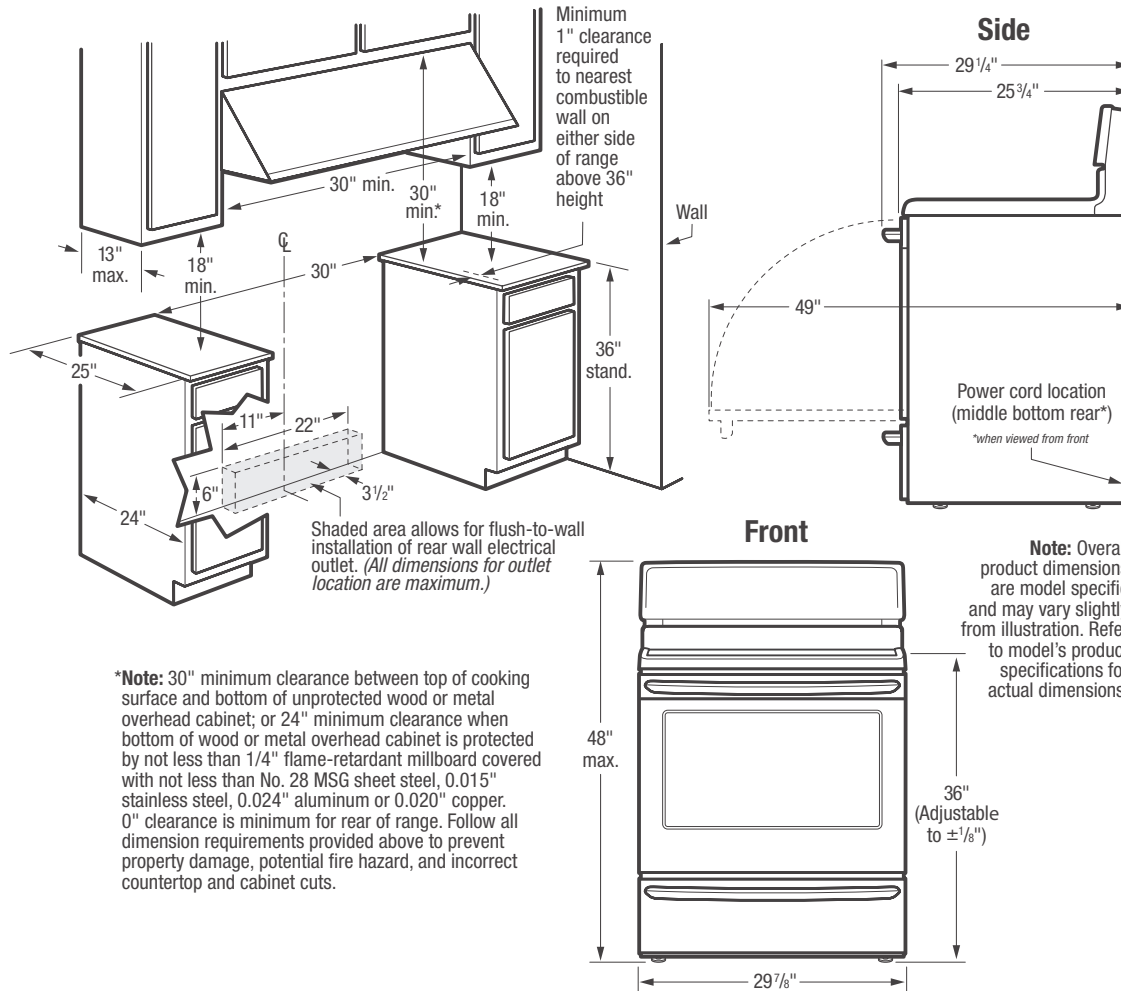

Freestanding Range Specifications

- Product Shipping Weight (approx.) - 170 Lbs.
- Single phase 3- or 4-wire cable, 120/240 or 120/208 Volt, 60 Hertz, fused on both sides of line with ground.
- Connected Load (kW Rating) @ 240/208 Volts = 11.5/8.5kW
- Recommended Circuit Breaker - 40 Amps
- Always consult local and national electric codes.
- Make sure wall coverings around range can withstand heat generated by range.
- Floor beneath range MUST be solid and level.
- Overhead cabinetry should not exceed a 13" maximum depth.
- Absolute minimum horizontal distance between overhead cabinets installed to either side of appliance must be no less than maximum width of appliance.
- Range can be installed flush to wall with 0" minimum rear clearance.
- Minimum 1" clearance required from edge of rangetop to nearest combustible wall on either side of range above 36" height.

- Allow 30" minimum clearance between top of cooking surface and bottom of unprotected wood or metal overhead cabinet; or 24" minimum clearance when bottom of wood or metal overhead cabinet is protected by not less than 1/4" flame retardant millboard covered with not less than No. 28 MSG sheet steel, 0.015" stainless steel, 0.024" aluminum or 0.020" copper.
- To reduce risk of fire when using overhead cabinetry, install range hood that projects horizontally a recommended minimum of 5" beyond bottom of cabinets.
- Follow all dimension requirements provided to prevent property damage, potential fire hazard, and incorrect countertop and cabinet cuts.

Note: For planning purposes only. Refer to Product Installation Guide on the web at frigidaire.com for detailed instructions.



Top Mount Refrigerators

FFHT2032T S/M/P/E

20.4 Cu. Ft. Top Mount



Product Dimensions

Height (Including Hinges & Rollers)	69"
Width	29-5/8"
Depth (Including Door)	32"

More Easy-To-Use Features

Bright LED Lighting

Find food faster with bright LED lighting.

Full-Width Wire Freezer Shelf

Gives you a way to organize items in your freezer better so you can find food quickly.

Reversible Door

Door can be installed to open left or right based on your needs.

Clear Dairy Bin

Keep foods like butter, cheese and yogurt organized.



ENERGY STAR® Most Efficient

Available in:



¹Compared to 18 cu. ft. top mount refrigerators.

Signature Features

Same Width. More Capacity.¹

With a 20 cu. ft. top freezer refrigerator, you can have a refrigerator that fits the same space as an 18 cu. ft. top freezer refrigerator, but get more capacity.

Store-More™ Humidity-Controlled Crisper Drawers

Keep your fruits and vegetables fresh in our humidity-controlled crisper drawers.

Store-More™ Gallon Door Shelf

Door storage gives you room for larger items like a gallon of milk.

SpillSafe® Shelves

Designed to keep spills contained, making cleanup a breeze.

Features	
Door Design	UltraSoft™
Door Handle Design	Stainless Steel (S), Color-Coordinated (M/P/E)
Cabinet Finish (Textured)	Black (S), Color-Coordinated (M/P/E)
Door Stops	Yes
Door Hinge Covers	Black (S), Color-Coordinated (M/P/E)
Door Reverse Option	Yes
Rollers - Front/Rear	Adjustable / Yes
Sound Package	
Toe Grille	Black (S), Color-Coordinated (M/P/E)
Refrigerator Features	
Interior Lighting	LED
Refrigerator Shelves	2 Full-Width SpillSafe®
Deli Drawer	1 Half-Width
Wine/Can Rack	
Store-More™ Crisper Drawers	2 Clear
Humidity Controls	2
Dairy Compartment	Clear Dairy Door
Door Bins	3 Full-Width White
Door Racks	
Non-Slip Bin Liner	
Tall Bottle Retainers	
Gallon Door Storage	1
Freezer Features	
Door Bins	2 Full-Width Clear
Door Racks	
Freezer Shelves	1 Full-Width Wire
Factory Ice Maker w/ Large Ice Bin	Optional (PN# IM115)
Lighting	
Certifications	
ENERGY STAR® Most Efficient	Yes
Specifications	
Total Capacity (Cu. Ft.)	20.4
Refrigerator Capacity (Cu. Ft.)	15.3
Freezer Capacity (Cu. Ft.)	5.1
Power Supply Connection Location	Right Bottom Rear
Water Inlet Connection Location	Bottom Right
Voltage Rating	120V / 60Hz
Connected Load (kW Rating) @ 120 Volts ¹	0.72
Amps @ 120 Volts	6.0
Minimum Circuit Required (Amps)	15
Shipping Weight (Approx.)	220 Lbs.

¹For use on adequately wired 120V, dedicated circuit having 2-wire service with a separate ground wire. Appliance must be grounded for safe operation.

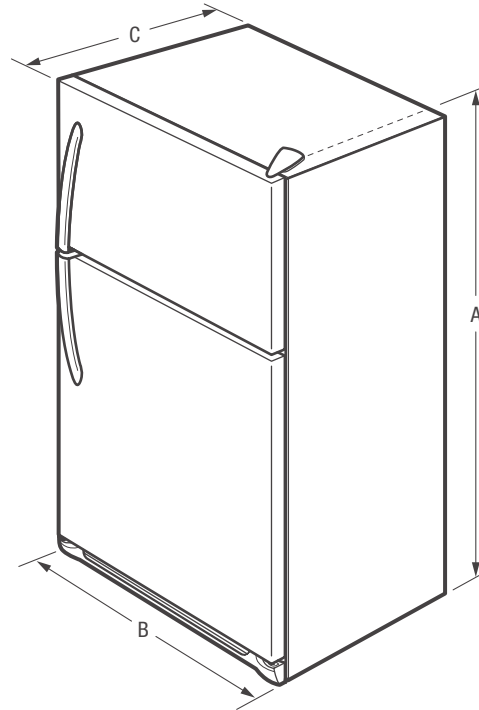

NOTE: For planning purposes only. Always consult local and national electric and plumbing codes. Refer to Product Installation Guide for detailed installation instructions on the web at frigidaire.com.



Product Dimensions	
A - Height (Incl. Hinges & Rollers)	69"
B - Width	29-5/8"
C - Depth (Incl. Door)	32"
Depth with Door Open 90°	60"

Accessories information available on the web at frigidaire.com

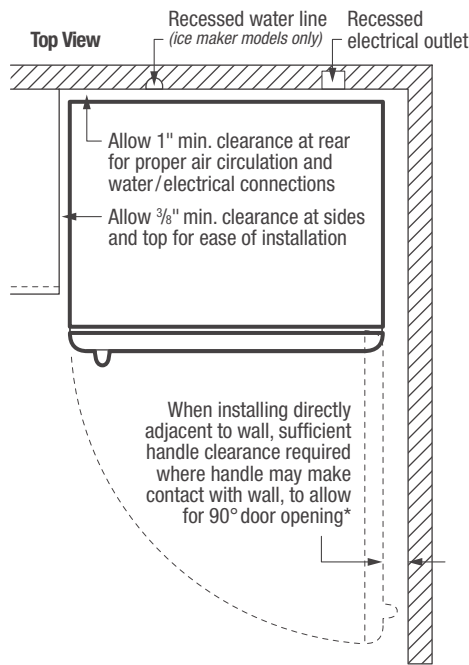

* When installing refrigerator adjacent to wall, cabinet or other appliance that extends beyond front edge of unit, 20" minimum clearance recommended to allow for optimum 140° door swing, providing complete crisper access and removal. (Absolute 3" minimum clearance will ONLY allow for 90° door swing which will provide limited crisper access with restricted removal.)

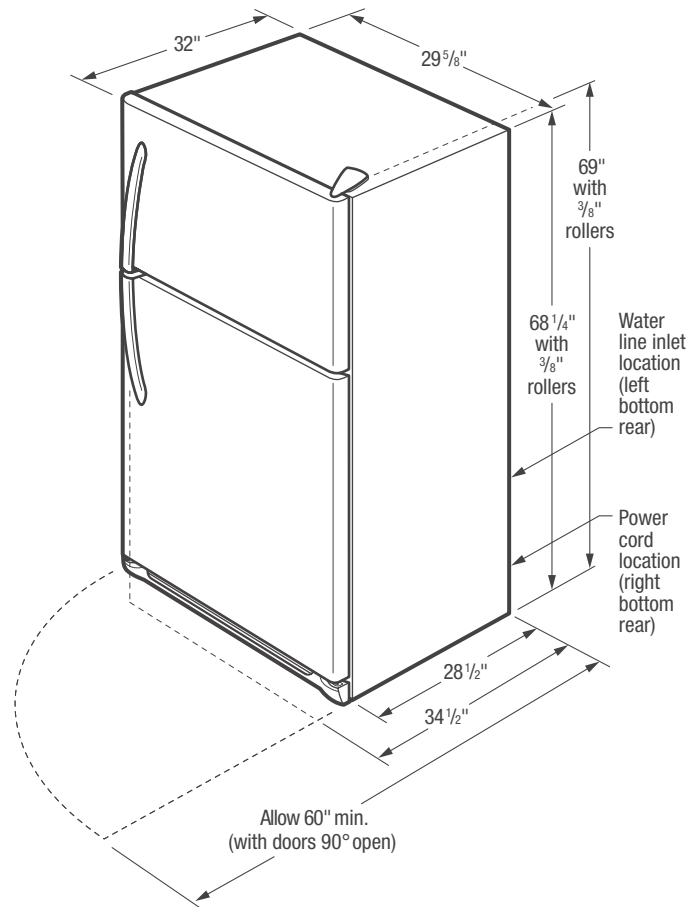

Top Mount Refrigerator Specifications

- Product Shipping Weight (approx.) - 220 Lbs.
- An electrical supply with grounded three-prong receptacle is required. The power supply circuit must be installed in accordance with current edition of National Electrical Code (NFPA 70) and local codes & ordinances.
- Voltage Rating - 120V/60 Hz
- Connected Load (kW Rating) @ 120 Volts = 0.72 kW
- Amps @ 120 Volts = 6.0 Amps
- Always consult local and national electric & plumbing codes.
- Floor should be level surface of hard material, capable of supporting fully loaded refrigerator.
- Minimum 3/8" clearance required for sides and top of refrigerator with 1" clearance at rear to allow for ease of installation, proper air circulation, and plumbing/electrical connections.
- When installing refrigerator adjacent to wall, cabinet or other appliance that extends beyond front edge of unit, 20" minimum clearance recommended to allow for optimum 140° door swing, providing complete crisper access and removal. (Absolute 3" minimum clearance will ONLY allow for 90° door swing which will provide limited crisper access with restricted removal.)

- To ensure optimum performance, do not install in areas where temperature drops below 55° F or rises above 110° F and avoid installing in direct sunlight or close proximity to range, dishwasher or other heat source.
- For proper ventilation, front grille MUST remain unobstructed.
- Recess electrical outlet when possible.
- Optional Ice Maker Kit (PN# IM115) available for installation in ice maker-ready models only.
- Water recess on rear wall recommended to prevent water line damage.
- Water Pressure - Cold water line must provide between 30 and 100 pounds per square inch (psi).
- Copper tubing with 1/4" O.D. recommended for water supply line with length equal to distance from rear of unit to household water supply line plus 7 additional feet. Optional Water Supply Installation Kits available.
- Adjustable front rollers to assist with door alignment.

Note: For planning purposes only. Refer to Product Installation Guide on the web at frigidaire.com for detailed instructions.

Optional Accessories

- Ice Maker Kit - (PN# IM115).

Whirlpool® 7.0 cu. ft. Cabrio® High-Efficiency Electric Dryer

 [Send Page to Printer](#)  [Close Window](#)



WED7000DW

AVAILABLE COLORS

- [White](#)
[Model: WED7000DW](#)

DIMENSIONS

Height 40 1/4 Inches
Depth 28 1/4 Inches
Width 29 Inches
Dimensions shown are for
planning purposes only. For
complete information, see
Installation Instructions packed
with product.

ELECTRICAL

30 Amps Amps. 60 Hz. 240 V.

KEY FEATURES

- Advanced Moisture Sensing
- Intuitive Touch Controls with Memory
- Estimated Time Remaining LED Display
- 7.0 Cu. Ft. Capacity
- Sanitize Cycle
- Designed, Engineered and Assembled in the U.S.A.

Whirlpool® 4.8 cu. ft. Cabrio® High-Efficiency Top Load Washer with Industry-Exclusive ColorLast™ Option

 [Send Page to Printer](#)  [Close Window](#)



WTW7000DW



AVAILABLE COLORS

- [White](#)
[Model: WTW7000DW](#)

DIMENSIONS

Height 40 1/4 Inches
Depth 28 Inches
Width 27 1/2 Inches

Dimensions shown are for planning purposes only. For complete information, see Installation Instructions packed with product.

ELECTRICAL

15 Amps Amps. 120 V.

KEY FEATURES

- Intuitive Touch Controls with Memory
- Adaptive Wash Technology with Active Bloom™ Wash Action
- ColorLast™ Option
- Low-Profile Impeller
- Estimated Time Remaining LED Display
- Smooth Wave Stainless Steel Wash Basket
- ENERGY STAR® Qualified
- Presoak Option

Top Mount Refrigerators

FFHT1821T S/W/B

18 Cu. Ft. Top Mount



Product Dimensions

Height (Including Hinges & Rollers)	66-1/8"
Width	30"
Depth (Including Door)	30-1/8"

More Easy-To-Use Features

Clear Dairy Bin

Keep foods like butter, cheese and yogurt organized.

A.D.A. - Compliant¹

With accessible shelving, and controls that are positioned within arm's reach and allow one-hand operation, our top-freezer refrigerator is A.D.A.-Compliant.



ENERGY STAR®

Available in:



Stainless (S)



White (W)



Black (B)

¹When properly installed, this model is A.D.A.-qualified based on the United States Access Board's A.D.A./A.B.A. Accessibility Guidelines and the Department of Justice's 2010 A.D.A. Standards for Accessible Design.

Signature Features

Store-More™ Humidity-Controlled Crisper Drawers

Keep your fruits and vegetables fresh in our humidity-controlled crisper drawers.

Store-More™ Gallon Door Shelf

Door storage gives you room for larger items like a gallon of milk.

Full-Width Wire Freezer Shelf

Gives you a way to organize items in your freezer better so you can find food quickly.

Reversible Door

Door can be installed to open left or right based on your needs.

Features	
Door Design	UltraSoft™
Door Handle Design	Stainless Steel (S), Color-Coordinated (W/B)
Cabinet Finish (Textured)	Black (S), Color-Coordinated (W/B)
Door Stops	Yes
Door Hinge Covers	Black (S), Color-Coordinated (W/B)
Door Reverse Option	Yes
Rollers - Front/Rear	Fixed/Yes
Sound Package	
Toe Grille	Black (S), Color-Coordinated (W/B)
Refrigerator Features	
Interior Lighting	Standard
Refrigerator Shelves	2 Full-Width Glass
Deli Drawer	1 Half-Width
Wine/Can Rack	
Store-More™ Crisper Drawers	2 Clear
Humidity Controls	2
Dairy Compartment	Clear Dairy Door
Door Bins	
Door Racks	3 Full-Width White
Non-Slip Bin Liner	
Tall Bottle Retainers	
Gallon Door Storage	1
Freezer Features	
Door Bins	
Door Racks	2 Full-Width White
Freezer Shelves	1 Full-Width Wire
Factory Ice Maker w/ Large Ice Bin	Optional (PN# IM116)
Lighting	
Certifications	
A.D.A. - Compliant ¹	Yes
ENERGY STAR®	Yes
Specifications	
Total Capacity (Cu. Ft.)	18.0
Refrigerator Capacity (Cu. Ft.)	14.1
Freezer Capacity (Cu. Ft.)	3.9
Power Supply Connection Location	Right Bottom Rear
Water Inlet Connection Location	Bottom Right
Voltage Rating	120V / 60Hz
Connected Load (kW Rating) @ 120 Volts ²	0.72
Amps @ 120 Volts	6.0
Minimum Circuit Required (Amps)	15
Shipping Weight (Approx.)	205 Lbs.

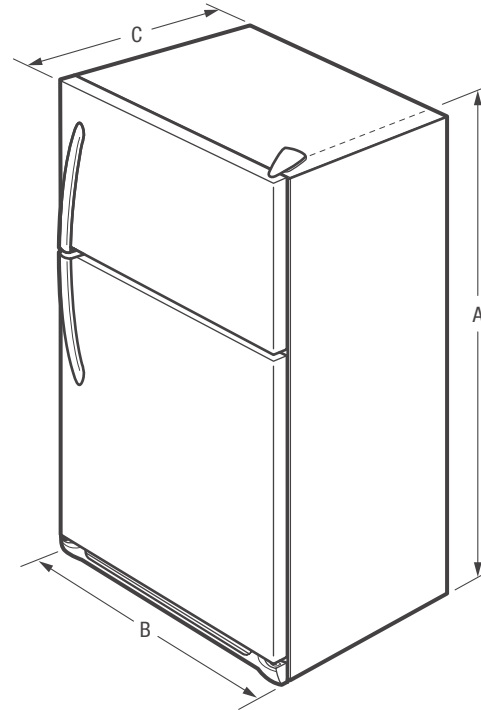

¹When properly installed, this model is A.D.A.-qualified based on the United States Access Board's A.D.A./A.B.A. Accessibility Guidelines and the Department of Justice's 2010 A.D.A. Standards for Accessible Design.

²For use on adequately wired 120V, dedicated circuit having 2-wire service with a separate ground wire. Appliance must be grounded for safe operation.

NOTE: For planning purposes only. Always consult local and national electric and plumbing codes. Refer to Product Installation Guide for detailed installation instructions on the web at frigidaire.com.



Product Dimensions	
A - Height (Incl. Hinges & Rollers)	66-1/8"
B - Width	30"
C - Depth (Incl. Door)	30-1/8"
Depth with Door Open 90°	58-1/2"

Accessories information available on the web at frigidaire.com

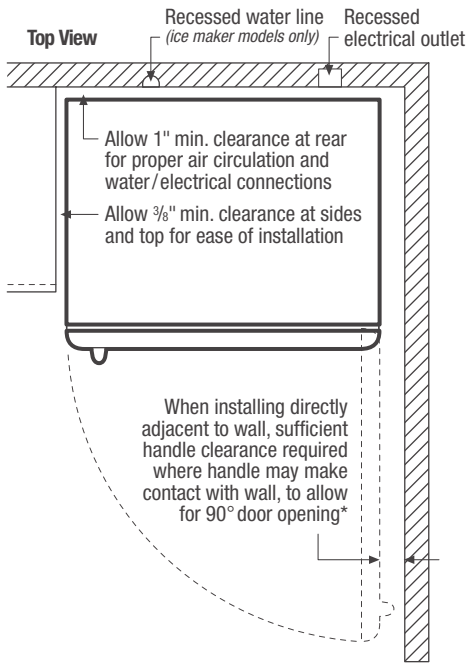

When installing directly adjacent to wall, sufficient handle clearance required where handle may make contact with wall, to allow for 90° door opening*

* When installing refrigerator adjacent to wall, cabinet or other appliance that extends beyond front edge of unit, 20" minimum clearance recommended to allow for optimum 140° door swing, providing complete crisper access and removal. (Absolute 3" minimum clearance will ONLY allow for 90° door swing which will provide limited crisper access with restricted removal.)

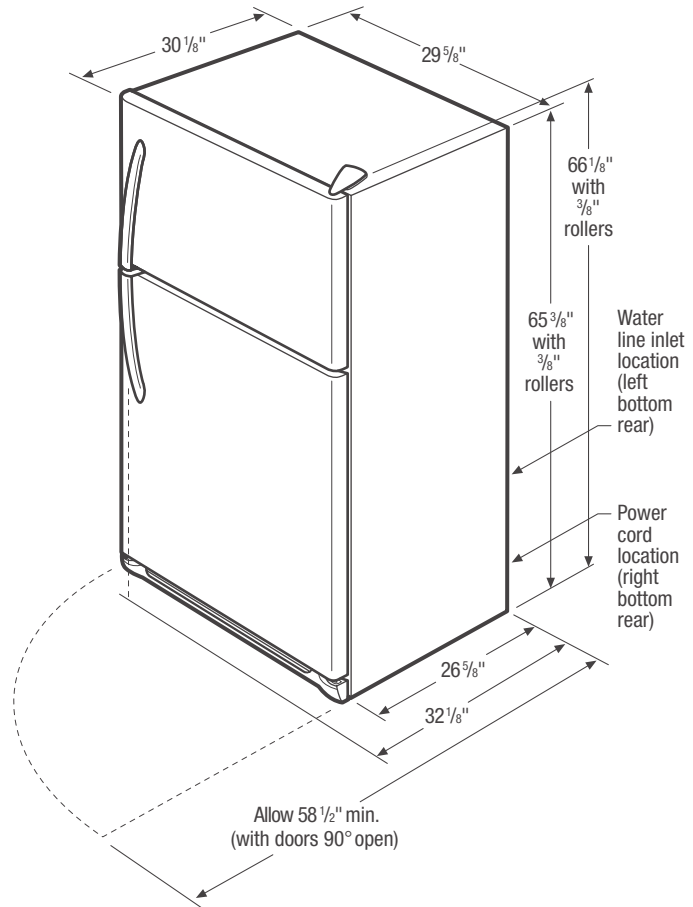

Top Mount Refrigerator Specifications

- Product Shipping Weight (approx.) - 205 Lbs.
- An electrical supply with grounded three-prong receptacle is required. The power supply circuit must be installed in accordance with current edition of National Electrical Code (NFPA 70) and local codes & ordinances.
- Voltage Rating - 120V/60 Hz
- Connected Load (kW Rating) @ 120 Volts = 0.72 kW
- Amps @ 120 Volts = 6.0 Amps
- Always consult local and national electric & plumbing codes.
- Floor should be level surface of hard material, capable of supporting fully loaded refrigerator.
- Minimum 3/8" clearance required for sides and top of refrigerator with 1" clearance at rear to allow for ease of installation, proper air circulation, and plumbing/electrical connections.
- When installing refrigerator adjacent to wall, cabinet or other appliance that extends beyond front edge of unit, 20" minimum clearance recommended to allow for optimum 140° door swing, providing complete crisper access and removal. (Absolute 3" minimum clearance will ONLY allow for 90° door swing which will provide limited crisper access with restricted removal.)

- To ensure optimum performance, do not install in areas where temperature drops below 55° F or rises above 110° F and avoid installing in direct sunlight or close proximity to range, dishwasher or other heat source.
- For proper ventilation, front grille MUST remain unobstructed.
- Recess electrical outlet when possible.
- Optional Ice Maker Kit (PN# IM116) available for installation in ice maker-ready models only.
- Water recess on rear wall recommended to prevent water line damage.
- Water Pressure - Cold water line must provide between 30 and 100 pounds per square inch (psi).
- Copper tubing with 1/4" O.D. recommended for water supply line with length equal to distance from rear of unit to household water supply line plus 7 additional feet. Optional Water Supply Installation Kits available.

Note: For planning purposes only. Refer to Product Installation Guide on the web at frigidaire.com for detailed instructions.

Optional Accessories

- Ice Maker Kit - (PN# IM116).

1. PART 1 GENERAL

1.1 SECTION INCLUDES

- A. Gypsum board.
- B. Taped and sanded joint treatment.

1.2 RELATED SECTIONS

- A. Section 06 10 00 - Framing and Sheathing
- B. Section 06 20 00 - Finish Carpentry
- C. Section 07 21 29 – Sprayed Insulation
- D. Section 07 21 30 - Batt & Blanket Insulation
- E. Section 07 90 00 - Joint Sealers
- F. Section 08 11 00 - Steel Doors and Frames
- G. Section 08 30 40 - Access Panels
- H. Section 08 41 00 - Aluminum Entrances and Storefronts and Windows
- I. Section 09 90 00 – Painting
- J. Section 13 06 20 – Walk-In Refrigerators and Freezers

1.3 REFERENCES

- A. ASTM C36 - Gypsum Wallboard.
- B. ASTM C442 - Gypsum Backing Board and Core Board.
- C. ASTM C475 - Joint Treatment Materials for Gypsum Wallboard Construction.
- D. ASTM C557 - Adhesive for Fastening Gypsum Wallboard to Wood Framing.
- E. ASTM C840 - Application and Finishing of Gypsum Board.
- F. ASTM C1002 - Steel Drill Screws for the Application of Gypsum Board.
- G. GA-201 - Gypsum Board for Walls and Ceilings.
- H. GA-216 - Recommended Specifications for the Application and Finishing of Gypsum Board.

1.4 QUALITY ASSURANCE

- A. Perform Work in accordance with ASTM C840. GA-201, GA- 216 and GA-600.
- B. Contractor is responsible for fully complying with the construction as indicated plus applicable code or manufacturer’s recommendations to achieve specified performance.
- C. Minor deviations in actual field performance may vary within standard industry tolerance, but in no case may be less than minimum Code STC requirements specified by IBC or HUD’s minimum property standards.
- D. Corridor and party walls: STC 50 minimum.
- E. Where a specific UL test assemble or hourly rating is given, Contractor is responsible for fully complying with necessary construction to achieve rating indicated.

1.5 QUALIFICATIONS

- A. Applicator: Company specializing in performing the work of this section with minimum 3 years documented experience.

2. PART 2 PRODUCTS

2.1 MANUFACTURERS - GYPSUM BOARD SYSTEM

- A. USG - Gypsum Board Systems
- B. National Gypsum
- C. Georgia Pacific
- D. Comparable product of other manufacturer

2.2 GYPSUM BOARD MATERIALS

- A. Fire Rated Gypsum Board: ASTM C36; fire resistive type, UL rated; 5/8 inch thick, maximum permissible length; ends square cut, tapered edges.
- B. Fire Rated Moisture Resistant Gypsum Board: ASTM C630; fire resistive type, UL rated; 5/8" thick, maximum permissible length; ends square cut; tapered edges.

2.3 ACCESSORIES

- A. Acoustical Sealant: Non-hardening, non-skinning, for use in conjunction with gypsum board.
- B. Acoustical Insulation: ASTM C665; preformed glass fiber, friction fit type, unfaced, 3 inch thick.
- C. Corner Beads: Metal.
- D. Sound Channel: RC - 1 Resilient Channel.
- E. Furring Channel: as required.
- F. Edge Trim: GA 201 and GA 216; Type L or J bead.
- G. Joint Materials: ASTM C475; GA 201 and GA 216; reinforcing tape, joint compound, adhesive, and water.
- H. Control joints: USG 093 or equal.
- I. Fasteners: ASTM C1002, Type S12 W and GA-216.

3. PART 3 EXECUTION**3.1 EXAMINATION**

- A. Verify that site conditions are ready to receive work and opening dimensions are as instructed by the manufacturer.

3.2 GYPSUM BOARD INSTALLATION

- A. Use moisture resistant gypsum board behind ceramic wall tile, at all toilet rooms, mechanical rooms, laundry rooms, and janitors closets. Use at all walls and chases containing plumbing. Do not use water resistant gypsum board for ceilings.
- B. Install acoustical insulation and sound channels at all corridor walls; all perimeter unit separation walls (interior); and where indicated.
- C. Install access panels furnished in Section 08 30 40 when part of a gypsum drywall finish system.
- D. Install gypsum board in accordance with GA-201, GA-216 and GA-600.
- E. Erect single layer fire rated gypsum board vertically, with edges and ends occurring over firm bearing.
- F. Utilize "floating interior angle" construction at ceiling/wall intersections.
 - 1. Provide installation utilizing slotted anchors and drywall chips at all truss/intermediate wall locations. Install according to gypsum board manufacturers' recommendations.
 - 2. Eliminate gypsum board fasteners at all truss/intermediate wall locations as follows:
 - a. Wall: eliminate fasteners from top 8" of wall
 - b. Ceiling: eliminate fasteners from 12" of ceiling adjacent wall.
- G. Use screws when fastening gypsum board to metal furring or framing.
- H. Use screws when fastening gypsum board to wood furring or framing.
- I. Place control joints consistent with lines of building spaces and at 30' - 0" on center maximum (coordinate location with architect.)
- J. Place corner beads at external corners and as indicated. Use longest practical length. Place edge trim where gypsum board abuts dissimilar materials.
- K. Sound attenuation batts: Install full width of studs to achieve STC ratings indicated on Drawings. Cut and pack tight without voids around equipment, outlets and boxes penetrating the wallboard.
- L. Maintain integrity of fire and sound ratings:
 - 1. Install sound and fire rated walls continuously behind soffits and furred ceilings, behind bathtubs and shower stalls, and at pipe chases.
 - 2. All spaces or joints formed between fire or sound rated wall, floor, ceiling or roof assemblies, or penetrations through such assemblies by pipe, conduit, ductwork any other items or voids provided for possible use of any item shall be caulked, grouted, filled or otherwise protected in a manner to maintain fire or sound ratings.
 - 3. Where any opening or penetration would be subject to moisture or weather it shall also be moisture proof and/or weatherproof as required.
 - 4. Joints of shaft wall systems which are concealed by, or within, other walls need not be sanded for painting but shall be taped and sealed.
- M. Tape, fill, and sand exposed joints, edges, and corners to produce smooth surface ready receive finishes. Provide light orange peel at walls and knock down at ceiling (as approved by Interior Designer)
- N. Feather coats onto adjoining surfaces so that camber is maximum 1/32 inch.
- O. Maximum Variation of Finished Gypsum Board Surface from True Flatness: 1/8 inch in 10 feet.

And at all unit bathroom fixtures such as showers and tubs that do not have a one-piece fiberglass enclosure. Still provide moisture resistant gypsum board above the enclosure on all sides.

A

3.4 DIRECT ATTACHMENT: SINGLE LAYER SYSTEM AT WOOD FRAME

- A. Apply gypsum panels to ceilings first.
- B. Position all ends over framing members in parallel application.
- C. Use maximum practical lengths to minimize end joints. Fit ends and edges closely, but not forced together.
- D. Stagger end joints in successive courses.
- E. Place end joints on opposite side of partitions on different studs.
- F. Secure panels in place, starting in center and working toward ends and edges.
 - 1. Space perimeter fasteners at least 3/8" from ends and edges.
- G. Method of attachment: Power-driven wood screws: attach gypsum panels with 1 1/4" type W screws spaced 16" oc maximum for walls and 12" oc for ceiling unless closer spacing is required by test assembly.

PART 1 GENERAL

1.1 SECTION INCLUDES

- A. Tile for floor applications.
- B. Tile for wall applications.

1.2 RELATED REQUIREMENTS

- A. Section 07 9200 - Joint Sealants: Sealing joints between tile work and adjacent construction and fixtures.

1.3 REFERENCE STANDARDS

- A. ANSI A108/A118/A136.1 - American National Standard Specifications for the Installation of Ceramic Tile (Compendium); 2013.1.
- B. ANSI A108.1a - American National Standard Specifications for Installation of Ceramic Tile in the Wet-Set Method, with Portland Cement Mortar; 2014.
- C. ANSI A108.1b - American National Standard Specifications for Installation of Ceramic Tile on a Cured Portland Cement Mortar Setting Bed with Dry-Set or Latex-Portland Cement Mortar; 1999 (Reaffirmed 2010).
- D. ANSI A108.1c - Specifications for Contractors Option: Installation of Ceramic Tile in the Wet-Set Method with Portland Cement Mortar or Installation of Ceramic Tile on a Cured Portland Cement Mortar Bed with Dry-Set or Latex-Portland Cement; 1999 (Reaffirmed 2010).
- E. ANSI A108.4 - American National Standard Specifications for Installation of Ceramic Tile with Organic Adhesives or Water Cleanable Tile-Setting Epoxy Adhesive; 2009 (Revised).
- F. ANSI A108.5 - American National Standard Specifications for Installation of Ceramic Tile with Dry-Set Portland Cement Mortar or Latex-Portland Cement Mortar; 1999 (Reaffirmed 2010).
- G. ANSI A108.6 - American National Standard Specifications for Installation of Ceramic Tile with Chemical Resistant, Water Cleanable Tile-Setting and -Grouting Epoxy; 1999 (Reaffirmed 2010).
- H. ANSI A108.8 - American National Standard Specifications for Installation of Ceramic Tile with Chemical Resistant Furan Resin Mortar and Grout; 1999 (Reaffirmed 2010).
- I. ANSI A108.9 - American National Standard Specifications for Installation of Ceramic Tile with Modified Epoxy Emulsion Mortar/Grout; 1999 (Reaffirmed 2010).
- J. ANSI A108.10 - American National Standard Specifications for Installation of Grout in Tilework; 1999 (Reaffirmed 2010).
- K. ANSI A108.11 - American National Standard for Interior Installation of Cementitious Backer Units; 2010 (Revised).
- L. ANSI A108.12 - American National Standard for Installation of Ceramic Tile with EGP (Exterior Glue Plywood) Latex-Portland Cement Mortar; 1999 (Reaffirmed 2010).
- M. ANSI A108.13 - American National Standard for Installation of Load Bearing, Bonded, Waterproof Membranes for Thin-Set Ceramic Tile and Dimension Stone; 2005 (Reaffirmed 2010).
- N. ANSI A118.3 - American National Standard Specifications for Chemical Resistant, Water Cleanable Tile-Setting and -Grouting Epoxy and Water Cleanable Tile-Setting Epoxy Adhesive; 2013 (Revised).
- O. ANSI A118.4 - American National Standard Specifications for Modified Dry-Set Cement Mortar; 2012 (Revised).
- P. ANSI A118.7 - American National Standard Specifications for High Performance Cement Grouts for Tile Installation; 2010 (Revised).
- Q. ANSI A118.10 - American National Standard Specifications for Load Bearing, Bonded, Waterproof Membranes For Thin-Set Ceramic Tile And Dimension Stone Installation; 2014.
- R. ANSI A118.15 - American National Standard Specifications for Improved Modified Dry-Set Cement Mortar; 2012.
- S. ANSI A137.1 - American National Standard Specifications for Ceramic Tile; 2013.1.
- T. TCNA (HB) - Handbook for Ceramic, Glass, and Stone Tile Installation; 2016.

1.4 ADMINISTRATIVE REQUIREMENTS

- A. Preinstallation Meeting: Convene a preinstallation meeting one week before starting work of this section; require attendance by all affected installers.

1.5 SUBMITTALS

- A. See Section 01 3000 - Administrative Requirements, for submittal procedures.
- B. Product Data: Provide manufacturers' data sheets on tile, mortar, grout, and accessories. Include instructions for using grouts and adhesives.
- C. Samples: Provide two tiles, actual size, illustrating pattern and color.
- D. Maintenance Data: Include recommended cleaning methods, cleaning materials, and stain removal methods.
- E. Maintenance Materials: Furnish the following for Owner's use in maintenance of project.
 - 1. See Section 01 6000 - Product Requirements, for additional provisions.
 - 2. Extra Tile: 10 square feet (1 square meters) of each size, color, and surface finish combination.

1.6 QUALITY ASSURANCE

- A. Maintain one copy of and ANSI A108/A118/A136.1 and TCNA (HB) on site.
- B. Manufacturer Qualifications: Company specializing in manufacturing the types of products specified in this section, with minimum five years of documented experience.
- C. Installer Qualifications: Company specializing in performing tile installation, with minimum of five years of documented experience.

1.7 DELIVERY, STORAGE, AND HANDLING

- A. Protect adhesives from freezing or overheating in accordance with manufacturer's instructions.

1.8 FIELD CONDITIONS

- A. Do not install solvent-based products in an unventilated environment.
- B. Maintain ambient and substrate temperature of 50 degrees F (10 degrees C) during installation of mortar materials.

1.9 WARRANTY

- A. Tile and Stone Installation System Warranty: Manufacturer's standard system warranty protecting against break down or deterioration of the tile setting system under normal usage, and ensuring the products are free from manufacturer defects. Manufacturer shall pay for replacement of its own products and replacement of finishing materials, including labor, for defective portions of the project. Warranty Period: 25 years.

PART 2 PRODUCTS

2.1 TILE

- A. Manufacturers: All products by the same manufacturer.
- B. Ceramic Tile: ANSI A137.1, standard grade.
 - 1. Continental Slate manufactured by Daltile or approved equivalent product.
 - a. <CER TILE-10>: 12 by 12 inches, Indian Red.
 - b. <CER TILE-20>: 12 by 12 inches, Indian Red.
 - c. <CER TILE-21>: 12 by 12 inches, Moroccan Brown.

2.2 SETTING MATERIALS

- A. Latex-Portland Cement Mortar Bond Coat: ANSI A118.4 or ANSI A118.15.
 - 1. Application(s): Use this type of bond coat where indicated below; basis of design product indicated.
 - a. Typical Floors:
 - 1) LATICRETE 254 Platinum.
 - 2) TEC Specialty Full Flex.
 - b. Typical Walls:
 - 1) LATICRETE 4-XLT.
 - 2) TEC Specialty Ultimate Large Tile.
 - 2. Products:
 - a. ARDEX Engineered Cements; ARDEX X 77 MICROTEC: www.ardexamericas.com.
 - b. LATICRETE International, Inc: www.laticrete.com.
 - c. ProSpec, an Oldcastle brand: www.prospec.com.
 - d. Mapei Corporation: www.mapei.com.
 - e. TEC Specialty: www.tecspecialty.com.
 - f. Substitutions: See Section 01 6000 - Product Requirements.
- B. Mortar Bed Materials: Pre-packaged mix of Portland cement, sand, latex additive, and water.

2.3 GROUTS

- A. Manufacturers:
 - 1. LATICRETE International, Inc: www.laticrete.com.
 - 2. Mapei Corporation: www.mapei.com.
 - 3. TEC Specialty: www.tecspecialty.com.
 - 4. Substitutions: See Section 01 6000 - Product Requirements.
- B. Polymer Modified Grout: ANSI A118.7 polymer modified cement grout.
 - 1. Applications: Use this type of grout for typical walls.
 - 2. Use sanded grout for joints 1/8 inch (3.2 mm) wide and larger; unsanded grout for joints less than 1/8 inch (3.2 mm) wide.
 - 3. Basis of Design:
 - a. LATICRETE International, Inc; LATICRETE PERMACOLOR Grout: www.laticrete.com.
 - b. TEC Specialty; PowerGrout.
 - c. Substitutions: See Section 01 6000 - Product Requirements.

C. Epoxy Grout: ANSI A118.3 chemical resistant and water-cleanable epoxy grout.

1. Applications: Floors.
2. Color(s): As selected by Architect from manufacturer's full line.
3. Basis of Design:
 - a. LATICRETE International, Inc; LATICRETE SpectraLOCK PRO Premium Grout.
 - b. TEC Specialty; Epoxy AccuColor EFX.
 - c. Substitutions: See Section 01 6000 - Product Requirements.

2.4 MAINTENANCE MATERIALS

A. Tile Sealant: Gunnable, silicone, siliconized acrylic, or urethane sealant; moisture and mildew resistant type.

1. Applications: Between tile and plumbing fixtures.
2. Color(s): As selected by Architect from manufacturer's full line.
3. Products:
 - a. LATICRETE International, Inc; LATICRETE LATASIL: www.laticrete.com.
 - b. TEC Specialty; Silicone Caulk.
 - c. Substitutions: See Section 01 6000 - Product Requirements.

2.5 ACCESSORY MATERIALS

A. Waterproofing Membrane: Specifically designed for bonding to cementitious substrate under thick mortar bed or thin-set tile; complying with ANSI A118.10.

1. Application: Provide at walls and ceilings in showers only. Provide at all floors.
2. Fluid or Trowel Applied Type:
 - a. Products:
 - 1) LATICRETE International, Inc; LATICRETE HYDRO BAN: www.laticrete.com.
 - 2) TEC Specialty; HydraFlex.
 - 3) Substitutions: See Section 01 6000 - Product Requirements.

PART 3 EXECUTION

3.1 EXAMINATION

- A. Verify that sub-floor surfaces are smooth and flat within the tolerances specified for that type of work and are ready to receive tile.
- B. Verify that wall surfaces are smooth and flat within the tolerances specified and are dust-free, and are ready to receive tile.
- C. Verify that sub-floor surfaces are dust-free and free of substances that could impair bonding of setting materials to sub-floor surfaces.
- D. Verify that concrete sub-floor surfaces are ready for tile installation by testing for moisture emission rate and alkalinity; obtain instructions if test results are not within limits recommended by tile manufacturer and setting materials manufacturer.
- E. Verify that required floor-mounted utilities are in correct location.

3.2 PREPARATION

- A. Protect surrounding work from damage.
- B. Vacuum clean surfaces and damp clean.
- C. Seal substrate surface cracks with filler. Level existing substrate surfaces to acceptable flatness tolerances.
- D. Prepare substrate surfaces for adhesive installation in accordance with adhesive manufacturer's instructions.

3.3 INSTALLATION - GENERAL

- A. Install tile and grout in accordance with applicable requirements of ANSI A108.1a thru A108.13, manufacturer's instructions, and TCNA (HB) recommendations.
- B. Lay tile to pattern indicated. Do not interrupt tile pattern through openings.
- C. Cut and fit tile to penetrations through tile, leaving sealant joint space. Form corners and bases neatly. Align floor joints.
- D. Place tile joints uniform in width, subject to variance in tolerance allowed in tile size. Make grout joints without voids, cracks, excess mortar or excess grout, or too little grout.
- E. Form internal angles square and external angles bullnosed.
- F. Sound tile after setting. Replace hollow sounding units.
- G. Keep control and expansion joints free of mortar, grout, and adhesive.
- H. Prior to grouting, allow installation to completely cure; minimum of 48 hours.
- I. Grout tile joints unless otherwise indicated. Use standard grout unless otherwise indicated.
- J. At changes in plane and tile-to-tile control joints, use tile sealant instead of grout, with either bond breaker tape or backer rod as appropriate to prevent three-sided bonding.

3.4 INSTALLATION - FLOORS - THIN-SET METHODS

A. Over interior concrete substrates, install in accordance with TCNA (HB) Method F115, with epoxy grout.

Provide waterproofing membrane under all tile.

1. Use uncoupling membrane under all tile unless other underlayment is indicated.

3.5 INSTALLATION - SHOWERS AND BATHTUB WALLS

A. At walls install in accordance with TCNA (HB) Method B412, over cementitious backer units with waterproofing membrane.

B. Grout with polymer modified grout.

3.6 INSTALLATION - WALL TILE

A. Over gypsum wallboard on wood or metal studs install in accordance with TCNA (HB) Method W243, thin-set with dry-set or latex-Portland cement bond coat, unless otherwise indicated.

3.7 CLEANING

A. Clean tile and grout surfaces.

3.8 PROTECTION

A. Do not permit traffic over finished floor surface for 4 days after installation.

PART 1 GENERAL

1.1 SECTION INCLUDES

- A. Suspended metal grid ceiling system.
- B. Acoustical units.

1.2 RELATED REQUIREMENTS

- A. Divisions 21 through 28 for mechanical and electrical components in acoustical ceilings.

1.3 REFERENCE STANDARDS

- A. ASTM C635/C635M - Standard Specification for the Manufacture, Performance, and Testing of Metal Suspension Systems for Acoustical Tile and Lay-in Panel Ceilings; 2013a.
- B. ASTM C636/C636M - Standard Practice for Installation of Metal Ceiling Suspension Systems for Acoustical Tile and Lay-In Panels.
- C. ASTM E580/E580M - Standard Practice for Installation of Ceiling Suspension Systems for Acoustical Tile and Lay-in Panels in Areas Subject to Earthquake Ground Motions; 2014.
- D. ASTM E1264 - Standard Classification for Acoustical Ceiling Products; 2014.

1.4 ADMINISTRATIVE REQUIREMENTS

- A. Sequence work to ensure acoustical ceilings are not installed until building is enclosed, sufficient heat is provided, dust generating activities have terminated, and overhead work is completed, tested, and approved.
- B. Do not install acoustical units until after interior wet work is dry.

1.5 SUBMITTALS

- A. See Section 01 3000 - Administrative Requirements, for submittal procedures.
- B. Product Data: Provide data on suspension system components and acoustical units.
- C. Samples: Submit two samples 4 x 6 inch (100 x 150 mm) in size illustrating material and finish of acoustical units.
- D. Maintenance Materials: Furnish the following for Owner's use in maintenance of project.
 - 1. See Section 01 6000 - Product Requirements, for additional provisions.
 - 2. Extra Acoustical Units: Quantity equal to 5 percent of total installed.

1.6 QUALITY ASSURANCE

- A. Suspension System Manufacturer Qualifications: Company specializing in manufacturing the products specified in this section with minimum three years documented experience.
- B. Acoustical Unit Manufacturer Qualifications: Company specializing in manufacturing the products specified in this section with minimum three years documented experience.

1.7 FIELD CONDITIONS

- A. Maintain uniform temperature of minimum 60 degrees F (16 degrees C), and maximum humidity of 40 percent prior to, during, and after acoustical unit installation.

PART 2 PRODUCTS

2.1 MANUFACTURERS

- A. Acoustic Tiles/Panels:
 - 1. Armstrong World Industries, Inc: www.armstrong.com.
 - 2. CertainTeed Corporation: www.certainteed.com.
 - 3. USG: www.usg.com.
 - 4. Substitutions: See Section 01 6000 - Product Requirements.
- B. Suspension Systems:
 - 1. Armstrong World Industries, Inc: www.armstrong.com.
 - 2. CertainTeed Corporation: www.certainteed.com.
 - 3. Rockfon, LLC: www.rockfon.com.
 - 4. USG: www.usg.com.
 - 5. Substitutions: See Section 01 6000 - Product Requirements.

2.2 ACOUSTICAL UNITS

- A. Acoustical Panels <ACT-1>: Painted mineral fiber, ASTM E1264 Type III, with the following characteristics:
1. Size: 24 by 24 inches (600 by 600 mm).
 2. Thickness: 3/4 inches (19 mm).
 3. NRC Range: 0.65 to 0.75, determined in accordance with ASTM E1264.
 4. Edge: Reveal edge.
 5. Surface Color: White.
 6. Suspension System: Exposed grid.
 7. Basis of Design Product: Mars ClimaPlus by USG.

2.3 SUSPENSION SYSTEM(S)

- A. Suspension Systems - General: Complying with ASTM C635/C635M; die cut and interlocking components, with stabilizer bars, clips, splices, perimeter moldings, and hold down clips as required.
- B. Exposed Steel Suspension System: Formed steel, commercial quality cold rolled; intermediate duty.
1. Profile: Tee; 15/16 inch (24 mm) wide face.
 2. Finish: White painted.

2.4 ACCESSORIES

- A. Support Channels and Hangers: Galvanized steel; size and type to suit application and ceiling system flatness requirement specified.
- B. Perimeter Moldings: Same material and finish as grid.
1. At Exposed Grid: Provide L-shaped molding for mounting at same elevation as face of grid.
- C. Touch-up Paint: Type and color to match acoustical and grid units.

PART 3 EXECUTION

3.1 EXAMINATION

- A. Verify existing conditions before starting work.
- B. Verify that layout of hangers will not interfere with other work.

3.2 INSTALLATION - SUSPENSION SYSTEM

- A. Install suspension system in accordance with ASTM C636/C636M, ASTM E580/E580M, and manufacturer's instructions and as supplemented in this section.
- B. Rigidly secure system, including integral mechanical and electrical components, for maximum deflection of 1:360.
- C. Locate system on room axis according to reflected plan.
- D. Install after major above-ceiling work is complete. Coordinate the location of hangers with other work.
- E. Hang suspension system independent of walls, columns, ducts, pipes and conduit. Where carrying members are spliced, avoid visible displacement of face plane of adjacent members.
- F. Where ducts or other equipment prevent the regular spacing of hangers, reinforce the nearest affected hangers and related carrying channels to span the extra distance.
- G. Do not support components on main runners or cross runners if weight causes total dead load to exceed deflection capability.
- H. Support fixture loads using supplementary hangers located within 6 inches (150 mm) of each corner, or support components independently.
- I. Do not eccentrically load system or induce rotation of runners.
- J. Perimeter Molding: Install at intersection of ceiling and vertical surfaces and at junctions with other interruptions.
1. Use longest practical lengths and miter corners.

3.3 INSTALLATION - ACOUSTICAL UNITS

- A. Install acoustical units in accordance with manufacturer's instructions.
- B. Fit acoustical units in place, free from damaged edges or other defects detrimental to appearance and function.
- C. Fit border trim neatly against abutting surfaces.
- D. Install units after above-ceiling work is complete.
- E. Install acoustical units level, in uniform plane, and free from twist, warp, and dents.
- F. Cutting Acoustical Units:
1. Make field cut edges of same profile as factory edges.
 2. Double cut and field paint exposed reveal edges.
- G. Where round obstructions occur, provide preformed closures to match perimeter molding.
- H. Install hold-down clips on panels within 20 ft (6 m) of an exterior door.

3.4 TOLERANCES

- A. Maximum Variation from Flat and Level Surface: 1/8 inch in 10 feet (3 mm in 3 m).
- B. Maximum Variation from Plumb of Grid Members Caused by Eccentric Loads: 2 degrees.

PART 1 GENERAL

1.1 RELATED SECTIONS

- A. Section 03 10 00 –Concrete
- B. Section 03 54 00 - Cementitious Underlayment
- C. Section 06 10 00 - Framing and Sheathing.
- D. Section 09 68 80 - Carpet - Glue Down to Slab

1.2 SECTION INCLUDES

- A. Vinyl flooring
- B. Resilient base
- C. Edge/reducer and divider strips
- D. Installation accessories
- E. Subfloor preparation

1.3 SUBMITTALS

- A. Submit on the following:
 - 1. Manufacturer’s color samples.

1.4 QUALITY ASSURANCE

- A. Provide each type of resilient flooring and accessories from a single manufacturer, including recommended primers, adhesives, sealants, and leveling compounds.

1.5 DELIVERY, STORAGE, AND HANDLING

- A. Deliver materials to project site in manufacturer’s original, unopened containers with labels indicating brand names, colors and patterns, and quality designations legible and intact.
- B. Store and protect materials in accordance with manufacturer’s recommendations.

1.6 PROJECT CONDITIONS

- A. Maintain minimum temperature of 65 degrees F and maximum temperature of 90 degrees F in spaces to receive resilient flooring for at least 48 hours prior to installation, during installation, and for not less than 48 hours after installation. Subsequently, maintain minimum temperature of 55 degrees F in areas where work is completed.
- B. Store resilient flooring materials in spaces where they will be installed for at least 48 hours before beginning installation.
- C. Install, resilient flooring and accessories after other finishing operations, including painting, have been completed.
- D. Do not install resilient flooring over concrete slabs until they have been cured and are sufficiently dry to achieve bond with adhesive as determined by resilient flooring manufacturer’s recommended bond and moisture test.
- E. Close areas to traffic and to other work until flooring is firmly set. Tile shall have 72 hours with no traffic.
- F. Where solvent based adhesives are used, provide safety spark proof fans when natural ventilation is not adequate.

2. PART 2 PRODUCTS All hard surface flooring must meet Science Certification System's FloorScore per EGCC 6.7a



2.1 MATERIALS

- A. Sheet Vinyl:
 - 1. Congoleum
 - a. Air Step Evolution
 - 2. Color by Interior Designer
- B. Resilient Base: FS SS-W-40, Type 2 vinyl; top set; coved
 - 1. Height: 4 inch; coved at resilient flooring, straight at carpet.
 - 2. Thickness: 1/8 inch
 - 3. Length: roll
 - 4. Manufacturer: Johnsonite, VPI, Roppe
- C. Vinyl Skirt: 10” high, straight edge, 1/8” thick.

2.2 ACCESSORIES

A. Adhesives: Waterproof, stabilized type as recommended by flooring manufacturer to suit material and substrate conditions. Comply with Rule 1168 of the South Coast Air Quality Management District. Sealants shall comply with Regulation 8, Rule 51 of the Bay Area Quality Management District.

1. Concrete Slab Primer: Non-staining type as recommended by flooring manufacturer.

B. Patching, Leveling, underlayments, and Joint Filler: Mastic Latex type equivalent to Armstrong latex underlayment S-180.

C. Edge Strip: Burke (800-669-7010) CTJ (Carpet to Tile); TR (Tile to Concrete); 4RS (Carpet to Concrete); CC (Carpet to Carpet).

D. Provide 1/4" hardwood underlayment over all plywood subflooring.

3. PART 3 EXECUTION

3.1 EXAMINATION

A. Examine subfloor surfaces to determine that they are dry, clean, and smooth.

B. Perform bond and moisture tests on concrete subfloors to determine if surfaces are sufficiently cured and dry as well as to ascertain presence of curing compound. Do not use curing compounds on concrete subfloors.

C. Do not allow resilient flooring work to proceed until subfloor surfaces are satisfactory. Indicate adverse conditions of any type by letter.

3.2 PREPARATION

A. Sand or grind subfloors to remove mortar, paint, other surface irregularities.

B. Fill all concrete sawcut joints with latex underlayment.

C. Where filing, patching, leveling is required of thickness exceeding 1/8 inch apply latex type underlayment in two or more applications. Apply compound in accordance with manufacturer's printed instructions.

D. Remove all debris, sand, other materials which would result in lack of adhesion or star cracking.

3.3 INSTALLATION

A. Install colors in pattern indicated in strict compliance with manufacturer's printed instructions.

Extend resilient flooring into toe spaces, door reveals, and into closets and similar opening.

B. Scribe, cut, and fit resilient flooring to permanent fixtures, built-in furniture and cabinets, pipes, outlets and permanent columns.

C. Tightly cement resilient flooring to sub base without open cracks, voids, raising and puckering at joints, telegraphing of adhesive spreader marks, or other surface imperfections. Hand roll resilient flooring at perimeter.

D. Lay tile from center marks established with principal walls, discounting minor offsets, so that the tile at opposite edges of room are of equal width. Adjust to avoid use of cut widths less than 1/2 tile at room perimeters. Lay tile square to room axis, unless otherwise shown.

E. Adhere tile flooring to substrates using full spread of adhesive applied in compliance with manufacturer's directions.

F. Apply wall base to walls, columns, pilasters, casework and other permanent fixtures in rooms or areas where base is required. Install base in lengths as long as practicable, with preformed corner units, or fabricated from base materials with mitered or coped inside corners. Tightly bond base to substrate throughout length of each piece, with continuous contact at horizontal and vertical surfaces. On masonry surfaces, or other similar irregular substrates, fill voids along top edge of resilient wall base with manufacturer's recommended adhesive filler material.

G. Apply butt type metal edge strips where shown on drawings or required, and before installation of resilient flooring. Secure units to substrate with countersunk stainless steel anchors, complying with manufacturer's recommendations.

H. Protect flooring against damage during construction period to comply with resilient flooring manufacturer's directions.

3.4 CLEANING

A. Perform following operations immediately upon completion of resilient flooring.

1. Sweep or vacuum floor thoroughly.

2. Do not wash floor until time period recommended by resilient flooring manufacturer has elapsed to allow resilient flooring to become well-sealed in adhesive.

3. Thoroughly clean floor.

4. Remove any excess adhesive or other surfaces blemishes, using appropriate cleaner recommended by resilient flooring manufacturers.

5. Coat floor with finish recommended by manufacturer. Verify selection with owner.

3.5 EXTRA MATERIALS

A. Deliver stock of extra materials to Owner. Furnish extra materials from same manufactured lot as materials installed and enclosed in protective packaging with appropriate identifying labels. Furnish one box for each type, color, pattern and size installed.

PART 1: GENERAL**1.1 SUMMARY Section Includes:**

- A. Slip, fade, stain, scratch, mold and mildew resistant composite wood decking and accessories approved for direct ground and water content.
- B. Related Requirements:
 - 1. LED Exterior Lighting: fixtures and wiring for deck lighting

1.2 REFERENCES

- A. Reference Standards:
 - 1. ASTM International (ASTM).
 - a. ASTM C518 Standard Test Method for Steady-State Thermal Transmission Properties by Means of the Heat Flow Meter Apparatus.
 - b. ASTM D143 Standard Test Methods for Small Clear Specimens of Timber.
 - c. ASTM D648 Standard Test Method for Deflection Temperature of Plastics Under Flexural Load in the Edgewise Position.
 - d. ASTM D1037 Standard Test Methods for Evaluating Properties of Wood-Base Fiber and Particle Panel Materials.
 - e. ASTM D1525 Standard Test Method for Vicat Softening Temperature of Plastics.
 - f. ASTM D1621 Standard Test Method for Compressive Properties of Rigid Cellular Plastics.
 - g. ASTM D1761 Standard Test Methods for Mechanical Fasteners in Wood.
 - h. ASTM D1929 Standard Test Method for Determining Ignition Temperature of Plastics.
 - i. ASTM D2394 Standard Test Methods for Simulated Service Testing of Wood and Wood-Base Finish Flooring.
 - j. ASTM D6109 Standard Test Methods for Flexural Properties of Unreinforced and Reinforced Plastic Lumber and Related Products.
 - k. ASTM D7032 Standard Specification for Establishing Performance Ratings for Wood-Plastic Composite and Plastic Lumber Deck Boards, Stair Treads, Guards, and Handrails.
 - l. ASTM E84 Standard Test Method for Surface Burning Characteristics of Building Materials.
 - 2. American Wood Council (AWC).
 - a. AWC NDS National Design Specification for Wood Construction.
 - 3. American Wood Protection Association (AWPA).
 - a. AWPA E1 Standard Method for Laboratory Evaluation to Determine Resistance to Subterranean Termite.
 - 4. International Codes Council (ICC).
 - a. ICC- ES AC174 Acceptance Criteria for Deck Board, Span Ratings and Guardrail Systems (Guards and Handrails).
 - 5. US Green Building Council (USGBC).
 - a. LEED V4 LEED (Leadership in Energy and Environmental Design): Green Building Rating System Reference Guide for Building Design and Construction.

1.3 SUBMITTALS

- A. Make submittals in accordance with [Section 01 33 00 - Submittal Procedures].
- B. Product Data: Manufacturer's standard specifications and descriptive literature, including:
 - 1. Manufacturer's product data sheets.
 - 2. Manufacturer's installation instructions.
 - 3. Material Safety Data Sheets (MSDS).
- C. Samples: One [12] inch long decking [and fascia] sample illustrating size, profile, color, and surface finish.
- D. Test Reports: Certified test reports showing compliance with specified performance characteristics and physical properties.
- E. Certificates: Product certificates signed by manufacturer certifying materials comply with specified performance characteristics and criteria, and physical requirements.
- F. Manufacturer's Field Reports: Submit manufacturer's field reports within 3 days of each manufacturer representative's site visit and inspection.
- G. Installer's Experience: Submit verification of evidence of work similar to the work of this section.
- H. Warranty: Fully executed, issued in Owner's name and registered with manufacturer, including Manufacturer's 3-year warranty, from date of substantial completion, covering defects in materials.

1.4 CLOSEOUT SUBMITTALS

- A. Maintenance Data: Manufacturer's instructions on care and cleaning of composite wood products.

1.5 QUALITY ASSURANCE

- A. Installer: Experienced in performing work similar to work of this Section

1.6 DELIVERY, STORAGE & HANDLING

- A. Deliver materials in accordance with manufacturer's written instructions.
 - 1. Deliver materials in manufacturer's original, unopened, undamaged containers with identification labels intact and product name and manufacturer clearly visible and sizes to suit project.
- B. Store materials protected from exposure to harmful environmental conditions, clean, dry, frost-free and at recommended temperature and humidity levels.
 - 1. Store composite wood level and flat, off ground or floor, with supports at each end and maximum 24 inches on center.
 - 2. Do not stack composite wood to heights greater than 12 feet high.
 - 3. Cover composite wood with waterproof covering, vented to prevent moisture buildup.

1.7 WARRANTY

- A. Project Warranty: Refer to Contract Conditions for project warranty provisions.
- B. Manufacturer's warranty: Submit, for owner's acceptance, manufacturer's standard warranty document executed by authorized company official.
 - 1. Manufacturer's warranty is in addition to and doesn't limit other rights owner may have under Contract Conditions.

PART 2 PRODUCTS

2.1 MANUFACTURER

- A. Advanced Environmental Recycling Technologies, Inc; 914 N Jefferson, Springdale, AR 72764; Phone: (866) 729-2378, (479) 756-7400; Fax: (479) 756-7410; Email: info@moistureshield.com; Website: www.moistureshield.com.

2.2 PERFORMANCE REQUIREMENTS

- A. Comply with ICC-ES Report ESR-2388.
- B. Composite Wood Decking: To ASTM D7032 and ASTM D1037.
- C. Thermal Transmission: To ASTM C518.
- D. Surface Burning Characteristics: To ASTM E84 Class C or Class III.
 - 1. Flame spread: 100.
 - 2. Smoke Developed: 350.
- E. Ignition Characteristics: To ASTM D1929
 - 1. Self Ignition: 741 degrees F.
 - 2. Flash ignition: 729 degrees F.
- F. Insect Resistance: To AWPA E1.
- G. Comply with Federal Manufactured Home Construction and Safety Standards.
- H. Flexural Properties: To ASTM D648 and ASTM D6109.
- I. Hardness: To ASTM D143.
- J. Abrasion Resistance: To ASTM D2394.
- K. Compressive Strength: To ASTM D1621, 962 psi.
- L. Heat Softening: Comply with ASTM D1525.

2.3 DESCRIPTION

- A. Slip, fade, stain, scratch, mold and mildew resistant composite wood decking with high recycled content and approved for direct ground and water contact. The MoistureShield Vantage Collection is an uncapped composite available in eight natural color options. The MoistureShield Pro Collection is a capped composite available in three rich, variegated color options.
 - 1. Acceptable material: Advanced Environmental Recycling Technologies, Inc., [MoistureShield Pro Collection] [MoistureShield Vantage Collection].

2.4 MATERIALS

- A. Decking: Reclaimed wood and polyethylene plastic with additives for coloring and inhibiting fungal and algal growth; free from toxic chemicals.
 - 1. Profiles:
 - a. Deck board: [1 × 6] [2 × 4] [2 × 6] [2 × 8] inches × [12] [16] [20] feet long [with grooves for concealed fastening].
 - b. Fascia Trim Board: 0.67 × 11.25 × 12 feet long.

MoistureShield Vantage available colors: Bridle, Cape Cod Gray, Earthtone, Rustic Cedar, Seasoned Mahogany, Desert Sand, Tigerwood, Walnut. MoistureShield Pro available colors: Brazilian Chestnut, Graystone, Ipe.

- 2. Colors: Verify color with Owner.
- 3. Recycled content: 95% total recycled content.

2.5 ACCESSORIES

- A. Mechanical Fasteners: To ASTM D1761.
 - 1. [Hot dip galvanized steel] [or] [stainless steel] [composite wood screws] [nails] of length in accordance with composite decking **manufacturer's written recommendations**.
- B. Guardrail System: To ICC-ES AC174.
 - 1. Acceptable material: MoistureShield [Composite Railing System] [Aluminum Railing System].
- C. Hidden Fasteners: [Coated steel] [Stainless Steel] deck clips capable of supporting deck boards above joists.
 - 1. Acceptable material: MoistureShield Deck Clips.
- D. Deck Lighting: LED [post cap lighting] [accent lighting] [rail lighting] [stair lighting] and accessories.
 - 1. Acceptable material: MoistureShield [Post Cap Light] [Bullet Lights] [Rail Strips] [Stair Light] [Post Light] and Lighting Accessories.

PART 3 EXECUTION**3.1 INSTALLER**

- A. Use only installers who have training and experience of work similar to the work of this Section.

3.2 EXAMINATION

- A. Verification of Conditions: Verify that conditions of substrate previously installed under other Sections or Contracts are acceptable for composite wood decking installation in accordance with manufacturer's **written recommendations**.
 - 1. Visually inspect substrate in presence of consultant.
 - 2. Inform consultant of unacceptable conditions immediately upon discovery.
 - 3. Proceed with installation only after unacceptable conditions have been remedied and after receipt of written approval to proceed from Consultant.
 - 4. Starting installation of composite wood decking implies substrate conditions are acceptable for Work of this Section.

3.3 INSTALLATION

- A. Install composite wood decking in accordance with manufacturer's written recommendations; For MoistureShield installation details, visit the manufacturer's website: www.moistureshield.com/installation.
- B. Deck Design: To AWC NDS; www.awc.org/codes/standards/publications
- C. Layout and install joists at [16 inch maximum on center when decking will be installed perpendicular to joists] [12 inch maximum on center when deck boards will be installed at an angle to joists].
 - 1. Do not exceed maximum spans in accordance with **manufacturer's written recommendations**.
 - 2. Ensure joists are level, plumb and square.

- D. ATTACH POSTS USING MECHANICAL FASTENERS TO DECKING FRAME AT 72 INCHES MAXIMUM ON CENTER.
 - 1. Do not notch posts.
- E. Install wiring for lighting in accordance with [Section 26 56 19 - LED Exterior Lighting].
- F. Install deck boards [in pattern indicated] [perpendicular] [diagonally] to joists [on hidden fastener deck clips] and secure with mechanical fasteners.
 - 1. Ensure each deck board has three joist supports minimum.
 - a. Use 2 minimum fasteners at each joist support.
 - b. Pre-drill fastener holes closer than 1 inch from deck board edges.
 - 2. Allow 1/4 inch side-to-side spacing between deck boards.
 - 3. Allow 1/8 inch minimum end-to-end spacing at butt joints between deck boards.
 - 4. Stagger butt joints on decks longer than 20 feet.
 - a. Stagger butt joints in adjacent rows one support minimum.
 - 5. Cut boards to fit around posts.
 - a. Allow 1/8 inch minimum space between deck boards and posts.
 - 6. Cut deck boards true and square to length after securing.
 - a. Rasp deck board edges to finish.

Specifier Note: Retain and edit the following paragraph only if there will be a deck railing system included in the project.

- 7. Install railing as indicated.
- 8. Install fascia trim boards as indicated.

Specifier Note: Retain and edit the following paragraph only if there will be deck lighting included in the project.

- 9. Install lighting in accordance with [Section 26 56 19 - LED Exterior Lighting] and **manufacturer's written instructions**.

3.4 CLEANING

- A. Perform daily progress cleaning.
 - 1. Leave work area clean at end of each day.
- B. Upon completion, remove surplus materials, rubbish, tools and equipment.
- C. Collect recyclable waste and dispose of at appropriate recycling facilities.
- D. Final Cleaning: Clean composite wood surfaces using conventional deck wash containing detergent or sodium hypochlorite.

3.5 PROTECTION

- A. Protect applied composite wood decking from damage during construction.
- B. Repair or replace adjacent materials damaged by installation of composite wood decking.

PART 1 GENERAL

1.1 SECTION INCLUDES

- A. Subfloor preparation
- B. Resilient base
- C. Edge/reducer and divider strips
- D. Installation accessories.

1.2 RELATED SECTIONS

- A. Section 03 10 00 – Concrete
- B. Section 03 54 00 - Cementitious Underlayment
- C. Section 06 10 00 - Framing and Sheathing
- D. Section 09 65 00/09 65 10 - Resilient Flooring

1.3 REFERENCES

- A. ANSI/ASTM D16 - Definitions of Terms Relating to Paint, Varnish, Laquer, and Related Products.
- B. FS DDD-C-1559 - Carpet, Loop, Low Pile Height, High Density, Woven or Tufted with Attached Cushioning.
- C. FSDDD-C-95 - Carpets and Rugs, Wool, Nylon, Acrylic, Modacrylic.
- D. FS DDD-C-0095 - Carpet and Rugs, Wool, Nylon, Acrylic, Modacrylic, Polyester, Polypropylene.
- E. FS DDD-C-1559 - Carpet, Loop, Low Pile Height, High Density, Woven or Tufted with Attached Cushioning.

1.4 SUBMITTALS

- A. Submit product data describing physical characteristics; sizes, patterns, colors available, and method of installation and samples.

1.5 OPERATION AND MAINTENANCE DATA

- A. Submit operation and maintenance data including maintenance procedures, recommended maintenance materials, and suggested schedule for cleaning and shampooing under provisions of Section 01 77 00.

1.6 REGULATORY REQUIREMENTS

- A. Conform to applicable code for carpet flammability requirements in accordance with ASTM E84.
- B. Conform to ANSI/ASTM E648.
- C. Carpet must meet **Carpet and Rug Institutes Green Label or Green Label Plus certification for carpet, pad and carpet adhesives.**

1.7 ENVIRONMENTAL REQUIREMENTS

- A. Store materials for three days prior to installation in area of installation to achieve temperature stability.
- B. Maintain minimum 70 degrees F ambient temperature three days prior to, during, and 24 hours after installation of materials.

PART 2 PRODUCTS

2.1 MATERIALS: As selected/approved by Interior Designer

- A. Carpet: See Interior Designer Finish Schedule
- B. Pad: See Interior Designer Finish Schedule
- C. Resilient Base: FS SS-W-40, Type 2 vinyl; top set; covered
 1. Height: 4 inch; covered at resilient flooring, straight at carpet.
 2. Thickness: 1/8 inch
 3. Length: roll
 4. Manufacturer: See Interior Designer Finish Schedule

2.2 ACCESSORIES

- A. Sub-Floor Filler: White premix latex; type recommended by carpet manufacturer.
- B. Primers and Adhesives: Waterproof: Low VOC: of types recommended by carpet manufacturer. Use low fume generating adhesive.
- C. Edge/Reducer Strips: 1 1/2" wide or as required beveled. To be approved by Interior Designer.

PART 3 EXECUTION

3.1 EXAMINATION

- A. Verify that substrate surfaces are smooth and flat and are ready to receive work.
- B. Verify concrete floors are dry to a maximum moisture content of 7 percent; and exhibit negative alkalinity, carbonization, or dusting.
- C. Beginning of installation means acceptance of existing substrate and site conditions.
- D. Verify that existing vinyl tile flooring is in good condition at areas to receive new carpet. Report any potential problem areas to architect. Prep floor as required and install carpet over existing vinyl tile flooring.
- E. Remove and dispose of existing carpet at areas to receive new carpet. Prep floor as required.

3.2 PREPARATION

- A. Remove all sub-floor ridges and bumps greater than 1/8" in 10 ft. Fill low spots, cracks, joints, holes, and other defects with sub-floor filler.
- B. Apply, trowel, and float filler to leave smooth, flat, hard surface.
- C. Prohibit traffic until filler is cured.
- D. Vacuum floor surface.

3.3 INSTALLATION

- A. Apply carpet and adhesive in accordance with manufacturers' instructions.
- B. Lay out rolls of carpet for approval.
- C. Verify carpet match before cutting to ensure minimal variation between dye lots.
- D. Double cut carpet, to allow intended seam and pattern match. Make cuts straight, true, and unfrayed. Edge seam carpet at public areas.
- E. Locate seams in area of least traffic.
- F. Fit seams straight, not crowded or peaked, free of gaps.
- G. Lay carpet on floors with run of pile in same direction as anticipated traffic.
- H. Do not change run of pile in any room where carpet is continuous through a wall opening into another room. Locate change of color or pattern between rooms under door centerline.
- I. Cut and fit carpet around interruptions.
- J. Fit carpet tight to intersection with vertical surfaces without gaps.
- K. Provide edge/reducer strips at junctions between carpet and concrete.

3.4 CLEANING

- A. Remove excess adhesive from floor, base, and wall surfaces without damage.
- B. Clean and vacuum carpet surfaces.

3.5 PROTECTION

- A. Prohibit traffic from carpet areas for 24 hours after installation.

3.6 MAINTENANCE STOCK

- A. At time of completion of installation, deliver to Owner extra materials equal to 1% of each type of material supplied. All material shall be new, with appropriate covering for storage and identified with appropriate labels.

PART 1 GENERAL

1.1 WORK INCLUDED

- A. Surface preparation.
- B. Surface finish schedule.

1.2 RELATED WORK

- A. Section 05 50 00 – Metal Fabrications
- B. Section 06 20 00 - Finish Carpentry
- C. Section 08 11 00 - Steel Doors and Frames
- D. Section 08 30 40 - Access Panels
- E. Section 09 25 00 - Gypsum Wallboard Systems

1.3 REFERENCES

- A. ANSI/ASTM D16 - Definitions of Terms Relating to Paint, Varnish, Laquer, and Related Products.

1.4 QUALITY ASSURANCE

- A. Product Manufacturer: Company specializing in manufacturing quality paint and finish products with three years experience.
- B. Applicator: Company specializing in commercial painting and finishing with three years experience.

1.5 REGULATORY REQUIREMENTS

- A. Conform to applicable code for flame/fuel/smoke rating requirements for finishes.
- B. MPI and green seal standards.

1.6 DELIVERY, STORAGE, AND HANDLING

- A. Deliver products to site under provisions of Section 01 60 00.
- B. Store and protect products under provisions of Section 01 60 00.
- C. Deliver products to site in sealed and labeled containers; inspect to verify acceptance.
- D. Container labeling to include manufacturer's name, type of paint, brand name, brand code, coverage, surface preparation, drying time, cleanup, color designation, and instructions for mixing and reducing.
- E. Store paint materials at minimum ambient temperature of 45 degrees F and a maximum of 90 degrees F, in well ventilated area, unless required otherwise by manufacturer's instructions.
- F. Take precautionary measures to prevent fire hazards and spontaneous combustion.

1.7 ENVIRONMENTAL REQUIREMENTS

- A. Provide continuous ventilation and heating facilities to maintain surface and ambient temperatures above 45 degrees F for 24 hours before, during, and 48 hours after application of finishes, unless required otherwise by manufacturer's instructions.
- B. Do not apply exterior coatings during rain or snow, or when relative humidity is above 50 percent, unless required otherwise by manufacturer's instructions.
- C. Minimum Application Temperatures for Latex Paints: 45 degrees F for interiors; 50 degrees F for exterior; unless required otherwise by manufacturer's instructions.
- D. Minimum Application Temperature for Varnish and Finishes: 65 degrees F for interior or exterior, unless required otherwise by manufacturer's instructions.
- E. Provide lighting level of 80 ft candles measured mid-height at substrate surface.

F. Comply with greenseal limits for VOC levels (in g/L)

- 1. Flat Topcoat: 50**
- 2. Non-flat Topcoat: 100**
- 3. Primer or Undercoat: 100**
- 4. Floor Paint: 100**
- 5. Anti-Corrosive Coating: 250**
- 6. Reflective Wall Coating: 50**
- 7. Reflective Roof Coating: 100**

PART 2 PRODUCTS

2.1 ACCEPTABLE MANUFACTURERS - PAINT, VARNISH, PRIMER, SEALERS

- A. Pratt and Lambert.
- B. Glidden Coatings and Resins, Division of SCM Corporation.
- C. Benjamin Moore and Co.
- D. PPG Industries, Pittsburgh Paints.
- E. Devoe and Reynolds Co.
- F. The Sherwin-Williams Company.
- G. Diamond-Vogel.

2.2 MATERIALS

- A. Pratt and Lambert Systems are called out in the schedules to establish quality and dry mil thickness of finished installation. Any manufacturer noted above may be used as long as quality and color requirements are met.
- B. Coatings: Ready mixed, except field catalyzed coatings. process pigments to a soft paste consistency, capable of being readily and uniformly dispersed to a homogeneous coating.
- C. Coatings: Good flow and brushing properties; capable of drying or curing free of streaks or sags.
- D. Accessory Materials: Linseed oil, shellac, turpentine, paint thinners and other materials not specifically indicated but required to achieve the finishes specified, of commercial quality.

2.3 FINISHES

- A. Refer to **Interior Designer Schedule for COLORS AND FINISHES**.

PART 3 EXECUTION

3.1 INSPECTION

- A. Verify that surfaces are ready to receive work as instructed by the product manufacturer.
- B. Examine surfaces scheduled to be finished prior to commencement of work. Report any condition that may potentially affect proper application.
- C. Measure moisture content of surfaces using an electronic moisture meter. Do not apply finishes unless moisture content of surfaces are below the following maximums:
 - 1. Plaster and Gypsum Wallboard: 12 percent
 - 2. Masonry, Concrete, and Concrete Unit Masonry: 12 percent
 - 3. Wood: 15 percent, measured in accordance with ASTM D2016.

3.2 COLOR

- A. Color will be selected by Interior Designer who will provide a final color schedule and reserves the right to select colors from full range of standard colors and intermixes including deep tones of any or all of the manufacturers specified.

3.3 PREPARATION

- A. Remove electrical plates, hardware, light fixture trim, and fittings prior to preparing surfaces or finishing.
- B. Correct minor defects and clean surfaces which affect work of this Section.
- C. Shellac and seal marks which may bleed through surface finishes.
- D. Impervious Surfaces: Remove mildew by scrubbing with solution of tri-sodium phosphate and bleach. Rinse with clean water and allow surface to dry.
- E. Gypsum Board Surfaces: Latex fill minor defects. Spot prime defects after repair.
- F. Galvanized Surfaces: Remove surface contamination and oils and wash with solvent. Apply coat of etching primer.
- G. Uncoated Steel and Iron Surfaces: Remove grease, scale, dirt, and rust. Where heavy coatings of scale are evident, remove by wire brushing or sandblasting; clean by washing with solvent. Apply a treatment of phosphoric acid solution, ensuring weld joints, bolts, and nuts are similarly cleaned. Spot prime paint after repairs.
- H. Shop Primed Steel Surfaces: Sand and scrape to remove loose primer and rust. Feather edges to make touch-up patches inconspicuous. Clean surfaces with solvent. Prime bare steel surfaces. Prime metal items including shop primed items.
- I. Interior Wood Items Scheduled to Receive Finish: Wipe off dust and grit prior to priming. Seal knots, pitch streaks, and sappy sections with sealer. fill nail holes and cracks after primer has dried; sand between coats.
- J. Wood Doors Scheduled for Painting: Seal top and bottom edges with primer.
- K. Prefinished products scheduled for painting: Follow manufacturer's instructions.

3.4 PROTECTION

- A. Protect elements surrounding the work of this Section from damage or disfiguration.
- B. Repair damage to other surfaces caused by work of this Section.
- C. Furnish drop cloths, shields, and protective methods to prevent spray or droppings from disfiguring other surfaces.
- D. Remove empty paint containers from site.

3.5 APPLICATION

- A. Apply products in accordance with manufacturer's instructions.
- B. Do not apply finishes to surfaces that are not dry.
- C. Apply each coat to uniform finish.
- D. Apply each coat of paint slightly darker than preceeding coat unless otherwise approved.
- E. Sand lightly between coats to achieve required finish.
- F. Allow applied coat to dry before next coat is applied.
- G. Where clear finishes are required, tint fillers to match wood. Work fillers into the grain before set. Wipe excess from surface.
- H. Prime back surfaces of interior woodwork scheduled to receive stain or varnish finish with gloss varnish reduced 25 percent with mineral spirits.
- I. Paint exposed mechanical, electrical panels and access panels occurring in finished areas. Color and texture to match adjacent surfaces.
- J. Field paint shop primed equipment as indicated on Drawings or specified herein. Items include:
 - 1. Electrical panel box covers in finished areas: field paint with alkyd enamel - 2 coats. Sand factory finish to ensure bond.

3.6 CLEANING

- A. As Work proceeds, promptly remove paint where spilled, splashed, or spattered.
- B. During progress of Work maintain premises free of unnecessary accumulation of tools, equipment, surplus materials, and debris.
- C. Collect cotton waste, cloths, and material which may constitute a fire hazard, place in closed metal containers and remove daily from site.

3.7 PAINTING SCHEDULE

- A. The following schedule is a general outline of the work included and is not intended to be a complete, detailed tabulation.
- B. The number of coats listed herein are field applied coats, and all coats will be required even though surfaces have been factory primed. A factory applied one-coat combination primer-finish shall be considered as a prime coat only.
- C. Where only finish coat is specified by name, painter shall select proper primer or undercoat for substratum according to manufacturer's recommendations.
- D. The painting contractor shall submit in writing prior to commencement, his proposed painting schedule specified herein. Identify all products to be used along with catalog numbers, both wet and dry mill thickness and number of coats to be applied.
- E. Glidden Paints are generally used herein as a standard of quality, and equivalent products of other approved manufacturers are acceptable unless noted otherwise.

3.8 SCHEDULE - EXTERIOR SURFACES

- A. Exterior ungalvanized ferrous metal, including hollow metal doors and frames, lintels, and miscellaneous metal work:
 - 1. 1 coat #4570 Glid Guard Metal Primer
 - 2. 2 coats #4500 Series Glid Guard Alkyd Enamel
- B. Exterior galvanized metal:
 - 1. 1 coat #5229 Glid Guard Metal Primer
 - 2. 2 coats #4500 Series Glid Guard Alkyd Enamel

3.9 SCHEDULE - INTERIOR SURFACES

- A. Interior ungalvanized ferrous metal, including (non-prefinished) hollow metal doors and frames, exposed structural steel, and miscellaneous metal work:
 - 1. 1 coat #4570 Glid Guard Metal Primer or Touch Up Shop Primer
 - 2. 2 coats #4600 Series Spred Lustre Enamel (Alkyd enamel at all doors and frames).
- B. Interior galvanized metal:
 - 1. 1 coat #5229 Glid Guard Metal Primer
 - 2. 2 coats #4600 Series Spred Lustre Enamel or to match adjacent wall finish or as directed by Interior Designer.
- C. Interior hardwood indicated to be stained, including all items not indicated to be prefinished:
 - 1. 1 coat #1600 Series Glid-Tone Wood Stain (verify color)
 - 2. 3 coats #82 Clear Spred Urethane Satin
- D. Gypsum wallboard and where indicated:
 - 1. 1 coat primer
 - 2. 2 coats #5800 Series Latex (eggshell finish, typical; semi gloss at bathrooms; flat at ceilings)

PART 1 GENERAL**1.1 SECTION INCLUDES**

- A. Markerboards and Tackboards.

1.2 RELATED REQUIREMENTS

- A. Section 06 1000 - Rough Carpentry: Blocking and supports.

1.3 REFERENCE STANDARDS

- A. ANSI A208.1 - American National Standard for Particleboard; 2009.
- B. ASTM A424/A424M - Standard Specification for Steel, Sheet, for Porcelain Enameling; 2009a (Reapproved 2016).
- C. ASTM E84 - Standard Test Method for Surface Burning Characteristics of Building Materials; 2015a.

1.4 SUBMITTALS

- A. See Section 01 3000 - Administrative Requirements, for submittal procedures.
- B. Product Data: Provide manufacturer's data on markerboard, tack board, trim, and accessories.
- C. Shop Drawings: Indicate wall elevations, dimensions, joint locations, special anchor details.
- D. Samples: Submit two samples 2 by 2 inch (50 by 50 mm) in size illustrating materials and finish, color and texture of tack board surfacing.
- E. Manufacturer's printed installation instructions.
- F. Maintenance Data: Include data on regular cleaning, stain removal.

1.5 QUALITY ASSURANCE

- A. Manufacturer Qualifications: Company specializing in manufacturing the products specified in this section with minimum three years documented experience.

1.6 WARRANTY

- A. See Section 01 7800 - Closeout Submittals, for additional warranty requirements.
- B. Provide five year warranty for markerboard to include warranty against discoloration due to cleaning, crazing or cracking, and staining.

PART 2 PRODUCTS**2.1 MANUFACTURERS**

- A. Visual Display Boards:
 - 1. Claridge Products and Equipment, Inc: www.claridgeproducts.com.
 - 2. MooreCo, Inc: www.moorecoinc.com.
 - 3. Polyvision Corporation (Nelson Adams): www.polyvision.com.
 - 4. Substitutions: See Section 01 6000 - Product Requirements.

2.0 VISUAL DISPLAY BOARDS

- A. Markerboards <MARK BRD-1>: Porcelain enamel on steel, laminated to core.
 - 1. Color: As selected from manufacturer's full range.
 - 2. Steel Face Sheet Thickness: 24 gage, 0.0239 inch (0.61 mm).
 - 3. Core: Particleboard, manufacturer's standard thickness, laminated to face sheet.
 - 4. Backing: Galvanized steel sheet, laminated to core.
 - 5. Size: As indicated on drawings.
 - 6. Frame: Extruded aluminum, with concealed fasteners.
 - 7. Frame Finish: Anodized, natural.
 - 8. Accessories: Provide chalk tray and map rail.
- B. Tackboards <TACK BRD-1>: Composition cork.
 - 1. Cork Thickness: 1/4 inch (6 mm).
 - 2. Color: As selected from manufacturer's full range.
 - 3. Backing: Hardboard, 1/4 inch (6 mm) thick, laminated to tack surface.
 - 4. Surface Burning Characteristics: Flame spread index of 25, maximum, and smoke developed index of 450, maximum, when tested in accordance with ASTM E84.
 - 5. Size: As indicated on drawings.
 - 6. Frame: Same type and finish as for markerboard.

C. Combination Units and Units Made of More Than One Panel: Factory-assembled markerboards and tack boards in a single frame, of materials specified above.

1. Join panels of different construction with H-shaped extruded aluminum molding finished to match frame.
2. Join panels of similar construction with butt joints, aligned and secured with steel spline concealed in edge of core.
3. Configuration: As indicated on drawings.
4. Units Too Large to Ship Assembled: Fully assembled in factory, then disassembled for shipping.

2.3 MATERIALS

- A. Porcelain Enamelled Steel Sheet: ASTM A424/A424M, Type I, Commercial Steel, with fired-on vitreous finish.
- B. Particleboard: ANSI A208.1; wood chips, set with waterproof resin binder, sanded faces.
- C. Steel Sheet Backing: Manufacturer's standard thickness, galvanized.
- D. Adhesives: Type used by manufacturer.

2.4 ACCESSORIES

- A. Map Rail: Extruded aluminum, manufacturer's standard profile, with cork insert and runners for accessories. 1 inch (25 mm) wide overall, full width of frame.
- B. Marker Tray: Aluminum, manufacturer's standard profile molded ends; concealed fasteners, same finish as frame.
- C. Mounting Brackets: Concealed.

PART 3 EXECUTION

3.1 EXAMINATION

- A. Verify that field measurements are as indicated.
- B. Verify that internal wall blocking is ready to receive work and positioning dimensions are as indicated on shop drawings.

3.2 INSTALLATION

- A. Install boards in accordance with manufacturer's instructions.
- B. Secure units level and plumb.
- C. Butt Joints: Install with tight hairline joints.

3.3 CLEANING

- A. Clean board surfaces in accordance with manufacturer's instructions.
- B. Remove temporary protective cover at Date of Substantial Completion.

PART 1 – GENERAL**1.1 RELATED WORK**

- A. Section 06 10 00 – Rough Carpentry
- B. Section 09 25 00 - Gypsum Board Systems

1.2 WORK INCLUDED

- A. Provide identifying devices throughout the building, as required.
- B. Supply G.C. or Owner with submittals detailing the numbering and naming of individual areas prior to placing order.
- C. Ensure that all signage meets all applicable handicap code requirements.

1.3 SUBMITTALS

- A. Submit product information in accordance with Section 01 33 00. Brochure of materials and installation details.

1.4 DELIVERY, STORAGE AND HANDLING

- A. Package, handle, deliver and store at the job site in a manner that will avoid damage. Damaged equipment will be rejected.

PART 2 – PRODUCTS**2.1 MANUFACTURER: As approved by Owner**

- A. Manufacturer: Inpro- Florence Collection – ADA Complaint
- B. Mounting: Per manufacturer instructions.
- C. Interior Signage: ADA Complaint for Character Proportion, Letters and Numerals, Brail Characters, Finish and Contrast, Signage without Pictograms. See Schedule to be provided by Interior Designer.
- D. Exterior Signage
 - 1. Parking Spaces for Handicapped Persons
 - a. The sign shall consist of a white rectangle with longer dimension vertical, having blue and white international symbol for the barrier-free environments. The sign shall be reflective.
 - b. The size of the sign shall be not less than 12" x 18".
 - c. The sign shall include the words 'reserved parking' and the words "vehicle I.D. Required" or other words with similar meaning.
 - d. Sign shall meet state and local code requirements. Supplier shall verify.

PART 3 – EXECUTION**3.1 INSTALLATION**

- A. Mounting location and height: Confirm with General Contractor or Owner prior to placement. All installations must conform with state and local code requirements.
 - 1. Permanent room signs must be mounted on wall adjacent to latch side of door.
 - 2. Where no latch side wall space, including at double doors, signs must be mounted on nearest adjacent wall.
 - 3. Mounting height must be 60" above floor to sign centerline.
 - 4. Mounting location must allow approach within 3" of sign without encountering protruding objects or standing within door swing.
- B. Accessible Parking Signs
 - 1. Signs shall be mounted so that the bottom of the sign is not less than 6 feet above the finished grade.
 - 2. Location of sign(s) as shown on the drawings.
- C. Protect after delivery to the site against all damage due to work of all trades. Install signs in location designated in schedule at heights, positions directed by the General Contractor or Owner or as detailed.
- D. Apply identification signs only to clean, dry surfaces that have been completely finished in accordance with drawings and specification.

| Suggested Specifications | Section 10 26 00
CS Acrovyn® 4000 Model SM-10N

Part 1 - General

1.01 Summary

- A. This section includes the following types of wall protection systems:
 - 1. Corner Guards
- B. Related sections: The following sections contain requirements related to this section:
 - 1. Handrails, Bumper Guards, Crash Rails, Accent Rails, Wall Covering, Wall Panels, Door Protection; refer to section 10 26 00 "Wall and Door Protection"
 - 2. Blocking in walls for fasteners; refer to section 09 22 00 "Supports for Plaster and Gypsum Board"

1.02 References

- A. National codes (IBC, UBC, SBCCI, BOCA and Life Safety)
- B. American Society for Testing and Materials (ASTM)
- C. Underwriters Laboratories (UL)
- D. California 01350 specification

1.03 Submittals

General: Submit the following in accordance with conditions of contract and Division 1 specification section 01 33 00 "Submittal Procedures":

- A. Product data and detailed specifications for each system component and installation accessory required, including installation methods for each type of substrate.
- B. Shop drawings showing locations, extent and installation details of corner guards. Show methods of attachment to adjoining construction.
- C. Samples for verification purposes: Submit the following samples, as proposed for this work, for verification of color, texture, pattern and end cap attachment and alignment:
 - 1. 12" (304.8mm) long sample of each model specified including end cap.
- D. Product test reports from a qualified independent testing laboratory showing compliance of each component with requirements indicated.
- E. Maintenance data for wall protection system components for inclusion in the operating and maintenance manuals specified in Division 1.

1.04 Quality Assurance

- A. Installer qualifications: Engage an installer who has no less than 3 years experience in installation of systems similar in complexity to those required for this project.
- B. Manufacturer's qualifications: Not less than 5 years experience in the production of specified products and a record of successful in-service performance.
- C. Code compliance: Assemblies should conform to all applicable codes including IBC, UBC, SBCCI, BOCA, Life Safety and CA 01350.
- D. Fire performance characteristics: Provide engineered PETG wall protection system components with UL label indicating that they are identical to those tested in accordance with ASTM E84 for Class A/1 characteristics listed below:
 - 1. Flame spread: 25 or less
 - 2. Smoke developed: 450 or less
- E. Impact strength: Provide wall protection components that have been tested in accordance with the applicable provisions of ASTM F476.
- F. Chemical and stain resistance: Provide wall protection system components with chemical and stain resistance in accordance with ASTM D543.
- G. Color match: Provide wall protection components that are color matched in accordance with the following:
 - 1. Delta Ecmc of no greater than 1.0 using CIELab color space. (Specifier note: Construction Specialties' colors are matched under cool white fluorescent lighting and computer controlled

INTERIOR PRODUCT SOLUTIONS

SPECIFICATION GUIDE

within manufacturing tolerances. Color may vary if alternate lighting sources are present.)

- H. Single source responsibility: Provide all components of the wall protection system manufactured by the same company to ensure compatibility of color, texture and physical properties.

1.05 Delivery, Storage and Handling

- A. Deliver materials to the project site in unopened original factory packaging clearly labeled to show manufacturer.
- B. Store materials in original, undamaged packaging in a cool, dry place out of direct sunlight and exposure to the elements. A minimum room temperature of 40°F (4°C) and a maximum of 100°F (38°C) should be maintained.
- C. Material must be stored flat.

1.06 Project Conditions

- A. Materials must be acclimated in an environment of 65°-75°F (18°-24°C) for at least 24 hours prior to beginning the installation.
- B. Installation areas must be enclosed and weatherproofed before installation commences.

Part 2 - Products

2.01 Manufacturers

- A. Interior surface protection products specified herein and included on the submittal drawings shall be manufactured by Construction Specialties, Inc.

2.02 Materials

- A. Engineered PETG: Extruded material should be high-impact Acrovyn 4000 with Shadowgrain texture, nominal .078" (1.98mm) thickness. Chemical and stain resistance should be per ASTM D543 standards as established by the manufacturer. Colors to be indicated in the finish schedule from one of manufacturer's available colors and patterns.
- B. Aluminum: Extruded aluminum retainers should be 6063-T6 alloy, nominal .062" (1.57mm) thickness. Minimum strength and durability properties as specified in ASTM B221.
- C. Fasteners: All fasteners to be non-corrosive and compatible with aluminum retainers. All necessary fasteners to be supplied by the manufacturer.

2.03 Corner Guards

- A. Engineered PETG Corner Guards to be CS Acrovyn: Surface mounted guards consisting of continuous retainer with snap-on Acrovyn 4000 cover. Color matched end caps to be provided for both partial and full height applications. Attachment hardware shall be appropriate for wall construction.
 - 1. **Model SM-10N 90° surface mounted corner guard with 3" (76.1mm) legs, 1" (25.4mm) radius bullnose cover and aluminum retainer. Select from one of Acrovyn solid colors or Chameleon™ simulated patterns.** (Specifier note: refer to the Acrovyn Cradle to Cradle Product Summary at www.acrovyn.com/c2c to determine which colors and patterns are *Cradle to Cradle Certified™* Gold or Silver. *Cradle to Cradle Certified™* is a certification mark licensed by the Cradle to Cradle Products Innovation Institute.)

2.04 Fabrication

- A. General: Fabricate wall protection systems to comply with requirements indicated for design, dimensions, detail, finish and member sizes.

Part 3 - Execution

3.01 Examination

- A. Verification of conditions: Examine areas and conditions under which work is to be performed and identify conditions detrimental to proper or timely completion.
 - 1. Do not proceed until unsatisfactory conditions have been corrected.

INTERIOR PRODUCT SOLUTIONS

SPECIFICATION GUIDE

3.02 Preparation

- A. Surface preparation: Prior to installation, clean substrate to remove dirt, debris and loose particles. Perform additional preparation procedures as required by manufacturer's instructions.
- B. Protection: Take all necessary steps to prevent damage to material during installation as required in manufacturer's installation instructions.

3.03 Installation

- A. Install the work of this section in strict accordance with the manufacturer's recommendations, using only approved mounting hardware and locating all components firmly into position, level and plumb.
- B. Temperature at the time of installation must be between 65°-75°F (18°-24°C) and be maintained for at least 48 hours after the installation.
- C. Adjust installed end caps as necessary to ensure tight seams.

3.04 Cleaning

- A. General: Immediately upon completion of installation, clean material in accordance with manufacturer's recommended cleaning method.
- B. Remove surplus materials, rubbish and debris resulting from installation as work progresses and upon completion of work.

3.05 Protection

- A. Protect installed materials to prevent damage by other trades. Use materials that may be easily removed without leaving residue or permanent stains.

PART 1 – GENERAL

Gas fire place. See Div. 090000

A

- A. Description of Work: Furnish all products, materials, accessories, and labor necessary to provide a complete installation of the factory built fireplaces within the specifications, drawings and other guidelines set forth for this project. All work shall also be performed within the scope of the manufacturer’s warranty.
- B. Related Sections:
 - 1. Division 15 Mechanical
 - 2. Division 16 Electrical
- C. Delivery, Storage & Handling: Delivery of all products shall be scheduled so as to allow for prompt installation immediately following delivery. All materials shall be fully protected from damage from other trades as well as damage from inclement weather and other unforeseen job site hazards.
- D. Quality Assurance: Any variations from the manufacturer’s installation instructions must be approved by the manufacturer’s technical support department in writing and submitted to the architect prior to submitting a bid. In addition, each bidder shall submit a copy of the most recent installation instructions and product literature for the required products. All accessories required shall be fully described and noted in the bid.

PART 2 – MATERIALS

2.1 MANUFACTURERS

- A. A. Manufactured Fireplaces: Electric, Model as selected by Interior Designer. **VERIFY TYPE, STYLE, COLOR WITH OWNER.** Provide remote for operation. Direct vent, size as shown on drawings, electronic ignition and remote control. Fixed glass panel. Verify front finish with G.C.
 - 1. Basis of Design: Heat & Glo; Mezzo36 Loft Forge Front, black trim; www.heatnglo.com.
 - 2. Lennox Hearth Products: www.ihp.us.com.
 - 3. Vermont Castings: www.vermontcastings.com.
 - 4. Substitutions: See Section 01 6000 - Product Requirements.

2.0 COMPONENTS

- A. Fire Box: Formed insulated steel cabinet, rectangular shaped interior, configured to include chimney outlet and cleanout, front air inlet and integral air outlet.
 - 1. Hearth Opening (nominal): As shown on drawings. Verify with G.C.

PART 3 EXECUTION

3.1 VERIFICATION OF CONDITIONS

- A. Verify that prepared openings are ready to receive work and opening dimensions are as indicated on drawings.
- B. Verify that proper power supply and fuel source are available.

3.2 INSTALLATION

- A. Install unit assembly in accordance with manufacturer's instructions.
- B. INSTALLATION:
 - 1. Surface conditions: examine the areas and conditions under which the work of this section will be performed. Correct conditions detrimental to the timely and proper completion of the work.
 - 2. Installation: install in strict accordance with the manufacturer’s recommendations.
 - 3. Instruct On-Site Manager/ Maintenance Superintendent in the correct operation of the accessories; provide maintenance suggestions per manufacturer.

PART 1 – GENERAL

1.1 RELATED WORK

- A. Section 06 10 00 – Rough Carpentry
- B. Section 09 25 00 - Gypsum Board Systems

1.2 WORK INCLUDED

- A. Work under this Section includes all fire extinguisher cabinets, and brackets as specified.

1.3 SUBMITTALS

- A. Submit product information in accordance with Section 01 33 00. Brochure of materials and installation details.

1.4 DELIVERY, STORAGE AND HANDLING

- A. Package, handle, deliver and store at the job site in a manner that will avoid damage. Damaged equipment will be rejected.

PART 2 – PRODUCTS

2.1 MANUFACTURER

- A. J.L. Industries
- B. Substitutions under provisions of section 01 60 00.

2.2 FIRE EXTINGUISHER CABINETS

- A. J.L. Industries: Ambassador 1017, white epoxy finish, V10.

2.3 FIRE EXTINGUISHER BRACKETS

- A. Manufacturers' standard surface-mounted wall brackets for installation indicated.

2.4 FIRE EXTINGUISHERS

- A. J.L. Industries: Manufacturer's standard 1A:10BC (Town homes)
- B. J.L. Industries: Manufacturer's standard 4A-60BC (Office for bracket mounting)

PART 3 – EXECUTION

3.1 INSTALLATION

- A. Install level and plumb, recessed into wall, true to line and in accord with approved installation details.
- B. Mounting height: 4'-0" to top of cabinet.
- C. Protect cabinet from damage after installation.

3.2 SCHEDULE

- A. Fire Extinguishers at each town home unit.
- B. Wall Bracket and Fire Extinguisher at office.

PART 1 – GENERAL

1.1 SECTION INCLUDES

A. Multiple mail boxes with hinged doors.

1.2 RELATED SECTIONS

A. Section 06 10 00 – Rough Carpentry

1.3 SUBMITTALS

A. Submit shop drawings under provisions of Section 01 33 00. Indicate locations, construction and anchorage details, dimensions, rough-in openings sizes, quantity and arrangement of box sizes, box numbers (verify numbering system with Interior Designer).

1.4 FIELD MEASUREMENTS

A. Verify that field measurements are as indicated on shop drawings.

PART 2 – PRODUCTS

2.1 MANUFACTURERS

MAILBOX-1 Recessed front load Florence 4C15D Black 51 mailboxes, 3 w/ADA reach



B. Substitutions under provisions of Section 01 60 00.

PART 3 – EXECUTION

3.1 EXAMINATION

A. Verify that prepared openings are ready to receive work.

3.2 INSTALLATION

A. Install in accordance with manufacturer's instructions and U.S. Postal Service regulations.

B. Install and secure boxes in position.

C. Install doors and adjust to operate smoothly.

PART 1 GENERAL

1.1 SECTION INCLUDES

- A. Closet shelving with integral hanging rods.
- B. Linen and storage shelving.

1.2 FIELD MEASUREMENTS

- A. Field measure all locations.

1.3 COORDINATION

- A. Coordinate work.

PART 2 PRODUCTS

2.1 MANUFACTURERS

- A. Rubbermaid – Model: Wardrobe Shelves
- B. Substitutions under provisions of section 01 60 00.

2.2 MATERIALS

- A. Where depth cannot be determined from the Drawings, provide the following depths.
 - 1. Closet shelves: 12"
 - 2. Linen and storage shelves: 16"
 - 3. All other shelves: 12" or as indicated

2.3 ACCESSORIES

- A. Mounting hardware as recommended by the manufacturer for the job conditions.
- B. Provide intermediate support for spans over 3"-6".

PART 3 EXECUTION

3.1 EXAMINATION

- A. Verify that openings are ready to receive the work.
- B. Ensure structural blocking and supports are correctly placed.

3.2 INSTALLATION

- A. Install shelving in accordance with manufacturer's instructions

108000 - BATH/TOILET ACCESSORIES

PART 1 – GENERAL

1.1 SECTION INCLUDES

A. Toilet and shower Accessories.

1.2 RELATED SECTIONS

- A. Section 06 10 00 – Rough Carpentry
- B. Section 06 20 00 – Finish Carpentry

1.3 QUALITY ASSURANCE

- A. Inserts and Anchorages: Furnish inserts and anchoring devices which must be set in concrete or built into masonry; coordinate delivery with other Work to avoid delay.
- B. Accessory Locations: Coordinate accessory locations with other Work to avoid interference and to assure proper operation and servicing of accessory units.

1.4 SUBMITTALS

- A. Product Data: Submit manufacturer's technical data and installation instructions for each toilet accessory.
- B. Setting Drawings: Provide setting drawings, templates, instructions, and directions for installation of anchorage devices in all Work.

PART 2 - PRODUCTS

2.1 ACCEPTABLE MANUFACTURERS

A. Toilet Accessories as indicated:

1. Bobrick Washroom Equipment, Inc. (specified products unless otherwise noted.)
2. Bradley Corporation
3. McKinney
4. American Specialties, Inc.
5. Koehler toilets or approved equal.
6. ADA Toilet Fixtures must be 17"-19" for compliance; avoid using Pfister faucets.
7. ADA Roll-in showers; verify with GC.

B. Resident Apartments (one each): By Interior Designer

1. Towel Bar
2. Towel Ring
3. Robe Hook
4. Toilet Paper Holder
5. Shower Rod
6. Shower Rod Ends
7. Medicine Cabinet 30" mirrored double door, surface mount (submit for approval)
8. Grab Bars:
 - a. Stools: 1 1/2" powder coat finish, ~~white~~, concealed mounting screws. Quantity and sized per drawings.
 - b. Showers: 1 1/2" stainless steel, knurled surface, concealed mounting screws. Quantity and sized per drawings.
 - c. All grab bars shall withstand a 250 lbs. load at midpoint without permanent deformation or pullout.

stainless steel 

C. Common area

1. Bath/Shower:
 - a. Towel Bar (2)
 - b. Toilet Paper Holder
 - c. Paper Towel Dispenser
 - d. Grab Bars:
 1. Stools: 1 1/2" powder coat finish, white, concealed mounting screws. Quantity and sized per drawings.
 2. Showers: 1 1/2" stainless steel, knurled surface, concealed mounting screws. Quantity and sized per drawings.

108000 - BATH/TOILET ACCESSORIES

- D. Kitchen: Paper Towel Dispenser
- E. Laundry: Paper Towel Dispenser

NOTE: All hardware accessory items such as towel bars, grab bars etc. shall be installed with screws designed to support devices. Any areas where backing is not encountered, contractor shall notify the General Contractor or Owner before proceeding.

Grab bars shall be installed capable of supporting 250# of weight (per code requirements).

1. Towel Bar
2. Towel Ring
3. Robe Hook
4. Toilet Paper Holder
5. Shower Rod
6. Shower Rod Ends
7. Medicine Cabinet 30" mirrored double door, surface mount
(submit for approval)
8. Grab Bars:
 - a. Stools: 1 1/2" powder coat finish , white, concealed mounting screws. Quantity and sized per drawings.
 - b. Showers: 1 1/2" stainless steel, knurled surface, concealed mounting screws. Quantity and sized per drawings.
 - c. All grab bars shall withstand a 250 lbs. load at midpoint without permanent deformation or pullout.

2.2 FABRICATION

- A. Fabricate toilet accessories of Type 302 or 304 stainless steel, satin finish, unless otherwise Specified or approved.
- B. Omit manufacturer's labels and imprinted names.
- C. Provide accessories produced by one manufacturer unless otherwise specified, or approved.
- D. Furnish fastening devices, including screws, bolts, anchors, and back plates. Match exposed portions of fastening devices with that of accessories.

PART 3 – EXECUTION

3.1 INSTALLATION

- A. Install toilet accessory units in accordance with manufacturer's instructions, using fasteners, which are appropriate to substrate and recommended by manufacturer of unit. Install units plumb and level, firmly anchored in locations and at heights indicated. Mounting heights as per local governing codes and the Uniform Federal Accessibility Standards (U.F.A.S.)
- B. Secure mirrors to walls in tamper-proof manner with special hangers, toggle bolts, or screws. Set units plumb, level, and square at locations indicated in accordance with manufacturer's instructions for type of substrate involved.

3.2 ADJUSTING AND CLEANING

- A. Adjust toilet accessories for proper operation and verify that mechanisms function smoothly. Replace damaged or defective items.
- B. Clean and polish all exposed surfaces after removing labels and protective coatings.

NOTE: ALL finishes & accessories to be verified with Interior Designer.

PART 1 – GENERAL

A. Extent of miscellaneous specialties as specified and indicated on Drawings, include, but are not limited to the following:

- 1. Security System
- 2. ~~Flagpole~~ No flagpole ▲ A
- 3. Outdoor gas grill and post
- 4. Furniture
- 5. Walk off mats; one at elevator lobby. Verify other locations with Interior Designer.
- 6. Other

PART 2 – PRODUCTS

A. **Electronic Security System:** Supplied By By electrician Refer to electrical specifications for installation. ▲ A

B. ▲ A

C. Gas grill and post: ▲ A

charcoal grill to match Phase II

PART 3 – EXECUTION

- A. Install miscellaneous specialties in accordance with manufacturer’s printed instructions.
- B. Install items plumb, level, and true. Provide anchors, bolts, and any other fastenings and materials necessary and required for a complete, professional finished job.

112000 - RESIDENTIAL EQUIPMENT

PART 1 – GENERAL

1.0 SUMMARY

- A. Provide all equipment as shown on drawings or specified. Submittals required for approval. All appliances are to meet efficiency energy standards; “Energy Star” compliant.
- B. Proposal to include delivery and installation and any incidental items required for use.
- C. Supplier shall closely coordinate all items within this section with the Project Manager/ G.C. covering all aspects of the kitchen equipment and related items. Submittals shall include all information necessary for mechanical connections.
- D. Supplier shall include a one-time trip to the facility after all equipment is installed to instruct staff on operation and maintenance procedures.

1.1 DESCRIPTION OF WORK

- A. Residential kitchen appliances and equipment, washers and dryers, and accessories. Coordination of equipment with Mechanical and Electrical Work.

1.2 RELATED SECTIONS

- A. Section 12 35 30 – Residential Casework
- B. Division 15 Mechanical
- C. Division 16 Electrical

1.3 SUBMITTALS

- A. Shop Drawings: Submit in accordance with Section 01 33 00.
- B. Samples: submit samples of factory finish to Owner for color selection and appearances acceptance.

1.4 PRODUCT DELIVERY, STORAGE AND HANDLING

- A. Provide suitable packing for all items to prevent damage from handling and from the elements during shipment and storage. Do not deliver until suitable storage space is available at the project site or installation can be made directly upon delivery.
- B. Deliver residential equipment to the project site, unload, distribute, uncrate, assemble as required, place in permanent position and connect up.

PART 2 - PRODUCTS

2.1 APARTMENT APPLIANCES: Verify with Owner/Interior Designer in consultation with Bottineau Phase II.

A.

See finish section with appliances from Phase II

B. INCLUDE IN BASE BID:

- 1. Nice appliances for Community Room
- 2. Four (4) extra appliances of each as well as AC units.

PART 3 – EXECUTION

3.1 INSTALLATION

- A. Install residential equipment appliances, washers and dryers in accordance with reviewed Shop Drawings and manufacturers printed instructions. Adjust operating parts of residential equipment for proper operation. Provide cords as required and anti-tip brackets.

3.2 ADJUSTING AND CLEANING

- A. Adjust equipment to ensure proper working order and conditions.
- B. Clean and remove all rubbish from the job site.
- C. Coordinate all deliveries with the General Contractor or Owner in conjunction with the progress of the construction.
- D. Installation shall include all incidental items required for use.
- E. Promptly notify General Contractor or Owner of any defects or damage.

PART 1 – GENERAL

1.1 SECTION INCLUDES

- A. Horizontal slat louver blinds.
- B. Operating hardware.

1.2 SYSTEM DESCRIPTION

- A. Horizontal slat louver blinds installed at window openings; manual control of raising and lowering by cord; open and closed point locking; blade angle adjustable by cord; control wand.

1.3 SUBMITTALS

- A. Submit under provisions of Section 01 33 00.
- B. Shop Drawings: Indicate method of attachment, clearances, and operation.

1.4 FIELD MEASUREMENTS

- A. Field measure all locations.

1.5 COORDINATION

- A. Coordinate work.

PART 2 – PRODUCTS

2.1 MANUFACTURERS

- A. Kirsch - Mini Blinds.
- B. Levolor/Lorentzen, Inc. - Rivera.
- C. Bali Blinds/Marathon Carey McFall – Classic Series.
- D. Substitutions under provisions of section 01 60 00.

2.2 MATERIALS

- A. Metal Slats: 1 inch wide; 0.011 thick spring tempered pre-finished aluminum horizontal slats, radiused slat corners, with manufacturing burrs removed.
- B. Slat Support: Woven polypropylene, ladder configuration.
- C. Head Rail: Pre-finished, formed aluminum heavy duty box; internally fitted with hardware, pulleys, and bearings for operation.
- D. Control Wand: Extruded aluminum round shape; length of window opening height less 3 inches.
- E. Head Support Bracket: Overhead head rail attachment.
- F. Accessory Hardware: Type recommended by blind manufacturer.

2.3 FINISHES

- A. Blind Slat and Head Rail Housing: color as selected.
- B. Control Wand: match blinds.

2.4 FABRICATION

- A. Fabricate blinds to fit openings with uniform edge clearance of 1/2 inch.

PART 3 – EXECUTION

3.1 EXAMINATION

- A. Verify that openings are ready to receive the work.
- B. Coordinate requirements with contractor to ensure structural blocking and supports are correctly placed.

3.2 INSTALLATION

- A. Install blinds in accordance with manufacturer's instructions.
- B. Secure in place with concealed fasteners.
- C. Place intermediate head supports at 12 inch o.c.

3.3 INSTALLATION TOLERANCES

- A. Maximum Variation of Gap at Window Opening Perimeter: 1/4 inch.
- B. Maximum Offset From Level: 1/8 inch.

3.4 ADJUSTING

- A. Adjust work under provisions of Section 01 77 00.
- B. Adjust blinds for smooth operation.

3.5 CLEANING

- A. Clean work under provisions of 01 77 00. Clean blind surfaces just prior to occupancy.

3.6 SCHEDULE

- A. All unit windows unless scheduled otherwise

122111 - VERTICAL BLINDS

PART 1 –GENERAL

1.1 SECTION INCLUDES

- A. Vertical blinds.
- B. Operating hardware.

1.2 SYSTEM DESCRIPTION

A. Vertical blinds directed by Interior Designer Schedule (unit window, community room, family room, office, etc); manual control sliding on track by control wand; blade angle adjustable by control wand. One way stack, manual operation, outside mount.

1.3 SUBMITTALS

- A. Submit under provisions of Section 01340.
- B. Shop Drawings: Indicate method of attachment, clearances, and operation.
- C. Samples for color selection.
- D. Installation Instructions
- E. Cleaning and Maintenance instructions

1.4 FIELD MEASUREMENTS

- A. Field measure all locations.

1.5 COORDINATION

- A. Coordinate work.

PART 2 - PRODUCTS

1.1 MANUFACTURERS

- A. Graber: Bali, Levolor, Hunter Douglas, or approved equal. Verify with Interior Designer.
- B. Substitutions under provisions of section 01 60 00

1.2 MATERIALS

- A. Headrail: Satin finish anodized aluminum
- B. Carriers: Molded nylon with detachable louver stem.
- C. Rotation control: Control Wand, (360°)
- D. Traversing and spacing of louvers: Nylon strap system.
- E. Vanes: 3 ½ " vinyl, crown style, free hanging. Color to be selected by Interior Designer from manufacturer's full range.
- F. Valence: round corner return with dust cover, match vane color.
- G. Installation brackets: As required for wall mounting.
- H. Control options: As selected by Interior Designer.

1.3 FINISHES

- A. Blind Slat and Head Rail Housing: color as selected by architect.
- B. Control Wand: match blinds.

PART 3 - EXECUTION

3.1 EXAMINATION

- A. Verify that openings are ready to receive the work.
- B. Coordinate requirements with contractor to ensure structural blocking and supports are correctly placed.

3.2 INSTALLATION

- A. Install blinds in accordance with manufacturer's instructions.
- B. Secure in place with concealed fasteners.
- C. Place intermediate head supports at 12 inch o.c.

3.3 INSTALLATION TOLERANCES

- A. Maximum Variation of Gap at Window Opening Perimeter: 1/4 inch.
- B. Maximum Offset From Level: 1/8 inch.

3.4 ADJUSTING

- A. Adjust work under provisions of Section 01700.
- B. Adjust blinds for smooth operation.

3.5 CLEANING

- A. Clean work under provisions of 01 77 00.
- B. Clean blind surfaces just prior to occupancy.

3.6 SCHEDULE

- A. To be provided by Interior Designer.

123500 - RESIDENTIAL CASEWORK

PART 1 – GENERAL

1.1 WORK INCLUDES

- A. Pre-finished wall and base kitchen cabinets, island cabinets, pantry cabinets.
- B. Bath vanities, linen cabinets.
- C. Kitchen plastic laminate countertops, and backsplashes.
- D. Hardware and accessories.

1.2 RELATED SECTIONS

- A. Section 11 31 00 – Residential Appliances
- B. Division 15 – Kitchen Sinks

1.3 SUBMITTALS

- A. Shop Drawings: Submit in accordance with Section 01 33 00.
- B. Samples: submit samples of finish for color and pattern selection and appearance acceptance.

1.4 APPLICABLE STANDARDS

- A. Comply with NKCA recommended minimum construction and performance standards of National Kitchen Cabinet Association.
- B. Kitchen cabinets shall have labels indicating manufacturer's name and symbol, and as complying with ANSIU 161.1 recommended minimum construction and performance standards for kitchen cabinets.

PART 2 - PRODUCTS

2.1 ACCEPTABLE MANUFACTURERS; Verify with Interior Designer.

- A. Kitchen Cabinets: Mid-Continent "Signature Series: oak princeton style"; raised panel style doors
- B. "Natural" Color
- C. Merillat Standard Cabinetry.
- D. Saco Cambridge Square series.
- E. Grandview, Lexington and Piedmont style.
- F. Distinctive Cabinet Design.
- G. Smart Cabinetry standard construction

2.2 MATERIALS

- A. Wall Cabinets: Nominal 12" deep, width and height as indicated.
- B. Base Cabinets: Nominal 24" deep and 36" high to top of counter, unless indicated otherwise, width as indicated.
- C. Shelves: Nominal full depth for wall and 21" manufacturer's standard depth for base cabinets, including corners.
- D. Provide drawer stops that will allow drawer to be removed but prevent accidental pull-outs.
- E. Drawers: Nominal full depth for base cabinets. All drawers shall have two metal ball bearing slides. **Dovetail joints construction.**
- F. Cabinet design: Square picture frame with oak plywood panel doors and beveled drawers, with self-closing hinges or catches. All exposed surfaces and face frames in prefinished oak.
- G. Extended stiles, fillers and blocking: Furnish as required to match cabinets. Toe spaces shall be finished to match cabinets. Field applied toe kicks.
- H. Finish exposed panels to match door panels.
- I. Sink Cabinets: Back panels and bottoms are required
- J. Finish, exposed wood: Manufacturer's standard prefinished transparent stain, plastic laminate or polyester.
- K. Hardware: Furnish and install manufacturer's standard hardware required for proper operation and fastening of moveable parts.
- L. Tops – post formed type with 1/16" plastic laminate (NEMA-LDI Class I) surface.
- M. Provide continuous tops for counter type cabinets without joints in straight top section 12' long or less. Provide edge at exposed sides of countertop, backsplash and end splash where shown.
- N. Top material shall be securely bonded to $\frac{3}{4}$ " plywood or other equivalent material.
- O. Provide for drop in type lavatories and sinks.
- P. Provide custom 24" deep tall cabinet for raised dishwasher with drawer below.

PART 3 – EXECUTION

3.1 CABINET FABRICATION

- A. Shop assemble cabinet units as large as can be delivered into the area of installation. Provide shop prepared attachment devices for the necessary field connections. Finish interior of cabinets with vinyl type sealer. Assemble face frames into rigid unit with no face nailing. Provide steel corner braces in each base cabinet.
- B. Protect finished surfaces with heavy-duty canvas or polyethylene sheets. Secure loose components, such as adjustable shelving and sliding and hinged elements from damage during delivery.

3.2 INSTALLATION

- A. Install prefinished cabinets as indicated, in accordance with reviewed Shop Drawings and manufacturer's printed instructions.
- B. Cabinets shall be protected against dampness during and after delivery. Store in well ventilated area of the building and where not exposed to extreme changes in temperature and /or humidity.
- C. Install units plumb, level, true and straight with no distortions. Shim as required using concealed shims. Secure to grounds, stripping and blocking with countersunk concealed fasteners and blind nailing as required. Scribe and fit for accurate fit to other finished work.
- D. Verify cutout size required for sinks furnished in Div. 15 Plumbing and coordinate as required.
- E. After completion of cabinet work, clean exposed exterior and interior surfaces, touch up finish as required, remove and refinish damages or soiled areas of finish, adjust and lubricate hardware for proper operation and repair damaged or defective Work as directed.

PART 1 GENERAL

1.1 SECTION INCLUDES

- A. Countertops for architectural cabinet work.
- B. Countertops for manufactured casework.

1.2 RELATED REQUIREMENTS

- A. Section 06 4100 - Architectural Wood Casework.
- B. Division 22 - Plumbing fixtures, sinks

1.3 REFERENCE STANDARDS

- A. ASTM E84 - Standard Test Method for Surface Burning Characteristics of Building Materials; 2015a.
- B. AWI/AWMAC/WI (AWS) - Architectural Woodwork Standards; 2014.
- C. AWMAC/WI (NAAWS) - North American Architectural Woodwork Standards, U.S. Version 3.0; 2016.
- D. ISFA 2-01 - Classification and Standards for Solid Surfacing Material; 2013.
- E. NEMA LD 3 - High-Pressure Decorative Laminates; 2005.
- F. PS 1 - Structural Plywood; 2009.

1.4 SUBMITTALS

- A. See Section 01 3000 - Administrative Requirements, for submittal procedures.
- B. Product Data: Manufacturer's data sheets on each product to be used, including:
 - 1. Preparation instructions and recommendations.
 - 2. Storage and handling requirements and recommendations.
 - 3. Specimen warranty.
- C. Shop Drawings: Complete details of materials and installation; combine with shop drawings of cabinets and casework specified in other sections.
- D. Selection Samples: Provide color chips representing manufacturer's full range of available colors and patterns.
- E. Installation Instructions: Manufacturer's installation instructions and recommendations.
- F. Maintenance Data: Manufacturer's instructions and recommendations for maintenance and repair of countertop surfaces.

1.5 DELIVERY, STORAGE, AND HANDLING

- A. Store products in manufacturer's unopened packaging until ready for installation.
- B. Store and dispose of solvent-based materials, and materials used with solvent-based materials, in accordance with requirements of local authorities having jurisdiction.

1.6 FIELD CONDITIONS

- A. Maintain environmental conditions (temperature, humidity, and ventilation) within limits recommended by manufacturer for optimum results. Do not install products under environmental conditions outside manufacturer's absolute limits.

PART 2 PRODUCTS

2.1 COUNTERTOPS

- A. Quality Standard: Custom Grade, in accordance with AWI/AWMAC/WI (AWS) or AWMAC/WI (NAAWS), unless noted otherwise.
- B. Plastic Laminate Countertops <PLAM CTOP-1>: High-pressure decorative laminate (HPDL) sheet bonded to substrate.
 - 1. Laminate Sheet: NEMA LD 3, Grade HGS, 0.048 inch (1.2 mm) nominal thickness.
 - a. Manufacturers:
 - 1) Formica Corporation: www.formica.com.
 - 2) Lamin-Art, Inc: www.laminart.com.
 - 3) Panolam Industries International, Inc.\Nevamar: www.nevamar.com.
 - 4) Panolam Industries International, Inc.\Pionite: www.pionitelaminates.com.
 - 5) Wilsonart: www.wilsonart.com.
 - 6) Substitutions: See Section 01 6000 - Product Requirements.
 - b. Surface Burning Characteristics: Flame spread index of 25, maximum; smoke developed index of 450, maximum; when tested in accordance with ASTM E84.
 - c. Finish: Matte or suede, gloss rating of 5 to 20.
 - d. Surface Color and Pattern: As selected by Architect from the manufacturer's Wilsonart Milano Amber line.
 - 2. Exposed Edge Treatment: Molded rubber edge sized to completely cover edge of panel.
 - a. Color: As selected by Architect from the manufacturer's full line.
 - 3. Back and End Splashes: Same material, same construction.
 - a. Provide where indicated on the Drawings.
 - 4. Fabricate in accordance with AWI/AWMAC/WI (AWS) or AWMAC/WI (NAAWS), Section 11 - Countertops, Custom Grade.

C. Solid Surfacing Countertops <SSURF CTOP-21>: Solid surfacing sheet or plastic resin casting over continuous substrate.

1. Flat Sheet Thickness: 1/2 inch (12 mm), minimum.
2. Solid Surfacing Sheet and Plastic Resin Castings: Complying with ISFA 2-01 and NEMA LD 3; acrylic or polyester resin, mineral filler, and pigments; homogenous, non-porous and capable of being worked and repaired using standard woodworking tools; no surface coating; color and pattern consistent throughout thickness.
 - a. Manufacturers:
 - 1) Avonite Surfaces: www.avonitesurfaces.com.
 - 2) Central Marble.
 - 3) Dupont: www.corian.com.
 - 4) Formica Corporation: www.formica.com.
 - 5) Wilsonart: www.wilsonart.com.
 - 6) Substitutions: See Section 01 6000 - Product Requirements.
 - b. Surface Burning Characteristics: Flame spread index of 25, maximum; smoke developed index of 450, maximum; when tested in accordance with ASTM E84.
 - c. Finish on Exposed Surfaces: Matte, gloss rating of 5 to 20.
 - d. Color and Pattern: Central Marble 965 White.
3. Other Components Thickness <SOLID SURF-20>: 1/2 inch (12 mm), minimum.
 - a. Color: Central Marble 965 White.
4. Back and End Splashes: Same sheet material, square top; minimum 4 inches (102 mm) high.

2.2 MATERIALS

A. Wood-Based Components:

1. Wood fabricated from old growth timber is not permitted.

B. Plywood for Supporting Substrate: PS 1 Exterior Grade, A-C veneer grade, minimum 5-ply; minimum 3/4 inch (19 mm) thick; join lengths using metal splines.

C. Countertop Support Members: Furniture grade, epoxy powder coated steel.

1. Basis of Design: Rakks Model EH-1818FM with cover bracket as manufactured by Rangine Corporation or approved equal.
- D. Adhesives: Chemical resistant waterproof adhesive as recommended by manufacturer of materials being joined.

2.3 FABRICATION

A. Fabricate tops and splashes in the largest sections practicable, with top surface of joints flush.

1. Join lengths of tops using best method recommended by manufacturer.
2. Fabricate to overhang fronts and ends of cabinets 1 inch (25 mm) except where top butts against cabinet or wall.
3. Prepare all cutouts accurately to size; replace tops having improperly dimensioned or unnecessary cutouts or fixture holes.

B. Provide back/end splash wherever counter edge abuts vertical surface unless otherwise indicated.

1. Secure to countertop with concealed fasteners and with contact surfaces set in waterproof glue.
2. Height: 4 inches (102 mm), unless otherwise indicated.
3. Detail top of backsplash to allow scribing of backsplash to wall.

C. Solid Surfacing: Fabricate tops up to 144 inches (3657 mm) long in one piece; join pieces with adhesive sealant in accordance with manufacturer's recommendations and instructions.

PART 3 EXECUTION

3.1 EXAMINATION

A. Do not begin installation until substrates have been properly prepared.

B. If substrate preparation is the responsibility of another installer, notify Architect of unsatisfactory preparation before proceeding.

C. Verify that wall surfaces have been finished and mechanical and electrical services and outlets are installed in proper locations.

3.2 PREPARATION

A. Clean surfaces thoroughly prior to installation.

B. Prepare surfaces using the methods recommended by the manufacturer for achieving the best result for the substrate under the project conditions.

3.3 INSTALLATION

A. Securely attach countertops to cabinets using concealed fasteners. Make flat surfaces level; shim where required.

B. Attach plastic laminate countertops using screws with minimum penetration into substrate board of 5/8 inch (16 mm).

C. Attach countertops using compatible adhesive as well as mechanical fasteners.

D. Seal joint between back/end splashes and vertical surfaces.

3.4 CLEANING: Clean countertops surfaces thoroughly.

3.5 PROTECTION

A. Protect installed products until completion of project.

B. Touch-up, repair or replace damaged products before Date of Substantial Completion.

PART 1 GENERAL**1.1 SECTION INCLUDES**

- A. Complete hydraulic elevator systems.
 - 1. Passenger type.
- B. Elevator Maintenance Contract.

1.2 RELATED REQUIREMENTS

- A. Section 05 5000 - Metal Fabrications: Includes elevator pit ladder, sill supports, and overhead hoist beams.
- B. Section 07 8400 - Firestopping: Fire rated sealant in hoistway.
- C. Section 09 2500 - Gypsum Board Assemblies: Gypsum shaft walls.
- D. Section 09 3000 - Tile: Floor finish in car. As selected by Interior Designer.
- E. Section 26 0534 - Conduit:
- F. Section 26 2717 - Equipment Wiring:

1.3 REFERENCE STANDARDS

- A. ADA Standards - Americans with Disabilities Act (ADA) Standards for Accessible Design; 2010.
- B. AISC 360 - Specification for Structural Steel Buildings; 2010.
- C. ASME A17.1 - Safety Code for Elevators and Escalators; 2013.
- D. ASME A17.2 - Guide for Inspection of Elevators, Escalators, and Moving Walks; 2014.
- E. ASTM A666 - Standard Specification for Annealed or Cold-Worked Austenitic Stainless Steel Sheet, Strip, Plate, and Flat Bar; 2015.
- F. AWS D1.1/D1.1M - Structural Welding Code - Steel; 2015 (Errata 2016).
- G. NEMA MG 1 - Motors and Generators; 2014.
- H. NFPA 70 - National Electrical Code; Most Recent Edition Adopted by Authority Having Jurisdiction, Including All Applicable Amendments and Supplements.
- I. NFPA 80 - Standard for Fire Doors and Other Opening Protectives; 2016.

1.4 ADMINISTRATIVE REQUIREMENTS

- A. Coordination:
 - 1. Coordinate work with other installers to provide conduits necessary for installation of wiring including but not limited to:
 - a. Elevator equipment devices remote from elevator machine room or hoistway.
 - b. Elevator pit for lighting and sump pump.
 - c. Fire alarm panel from controller cabinet.
- B. Preinstallation Meeting: Convene meeting at least one week prior to start of this work.
 - 1. Review schedule of installation, proper procedures and conditions, and coordination with related work.
- C. Construction Use of Elevator: Not permitted.

1.5 SUBMITTALS

- A. See Section 01 3000 - Administrative Requirements, for submittal procedures.
- B. Product Data: Submit data on following items:
 - 1. Signal and operating fixtures, operating panels, and indicators.
 - 2. Car design, dimensions, layout, and components.
 - 3. Car and hoistway door and frame details.
 - 4. Electrical characteristics and connection requirements.
- C. Shop Drawings: Submit drawings and details on following items:
 - 1. Elevator Equipment and Machines: Size and location of driving machines, power units, controllers, governors, and other components.
 - 2. Hoistway Components: Size and location of car guide rails, buffers, jack unit and other components.
 - 3. Rail bracket spacing; maximum loads imposed on guide rails requiring load transfer to building structural framing.
 - 4. Clearances and over-travel of car.
 - 5. Locations in hoistway of traveling cables and connections for car lighting and telephone.
 - 6. Location and sizes of hoistway and car doors and frames.
 - 7. Electrical characteristics and connection requirements.
 - 8. Indicate arrangement of elevator equipment and allow for clear passage of equipment through access openings.
- D. Samples: Submit samples illustrating car interior finishes, car and hoistway door and frame finishes, and handrail material and finish in the form of cut sheets or finish color selection brochures.
- E. Warranty Documentation: Submit manufacturer warranty and ensure that forms have been completed in Owner's name and registered with manufacturer.
- F. Initial Maintenance Contract.

G. Maintenance Contract: Submit proposal to Owner for standard five year continuing maintenance contract agreement in accordance with ASME A17.1 and requirements as indicated, starting on date initial maintenance contract is scheduled to expire.

1. Indicate in proposal the services, obligations, conditions, and terms for agreement period and for renewal options.

H. Operation and Maintenance Data:

1. Parts catalog with complete list of equipment replacement parts; identify each entry with equipment description and identifying code.
2. Operation and maintenance manual.
3. Schematic drawings of equipment and hydraulic piping, and wiring diagrams of installed electrical equipment with list of corresponding symbols to identify markings on machine room and hoistway apparatus.

1.6 QUALITY ASSURANCE

A. Manufacturer Qualifications: Company specializing in manufacturing the Products specified in this section with minimum ten years documented experience.

B. Installer Qualifications: Company specializing in performing the work of this section and approved by elevator equipment manufacturer.

C. Testing Agency Qualifications: Independent firm specializing in performing testing and inspections of the type specified in this section.

1.7 WARRANTY

A. See Section 01 7800 - Closeout Submittals, for additional warranty requirements.

B. Provide manufacturer's warranty for elevator operating equipment and devices for five years from Date of Substantial Completion.

PART 2 PRODUCTS

2.1 MANUFACTURERS

A. Basis of Design - Hydraulic Elevators: 330A by Schindler Elevator; www.schindler.com.

B. Other Acceptable Manufacturers - Hydraulic Elevators:

1. Otis Elevator Company: www.otis.com.
2. ThyssenKrupp Elevator: www.thyssenkruppelevator.com.

C. Substitutions: See Section 01 6000 - Product Requirements.

D. Products other than Basis of Design are subject to compliance with specified requirements and prior approval of Architect. By using products other than Basis of Design, the Contractor accepts responsibility for costs associated with any necessary modifications to related work, including any design fees.

E. Source Limitations: Provide elevator and associated equipment and components produced by the same manufacturer as the other elevator equipment used for this project and obtained from a single supplier.

2.2 HYDRAULIC ELEVATORS

A. Hydraulic Passenger Elevator:

1. Hydraulic Elevator Equipment:
 - a. Holeless hydraulic with cylinder mounted within hoistway.
2. Drive System:
 - a. Variable voltage variable frequency (VVVF) to modulate motor speed.
3. Operation Control Type:
 - a. Selective Collective Automatic Operation Control.
4. Interior Car Height: 96 inch (2438 mm).
5. Electrical Power: 208 volts; alternating current (AC); three phase; 60 Hz.
6. Rated Net Capacity: 3500 lbs (1590 kgs).
7. Rated Speed: 125 to 150 feet per minute (0.63 to 0.75 m per second).
8. Hoistway Size: As indicated on drawings.
9. Interior Car Platform Size: As indicated on drawings.
10. Elevator Pit Depth: 70 inch (1778 mm).
11. Overhead Clearance at Top Floor: 140 inch (3555 mm).
12. Travel Distance: As indicated on drawings.
13. Number of Stops: As indicated on drawings.
14. Number of Openings: 5 Front; 1 Rear.
15. Hydraulic Equipment Location: As indicated on drawings

2.3 COMPONENTS

A. Elevator Equipment:

1. Motors, Hydraulic Equipment, Controllers, Controls, Buttons, Wiring, Devices, and Indicators: Comply with NFPA 70. Refer to Section 26 2717
2. Guide Rails, Cables, Buffers, Attachment Brackets and Anchors: Design criteria for components includes safety factors in accordance with applicable requirements of Elevator Code, ASME A17.1.
3. Buffers:
 - a. Spring type for elevators with speed less than or equal to 200 feet per minute (1 m per second).
4. Lubrication Equipment:
 - a. Provide grease fittings for periodic lubrication of bearings.
 - b. Grease Cups: Automatic feed type.
 - c. Lubrication Points: Visible and easily accessible.

B. Electrical Equipment:

1. Motors: NEMA MG 1.
 2. Boxes, Conduit, Wiring, and Devices: As required by NFPA 70. Refer to Sections 26 0534 and 26 2717.
 3. Spare Conductors: Provide ten percent in extra conductors and two pairs of shielded audio cables in traveling cables.
4. Include wiring and connections to elevator devices remote from hoistway. Refer to Section 877.

2.4 PERFORMANCE REQUIREMENTS

- A. Regulatory Requirements: Comply with ASME A17.1.
- B. Accessibility Requirements: Comply with ADA Standards. Able to accommodate a 24" x 84" ambulance stretcher compliant with the Minnesota State Building Code.
- C. Perform structural steel design, fabrication, and installation in accordance with AISC 360.
- D. Perform welding of steel in accordance with AWS D1.1/D1.1M.
- E. Fabricate and install door and frame assemblies in accordance with NFPA 80 and in compliance with requirements of authorities having jurisdiction.
- F. Perform electrical work in accordance with NFPA 70.

2.5 OPERATION CONTROLS

A. Elevator Controls: Provide landing operating panels and landing indicator panels.

1. Landing Operating Panels: Metallic type, one for originating "Up" and one for originating "Down" calls, one button only at terminating landings; with illuminating indicators.
2. Landing Indicator Panels: Illuminating.
3. Comply with ADA Standards for elevator controls.

B. Interconnect elevator control system with building fire alarm and smoke alarm systems.

C. Door Operation Controls:

1. Program door control to open doors automatically when car arrives at floor landing.
2. Render "Door Close" button inoperative when car is standing at dispatch landing with doors open.
3. Door Safety Devices: Moveable, retractable safety edges, quiet in operation; equipped with photo-electric light rays.

D. Provide "Firefighter's Emergency Operation" in accordance with ASME A17.1.

1. Designated Landing: At first floor.

2.6 OPERATION CONTROL TYPE

A. Selective Collective Automatic Operation Control: Applies to car in single elevator shaft.

1. Refer to description provided in ASME A17.1.
2. Automatic operation by means of one button in the car for each landing served and by "UP" and "DOWN" buttons at the landings.
3. Stops are registered by momentary actuation of landing car buttons without consideration of the number of buttons actuated or the sequence buttons are actuated, but the stops are made in the order that landings are reached in each direction of travel.
4. All "UP" landing calls are made when car is traveling in the up direction.
5. All "DOWN" landing calls are made when car is traveling in the down direction.
6. Uppermost and lowermost calls are answered as soon as they are reached without consideration of the car travel direction.

2.7 EMERGENCY POWER

- A. Set-up elevator operation to run with elevator emergency power supply when the normal building power supply fails.
- B. Elevator Emergency Power Supply: Supplied by battery backup; provide elevator system components as required for emergency power characteristics.
- C. Emergency Lighting: Comply with ASME A17.1 elevator lighting requirements.
- D. Provide operational control circuitry for adapting the change from normal to emergency power.
- E. Upon transfer to emergency power, advance one elevator at a time to a pre-selected landing, stop car, open doors, disable operating circuits, and hold in standby condition.

2.8 MATERIALS

- A. Stainless Steel Sheet: ASTM A666, Type 304; No. 4 Brushed finish unless otherwise indicated.
- B. Ceramic Tile Flooring: As specified in Section 09 3000.

2.10 CAR AND HOISTWAY ENTRANCES

- A. Elevator, No. 1:
 - 1. Car and Hoistway Entrances, Main Elevator Lobby:
 - a. Framed Opening Finish and Material: Alkyd enamel on steel.
 - b. Car Door Material: Powder coat on steel, with rigid sandwich panel construction.
 - c. Hoistway Door Material: Powder coat on steel, with rigid sandwich panel construction.

2.10 CAR EQUIPMENT AND MATERIALS

- A. Elevator Car, No. 1:
 - 1. Car Operating Panel: Provide main and auxiliary; flush-mounted applied face plate, with illuminated call buttons corresponding to floors served with "Door Open/Door Close" buttons, "Door Open" button, "Door Close" button, and alarm button.
 - a. Panel Material: Integral with front return; one per car.
 - b. Car Floor Position Indicator: Above door with illuminating position indicators.
 - c. Locate alarm button where it is unlikely to be accidentally actuated; not more than 54 inch (1.372 m) above car finished floor.
 - 2. Front Return Panel: Stainless steel.
 - 3. Door Wall: Stainless steel.
 - 4. Side Walls: Plastic laminate on plywood.
 - 5. Rear Wall: Plastic laminate on plywood.
 - 6. Hand Rail: Stainless steel, at rear wall. 4 inches wide. Must be ADA compliant.
 - a. Stainless Steel Finish: No. 4 Brushed.
 - 7. Ceiling: Stainless Steel.

2.11 FINISHES

- A. Powder Coat on Steel: Clean and degrease metal surface; apply one coat of primer; two coats of powder coat.
- B. Finish Paint for Metal Surfaces: Alkyd enamel, semi-gloss, color as selected, complying with VOC limitations of authorities having jurisdiction.

PART 3 EXECUTION**3.1 EXAMINATION**

- A. Verify existing conditions before starting this work.
- B. Verify that hoistway and pit are ready for work of this section.
- C. Verify hoistway shaft and openings are of correct size and within tolerance.
- D. Verify location and size of machine foundation and position of machine foundation bolts.
- E. Verify that electrical power is available and of correct characteristics.

3.02 PREPARATION

- A. Arrange for temporary electrical power for installation work and testing of elevator components.
- B. Maintain elevator pit excavation free of water.
- C. Maintain in-ground elevator shaft excavation free of water.

3.3 INSTALLATION

- A. Coordinate this work with installation of hoistway wall construction.
- B. Install system components, and connect equipment to building utilities.
- C. Provide conduit, electrical boxes, wiring, and accessories. Refer to Sections 26 0534 and 26 2717.
- D. Install hydraulic piping between cylinder and pump unit.
- E. Mount machines, motors, and pumps on vibration and acoustic isolators.
 - 1. Place on structural supports and bearing plates.
 - 2. Securely fasten to building supports.
 - 3. Prevent lateral displacement.
- F. Install hoistway, elevator equipment, and components in accordance with approved shop drawings.
- G. Install guide rails to allow for thermal expansion and contraction movement of guide rails.
- H. Accurately machine and align guide rails, forming smooth joints with machined splice plates.
- I. Bolt brackets to inserts placed in concrete form work.
- J. Install hoistway door sills, frames, and headers in hoistway walls; grout sills in place, set hoistway floor entrances in alignment with car openings, and align plumb with hoistway.
- K. Fill hoistway door frames solid with grout in accordance with Section 04 2000.
- L. Structural Metal Surfaces: Clean surfaces of rust, oil or grease; wipe clean with solvent; prime two coats.
- M. Wood Surfaces not Exposed to Public View: Finish with one coat primer; one coat enamel.
- N. Adjust equipment for smooth and quiet operation.

3.4 TOLERANCES

- A. Guide Rail Alignment: Plumb and parallel to each other in accordance with ASME A17.1 and ASME A17.2.
- B. Car Movement on Aligned Guide Rails: Smooth movement, without any objectionable lateral or oscillating movement or vibration.

3.5 FIELD QUALITY CONTROL

- A. See Section 01 4000 - Quality Requirements, for additional requirements.
- B. Testing and inspection by regulatory agencies certified in accordance with ASME QEI-1 will be performed at their discretion.
 - 1. Schedule tests with agencies and notify Owner and Architect.
 - 2. Document regulatory agency tests and inspections in accordance with requirements.
 - 3. Perform tests required by regulatory agencies.
 - 4. Furnish test and approval certificates issued by authorities having jurisdiction.
- C. Perform testing and inspection in accordance with requirements.
 - 1. Perform tests as required by ASME A17.2.
 - 2. Provide at least two weeks written notice of date and time of tests and inspections.
 - 3. Supply instruments and execute specific tests.

3.6 ADJUSTING

- A. Adjust for smooth acceleration and deceleration of car to minimize passenger discomfort.
- B. Adjust with automatic floor leveling feature at each floor landing to reach 1/4 inch (6.4 mm) maximum from flush with sill.

3.7 CLEANING

- A. Remove protective coverings from finished surfaces.
- B. Clean surfaces and components in accordance with manufacturers written instructions.
- C. See Section 01 7419 - Construction Waste Management and Disposal, for additional requirements.

3.8 CLOSEOUT ACTIVITIES

- A. See Section 01 7800 - Closeout Submittals, for closeout submittals.
- B. Demonstrate proper operation of equipment to Owner's designated representative.
- C. Demonstration: Demonstrate operation of system to Owner's personnel.
 - 1. Use operation and maintenance data as reference during demonstration.
 - 2. Briefly describe function, operation, cleaning and maintenance of each component.
- D. Training: Train Owner's personnel on cleaning and operation and maintenance of system.
 - 1. Use operation and maintenance manual as training reference, supplemented with additional training materials as required.
 - 2. Provide minimum of two hours of training.

3.09 PROTECTION

- A. Do not permit construction traffic within car after cleaning.
- B. Protect installed products until Date of Substantial Completion.
- C. Touch-up, repair, or replace damaged products and materials prior to Date of Substantial Completion.

3.10 MAINTENANCE

- A. Refer to Section 01 7000 - Execution and Closeout Requirements, for additional requirements relating to initial maintenance service.
- B. Provide Initial Maintenance Contract of elevator system and components in accordance with ASME A17.1 and requirements as indicated for five years from Date of Substantial Completion .
- C. Perform maintenance contract services using competent and qualified personnel under the supervision and direct employ of the elevator manufacturer or original installer.
- D. Maintenance contract services shall not be assigned or transferred to any agent or other entity without prior written consent of Owner.
- E. Examine system components periodically.
- F. Include systematic examination, adjustment, and lubrication of elevator equipment.
- G. Maintain and repair or replace parts, whenever required, using parts produced by original equipment manufacturer.
- H. Perform work without removing cars from use during peak traffic periods.
- I. Provide emergency call back service during regular working hours throughout period of this maintenance contract.

PART 1 – GENERAL

1.1 DESCRIPTION

- A. This section specifies gravity trash chutes complete and ready for operation.
- B. Drawings and general provisions of Contract, including General, Supplemental and Special conditions and Division 01 Specification Sections, apply to this Section.

1.2 RELATED WORK

- A. Section 07 84 00, FIRESTOPPING.
- B. Section 07 60 00, FLASHING AND SHEET METAL.
- C. Section 21 10 00, WATER-BASED FIRE-SUPPRESSION SYSTEMS.
- D. Section 23 09 23, DIRECT-DIGITAL CONTROL SYSTEM FOR HVAC.
- E. Section 26 05 11, REQUIREMENTS FOR ELECTRICAL INSTALLATIONS.

1.3 SUBMITTALS

- A. Submit in accordance with Section 01 33 23, SHOP DRAWINGS, PRODUCT DATA, AND SAMPLES.
- B. Complete layout drawings of system, including detail drawings of load stations, roof vent, discharge openings, riser anchoring and electrical riser.
- C. Shop Drawings of Fabricated Equipment and Manufacturer's Literature and Data:
Submit as one package:
 - 1. Gravity Chute
 - 2. Roof Vents
 - 3. Flushing Head/Ring
 - 4. Gravity Chute Loading Stations
 - 5. Discharge Openings with Automatic Fire Damper
 - 6. Door Locks
- D. Manufacturer's certificate stating that the loading and discharge doors and frames meet the requirements of Underwriter's Laboratory, Inc. for the fire rating specified.

1.4 QUALITY ASSURANCE

- A. Criteria:
 - 1. Manufacturer regularly and presently manufactures the item submitted as one of their principal products.
 - 2. There is a permanent service organization maintained or trained by the manufacturer which will render satisfactory service to this installation within eight (8) hours of receipt of notification that service is requested.
 - 3. Installer, or supplier of a service, has technical qualifications, experience, and trained personnel and facilities to perform the specified work. A minimum of three (3) years of experience in the installation of gravity chutes.
 - 4. Manufacturer's system has been in satisfactory operation on two (2) installations similar to this system for at least two (2) years. Provide names of these facilities and contact information.

B. Product Criteria:

1. Multiple Units: When two (2) or more units of the same type or class of materials or equipment are required, these units are products of one manufacturer.
2. Assembled Units: Manufacturers of equipment assemblies, which use components made by others, assume complete responsibility for the final assembled product.
 - a. All components of an assembled unit need not be products of the same manufacturer, but component parts which are alike are the products of a single manufacturer.
 - b. Components are compatible with each other and with the total assembly for the intended service.
3. Nameplates: Nameplate bearing manufacturer's name or identifiable trademark securely affixed in a conspicuous place on equipment or name or trademark cast integrally with equipment, stamped, or otherwise permanently marked on each item of equipment.

C. Design Criteria:

1. The information shown on the contract drawings is intended to establish basic requirements of the system. Within these limitations, the Contractor is responsible for the final design of the gravity chute and to make whatever modifications of, and additions to the drawings, as may be required to fulfill the performance requirements.
2. Contractor is responsible for coordination of chute drawings and installation with all other building systems.
3. Space Conditions: Contractor shall pay special attention to existing structure provided in prior phases of construction.

D. Transport trash in plastic bags.

E. Employee Instructions: Provide a qualified representative possessing complete knowledge of system and equipment to train employees in operation and maintenance of system. Training period shall be as follows:

1. Four (4) hours instructing maintenance personnel on the operation and maintenance of system.
2. In addition to verbal instruction, furnish written instructions in triplicate relative to care, adjustment, and operating of all parts of equipment in independently bound folders. Written instructions shall include complete, correct, and legible wiring diagrams, complete and comprehensive sequence of operations, complete parts lists with descriptive literature and identifications, diagrammatic cuts of equipment and parts.

1.5 MAINTENANCE SERVICE

Furnish inspection and maintenance service on all chute equipment for a period of one (1) year after notification by Department of Veterans Affairs that system is turned over for beneficial use. This service shall consist of examination by competent trained and qualified mechanic; cleaning, oiling, greasing, adjustments and replacement of any parts required to place equipment in proper working order, (except for parts requiring replacement due to improper use, accidents or operator negligence). Maintenance is to be preformed monthly.

1.6 WARRANTY

- A. All labor and materials furnished in connection with the Gravity chutes shall be subject to terms of "Warranty of Construction" articles of FAR clause 52.246-21. Upon receipt of notice of any failure of any portion of materials or workmanship furnished, the failure shall be corrected at no additional cost.
- B. No device will be accepted that will not give perfect satisfaction without excessive maintenance and attention. If it becomes evident during the warranty period that the equipment is not functioning properly, or in accordance with specification requirements, or, if in the opinion of the Contracting Officer excessive maintenance and attention must be employed to keep equipment operating, the Contractor shall remove equipment and install a new device meeting all requirements as part of the work until satisfactory operation on installation is obtained. Period of warranty shall start a new from date of completion of new installation performed in accordance with foregoing requirements.

1.7 APPLICABLE PUBLICATIONS

- A. The publications listed below form a part of this specification to the extent referenced. The publications are referenced in the text by the basic designation only.
- B. Federal Specifications:
 - QQ-S-571E..... Solder, Electronic
 - WW-T-799F.....Tube, Copper, Seamless, Water (For Use with Solder-Flared or Compression-Type Fittings)
- C. National Fire Protection Association (NFPA):
 - 80-2010..... Fire Doors and Fire Windows
 - 82-2009..... Incinerators, Waste and Linen Handling Systems and Equipment
 - 90A-2012..... Installation of Air-Conditioning and Ventilating Systems
- D. American Society for Testing and Materials (ASTM):
 - A176-99(R2009)Stainless and Heat-Resisting Chromium Steel Plate, Sheet, and Strip
 - A463-10..... Steel Sheet, Cold-Rolled, Aluminum-Coated, Type 1 and Type 2
 - A653/A653M-11Steel Sheet, Zinc-Coated (Galvanized) by the Hot-Dip process, Commercial Quality
- E. Underwriter's Laboratories (UL): 555-2006 Safety Fire Dampers

PART 2 - PRODUCTS

2.1 GRAVITY CHUTE

- A. Risers:
 1. Galvanized steel conforming to ASTM A653 or aluminized steel conforming to ASTM A463.
 2. Chute parts extending above-roof shall conform to ASTM A176, Type 430 stainless steel.
 3. Provide slip type expansion joints in chute risers between floors, upper section telescoping into section below.
 4. Support chutes by frames and fasteners at each floor to prevent sound transmission to the floor slab as recommended by manufacturer. Weld and dress smooth connection joints between vertical shafts and horizontal intakes with no projections that may catch or tear the trash bags.
 5. Provide factory applied sound insulation with sprayed on sound deadening material.

149182 - TRASH CHUTE

6. Gravity chute shall meet the NFPA 82 requirements.
 7. Vent: Extend full chute diameter a minimum of 1292.2 mm (four feet) feet above roof level. Cap roof vent to prevent rain from entering chute and allow for the circulation of air within the chute riser.
- B. Provide Chute Fire Damper at Discharge Opening as indicated on drawings.
1. The base of the gravity chute shall terminate with sliding gate type discharge opening with a fire damper that carries the UL (1-1/2 hour 250 degrees F) "B" label, covering size, design and construction of gate, frame and closing mechanism. Dampers shall conform to UL 555."
 2. The base of the chute (Discharge Opening) shall terminate with a single 45 degree radius sweep section.
 - a. The 45 degree sweep shall be reinforced at the bottom by steel. Support bottom of sweep with flange for bolting to floor.
 - b. Door for the Discharge Opening shall be 609.6 mm (24 inches) wide by 762 mm (30 inches) high, top hinged with hold open device and fusible link.
- C. Provide Gravity Chute disinfecting and sanitizing device as indicated on drawings:
1. Equip chute at top with copper flushing rings containing 1.5 mm (1/16 inch) diameter spray holes, 65 mm (2 1/2 inches) on centers with extra holes which shall completely drain ring when water is shut off. In lieu of flushing rings, chute may be equipped with spray heads designed to flush inside of chute.
 2. Contractor shall provide all necessary fittings to water supply piping.
 3. Equip bottom of chute with hinged access for cleaning and water removal.

2.2 GRAVITY CHUTE LOADING STATIONS

- A. Fabricate loading station of 16 gauge stainless steel. Station shall consist of the intake door mounted in a single face plate. The intake door shall have pivot type hinges, and be located as indicated on drawings.
- B. Intake doors shall carry the UL (1-1/2 hour 250 degrees F) "B" label, covering size, design and construction of the door, frame, latching, and closing mechanism. Fabricate door of stainless steel and provide self-closing and self-latching devices. Door size shall be a minimum of 318 mm (15-inch) wide by 457.2 mm (18-inch) high, bottom hinged with cylinder lock. Install door frame flush with finished wall.
1. Each intake door shall have an indicator showing when the door is locked.
 2. Clearly letter on the intake door in letters approximately one-inch high, the word "TRASH". Raise or incise letters in door face in permanent manner. Raised lettering shall be metal or plastic with metal attachment.
 3. Provide cylinder locks, keyed the same, for all load stations. Furnish 15 keys for each chute. Stamp the letters "TRASH CHUTE KEY" on each key tag to identify location of use.
- C. Provide intake and shroud doors with electric interlocking mechanism to permit only one door in a riser to be opened at a time.
- D. The shroud shall be no less than 45⁰ angle, but shall be 60⁰ when possible.

- E. Access Door to be 318 mm (15 inches) by 318 mm (15 inches), with an UL (1-1/2 hour 250 degree F) "B" label, located where indicated on drawings. (Locate access door to service the flushing ring.)
 - 1. Provide hand-operated latch release device.
 - 2. Provide anchors for door frame of type to suit material of wall in which they are installed.

PART 3 - EXECUTION

3.1 INSTALLATION

- A. Gravity Chute Loading Stations:
 - 1. Set station flush with adjacent surface.
 - 2. Attach face plate to supports with stainless steel screws.
- B. Hangers:
 - 1. Provide supports at each floor line and at the roof line.
- C. Automatic Fire Dampers: Shall conform to UL 555 and NFPA 82.
- D. Protection: Protect all finish parts of equipment, such as shafts and bearing where accessible, from rust prior to operation by means of protective grease coating and wrapping. Close pipe openings with caps or plugs during installation. Cover and protect equipment against dirt, water, and chemical or mechanical injury. Clean all exposed surfaces and components at completion of all work.

3.2 TESTS:

- A. Demonstrate entire system will with fully loaded waste bags and that it operates as specified. Demonstrate operation of fire damper at discharge opening.
- B. Resident Engineer shall witness the system testing and final inspection.

MECHANICAL SYSTEMS SUMMARY BASIS OF DESIGN
FOR
BOTTINEAU RIDGE III APARTMENTS
MAPLE GROVE, MN

MECHANICAL REQUIREMENTS BASIS OF DESIGN & SYSTEMS NARRATIVE

15010 GENERAL PROVISIONS

1. This document was prepared to give a general scope of mechanical work to obtain mechanical pricing. Mechanical pricing shall include all plumbing, HVAC, fixtures, equipment, controls, terminal devices, etc. necessary for complete systems.
2. This document is not to be construed to be a complete design or used for city submittals. The specifications covering the Mechanical System are performance in nature and are not Certified Engineering complete in every detail. These specifications are intended to assist the Contractor in determining the scope of the work, systems to be installed, and to indicate the approximate locations with respect to other systems. It shall be the Contractor's responsibility to design and provide engineered drawings for a plumbing and mechanical systems conforming to the building construction, code requirements, Federal, State and local ordinances, Health department, requirements of agencies working in a regulatory or advisory capacity, and any other authorities having jurisdiction (all trades included). The plumbing and mechanical system shall be to the complete satisfaction of the owner.
3. The mechanical work shall be installed in conformance with all general and special conditions listed elsewhere in the specification. All work shall be coordinated with the work of other trades and specification divisions to provide a complete and working system installed in conjunction with architectural layouts and details. All charges from utility companies shall be paid for as part of the mechanical contract.
4. Scope: The project consists of one 50 unit four story apartment building over single story heated garage.
5. The apartment building shall be hot water heat with baseboard radiation, through wall air conditioner, ducted range hood, bathroom exhaust and make-up air. Heat and ventilation for public space shall be through sealed combustion furnaces with remote air cooled condensing units. Provide outside air/make-up air to each space as required by code. Garage shall be tempered to 55 degrees and provided with CO/NO2 detectors, exhaust fan, intake louvers and hot water unit heaters.

Per Bottineau Ridge III Green Communities Criteria 5.1a., The Project will retain a HERS rater to certify the dwelling units and have the mechanical contractor provide the Energy Star checklist. Per AH Green Communities Criteria 5.4, certified EnergyStar equipment, appliances and fixtures will be used in all units.

6. This document was prepared to give a general scope of mechanical work to obtain mechanical pricing. Mechanical pricing shall include all piping, ductwork, fans, dampers, controls, boilers, tanks, pumps, fixtures, etc. necessary for complete systems.
7. Project to be constructed on a design build basis for which the design build mechanical contractor shall assume full responsibility for the resulting mechanical systems and their

MECHANICAL REQUIREMENTS BASIS OF DESIGN & SYSTEMS NARRATIVE

implementation. The requirements of this summary are minimum requirements with the design build mechanical contractor fully responsible for the resulting installation.

8. The design build mechanical contractor shall provide complete detailed mechanical drawings and equipment specifications for the complete installation certified by and completed under the supervision of a mechanical engineer licensed in the state of Minnesota.
 - a. Drawings shall be completed prior to the start of construction and be complete and detailed.
 - b. Design by installer is not an acceptable approach,
 - c. Intent is to demonstrate that which will be installed for approval prior to the start of construction and not to document that which was constructed.
 - d. Drawings shall include all mechanical devices and general project information including a load summary.
 - e. Drawings shall include all heating, cooling, water and air calculations.
 - f. Contractor shall provide training and orientation to the owner for all systems.
 - g. Bidding: Process shall be coordinated and verified with all other entities involved in the construction of this facility. This shall include but not be limited to architectural, civil, structural and other contract documents, electrical, telephone, cable television and other utilities and all other contractors. Coordination with all entities whose involvement is known and who are available shall be a contractual obligation.
- d. All fees, permits, licenses, taxes, utility charges, etc., necessary to complete the mechanical installation shall be included.

15020 CODES AND LICENSES

1. Each respective Mechanical Contractor or Subcontractor shall maintain necessary city and state licenses and shall instruct all work to be in conformance with all applicable codes such as State Building, Mechanical, Energy and Plumbing Codes, NFPA, NEC, Green Communities, etc.

15030 GUARANTEES AND TESTS

1. The Contractor shall guarantee the proper operation of all components of the mechanical system, both materials and labor, for a period of one year after Substantial Completion Date on G704. The guarantee period for air conditioning system shall start upon the day that the Contractor starts the air conditioning system and shall run for a full year from that date.
2. The Contractor shall be responsible for all tests such as air pressure tests, hydronic pressure test, compaction tests, etc. as necessary to assure leakproof piping systems throughout the building. This will include all systems including, but not limited to, plumbing water, plumbing waste and vent, gas piping, heating water piping, exterior piping, etc. Where applicable, the Contractor shall furnish the Owner certification of proper tests and acceptance by the Local Official.

MECHANICAL REQUIREMENTS BASIS OF DESIGN & SYSTEMS NARRATIVE

3. All piping shall be cut to measured fit on the job and shall be installed parallel to walls and ceiling and to properly clear all openings and provide necessary clearances for the operation of doors, windows, access panels, valves, etc. All changes in direction shall be made with fittings except bends will be permitted in soft temper tubing. Piping shall be concealed in shafts, wall chases, spaces or furrings provided except in equipment rooms. Unions shall be provided where required for disconnection and to facilitate quick repair without dismantling long lengths of piping. Install valves and unions at each piece of equipment, outlet and fixtures. Slope all building sanitary sewer and mains at 1/4" per foot minimum and branch piping at 1/4" per foot minimum unless noted otherwise. Verify starting and leaving invert elevations, building slab elevations, grade elevations and city utility invert elevations.
4. All piping shall be installed to properly clear all opening through framing members and other building components in a manner that will allow for settling, shrinking, expansion and contraction of the building or building components, and movement in the piping systems. Piping shall be centered in bored holes and other openings provided for the passage of piping. Piping shall be properly supported. However, piping supporting devices or methods shall not interfere with the ability of piping to expand, contract or otherwise move with the building.
5. Protection During Construction:
 - a. All pipe openings shall be closed with metal plugs or caps during construction. The plugs or caps shall be installed with the piping as it is roughed-in, and shall not be removed until the final connection is made. The interior of all pipe shall be kept free of cuttings, dirt, scale and loose materials of any nature.
 - b. All plumbing fixtures and trim, equipment, piping and supports shall be protected against any and all damages incidental to all phases of construction.
 - c. All leaks and damages caused by disconnected pipes, fittings and overflow of fixtures in the temporary or permanent systems shall be the responsibility of the Contractor.
6. Dielectric Unions: Provide dielectric unions or brass couplings and fittings where pipes of dissimilar materials are jointed.
7. Unions & Flanges: Provide at pipe connections to all fixtures, equipment, etc.
8. Swing Joints: Provide swing joints to allow for expansion at risers or branch to system components.
9. Vacuum breakers shall be installed in all water pipes feeding hose connections or fixtures with submerged inlets.
10. Heat Piping: Pitch piping upward in direction of flow, 1" per 40 ft. Install drain cocks at low points and manual air vents at high points. Where points are inaccessible, extend vent to an

MECHANICAL REQUIREMENTS BASIS OF DESIGN & SYSTEMS NARRATIVE

accessible area; see "access panels" in this section.

11. Hangers and supports shall conform to the latest edition of the "Manufacturer's Standardization Society of the Valve & Fitting Industry." "MSS Standard Practices."
12. Where pipes are not insulated, provide plastic isolation between hanger and pipe, Hydra-Zorb or approved equal.
13. Thoroughly clean all equipment such as strainers, motors, fans, coils, units, burners, etc. after completing system installation.
14. Furnish all equipment with finish paint unless otherwise specified. Refinish and restore to the original condition and appearance, all mechanical equipment that has sustained damage to the manufacturer's prime and finish coats of enamel or paint.
15. Mechanical Contractor shall periodically remove waste and rubbish and maintain order in regards to his work. Premises shall be left clean and free of debris and unused construction materials before acceptance.
16. Mechanical Contractor shall replace all filters in systems after final cleaning of building.

15040 BALANCING

1. The Contractor shall perform necessary testing, adjusting, and balancing of the water and air distribution systems and temperature control equipment as required to assure efficient and proper operation of the systems. The Contractor or Subcontractor performing the testing and balancing shall be certified with the American Association of Balancing Contractors.

15050 ACCESSORY MATERIALS

1. This Contractor shall provide and install all required sleeves, hangers, supports, closure plates, access panels, and firestopping for a complete and professional installation.

15060 EXCAVATION AND BACKFILL

1. This Contractor or Subcontractor shall be required to perform all excavation, backfill, and compaction as required for the installation of mechanical items below the floor and to a point of connection with the main in the street (storm, sanitary, water, etc.). Compaction shall be performed with mechanical or hand compactors in layers 8" thick or less.

15070 CUTTING AND PATCHING

1. This Contractor shall provide cutting and patching as required for the installation of his equipment in the building walls, partitions, floors, ceilings, etc.

MECHANICAL REQUIREMENTS BASIS OF DESIGN & SYSTEMS NARRATIVE

15080 INSULATION

1. All domestic water and recirculating hot water, cooling, and heating piping shall be covered with flexible, closed-cell, polyethylene thermal insulation with a perm rating of less than .01 suitable for pipe service temperature from -90 degrees F to +212 degrees F, thickness to meet the Minnesota Energy Code. All domestic cold water piping and condensate piping shall be covered with ½” insulation to prevent condensation. Insulate refrigerant and condensate piping as per code and to prevent condensation.
2. Supply ductwork for all public areas ventilation with air conditioning shall be lined with 1” thick 1.5 lb. density internal liner applied with welded pins approximately 12” on center. Mixed air and outside air ductwork shall be lined similarly with 1” thick 1.5 lb. density insulation. Return plenums and return ductwork from plenum to 8’-0” upstream for units serving public spaces shall be lined similarly with 1” thick 1.5 lb. density insulation. Exhaust ducts in attic shall be insulated in attic and to 4’ below top floor ceiling. Side wall exhaust ducts shall be insulated 6’ upstream of wall cap. Provide temperature rated insulation as required for exhaust ducts in truss space. Equivalent exterior insulation is acceptable for round ductwork.

15090 EQUIPMENT IDENTIFICATION

1. Major runs of plumbing and heating piping shall be identified approximately 20 ft. on center with plastic snap-on labels or 1” high stenciled letters. Supply air units, exhaust fans, pumps, boilers, etc. shall be labeled with engraved black and white plastic laminate plates, 1” high letters.

15100 PIPE MATERIALS

1. All piping shall be constructed in conformance with local plumbing, fire sprinkle, and heating standards utilizing materials acceptable to the city departments as follows:

Water Service	Ductile iron pipe
Domestic Water	Type L Copper with 95-5 solder, Galvanized Steel, PEX-A, or CPVC
Waste Below Floor	PVC or Cast Iron
Waste Above Floor	PVC or Cast Iron
Vent Pipe Above Floor	PVC with solvent weld joints
Gas Pipe	Schedule 40 black steel, Copper or CSST
Hot Water Heating	Schedule 40 black steel, PEX-A, or Type L Copper
Condensate Pipe	PVC with solvent weld joints

15110 VALVES

1. Valves shall be brass and furnished and installed at locations as required to provide adequate service to equipment and specific portions of the facility. Where valves are used for shutoff

MECHANICAL REQUIREMENTS BASIS OF DESIGN & SYSTEMS NARRATIVE

service; ball valves with necessary backflow preventers shall be provided. Ball valves shall be full port. Provide shut-off valves for isolation on all branch piping.

2. Provide a numbered two-color engraved plastic tag or stamped brass tag approximately one (1) inch in diameter, attached to handle of each valve with non-rusting "S" hook of adequate size. Local stop and shut-off valve to an equipment item need not be tagged.
 - a. Engrave each tag with number and service designation of valve. Prefix numbers with "C" for cold water and "H" for hot water. In color-coded lines, background plastic color shall correspond to service identification color.
 - b. Where valves occur above lay-in ceilings fasten 3/4" square plastic marker to panel below valve. Marker shall have white background with black engraved letters and numbers identifying valve concealed above.

15120 EXPANSION COMPENSATION

1. Piping runs throughout the building, where long enough to develop stresses due to thermal expansion shall include pipe loops properly sized and located on the drawings. The loops shall include anchors and guides as necessary.

15130 PLUMBING ACCESSORIES

1. Where necessary for a complete system, the Contractor shall furnish and install floor drains, cleanouts, roof drains, roof jackets, unions, vacuum breakers, shock absorbers, access covers, dielectric fittings, etc.
2. Provide cast iron floor drains with nickel bronze strainers at the following locations:
 - a. All public toilet rooms.
 - b. At air handling units for condensate.
 - c. At clothes washers.
 - d. Mechanical rooms.
 - e. Apartment garage. Non-trapped floor drains with cast iron strainer at 40' spacing.
 - f. Elevator pit, non-trapped. Pipe to a sump basin with simplex sump pump. Pipe the discharge indirectly to sanitary sewer system. System must be sized to meet the MN Elevator Code.
3. Furnish and install water softening system for the hot and cold water as manufactured by Water Control Corporation, R.B. Hill; Marlo, Inc.; Culligan; Bruner; or approved equal. Provide separate hard water line to supply to supply the exterior hose bibbs. The automatic control will include a meter located on the outlet side of water softener. The meter will be directly connected to the controller. Unit shall be sized at 7 psi drop through the unit. Water softener shall have outside fill pipe at location designated by owner.

MECHANICAL REQUIREMENTS BASIS OF DESIGN & SYSTEMS NARRATIVE

4. Furnish and install Weil, Meyers, or approved equal sump pumps. Units shall be completely factory assembled, packaged and factory wired including a single source power connection. Units shall be U.L. labeled or wired in accordance with the National Electric Code. Each pump shall be equipped with a check valve and a gate valve arranged to allow serviceability of the pumps and valves. Single pump units shall be controlled by a single float switch to cycle pump "ON-OFF." In addition, a float switch set at a higher level and wired to an alarm panel shall be provided. Alarm panel shall have an audible alarm horn, alarm light, and a reset button. Sump basins shall be fiberglass or steel type with steel cover. Basin shall have inlet and outlet openings arranged according to specific job site conditions. Provide a minimum depth of 36" below the inlet pipe invert elevation. Steel cover shall bolt to basin with a gas tight seal and shall have access plates for pump servicing, vent and discharge pipe openings. Provide anti-floatation ring to restrain sump basin from floating up, make arrangement with mason to provide concrete ballast. Provide separate pump and pit for elevator floor drain, elevator drain tile and for building drain tile.
5. Furnish and install a flammable waste trap. Provide a manufactured flammable trap as manufactured by Minneapolis Tank Company or approved equal. Trap shall be 42" in diameter and depth determined from drawings and site conditions with holding capacity of 35 cubic feet. Material shall be 3/16" thick steel plate with corrosion resistant coating painted on the inside and outside of the tank.
6. Access panels for access to mechanical systems and piping must be provided and installed by the mechanical contractor. Coordinate with architect to determine approved locations and finishes.
7. For each building, furnish and install 1-1/2" irrigation meter with RPZ and pipe to exterior of building. Connect to hard water pipe at water service entrance.
8. Water Hammer Arresters shall meet standard: ASSE 1010 or PDI-WH 201 and provided as per code.
9. Backwater valves shall be cast iron and meet standard: ASME A112.14.1.
10. Rough in for tenant water meters on each hot and cold water tap to each individual tenant according to the manufacturer's recommendations. Meters and monitoring provided by Utility Management Solutions, (952) 934-4346, www.utilitymanage.com.
11. Provide thermostatic mixing valves at all public lavatories, standard ASSE 1017.

15140 PLUMBING FIXTURES

1. Contractor shall furnish and install all necessary plumbing fixtures of types as follows, surfaces in contact with walls, floors or countertops shall be caulked with silicon sealant. All faucets and fixtures shall be WaterSense Labeled. Water closets shall be Niagra Ecologic. Sinks, showers and bathbays shall be American Standard, Kohler, Toto, Elkay, Dayton, Just,

MECHANICAL REQUIREMENTS BASIS OF DESIGN & SYSTEMS NARRATIVE

Aquatic, Universal Rundle, or equal. Faucets shall be Delta, American Standard, Pfister, Moen or equal. All units shall meet HUD & FHA use of material bulletin #73.

2. Lavatories shall be cultured marble with integral bowl by General Contractor. Provide Delta water sense labeled with polished finish single lever mixing faucet, 0.5 gpm. Provide polished chrome finish grid strainer drain for public lavatories and pop-up drain for private lavatories. Provide insulated covers on traps and supplies for accessible units.
3. Water closets shall be Niagra Ecologic, comfort height, floor set, tank type, 1.28 gpf, siphon jet, vitreous china fixtures, two piece toilet with a seat height of 17-19". Provide floor set, flush tank, 1.28 gpf, elongated water closets with white open front seat for public areas.
4. Janitor's receptors shall be floor set 24" x 24" x 10" molded stone basin with vacuum breaker type mixing faucet and 4 ft. hose.
6. Counter sinks shall be stainless steel (20 gauge) sink with 1.5 gpm, water sense, Delta single lever mixing high arc faucet and matching basket strainer.
7. Lawn faucets shall be freeze-proof self-draining type. Provide faucets at 100 foot spacing around exterior of apartment building. Provide faucets with loose key tee handle and connect to hard water piping.
8. Interior hose bibbs shall be provided in the garage. Provide faucets at 100 foot spacing. Provide faucets with loose key tee handle.
9. Showers and combination tub/showers shall be one piece fiberglass with integral surround. Provide Delta single handle, polished chrome, pressure balance, scald guard, mixing valve and 1.5 gpm shower heads. Provide 72" hose, hand shower, combination grab bar/slide bar, wall hook and vacuum breaker at ADA units. Shower heads shall be WaterSense Labeled. Tub spouts shall be threaded, slip on spouts are not allowed.
10. Provide Guy-Gray 16 gauge wall box with shut-off valves, shock arrestor and drain connection for each clothes washer.
11. Provide Guy-Gray 16 gauge wall box with shut-off valve for each refrigerator. Provide flexible stainless steel connection to refrigerator.
12. All fixtures shall be furnished with ¼ turn Kohler, Brasscraft, or approved equal polished chrome stop valves with polished chrome supply tubes. Provide basket strainer assembly for all sinks, unless otherwise noted. All private lavatories shall be furnished with metal pop-up drain assembly and all public lavatories shall be furnished with metal open grid strainer drain assembly. Provide all tail pieces, traps, continuous waste assemblies and piping required; polished chrome unless otherwise noted.
13. Furnish and install floor drains with nickel bronze strainers in all furnace and mechanical rooms. Provide disaster pan with drain with chrome strainer at all clothes washers.

MECHANICAL REQUIREMENTS BASIS OF DESIGN & SYSTEMS NARRATIVE

14. Furnish and install cast iron floor drains with ductile iron strainer in common garage. Provide flammable waste tank and associated waste and vent piping.

15150 GENERAL DESIGN GUIDELINES

1. General

- a. This Section includes the Schematic Description of Mechanical systems and materials.

2. Codes and Standards

- a. Minnesota Rules Chapter 1305, 2020 Minnesota State Building Code
- b. Minnesota Rules Chapter 1346, 2020 Minnesota Mechanical Code and Fuel Gas Code.
- c. Minnesota Rules Chapter 4714, 2015 Minnesota State Plumbing Code
- d. Minnesota Rules Chapter 7511, Minnesota Fire Code.
- E. Minnesota Rules Chapter 1323, 2015 Commercial Energy Code.
- F. Green Communities, 2019 MFHA Minnesota Overlay and Guide to the 2015 Enterprise Green Communities Criteria.
- G. City of Maple Grove - Green Building Policy (The project shall comply with the administrative and submittal requirements of the City of maple Grove Green Building Policy)
- H. HVAC System Design Conditions. Mechanical Engineer shall provide heat loss/gain calculations in accordance with Manual J and S for the sizing of all equipment. Provide calculations showing compliance with ASHRAE 62.2-2010.

1. Outdoor Design Conditions - (Minnesota Energy Code, 1323.0403, Table C403.2.1)
 - a. Summer: 88°F DB/72°F WB
 - b. Winter: -15°F DB
2. Minimum Outside Air Ventilation per Minnesota Mechanical Code.
3. Minimum Exhaust Air Rates: per Minnesota Mechanical Code.
4. Maximum noise criteria per acoustical consultant criteria.
5. Space Design Criteria:

Space	Temperature		Humidity		Filtration (MERV)	Press. (P,E,N)	Noise (NC)	Exhaust	People Density (ft2/per)
	Sum	Win	Sum	Win					
Amenity	75°	70°	50%	-	8	P	30 - 35	-	50

MECHANICAL REQUIREMENTS BASIS OF DESIGN & SYSTEMS NARRATIVE

Office/Business Center	75°	70°	50%	-	8	P	25 - 30	-	100
Corridor	75°	70°	50%	-	8	P	30 - 40	Yes	-
Dwelling	74°	72°	50%	-	8	P	25 - 30	Yes	-
Fitness	68°	68°	50%	-	8	E	30 - 35	Yes	25
Janitor Closet	76°	70°	50%	-	8	E	35 - 45	Yes	-
Electrical	82°	-	-	-	8	E	40 - 50	-	-
Amenity Bathrooms	75°	70°	50%	-	8	E	30 - 35	Yes	-
Communication	82°	-	-	-	8	E	40 - 50	-	-
Elevator Shaft	85°	70°	-	-	8	E	-	-	-
Vestibule	-	65°	-	-	-	E	40 - 50	-	-
Mechanical Rooms	-	65°	-	-	-	E	40 - 50	-	-
Stairwell	-	65°	-	-	-	E	40 - 50	-	-
Parking Garage	85°	55°	-	-	-	N	45 - 55	Yes	-

NOTE: Any spaces not listed above must be design per ASHRAE Standards NOTE: Final noise criteria shall be determined by the acoustic consultant report.

15160 DOMESTIC HOT WATER HEAT

1. The apartment domestic water heating system shall utilize a minimum of two sealed combustion domestic water heaters (92% high efficiency, 0.77 EF). Provide all bronze, 9 gpm, 10' head, domestic water circulating pump with 24 hour / seven day electronic timeclock.

15170 BOILERS

1. Mechanical Contractor shall furnish and install a minimum of two natural Gas Fired Lochinvar Knight condensing hot water boilers. Units shall be complete with boiler fittings and automatic controls. The boilers (with all wiring) shall be completely factory assembled as a self-contained unit. Boilers shall also comply to CSD-1 Code requirements.
2. The boilers shall have no minimum flow requirements or minimum return water temperature requirements. Adequate openings shall be provided for access to the water side of the boiler.
3. Provide exhaust and intake pipes to the outside of the building.

MECHANICAL REQUIREMENTS BASIS OF DESIGN & SYSTEMS NARRATIVE

4. All controls are to be panel mounted and so located on the boiler as to provide ease of servicing the boiler without disturbing controls. All controls shall be mounted and wired according to A.G.A./C.G.A. requirements. Electric power supply 120 volts, 60 cycle single phase. Boilers shall automatically modulate the burners and sequence based on load.
5. Provide thermostat on inlet and outlet of boilers. Provide pressure gauge at boilers.

15170 HEATING PIPING SPECIALTIES

1. The heating piping system shall include all interconnecting piping and accessories as required for an easy to maintain system including manual air vents as high points in the piping system, pipe strainer, thermometers, pressure gauges.
2. Provide connection for domestic water heat exchangers.

15180 HOT WATER HEATING

1. The Mechanical contractor shall furnish and install hot water cabinet unit heaters at each entry and at the base of each stairwell.
2. Fin tube radiation shall be Slant Fin HD Series with 16 gauge cover. Provide one 24 volt control valve and wall mounted programmable thermostat per apartment. Provide thermostats with 7-day programmable functionality, internet connectivity and “learning” capabilities.
3. Provide hot water unit heaters in garage.

15190 ELEVATOR EQUIPMENT ROOM

1. The Mechanical contractor shall furnish and install high wall mini split air conditioner with condensate piping to floor drain.
2. Furnish and install remote condensing unit and refrigerant piping.
3. Provide elevator shaft smoke vent with motorized damper.

15200 FURNACES

1. The Mechanical Contractor shall furnish and install energy star 95% minimum efficiency condensing furnaces with single speed blower, DX coil, refrigerant piping, 1” disposable filters and condensate to floor drain. Condensing units shall be energy star with a minimum of 14.0 SEER. Provide economizer for units as required by code. Provide fresh air with motorized damper to each furnace as per code. Thermostat with auto changeover, 7-day programmable functionality, internet connectivity and “learning” capabilities.
2. The public area units shall evenly distribute the air through the space and wash the glass to prevent condensation. Sizing of units shall be as required.

MECHANICAL REQUIREMENTS BASIS OF DESIGN & SYSTEMS NARRATIVE

15210 DUCTWORK

1. The Mechanical Contractor shall furnish and install accessories in the ductwork system as required for proper operation of the system including access doors, louvers, fire dampers, motorized dampers, backdraft dampers, flex connections, duct turns, and balancing dampers (installed at branch takeoff locations not at diffuser locations) as required to permit satisfactory balance and control of the distribution.
2. Insulate all ductwork as required to prevent condensation, control sound and meet the energy code.
3. All duct joints shall be sealed with mastic.

15220 GRILLES, REGISTERS, AND DIFFUSERS

1. The Mechanical Contractor shall furnish and install all necessary grilles, registers, and diffusers as required to evenly distribute the airflow through the spaces. Grilles, registers, and diffusers shall be compatible with ceiling type and shall be ducted on both supply and return. Floor grilles shall be extruded aluminum with necessary floor strengthening bars and heavy duty frame and shall have an anodized finish. Wall grilles and registers in public spaces shall be extruded aluminum with an anodized finish of a color selected by the Architect. Ceiling grilles and registers installed in gypsum board in public spaces shall be extruded aluminum with an anodized finish of a color selected by the Architect.

15230 TOILET EXHAUST FANS

1. Energy Star two speed, low noise exhaust fan (less than one sone) similar to Panasonic Whisper series.
2. Fan operation continuous at 25 cfm, high speed via light switch with humidistat and timer, or other control as per AH Green Communities Criteria Item 7.1.
3. Fan to be located in wall of toilet room and ducted up to within the floor assembly to a wall cap at the exterior wall, except on the top floor the exhaust fan should be vented through the roof with relief hood.
4. If exhaust fan is located in ceiling or rated assembly a radial damper and/or rated box will be required to maintain ceiling rating.
5. Furnish and install metal wall cap with bird screen for each fan. Wall cap color shall be selected by Architect to match building.
6. Furnish and install 100 cfm lone sone exhaust fan in Maintenance Room 014. Provide fan with radiation damper and 6" round duct to wall cap on outside of building.

MECHANICAL REQUIREMENTS BASIS OF DESIGN & SYSTEMS NARRATIVE

15240 DRYER EXHAUST

1. Exhaust shall be ducted from the dryer to a wall cap at the exterior wall of the dwelling unit. Duct work must be rigid ductwork with fire wrap insulation per code.
2. Provide transfer air grilles in wall above door to laundry closet for dryer makeup air.
3. Furnish and install metal wall cap without damper or bird screen for each dryer. Wall cap color shall be selected by Architect to match building.

15250 RANGE HOOD EXHAUST

1. Exhaust shall be ducted from the range hood to a wall cap at the exterior wall of the dwelling unit. Duct work must be rigid ductwork with fire damper per code.
2. Furnish and install metal wall cap with bird screen for each hood. Wall cap color shall be selected by Architect to match building.

15260 GAS SERVICE & DISTRIBUTION

1. Make arrangements with the local gas company and pay all costs and fees for firm gas service including gas meter with shut-off valve on each side of the meter. Provide a main gas shut-off valve at the first accessible point with-in the building; provide a tag identifying location when valve is concealed.
2. Furnish and install gas piping to furnaces, water heaters, appliances, boilers, etc.
3. Provide a shut-off valve and approved gas pressure regulator at each appliance or unit of equipment. Vent gas pressure regulators as required.

15270 ELECTRICAL REQUIREMENTS

1. All motors shall be furnished with mechanical equipment by Mechanical Contractor and shall conform to the Standard Specifications of NEMA and shall bear nameplate of manufacturer, with current and operating characteristics thereon.
2. Disconnects, Starter/Overload, Controls
 - a. Disconnects, magnetic motor starters and/or overload protection shall be furnished, installed and wired by the Electrical Contractor unless otherwise noted. All magnetic motor starters shall be equipped with overload protection. Mechanical Contractor shall furnish all single-phase motors with built-in overload protection.
 - b. Mechanical Contractor shall furnish complete wiring diagrams to Electrical Contractor upon request. Control valves and motorized dampers including damper operators shall be field installed by the Mechanical Contractor unless otherwise specified.

MECHANICAL REQUIREMENTS BASIS OF DESIGN & SYSTEMS NARRATIVE

- c. Refer to electrical contract documents and coordinate with Electrical Contractor as required for proper installation and operation to comply with all codes and the sequence of operation.
 - d. All control valves shall be installed in piping by the Mechanical Contractor.
3. Motors:
- a. Motors supplied under the mechanical contract shall be set in place by the Mechanical Contractor unless otherwise noted.
4. Wiring:
- a. Furnish all thermostats, transformers, PE or EP switches, relays, etc., that are related to the operation and control of his equipment and/or his work. Mechanical Contractor shall assume all costs and responsibilities for the installation and wiring of these devices unless otherwise noted. Electrical Contractor will do all power wiring (more than 30 volts) to mechanical equipment, including any wiring and/or installation of components such as disconnects, starters, etc. which are not factory wired and/or installed. Mechanical Contractor shall furnish and install all control wiring (30 volts or less).
 - b. Notify the Electrical Contractor of any changes in mechanical equipment horsepower.
 - c. All wiring done in connection with mechanical systems and equipment shall be installed to meet the requirements of Division 16000, Electrical.
5. Wiring Diagrams:
- a. Complete wiring diagrams for all mechanical equipment, systems and controls shall be furnished by the Mechanical Contractor or the Mechanical Contractor's equipment supplier.

15280 FIRE PROTECTION SYSTEMS

1. Water Service Entrance
- a. 6" Fire Protection water service will be provided from the Municipality's nearest utility water main to the building. Fire Protection water service shall have a backflow preventer furnished and installed per the local requirements.
2. Fire Department Connection
- a. A fire department connection shall be installed at a location determined by architect and verified by local Fire Marshal. Verify exact location, type, and mounting height with local Fire Marshal. See drawings for location.

MECHANICAL REQUIREMENTS BASIS OF DESIGN & SYSTEMS NARRATIVE

3. Sprinkler System
 - a. Sprinkler system will NFPA 13R for the building areas. Provide dry sprinkler system for areas subject to freezing.
 - b. Sprinkler zones established according to occupancy classifications.
4. Refer to the architectural code plan to confirm all code related items.
5. Sprinklers will be quick response or residential types. Extended coverage type wherever possible. Extended coverage sprinklers will be identical in appearance to standard coverage sprinklers.
7. Sprinklers will be located in a regular pattern, perpendicular and parallel with building lines, and in perfect alignment with other ceiling components. Sprinklers will be installed in the center of acoustical ceiling tiles, and no closer than 4 inches from any ceiling edge or other ceiling component.
8. Sprinkler application will be:
 - a. Finished areas will be quick response, semi-recessed white sprinklers.
 - b. Sprinklers in unfinished areas will be pendent, upright or sidewall types suitable for the application.
6. Sprinklers in areas subject to freezing including entry vestibule, trash chutes, garage entry and near area wells will be semi-recessed pendent or sidewall, dry-type sprinklers.

END OF SECTION

**ELECTRICAL SYSTEMS SUMMARY BASIS OF DESIGN
FOR
BOTTINEAU RIDGE APARTMENTS
MAPLE GROVE, MN**

ELECTRICAL REQUIREMENTS BASIS OF DESIGN & SYSTEMS NARRATIVE

16010 GENERAL PROVISIONS

1. Scope: The project consists of a 50 Unit Apartment building with 4 levels of living units/common spaces and 1 level of parking under in the lowest level with elevator.
2. The limits of construction shall include electrical and telephone/communications/CATV systems designed as outlined by this summary for a “stand-alone” building serving dwelling units, Lobby/Club/Amenity Areas, indoor parking level and site area.
3. This document was prepared to give a general scope of electrical work to obtain electrical pricing. Electrical pricing shall include all lighting, service equipment, fire alarm, controls, terminal devices, etc. necessary for complete systems.
4. This document is not to be construed to be a complete design or used for city submittals. The specifications covering the Electrical System are performance in nature and are not Certified Engineering complete in every detail. These specifications are intended to assist the Contractor in determining the scope of the work, systems to be installed, and to indicate the approximate locations with respect to other electrical systems.
5. Project to be constructed on a design build basis for which the design build electrical contractor shall assume full responsibility for the resulting electrical systems and their implementation. The requirements of this summary are minimum requirements with the design build electrical contractor fully responsible for the resulting installation.
6. The design build electrical contractor shall provide complete detailed electrical drawings and equipment specifications for the complete installation certified by and completed under the supervision of an electrical engineer licensed in the state of Minnesota.
 - a. Drawings shall be completed prior to the start of construction and be complete and detailed.
 - b. Design by installer is not an acceptable approach,
 - c. Drawings shall include all electrical devices and general project information including a load summary.
 - d. Site plan with all electrical and lighting systems, including foundations and photometric information depicted in detail.
 - e. Motor/equipment connection, panel board, switchboard, light fixture and similar schedules.
 - f. Line voltage drawings with every device individually circuited.
 - g. Riser diagram with all feeders sized and equipment accurately depicted.
 - h. Systems risers including but not limited to fire alarm.
 - i. Contractor shall provide training and orientation to the owner for all systems.
 - j. Provide temporary electrical service, lighting and power as needed.
 - k. Systems Analysis: Electrical contractor or their consultant shall complete a systems analysis including a coordination study and short circuit analysis and provide all information necessary to complete and document all code and AHJ required systems analysis and labeling.

ELECTRICAL REQUIRMENTS BASIS OF DESIGN & SYSTEMS NARRATIVE

7. Bidding: Process shall be coordinated and verified with all other entities involved in the construction of this facility. This shall include but not be limited to architectural, civil, structural and other contract documents, electrical, telephone, cable television, internet, satellite and other utilities and all other contractors. Coordination with all entities whose involvement is known and who are available shall be a contractual obligation.
8. All fees, permits, licenses, taxes, utility charges, etc., necessary to complete the electrical installation shall be included.
9. Per Bottineau Ridge (MG) Green Communities Criteria 5.1a., The Project will retain a HERS rater to certify the dwelling units.

CODES AND LICENSES

1. Each Contractor shall maintain necessary licenses and shall instruct all work to be in conformance with all applicable codes such as:
 - a. National Electrical Code
 - b. State and Local Electrical Codes
 - c. Institute of Electrical and Electronic Engineers
 - d. National Board of Fire Underwriters
 - e. National Electrical Manufacturer's Association
 - f. Underwriter's Laboratories
 - g. NECA Standard of Installation
 - h. NECA 1 Good Workmanship in Electrical Construction
 - i. AIA/FGI Guidelines
 - j. MN Energy Code with amendments
 - k. Illuminating Engineering Society (recommendations)
 - l. Green Communities, 2019 MHFA Minnesota Overlay and Guide to the 2015 Enterprise Green Communities.
 - m. City of Maple Grove – Green Building Policy (The project shall comply with the administrative and submittal requirements of the City of Maple Grove’s Green Building Policy).

GUARANTEE AND TESTS

1. Guarantee the proper operation of all components of the electrical system, both materials and labor, for a period of one year after substantial completion as certified by AIA Form G-704.

ACCESSORY MATERIALS

1. Install all required sleeves, hangers, supports, closure plates, access panels, and fire stopping for complete and professional installation.

CUTTING AND PATCHING

1. Provide all cutting and patching as required for the installation of equipment.

MATERIALS AND METHODS

1. All materials shall be new, of good residential and commercial quality (as applicable) and made by approved manufacturers. Materials shall conform to all applicable codes and regulations.

ELECTRICAL REQUIRMENTS BASIS OF DESIGN & SYSTEMS NARRATIVE

2. All wiring shall be in wire in metal conduit or a flexible type of cable such as NM if allowed by code.
3. Wire and cable shall be NEC standard 600 volt copper conductors. Branch circuit conductor sizes shall be #14 minimum. For service entrance and feeder conductors, #4 or larger aluminum conductors having the specified insulation may be substituted for the copper conductors. Elevator conductors shall be copper.
4. Proper grounding shall be provided for all electrical systems and equipment.
5. House panels shall be panelboard construction, panels located within Dwelling Units shall be load center construction.
6. Safety switches shall be of fused heavy duty.
7. Switches, receptacles, and devices shall be specification grade.
8. All wiring shall be concealed.

IDENTIFICATION AND LABELING OF ELECTRICAL EQUIPMENT

1. All circuit protective devices, relays, motor starters, and control stations shall be clearly labeled so as to identify the voltage, the function of the control and the equipment controlled or the circuit protected; snap switches within sight of fixtures controlled shall not be labeled. Identifying terminology for circuits shall indicate the equipment or the location served.
2. All labeling shall be legible, explicit and permanent. In panelboards of the lighting type, the circuit directory shall be typewritten. Switches, manual starters and other flush devices shall be labeled by engraving the associated wall plates. All other labeling, including labeling for circuit protective devices in distribution panelboards and switchboards shall be done by the use of individual legend plates or nameplates.

MOUNTING HEIGHTS

1. Height of wall outlets and device boxes measured from finished floor to the center, top or bottom of the outlet shall be as follows unless noted otherwise on the Architectural Drawings or Electrical Drawings. All mounting heights shall be in accordance with ADA requirements. Height of wall outlets and device boxes at counters shall be nine inches above finished work area.

	TYP UNITS	HC UNITS	PUBLIC AREA
Receptacles (Center)	18"	18"	18"
Light Switches (Center)	48"	48"	48"
Thermostats (Center)	54"	48"	48"
Wall Mounted Telephone (Center)	54"	48"	48"
Telephone Receptacle (Center)	18"	18"	18"
Panelboard (Top)	48" (top C.B)	48" (top C.B)	72"
Smoke Detectors	Clng.	Clng.	Clng.

ELECTRICAL REQUIRMENTS BASIS OF DESIGN & SYSTEMS NARRATIVE

Receptacle Over Counter (Bottom above backsplash)	2"	2"	2"
Fire Alarm horn (Center)	88"	88"	88"
Fire Alarm Horn/Strobes (Center)	88"	88"	88"
Fire Alarm Pullstation (Center)	48"	48"	48"
ADA Sconce (Center)	72"	72"	72"
Emergency Light (Center)	88"	88"	88"
Fire Alarm Panel (Top)	N/A	N/A	72"
Remote Fire Alarm Panel (Center)	N/A	N/A	54"
Lighting Control Panel (Top)	N/A	N/A	72"

16040 ELECTRIC SERVICE AND DISTRIBUTION

1. Apartment Building: The building shall be served by one 120/208/3, 1200Amp service with individual utility dwelling unit meters and one 120/208/3, 600Amp house/CT meter. Each Dwelling unit shall be served by a 120/208/1, 100Amp panel. House service shall consist of a 120/208/3, 600amp distribution board feeding the elevator, one 120/208/3, 200 panel located in the first floor Mechanical Room and one 120/208/3, 400amp panel located garage level Mechanical Room. The main switches shall be fusible.

16045 EMERGENCY GENERATOR

1. Not Required.

16050 LIGHTING SYSTEM

1. Interior building lighting of all spaces, including, but not limited to, corridors, lobbies, vestibules, restrooms, commons areas, garage, dwelling unit apartments, and equipment and utility rooms/spaces.
2. The lighting installation throughout the building shall comply with the Energy Code listed above and the Illuminating Engineering society for recommended lighting levels.
3. All lighting shall be LED fixtures, LED retrofit type lamps may be used in dwelling units. Any fixture with LED retrofit type lamps shall have the fixture relabeled to the corresponding LED lamp wattage.
4. Furnish and install a complete lighting system including fixtures and lamps.
5. Occupancy sensors shall be located in all code required locations including but not limited to offices, corridors, storage rooms and garage.
6. Fixtures shall be LED, Energy Star/DLC Listed.
7. Furnish and install a fire rated fire box for all recessed fixtures located within an fire rated ceiling assembly.
8. Drivers for LED fixtures: To be included with solid state light fixtures. IESNA LM-79 and LM-80 compliant, 100,000 hours minimum life.
9. All dwelling unit fixtures shall be Energy Star Rated. All common space fixtures shall be Energy Star and or DLC rated.
10. Per Maple Grove (MG) Green Communities Criteria 5.5, light fixtures are to be high-efficiency lighting with at least 40-60 Lumens per watt.

ELECTRICAL REQUIREMENTS BASIS OF DESIGN & SYSTEMS NARRATIVE

11. Lumens/Watt shall meet and or exceed the current energy code.
12. Common area controls shall be Bi-Level and or 0-10V Dimming.
13. Common Areas:
 - a. Vestibules, and Entry Areas: Surface mount puck style fixture similar to Lightolier S5R/S7R series to provide a nominal 20 footcandles.
 - b. Lobby(ies), Corridors, and Common Areas: A combination of LED wall sconce lighting and surface mount puck style fixture similar to Lightolier S5R/S7R series to provide a nominal 15-20 footcandles. Some surface mounted decorative ceiling lighting shall also be used.
 - c. Stairways: Wall or ceiling mounted 4' LED fixtures mounted at each landing to provide a nominal 15 footcandles. A reduced lighting level will be provided based on occupancy sensor integral to the fixtures. The minimum light level shall remain at least 5 footcandles. Reduced light level to be achieved through dimming and fixtures shall never completely turn off. fixtures shall be similar to Metalux SRL Series with battery backup.
 - d. Accent Lighting: Additional LED accent lighting will be provided as required to accent fireplaces, water features, signage, mail boxes and other similar features.
 - e. Washrooms/Toilets/Restroom Areas: Wall and ceiling mounted LED fixtures to provide a nominal 15 footcandles at the lavatory.
 - f. Club Room: A combination surface mount puck style fixture similar to Lightolier S5R/S7R series and wall mounted LED sconces to provide a nominal 30-40 footcandles at the floor. Decorative pendant LED fixtures installed over kitchen island area. Additional LED decorative fixtures may be used at focal areas.
 - g. Utility Rooms and General Purpose Rooms: LED strip fixtures to provide a nominal 30 footcandles.
 - h. Electrical/Mechanical, Storage and Building Equipment spaces: 4' and 8' industrial LED strip luminaires to provide a nominal 30 footcandles.
 - i. Office areas: Surface 1x4 LED dimming fixtures to provide a nominal 30 footcandles.
 - j. Garage; 4'-0" or 8'-0" LED strip lights with emergency/exit lighting.
 - k. Elevator pit and machine space: Lensed 4' LED strip fixture to provide a code required 20 footcandles. Lighting controls shall be local toggle switches only.
 - l. Attic: Keyless with LED lamp every 40'-0" with a switch located at the attic access.
14. Dwelling Units:
 - a. Entry: Surface LED mount puck style fixture similar to Lightolier S5R/S7R series.
 - b. Walk In Closets: Surface LED mount puck style fixture similar to Lightolier S5R/S7R series.
 - c. Kitchen: Surface Decorative 3-Lamp with LED screw in lamps and decorative LED pendants over peninsula counter. Undercabinet LED fixture oversink with separate switches.
 - d. Bath: Wall Mount Decorative 3-Lamp with LED screw in lamps over the vanity and a Surface mount puck style fixture similar to Lightolier S5R/S7R series.
 - e. Dining Area/Room: Surface Decorative 2-Lamp with LED screw in lamps.
 - f. Living Room: Provide a ceiling fan rated box for future use with wall switch rough in.
 - g. Hallways: Surface LED mount puck style fixture similar to Lightolier S5R/S7R series.
 - h. Bedroom/dens: Surface LED mount puck style fixture similar to Lightolier S5R/S7R series.

ELECTRICAL REQUIRMENTS BASIS OF DESIGN & SYSTEMS NARRATIVE

16051 EMERGENCY LIGHTING

1. Furnish and install a complete exit and emergency lighting system as required throughout the building. Emergency/Exit lighting similar to Isolight RLC and RLLED series.
2. Per Maple Grove (MG) Green Communities Criteria 5.5, All emergency lighting exit signs shall consume 5 watts or less and fixtures located above stairwell doors will contain a battery backup.

16052 SITE LIGHTING

1. Furnish and install all site pole fixtures with concrete bases (to match Bottineau II adjacent project) and exterior building mounted fixtures.
2. Exterior lighting must provide minimum 2 footcandles at all entries. Parking Lot/Drive areas shall be illuminated with 4K LED full cut off fixtures with 20' poles.

16060 POWER

1. Furnish and install code required outlets.
2. Residential grade tamper resistant duplex receptacles shall be provided in all dwelling units, two of the outlets shall have USB connections. AFCI and or GFCI type circuit breakers shall be provided in all dwelling units as required by NEC. Provide a WP/GFI receptacle with wet location while in use coverplate on unit balconies. Provide dedicated outlet/circuit for microwave @ microwave shelf.
3. Make connections to mechanical equipment described in the Mechanical portion of this narrative.
4. Electric Vehicle Charging Stations (Apartment Garage):
 - a. Provide power for (4) Level 1 electrical vehicle charging stations fed from the panel located in Garage Mechanical Room. Provide dedicate 20 amp receptacle for each space. The car charger shall be by others. Owner to select locations.
 - c. Metering for car chargers: Provide metering system similar the E-Mon/D-Mon on each circuit to the car chargers to allow the Owner to bill out the usage for each charger to the specific user. Include billing software from meter manufacturer.
5. Make connections to other equipment provided by others, such as kitchen equipment, washer/dryers, etc.
6. Equipment located in Apartments Dwelling Units (provided by others).
 - a. Electric Range
 - b. Exhaust hood for range
 - c. Microwave hood/fan combo (Alternate)
 - d. Dishwasher
 - e. Refrigerator
 - f. Bathroom Exhaust Fan
 - g. Thru the wall A/C
7. Provide receptacles at the following locations:
 - a. Within 25 feet of mechanical equipment.

ELECTRICAL REQUIRMENTS BASIS OF DESIGN & SYSTEMS NARRATIVE

- b. GFI convenience receptacle at the entry doors of support rooms and areas, such as such as Water/Mech, Storage, Trash, Janitor and Electrical Rooms.
 - c. Stairwells, provide a receptacle at each Level.
 - d. (6) within Club Room.
 - e. (6) Counter outlets within Club Room.
 - f. (1) Vestibule.
 - g. (4) Lobby.
 - h. (3) Office.
 - i. (2) Business Center
 - j. Dedicated receptacle at each IDF closet.
 - k. Public Restrooms, provide a GFI receptacle adjacent to the sink.
 - l. Dedicated receptacles for electric water coolers.
 - m. Corridors, provide receptacles no more than 40-feet apart.
8. Provide (3) 2" conduits from the new switch gear to the roof for future photovoltaic system installation.

16071 TELEPHONE

1. Install and wire the telephone system within the building(s). Pay all charges and fees as required by the Utility.
2. Wiring shall be 24 gauge, solid conductor, 4 pair, twisted, Category 5, Level 5 plenum rated telephone cable with .032 inch thick PVC jacket.
3. Provide a 4' x 8' x 3/4" thick plywood panels painted with fire retardant paint for use by the Telephone Utility in mounting the main telephone equipment. Install a 4" empty PVC conduit out underground from main equipment to the telephone pedestal or property line. Provide one duplex convenience outlet for telephone equipment.
4. Backboard/DMARK located at 1st floor Mechanical room.
5. Provide telephone connections to other systems, such as Fire Alarm & Detection, Access Control and Area of Refuge, as required for proper operation.
6. Provide a telephone outlets in the following locations:
 - a. (1)/each dwelling unit bedroom/den.
 - b. (1)/each dwelling unit living room.
 - c. (1) Office.
 - d. (1) Business Center.

16072 CABLE TV SYSTEM

1. Furnish, install and wire the cable TV system within the building. Pay all charges and fees as required by the Utility.
2. Provide (1) 1" conduits from the garage level to the roof/attic space for future satellite dish connections with pull string.
3. Cable wire shall be RG-6 plenum rated CATV cable.

ELECTRICAL REQUIRMENTS BASIS OF DESIGN & SYSTEMS NARRATIVE

4. Backboard located at 1st floor Mechanical room.
5. Provide a TV outlet in the following locations:
 - a. (1)/each dwelling unit bedroom/den.
 - b. (1)/each dwelling unit living room.
 - c. (1) Club room.
 - d. (1) Lobby
 - e. (2) Fitness Room
 - f. (1) Club Room
 - g. (1) Management Office
 - h. (1) Business Office

16073 DATA CABLING SYSTEM

1. Furnish, install and wire the data cabling within the building.
2. Provide a 4' x 8' x 3/4" thick plywood panels painted with fire retardant paint for mounting the data punchdowns.
3. Run wiring from the data backboard to the outlets. Provide (2) separate cables from each outlet within the common spaces. Provide one cable from each typical unit Media
4. Provide 24 gauge, solid conductor, 4 pair, twisted, Category 5e, Level 5 plenum rated data cable with .032 inch thick PVC jacket.
5. Furnish and install RJ-45 patch panels EIA/TIA with 568A termination standards and wall mounting bracket for terminations of cables.
6. Provide data outlets at the following locations:
 - a. (1)/each dwelling unit bedroom/den.
 - b. (1)/each dwelling unit living room.
 - c. (1) Club room.
 - d. (2) Business Center
 - e. (1) Lobby
 - f. (1) Management Office

16074 STRUCTURED MEDIA CENTER

1. Provide a structured media center within each dwelling unit. The structured media center shall be manufactured by Leviton Series 140 with a Basic Home Networking Plus Panels, Telephone and video unit (47606-BNP) or equal.
2. Each media center shall be fed with a dedicated CAT5e cable for voice, CAT5e for data and a RG-6 plenum rated CATV cable to low-voltage backboards (Apartment Building) and or to the utility pedestal (Townhomes) via conduit.
3. Provide a 120volt duplex outlet within the bottom of the panel.

ELECTRICAL REQUIRMENTS BASIS OF DESIGN & SYSTEMS NARRATIVE

16075 TELEPHONE ENTRY SYSTEM

1. Provide/Install a complete telephone access control system for the building. The system shall consist of an entrance telephone touchpad to provide two-way voice communication between each apartment and the entrance vestibule, and to permit unlatching the security door from each apartment. Include postal lock/keypad entry.

16076 FIRE ALARM SYSTEM/AREA OF RESCUE

1. A complete fully functioning addressable fire alarm system. System shall include, remote annunciator located at the Vestibule and or a location selected by the Fire Marshal. Smoke detectors within all required areas and full coverage within the corridors. C/O detectors within all required areas. Audio/visual alarm devices to adequately cover the entire building.
2. A fire alarm horn shall be installed in each dwelling units sleeping area plus one in the living area. ADA units shall be horn/strobes with and additional strobe in each restroom.
3. Control all smoke dampers.
4. Unit smoke detectors and CO detectors shall be interlocked stand-alone type smoke detectors with battery backup. Detectors in Hearing/Vision impaired units shall be audio/visual.
5. Furnish, install and wire a complete Area of Rescue communications system. Provide annunciator, call stations at areas of refuge and wiring.
6. If required by the AHJ furnish, install and wire an Emergency Radio Communication Enhancement System (Bi-Directional Amplifier System) as manufactured by Gamewell/FCI or similar. System shall meet appendix L of the 2015 MSFC.

16077 DOORBELL

1. Provide audio/visual doorbells at all Hearing/Vision impaired units.

16078 SECURITY CAMERA SYSTEM/CCTV

1. Provide a complete Security Camera System with the following requirements:
 - a. (20) IP fixed POE indoor cameras.
 - b. (2) IP fixed POE outdoor cameras.
 - c. Cameras shall be 5MP minimum with the option to stream at 1920p, 1440p and 1080p.
 - d. DVR with 30 days of storage minimum based on motion activated cameras.
 - e. Remote access.
 - f. Choice between motion activated or continuous stream.

16080 COMERCIAL KITCHEN EQUIPMENT WIRING

1. N/A.

ELECTRICAL REQUIRMENTS BASIS OF DESIGN & SYSTEMS NARRATIVE

16085 MOTOR/EQUIPMENT WIRING

1. Provide power and control wiring, disconnects, and starters as required for all of the HVAC equipment as noted in the Mechanical Narrative.

16090 OWNERS TRAINING/MANUALS

1. Provide 8 hours of Owners training for electrical system maintenance and adjustments.
2. Provide maintenance manuals and products files to meet MFHA Overlay listed under criteria 8.1.

SECTION 01-5713 TEMPORARY EROSION AND SEDIMENT CONTROL

PART 1 GENERAL

1.1 SECTION INCLUDES

- A. Prevention of erosion due to construction activities.
- B. Prevention of sedimentation of waterways, open drainage ways, and storm and sanitary sewers due to construction activities.
- C. Restoration of areas eroded due to insufficient preventive measures.
- D. Compensation of Owner for fines levied by authorities having jurisdiction due to non-compliance by Contractor.

1.2 RELATED REQUIREMENTS

1.3 PERFORMANCE REQUIREMENTS

- A. Comply with all requirements of Minnesota Pollution Control Agency for erosion and sedimentation control, as specified for the National Pollutant Discharge Elimination System (NPDES), Phases I and II, under requirements for the 2018 Construction General Permit (CGP), whether the project is required by law to comply or not.
- B. Comply with all requirements of Shingle Creek Watershed Management Commission for erosion and sedimentation control.
- C. Develop and follow an Erosion and Sedimentation Prevention Plan and submit periodic inspection reports.
- D. Do not begin clearing, grading, or other work involving disturbance of ground surface cover until applicable permits have been obtained; furnish all documentation required to obtain applicable permits.
 - 1. Owner will obtain permits and pay for securities required by authority having jurisdiction.
 - 2. Obtain and pay for permits and provide security required by authority having jurisdiction.
 - 3. Owner will withhold payment to Contractor equivalent to all fines resulting from non-compliance with applicable regulations.
- E. Timing: Put preventive measures in place prior to disturbance of surface cover and before precipitation occurs.
- F. Storm Water Runoff: Control increased storm water runoff due to disturbance of surface cover due to construction activities for this project.
 - 1. Prevent runoff into storm and sanitary sewer systems, including open drainage channels, in excess of actual capacity or amount allowed by authorities having jurisdiction, whichever is less.
 - 2. Anticipate runoff volume due to the 25-year 24-hour rainfall design event.
- G. Erosion On Site: Minimize wind, water, and vehicular erosion of soil on project site due to construction activities for this project.
 - 1. Control movement of sediment and soil from temporary stockpiles of soil.
 - 2. Prevent development of ruts due to equipment and vehicular traffic.
 - 3. If erosion occurs due to non-compliance with these requirements, restore eroded areas at no cost to Owner.
- H. Erosion Off Site: Prevent erosion of soil and deposition of sediment on other properties caused by water leaving the project site due to construction activities for this project.
 - 1. Prevent windblown soil from leaving the project site.
 - 2. Prevent tracking of mud onto public roads outside site.

3. Prevent mud and sediment from flowing onto sidewalks and pavements.
 4. If erosion occurs due to non-compliance with these requirements, restore eroded areas at no cost to Owner.
- I. Sedimentation of Waterways On Site: Prevent sedimentation of waterways on the project site, including wetlands, rivers, streams, lakes, ponds, open drainage ways, storm sewers, and sanitary sewers.
 1. If sedimentation occurs, install or correct preventive measures immediately at no cost to Owner; remove deposited sediments; comply with requirements of authorities having jurisdiction.
 2. If sediment basins are used as temporary preventive measures, pump dry and remove deposited sediment after each storm.
 - J. Sedimentation of Waterways Off Site: Prevent sedimentation of waterways off the project site, including rivers, streams, lakes, ponds, open drainage ways, storm sewers, and sanitary sewers.
 1. If sedimentation occurs, install or correct preventive measures immediately at no cost to Owner; remove deposited sediments; comply with requirements of authorities having jurisdiction.
 - K. Open Water: Prevent standing water that could become stagnant.
 - L. Maintenance: Maintain temporary preventive measures until permanent measures have been established.

1.4 SUBMITTALS

- A. Stormwater Pollution Prevention Plan (SWPPP):
 1. Coordinate with the Engineer to finalize the SWPPP within 2 weeks after Notice to Proceed.
 2. Submit Contractor provided information to the Engineer not less than 30 days prior to anticipated start of clearing, grading, or other work involving disturbance of ground surface cover.
 3. Include:
 - a. Site plan showing grading; new improvements; temporary roads, traffic accesses, and other temporary construction; and proposed preventive measures.
 - b. Concrete washout areas
 - c. Schedule of temporary preventive measures, in relation to ground disturbing activities.
 - d. Other information required by law.
 - e. Format required by law is acceptable, provided any additional information specified is also included.
 4. Obtain the approval of the Plan by authorities having jurisdiction.
 5. Obtain the approval of the Plan by Owner.
- C. Certificate: Mill certificate for silt fence fabric attesting that fabric and factory seams comply with specified requirements, signed by legally authorized official of manufacturer; indicate actual minimum average roll values; identify fabric by roll identification numbers.
- D. Inspection Reports: Submit report of each inspection; identify each preventive measure, indicate condition, and specify maintenance or repair required and accomplished.

PART 2 PRODUCTS

2.1 MATERIALS

- A. Mulch: Use one of the following:
 1. Straw or hay.
 2. Wood waste, chips, or bark.
 3. Erosion control matting or netting.
 4. Polyethylene film, where specifically indicated only.

- B. Grass Seed For Temporary Cover: Select a species appropriate to climate, planting season, and intended purpose. If same area will later be planted with permanent vegetation, do not use species known to be excessively competitive or prone to volunteer in subsequent seasons.
- C. Silt Fence Fabric: Polypropylene geotextile resistant to common soil chemicals, mildew, and insects; non-biodegradable; in longest lengths possible; fabric including seams with the following minimum average roll lengths:
 - 1. Average Opening Size: 30 U.S. Std. Sieve, maximum, when tested in accordance with ASTM D4751.
 - 2. Permittivity: 0.05 sec^{-1} , minimum, when tested in accordance with ASTM D4491.
 - 3. Ultraviolet Resistance: Retaining at least 70 percent of tensile strength, when tested in accordance with ASTM D4355 after 500 hours exposure.
 - 4. Tensile Strength: 100 lb-f, minimum, in cross-machine direction; 124 lb-f, minimum, in machine direction; when tested in accordance with ASTM D4632.
 - 5. Elongation: 15 to 30 percent, when tested in accordance with ASTM D4632.
 - 6. Tear Strength: 55 lb-f, minimum, when tested in accordance with ASTM D4533.
 - 7. Color: Manufacturer's standard, with embedment and fastener lines preprinted.
- D. Silt Fence Posts: One of the following, minimum 5 feet long:
 - 1. Steel U- or T-section, with minimum mass of 1.33 lb per linear foot.
 - 2. Softwood, 4 by 4 inches in cross section.
 - 3. Hardwood, 2 by 2 inches in cross section.

PART 3 EXECUTION

3.1 PREPARATION

- A. Schedule work so that soil surfaces are left exposed for the minimum amount of time.

3.2 SCOPE OF PREVENTIVE MEASURES

- A. In all cases, if permanent erosion resistant measures have been installed temporary preventive measures are not required.
- B. Construction Entrances: Traffic-bearing aggregate surface.
 - 1. Width: As required; 20 feet, minimum.
 - 2. Length: 50 feet, minimum.
 - 3. Provide at each construction entrance from public right-of-way.
 - 4. Where necessary to prevent tracking of mud onto right-of-way, provide wheel washing area out of direct traffic lane, with drain into sediment trap or basin.
- C. Linear Sediment Barriers: Made of silt fences.
 - 1. Provide linear sediment barriers:
 - a. Along downhill perimeter edge of disturbed areas, including soil stockpiles.
 - b. Along the top of the slope or top bank of drainage channels and swales that traverse disturbed areas.
 - c. Along the toe of cut slopes and fill slopes.
 - d. Perpendicular to flow across the bottom of existing and new drainage channels and swales that traverse disturbed areas or carry runoff from disturbed areas; space at maximum of 200 feet apart.
 - e. Across the entrances to culverts that receive runoff from disturbed areas.
 - 2. Space sediment barriers with the following maximum slope length upslope from barrier:
 - a. Slope of Less Than 2 Percent: 100 feet..

- b. Slope Between 2 and 5 Percent: 75 feet.
 - c. Slope Between 5 and 10 Percent: 50 feet.
 - d. Slope Between 10 and 20 Percent: 25 feet.
 - e. Slope Over 20 Percent: 15 feet.
- D. Storm Drain Curb Inlet Sediment Trap: Approved drop-in sediment control device designed for the inlet size.
 - E. Storm Drain Drop Inlet Sediment Traps: As detailed on drawings.
 - F. Temporary Splash Pads: Stone aggregate over filter fabric; size to suit application; provide at downspout outlets and storm water outlets.
 - G. Soil Stockpiles: Protect using one of the following measures:
 - 1. Cover with polyethylene film, secured by placing soil on outer edges.
 - 2. Hydroseeding for erosion control.
 - H. Mulching: Use only for areas that may be subjected to erosion for less than 6 months.
 - 1. Wood Waste: Use only on slopes 3:1 or flatter; no anchoring required.
 - I. Temporary Seeding: Use where temporary vegetated cover is required.

3.3 INSTALLATION

- A. Traffic-Bearing Aggregate Surface:
 - 1. Excavate minimum of 6 inches.
 - 2. Place geotextile fabric full width and length, with minimum 12 inch overlap at joints.
 - 3. Place and compact at least 6 inches of 1.5 to 3.5 inch diameter stone.
- B. Silt Fences:
 - 1. Store and handle fabric in accordance with ASTM D4873.
 - 2. Where slope gradient is less than 3:1 or barriers will be in place less than 6 months, use nominal 16 inch high barriers with minimum 36 inch long posts spaced at 6 feet maximum, with fabric embedded at least 4 inches in ground.
 - 3. Where slope gradient is steeper than 3:1 or barriers will be in place over 6 months, use nominal 28 inch high barriers, minimum 48 inch long posts spaced at 6 feet maximum, with fabric embedded at least 6 inches in ground.
 - 4. Where slope gradient is steeper than 3:1 and vertical height of slope between barriers is more than 20 feet, use nominal 32 inch high barriers with woven wire reinforcement and steel posts spaced at 4 feet maximum, with fabric embedded at least 6 inches in ground.
 - 5. Install with top of fabric at nominal height and embedment as specified.
 - 6. Embed bottom of fabric in a trench on the upslope side of fence, with 2 inches of fabric laid flat on bottom of trench facing upslope; backfill trench and compact.
 - 7. Do not splice fabric width; minimize splices in fabric length; splice at post only, overlapping at least 18 inches, with extra post.
 - 8. Fasten fabric to wood posts using one of the following:
 - a. Four nails per post with 3/4 inch diameter flat or button head, 1 inch long, and 14 gage, 0.083 inch shank diameter.
 - b. Five staples per post with at least 17 gage, 0.0453 inch wire, 3/4 inch crown width and 1/2 inch long legs.
 - 9. Fasten fabric to steel posts using wire, nylon cord, or integral pockets.

10. Wherever runoff will flow around end of barrier or over the top, provide temporary splash pad or other outlet protection; at such outlets in the run of the barrier, make barrier not more than 12 inches high with post spacing not more than 4 feet.
- C. Mulching Over Large Areas:
1. Dry Straw and Hay: Apply 2-1/2 tons per acre; anchor using dull disc harrow or emulsified asphalt applied using same spraying machine at 100 gallons of water per ton of mulch.
 2. Wood Waste: Apply 6 to 9 tons per acre.
 3. Erosion Control Matting: Comply with manufacturer's instructions.
- D. Mulching Over Small and Medium Areas:
1. Dry Straw and Hay: Apply 4 to 6 inches depth.
 2. Wood Waste: Apply 2 to 3 inches depth.
 3. Pine Needles: Apply 2 to 3 inches depth.
 4. Erosion Control Matting: Comply with manufacturer's instructions.
- D. Temporary Seeding:
1. When hydraulic seeder is used, seedbed preparation is not required.
 2. When surface soil has been sealed by rainfall or consists of smooth undisturbed cut slopes, and conventional or manual seeding is to be used, prepare seedbed by scarifying sufficiently to allow seed to lodge and germinate.
 3. If temporary mulching was used on planting area but not removed, apply nitrogen fertilizer at 1 pound per 1000 sq ft.
 4. On soils of very low fertility, apply 10-10-10 fertilizer at rate of 12 to 16 pounds per 1000 sq ft.
 5. Incorporate fertilizer into soil before seeding.
 6. Apply seed uniformly; if using drill or cultipacker seeders place seed 1/2 to 1 inch deep.
 7. Irrigate as required to thoroughly wet soil to depth that will ensure germination, without causing runoff or erosion.
 8. Repeat irrigation as required until grass is established.

3.4 MAINTENANCE

- A. Inspect preventive measures weekly, within 24 hours after the end of any storm that produces 0.5 inches or more rainfall at the project site, and daily during prolonged rainfall.
- B. Repair deficiencies immediately.
- C. Silt Fences:
 1. Promptly replace fabric that deteriorates unless need for fence has passed.
 2. Remove silt deposits that exceed one-third of the height of the fence.
 3. Repair fences that are undercut by runoff or otherwise damaged, whether by runoff or other causes.
- D. Clean out temporary sediment control structures weekly and relocate soil on site.
- E. Place sediment in appropriate locations on site; do not remove from site.

3.5 CLEAN UP

- A. Remove temporary measures after permanent measures have been installed, unless permitted to remain by Engineer.
- B. Clean out temporary sediment control structures that are to remain as permanent measures.
- C. Where removal of temporary measures would leave exposed soil, shape surface to an acceptable grade and finish to match adjacent ground surfaces.

END OF SECTION

SECTION 02-4113 SELECTIVE DEMOLITION

PART 1 GENERAL

1.1 SECTION INCLUDES

- A. Removal of surface debris.
- B. Removal and salvage
- C. Removal and reinstallation
- D. Existing to Remain

1.2 RELATED WORK

- A. Existing to Remain
- B. Section 31-2200 – Earthwork.
- C. Section 31-5000 – Excavation Support and Protection.

1.3 REGULATORY REQUIREMENTS

- A. Comply with governing city, state and federal regulations before starting selective demolition. Comply with hauling and disposal regulations of authorities having jurisdiction.

PART 2 PRODUCTS

2.1 MATERIALS

Not used

PART 3 EXECUTION

3.1 PREPARATION

- A. Verify items designated to remain is tagged or identified.
- B. Clean, service, otherwise prepare items indicated for reuse
- C. Photographs or videotape, sufficiently detailed, of existing conditions of adjoining construction and site improvements that might be misconstrued as damage caused by selective demolition operations.
- D. Drain, purge, or otherwise remove, collect, and dispose of chemicals, gases, explosives, acids, flammables, or other dangerous materials before proceeding with selective demolition operations.

3.2 PROTECTION

- A. Locate, identify, and protect from damage, utilities that remain.
- B. Protect items to remain against damage and soiling during selective demolition.
- C. Protect bench marks, survey control points, and existing structures from damage or displacement.
- D. Use water mist and other suitable methods to limit the spread of dust and dirt. Comply with governing environmental protection regulations.

3.3 CLEARING

- A. Except for items or materials indicated to be reused, salvaged, reinstalled, or otherwise indicated to remain the Owner's property, demolished materials shall become the Contractor's property and shall be removed from the site with further disposition at the Contractor's option.
- B. Conduct demolition operations and remove debris to ensure minimum interference with roads, streets, walks, and other adjacent occupied and used facilities.
- C. Conduct demolition operations to prevent injury to people and damage to adjacent buildings, facilities, and site improvements to remain. Ensure safe passage of people around selective demolition area.

1. Provide temporary weather protection, during interval between demolition and removal of existing construction.
- D. Demolish and remove existing construction only to the extent required by new construction and as indicated.
- E. Clean adjacent structures and improvements of dust, dirt, and debris caused by selective demolition operations. Return adjacent areas to condition existing before start of selective demolition.
- F. Patch / repair holes, damaged surfaces caused to adjacent construction by selective demolition operations.
- G. Patch to produce surfaces that match existing surfaces suitable for new materials.

3.4 REMOVAL

- A. Storage or sale of removed items or materials on-site will not be permitted.
- B. Disposal: Promptly dispose of demolished materials. Do not allow demolished materials to accumulate on-site.
 1. Do not burn demolished materials.
 2. Transport demolished materials off Owner's property and legally dispose of them.
- C. Remove and transport debris in a manner that will prevent spillage on adjacent surfaces and areas.
- D. Remove asphaltic concrete paving, curbs/gutter, gravel, and concrete walks.
- E. When removing asphaltic concrete paving, curbs/gutters, and concrete walks. Neatly saw cut edges at right angles to surface.

END OF SECTION

SECTION 31-1100 SITE CLEARING

PART 1 GENERAL

1.1 MATERIAL OWNERSHIP

- A. Except for materials indicated to be stockpiled or to remain Owner's property, cleared materials shall become Contractor's property and shall be removed from the site.

1.2 TRAFFIC

- A. Do not close or obstruct streets, walks, or other adjacent occupied or used facilities without permission from Owner and authorities having jurisdiction.

1.3 REFERENCE TO SPECIFICATION

- A. Comply with governing city, state and federal regulations before starting site clearing. Comply with hauling and disposal regulations of authorities having jurisdiction.

PART 2 PRODUCTS

2.1 SATISFACTORY SOIL MATERIALS

- A. Requirements for satisfactory soil materials are specified in Division 31 Section "Earthwork".
 - 1. Obtain approved borrow soil materials off-site when satisfactory soil materials are not available on-site.

PART 3 EXECUTION

- A. Locate and clearly flag trees and vegetation to remain or to be relocated.
- B. Protect existing site improvements to remain from damage during construction.
 - 1. Restore damaged improvements to their original condition, as acceptable to Owner.
- C. Erect and maintain a temporary fence around drip line of individual trees or around perimeter drip line of groups of trees to remain. Remove fence when construction is complete.
 - 1. Where excavation for new construction is required within drip line of trees, hand clear and excavate to minimize damage to root systems. Use narrow-tine spading forks, comb soil to expose roots, and cleanly cut roots as close to excavation as possible.
- D. Do not excavate within drip line of trees, unless otherwise indicated.
- E. Remove trees marked for relocation using a tree spade. Relocate these trees to another location on-site to protect them during construction. Maintain these relocated trees during construction such that they remain healthy and able to be replanted in the final proposed location.
- F. Repair or replace trees and vegetation indicated to remain that are damaged by construction operations, in a manner approved by Architect.
- G. Utilities: Locate, identify, disconnect, and seal or cap off utilities as required. Do not interrupt utilities serving facilities occupied by Owner or others unless permitted. Arrange to provide temporary utility services.
 - 1. Excavate for and remove underground utilities indicated to be removed.
 - 2. Excavate around fiber optic line shall be completed by hand to ensure no disruption of service or damage to cable occurs. This shall be observed along the entire length of fiber optic cable. Once cable is excavated consult Civil Engineer and Electrical Engineer to review the cable location and condition. Install PVC protection over length of fiber optic cable per Electrical plans.
- H. Clearing and Grubbing: Remove obstructions, trees, shrubs, grass, and other vegetation to permit installation of new construction. Removal includes digging out stumps and obstructions and grubbing roots.
 - 1. Fill depressions with satisfactory soil material. Place fill material in horizontal layers not exceeding 8-inch loose depth, and compact each layer to a density equal to adjacent original ground.

2. Place warning devices advising pedestrians of clearing operation, and potential overhead dangers.
- I. Topsoil Stripping: Remove sod and grass before stripping topsoil. Strip topsoil to whatever depths are encountered in a manner to prevent intermingling with underlying subsoil or other waste materials.
 1. Stockpile topsoil materials away from edge of excavations without intermixing with subsoil. Grade and shape stockpiles to drain surface water.
- J. Site Improvements: Remove existing above- and below-grade improvements as indicated and as necessary to facilitate new construction.
- K. Disposal: Remove surplus soil material, unsuitable topsoil, obstructions, demolished materials, and waste materials, including trash and debris, and legally dispose of them off Owner's property.

END OF SECTION

SECTION 31-2200 EARTHWORK

PART 1 GENERAL

1.1 SCOPE OF WORK

- A. The Contractor shall obtain the National Pollution Discharge Elimination System (NPDES) General Storm Water Permit for Construction Activity requirements.
- B. The Contractor shall, unless specified otherwise, furnish all materials, equipment, tools and labor necessary to do the work required for mass grading of the project including, but not limited to stripping of topsoil, common excavation, filling and compacting as necessary for construction of building pad, pavements, walks, retaining walls and plazas.
- C. The CONTRACTOR shall also sheet, brace and support the adjoining ground or structures where necessary; provide adequate surface drainage; implement ground water management devices; provide barricades, guards and warning lights; install and maintain erosion control facilities; strip and salvage topsoil; reestablish turf with seed unless otherwise stipulated; remove waste material; and clean the site of all debris.

1.2 REFERENCE TO SPECIFICATION

- A. Comply with governing city, state and federal regulations before starting earthwork operations. Comply with hauling and disposal regulations of authorities having jurisdiction. Including but not limited to:
 - 1. National Pollution Discharge Elimination System (NPDES) General Storm Water Permit for Construction Activity requirements.
 - 2. American Society for Testing and Materials (ASTM) D 698 standard Proctor for laboratory compaction testing.
 - 3. ASTM D2488 "Description and Identification of Soils (Visual-Manual Procedure).
 - 4. ASTM D 2487- 93 Classification of Soils for Engineering Purposes (Unified Soil Classification System).
 - 5. Recommendations made by the Geotechnical Engineer in the Geotechnical Evaluation Report.
 - 6. Section 32-9123 – Structural Soil
- B. Definitions in this Section include the following:
 - 1. Backfill: Soil materials used to fill an excavation.
 - 2. Aggregate Base Course: Layer placed between the subgrade and asphalt paving.
 - 3. Borrow: Satisfactory soil imported from off-site for use as fill or backfill.
 - 4. Excavation: Removal of material encountered above subgrade elevations.
 - a. Unauthorized Excavation: Excavation below subgrade elevations or beyond indicated dimensions without direction by Engineer. Unauthorized excavation, as well as remedial work directed by Engineer shall be without additional compensation.
 - 5. Fill: Soil materials used to raise existing grades.
 - 6. Structural Soils: Soil materials that will be placed in the Tree Trenches.
 - 7. Structures: Buildings, footings, foundations, retaining walls, slabs, tanks, curbs, mechanical and electrical appurtenances, or other man-made stationary features constructed above or below the ground surface.
 - 7. Subgrade: Surface or elevation remaining after completing excavation, or top surface of a fill or backfill immediately below aggregate base, drainage fill, or topsoil materials.
 - 9. Tree Trenches: Landscaping islands where the parking lot trees will be located. These areas contain structural soils necessary to allow the trees to properly mature.
 - 10. Utilities include on-site underground pipes, conduits, ducts, and cables, as well as underground services within buildings.

- C. Existing Utilities: Do not interrupt utilities serving facilities occupied by Owner or others unless permitted in writing by Engineer and then only after arranging to provide temporary utility services according to requirements indicated.

The Contractor shall relocate and/or remove all existing utilities necessary to complete the work described in the plans. The Contractor to coordinate the removal and relocation of utilities with utility provider.

PART 2 PRODUCTS

2.1 MATERIALS

- A. Soil Materials: Provide borrow soil materials when sufficient satisfactory soil materials are not available from excavations. This borrow site material shall be approved by the Geotechnical Engineer, prior to use.
- B. Satisfactory Fill and Backfill Soils: On-site soils free of topsoil and pavement can be considered for reuse as backfill and fill. Imported material needed to replace excavation spoils or balance cut and fill quantities shall consist of sand having less than 20 percent of the particles by weight passing a #200 sieve.
- C. Unsatisfactory Soils: ASTM D 2487 soil classification groups GC, SC, ML, MH, CL, CH, OL, OH, and PT, or a combination of these group symbols.
- D. Backfill and Fill: Satisfactory soil materials as described in the Geotechnical Evaluation for the site.
- E. Infiltration Basin: Do not introduce planting material in the infiltration basin. The bottom of the basin should be the existing on-site soils.

PART 3 EXECUTION

3.1 PREPARATION

- A. Protect structures, utilities, sidewalks, pavements, and other facilities from damage caused by settlement, lateral movement, undermining, washout, and other hazards created by earthwork operations.
- B. Site Drainage and Erosion Control Measure:
 - 1. The CONTRACTOR shall be responsible for scheduling and conducting all of his various grading operations in a sequence that will insure that adequate drainage in all project areas is maintained at all times. Adequate drainage is interpreted as dispersal of existing or precipitated water as necessary to prevent interference with grading operations, delays or accumulations adversely affecting the soils.
 - 2. Erosion and sediment control measures by the CONTRACTOR shall be continuous or recurring as may be necessary on each drainage feature to insure adequate prevention of undesirable soil movement. This will entail the construction of temporary rock entrance pad, sedimentation basins and filter barriers that will pass water but strain out acceptable percentages of the sediment load. Diversion structures such as temporary compacted earth dikes, silt fences, sandbagging, side ditching and furrows shall be constructed where needed to intercept runoff before damaging concentrations can erode or pollute.
 - 3. Inlet protection or silt fence shall be placed around all catch basins during construction and maintained until turf is established.
 - 4. The silt fence shall be Geofab, Amoco Silt Stop, or approved equal. The spacing of the support posts shall be a maximum of five feet (5'). The fabric shall be anchored in a trench not smaller than six inches (6") wide. The trench shall be backfilled with compacted natural soil. The CONTRACTOR shall replace any unapproved filtration fabric. The CONTRACTOR shall correct any erosion or sedimentation damage created outside the construction limits of the project, if directly caused by the CONTRACTOR'S operation, with no additional compensation.
- C. Topsoil Stripping: Remove sod and grass before stripping topsoil. Strip topsoil to whatever depths are encountered in a manner to prevent intermingling with underlying subsoil or other waste materials.
 - 1. CONTRACTOR shall strip surficial topsoil from below the building slab areas, along with any existing fill or concrete material within one (1) foot below the slab. The ground surface shall be compacted by a minimum of four (4) passes of a large, self propelled, vibratory, compactor.

2. Stockpile enough topsoil materials in designated areas approved by the Engineer and away from edge of excavations without intermixing with subsoil to allow a minimum of six (6) inches to be respread over proposed lawn areas. Grade and shape stockpiles to drain surface water. Place excess or unsuitable materials in perimeter Berm areas.
- D. Excavate to subgrade elevations regardless of the character of surface and subsurface conditions encountered, soil materials, and obstructions.
1. If excavated materials intended for fill and backfill include unsatisfactory soil materials replace with satisfactory soil materials.
 2. All excavation and embankment areas involved in or disturbed by the grading construction shall be finished in reasonably close conformity with the plans. It shall be the CONTRACTOR'S responsibility to grade the project to conform to the plan elevations.
 3. Any area higher or lower than 0.10 feet of plan elevation shall be re-graded by the CONTRACTOR at his expense unless in the opinion of the Engineer, the variance is not harmful and the quantity balance is not excessively disturbed. If such regrading is necessary, the topsoil will be resalvaged and respread at the CONTRACTOR'S expense.
 4. All building pads and streets shall be graded to within 0.1 foot of the grade required under this Contract, that grade being the finished grade less the specified hold down. The 0.1 foot tolerance shall not be consistently high or low leaving the project with an unbalanced excess or shortage of material for final construction.
 5. CONTRACTOR to remove and discard off-site all concrete material resulting from all excavations on the site.
 6. CONTRACTOR to excavate utility trenches a minimum of six (6) inches below pipes.
- E. Infiltration Basin and Tree Trench Excavation: Excavate to subgrade elevations regardless of the character of surface and subsurface conditions encountered, soil materials, and obstructions. Protect exposed infiltration areas to avoid compaction of infiltration area soils.
1. Utilize appropriate equipment to excavate to proposed bottom grade of the infiltration areas in such a manner so as not to compact the existing soils that will remain in place.
 2. Once excavation is complete perform a double-ring infiltrometer tests per ASTM D3385 in the bottom of each infiltration area. Consult Engineer with test results to allow verification of infiltration system design.
- E. Proof roll subgrades, before filling or placing aggregate courses, with heavy pneumatic-tired equipment to identify soft pockets and areas of excess yielding. Do not proof roll wet or saturated subgrades. Do not proof roll infiltration areas.
- F. Reconstruct subgrades damaged by freezing temperatures, frost, rain, accumulated water, or construction activities.
- G. Fill: Place and compact fill material in layers to required elevations. Before placing embankment on an existing slope steeper than 4 horizontal to 1 vertical (4:1), the CONTRACTOR shall, at his option: flatten the existing slope to the extent that it will not be steeper than 4 to 1; or construct steps in the slope, with the back surface being as nearly vertical as practical and with the horizontal cuts being made as close together as the slope permits, but with no step being less than one foot in width.
1. Where structural embankment is to be constructed, the unsuitable materials shall be excavated to remove organic and unstable material as directed by the Geotechnical Engineer. Prior to placing embankment materials, water shall be removed from the excavated areas by pumping or by means of drainage ditches.
 2. Embankments shall not be constructed during periods when the embankment material freezes while being placed and compacted, nor shall any embankment material be placed on soil that is frozen. Where the foundation soil is frozen, at a time when weather conditions are such that embankment construction could be continued without the material freezing as it is being placed and compacted, the CONTRACTOR may be permitted to excavate the frozen foundation soil and proceed with the embankment construction for so long as the weather will permit, but only if and to the extent approved by the Soils Engineer. The frozen soil shall be pulverized or wasted and replaced with other suitable soil, as may be necessary to construct the embankments as specified.

3. Fill in building slab areas shall be clean sands or gravels having less than 10% particles passing a number 200 sieve. Crushed limestone is not a suitable fill material for building slab areas.
 4. CONTRACTOR may use clay material excavated from footing trenches as exterior foundation backfill. Clean sands or gravel having less than 10% particles passing a number 200 sieve shall be used as fill on the interior side of the foundation wall.
 5. CONTRACTOR shall fill utility trenches with no less than six (6) inches of clean sands or gravels having less than 10% particles passing a number 200 sieve. Clean sands or gravels shall be placed to a minimum of ½ diameter of the pipe in all utility trenches. Fill materials above utility pipes shall be lean clays similar to clay material on-site.
 6. CONTRACTOR shall fill tree trenches consistent with specification Section 32-9123 – Structural Soil and design details.
- H. Uniformly moisten or aerate subgrade and each subsequent fill or backfill layer before compaction to within 2 percent of optimum moisture content.
1. Remove and replace, or scarify and air-dry, otherwise satisfactory soil material that exceeds optimum moisture content by 2 percent and is too wet to compact to specified dry unit weight.
- I. Compaction: Place backfill and fill materials in layers not more than 8 inches in loose depth for material compacted by heavy compaction equipment, and not more than 6 inches in loose depth for material compacted by hand-operated tampers.
1. Compaction shall be to the following specifications:

Location	Relative Compaction, percent (ASTM D698 – Standard Proctor)	Moisture Content Variance from Optimum, percentage points
Within Building Pad	98	-3 to +3
Below pavements, within 3 feet of subgrade elevations	100	-1 to +1
Below pavements, more than 3 feet below subgrade elevations	95	-3 to +3
Below landscaped surfaces	90	+-5

2. CONTRACTOR to compact soils in footing trenches with four (4) passes of a self-propelled or tow-behind vibratory compactor.
 3. Fill material above utility pipes shall be compacted to no less than 100% of its maximum standard Proctor density to a maximum depth of (3) feet below top of subgrade.
- J. Hold Downs: The elevations shown on the plans are finished elevations of the constructed floor slabs, street pavements and/or topsoil. To account for the additional pavement, slab thickness, granular cushions, or topsoil the plans also indicate the appropriate hold-downs. The hold down is defined as the difference in feet or inches between the finished elevation and interim elevation established during site grading. Where needed to provide drainage from areas depressed by the hold down, the CONTRACTOR shall construct drainage channels, sumps or temporary culverts to maintain a dry subgrade.
- K. Dust Control: The CONTRACTOR shall maintain dust control as necessary and in a manner satisfactory to the Engineer, City and Watershed, until the project has been completed.
- L. Testing Agency: Contractor will engage a qualified independent geotechnical engineering testing agency to perform field quality-control testing.
1. Allow testing agency to inspect and test subgrades and each fill or backfill layer. Proceed with subsequent earthwork only after test results for previously completed work comply with requirements.

2. When testing agency reports that subgrades, fills, or backfills have not achieved degree of compaction specified, scarify and moisten or aerate, or remove and replace soil to depth required; recompact and retest until specified compaction is obtained.
 3. Subgrade soils shall be approved by qualified geotechnical engineer after stripping of the topsoil and digging the footing trenches. Geotechnical engineer shall be present to observe and evaluate the surface compaction operation.
 4. Compaction tests shall be performed on fill material placed below building slab areas.
- M. Repair and reestablish grades to specified tolerances where completed or partially completed surfaces become eroded, rutted, settled, or where they lose compaction.
- N. Where settling occurs before Project correction period elapses, remove finished surfacing, backfill with additional soil material, compact, and reconstruct surfacing.
- O. Disposal: Remove, trash, and debris, and legally dispose of it off Owner's property on a daily basis.

3.2 SUBMITTALS

- A. A Water Control Plan shall be submitted for review, no less than 10 days before the scheduled date for the start of earthwork operations. The plan shall indicate the methods and techniques to be used for control of water (both surface water and groundwater) during construction.

END OF SECTION

SECTION 31-2219 FINISH GRADING

PART 1 GENERAL

1.1 SECTION INCLUDES

- A. Final grading of topsoil for finish landscaping.

1.2 REFERENCE TO SPECIFICATION

- A. Section 31-2200 - Earthwork.

1.3 SUBMITTALS

- A. 10 pound Samples of each type of fill to testing laboratory, in air-tight containers.
- B. Name supplier, and source of imported materials.

1.4 QUALITY ASSURANCE

- A. Provide all imported materials from the same source.
- B. Comply with governing city, state and federal regulations before starting finish grading. Comply with hauling and disposal regulations of authorities having jurisdiction.
- C. Comply with geotechnical report recommendations.

PART 2 PRODUCTS

2.1 MATERIALS

- A. Topsoil: Excavated and reused material conforming to ASTM D2487 Group Symbol OH and PT, graded, reasonably free of roots, rocks larger than 1/2 inch, subsoil, debris, large weeds, and foreign matter.
- B. Topsoil: Imported friable loam, conforming to ASTM D2487 Group Symbol OH and PT; reasonably free of roots, rocks larger than 1/2 inch, subsoil, debris, large weeds, and foreign matter. Acidity range of pH 5.5 to 7.5; containing between 4 percent and 25 percent inorganic matter.

2.2 SOURCE QUALITY CONTROL

- A. Tests and analysis, subsoil material: Comply with Geotechnical Engineer.
- B. Tests and analysis, topsoil material: Comply with Geotechnical Engineer.
- C. Change of material or source: If tests indicate materials do not comply with the Contract Documents, change material and retest at no additional cost to the Owner.

PART 3 EXECUTION

3.1 SUBSTRATE PREPARATION

- A. Eliminate uneven areas and low spots.
- B. Remove debris, roots, branches, and stones in excess of 1/2 inch in size.
- C. Scarify subgrade to depth of 3 inches where topsoil is scheduled. Scarify in areas where equipment is used for hauling and spreading topsoil and has compacted subsoil.

3.2 PLACING TOPSOIL

- A. Place topsoil in areas where turf seeding, sodding and planting are scheduled; to a nominal depths described in Section 3.4. Place topsoil during dry weather.
- B. Do not place topsoil infiltration areas.
- C. Fine grade topsoil eliminating rough or low areas. Maintain profiles and contour of subgrade.
- D. Remove roots, weeds, rocks, and foreign material while spreading.
- D. Manually spread topsoil close to trees, plants and building to prevent damage.
- F. Lightly compact placed topsoil.

- G. Remove surplus subsoil and topsoil from site.
- H. Leave stockpile area and site clean, raked, and ready to receive landscaping.

3.3 TOLERANCES

- A. Top of topsoil: Plus or minus 1/2 inch.

3.4 SCHEDULE

- A. Compacted topsoil thickness:
 - 1. Seeded turf grass: 4 inches.
 - 2. Seeded native grasses: 4 inches. No additional topsoil should be added in the infiltration areas.
 - 2. Sod: 4 inches.
 - 3. Shrub beds: 12 inches.
 - 4. Perennial beds: 12 inches.

END OF SECTION

SECTION 31-2300 EXCAVATION AND FILL

PART 1 GENERAL

1.1 SECTION INCLUDES

- A. Excavation, filling, grading and compacting.
- B. Trenching and backfill for mechanical and electrical work and utilities.
- C. Subbase materials, drainage fill, and common fill materials for slabs, pavements, and improvements.
- D. Foundation drain tile.
- E. Erosion Control

1.2 1.02 RELATED WORK

- A. Section 31-2219 – Finish Grading.
- B. Section 01-5713 – Temporary Erosion and Sedimentation Control

PART 2 PRODUCTS

2.1 MATERIALS

- A. Subbase material: Gravel or crushed stone graded for intended use as subbase for paving materials specified.
- B. Drainage fill: Washed gravel or crushed stone, 1/4 inch to 3/4 inch size; ASTM C33, Size 67.
- C. Fill and Backfill: On-site soils free of topsoil and pavement can be considered for reuse as backfill and fill. Imported material needed to replace excavation spoils or balance cut and fill quantities shall consist of sand having less than 20 percent of the particles by weight passing a #200 sieve.
- D. Drain tile: Rigid PVC, 6-inches diameter, SDR41, perforated on bottom, bell joints; provide cleanout at each building corner.

PART 3 EXECUTION

3.1 EROSION CONTROL

- A. Protect structures, utilities, sidewalks, pavements, and other facilities from damage caused by settlement, lateral movement, undermining, washout, and other hazards created by earthwork operations.
- B. Site Drainage and Erosion Control Measure
 - 1. Schedule and conduct all grading operations in a sequence that will insure adequate drainage in all project areas at all times. Adequate drainage is the dispersal of existing or precipitated water as necessary to prevent interference with grading operations, delays or accumulations adversely affecting the soils.
 - 2. Erosion and sediment control measures shall be continuous or recurring as necessary to ensure adequate protection of undesirable soil movement. These measures include:
 - a. Silt fence placement in accordance with the SWPPP.
 - b. Temporary rock entrance pads in accordance with the SWPPP.

3.2 INSTALLATION

- A. Excavation is unclassified and includes excavation to subgrade regardless of materials encountered. Repair excavations beyond elevations and dimensions indicated as follows:
 - 1. At structure: Concrete or structural fill.
 - 2. Elsewhere: Backfill and compact.
- B. Do not perform additional work if subgrade material is unsuitable for intended use.
- C. Prevent water from accumulating in excavations.

- D. Stockpile satisfactory materials for reuse. Provide proper drainage and do not stockpile materials within drip line of trees to remain.
- E. Compact materials at the optimum moisture content as determined by ASTM D1557 by aeration or wetting to the following percentages of maximum dry density:
 - 1. Structure, pavement, walkways: Subgrade and each fill layer to 95 percent of maximum dry density.
 - 2. Unpaved areas: Top 6 inches of subgrade and each fill layer to 90 percent maximum dry density.
- F. Place acceptable materials in layers not more than 8 inches loose depth for materials compacted by heavy equipment and not more than 4 inches loose depth for materials compacted by hand equipment.
 - 1. Structural fill: Under foundations and slabs on grade.
 - 2. Drainage fill: Under building slabs, at foundation drainage, elsewhere as indicated.
 - 3. Common fill: Under unpaved areas.
 - 4. Subbase material: Under pavement, walks, steps, piping, conduit.
- G. Grade to within 1/2 inch above or below required subgrade, within 1/2 inch in 10 feet.
- H. Protect newly graded areas from traffic and erosion. Recompact and regrade settled, disturbed, or damaged areas as necessary to restore quality, appearance, and condition of work.
- I. Control erosion and windblown dust. Legally dispose of waste and unsuitable materials off site.

END OF SECTION

SECTION 31-5000 EXCAVATION SUPPORT AND PROTECTION

PART 1 GENERAL

- A. Comply with governing city, state and federal regulations before starting excavation support and protection. Comply with hauling and disposal regulations of authorities having jurisdiction.
- B. Performance Requirements: Design, provide, monitor, and maintain an anchored and braced excavation support and protection system capable of resisting soil and hydrostatic pressure and supporting sidewalls of excavations.
 - 1. System design and calculations must be acceptable to authorities having jurisdiction.
- C. Existing Utilities: Do not interrupt utilities serving facilities occupied by the Owner or others unless permitted in writing by the Architect and then only after arranging to provide temporary utility services according to requirements indicated. The Contractor shall relocate and/or remove all existing utilities necessary to complete the work described in the plans. The Contractor to coordinate the removal and relocation of utilities with utility provider.
- D. Project Site Information: A geotechnical report has been prepared for this Project and is available for information only. The report is not part of the Contract Documents. Owner will not be responsible for interpretations or conclusions drawn from this data by Contractor.
 - 1. Make additional test borings and conduct other exploratory operations as necessary.

PART 2 PRODUCTS

- A. Not Applicable.

PART 3 EXECUTION

- A. Protect structures, utilities, sidewalks, pavements, and other facilities from damage caused by settlement, lateral movement, undermining, washout, and other hazards that could develop during excavation support and protection system operations.
- B. Install excavation support and protection systems to ensure minimum interference with roads, streets, walks, and other adjacent occupied and used facilities.
- C. Locate excavation support and protection systems clear of permanent construction and to permit forming and finishing of concrete surfaces.
- D. Monitor excavation support and protection systems daily during excavation progress and for as long as excavation remains open. Promptly correct bulges, breakage, or other evidence of movement to ensure excavation support and protection systems remain stable.
- E. Promptly repair damages to adjacent facilities caused by installing excavation support and protection systems.
- F. Remove excavation support and protection systems when construction has progressed sufficiently to support excavation and bear soil and hydrostatic pressures. Remove in stages to avoid disturbing underlying soils and damaging structures, pavements, facilities, and utilities.
 - 1. Remove excavation support and protection systems to a minimum depth of 48 inches below overlying construction and abandon remainder.

END OF SECTION

SECTION 32-1216 ASPHALT PAVING

PART 1 GENERAL

1.1 SECTION INCLUDES

- A. Hot-mixed asphalt paving over prepared subbase.
- B. Proof rolling of prepared subbase.
- C. Painting and striping on bituminous pavement.

1.2 RELATED WORK

- A. Section 31-2200 - Earthwork.

1.3 SUBMITTALS

- A. Material Certificates signed by material producer and Contractor, certifying that each material item complies with Specifications.

1.4 SITE CONDITIONS

- A. Apply prime and tack coats when ambient temperature is above 50 degrees F and when temperature has not been below 35 degrees F for 12 hours immediately prior to application. Do not apply when base is wet or contains an excess of moisture.
- B. Construct hot-mixed asphalt surface course when atmospheric temperature is above 40 degrees F and when base is dry. Base course may be placed when air temperature is above 30 degrees F and rising.

PART 2 PRODUCTS

2.1 MATERIALS

- A. General: Use locally available materials and gradations that exhibit a satisfactory record of previous installations.
- B. Coarse aggregate: Sound, angular crushed stone or crushed gravel, complying with ASTM D692.
- C. Fine aggregate: Sharp-edged natural sand or sand prepared from stone, gravel, or combinations thereof, complying with ASTM D1073.
- D. Mineral filler: Rock, hydraulic cement, or other inert material complying with ASTM D242.
- E. Asphalt cement: ASTM D3381 for viscosity-graded material; ASTM D946 for penetration-graded material.
- F. Tack coat: Emulsified asphalt; ASTM D977.
- G. Lane marking paint: Acrylic, colors as selected. Sherwin-Williams Hotline Waterborne, BP1400 Series, or approved equal.

2.2 ASPHALT-AGGREGATE MIXTURE

- A. Provide plant-mixed, hot-laid asphalt-aggregate mixture complying with ASTM D3515 and as recommended by local paving authorities to suit project conditions.

PART 3 EXECUTION

3.1 SURFACE PREPARATION

- A. Remove loose material from compacted subbase surface immediately before proof rolling.
- B. Proof-roll prepared subbase surface to check for unstable areas and areas requiring additional compaction.
- C. Do not begin paving work until deficient subbase areas have been corrected and are ready to receive paving.
- D. Apply tack coat to contact surfaces of previously constructed asphalt or portland cement concrete and surfaces abutting or projecting into hot-mixed asphalt pavement. Distribute at rate of 0.05 to 0.15 gallons per square yard of surface.

- E. Allow to dry until at proper condition to receive paving.
- F. Exercise care in applying bituminous materials to avoid smearing of adjoining concrete surfaces. Remove and clean damaged surfaces.

3.2 PLACING MIX

- A. Place hot-mixed asphalt mixture on prepared surface; spread and strike off. Spread mixture at minimum temperature of 225 degrees F. Place by hand areas inaccessible to equipment. Place each course to required grade, cross-section, and compacted thickness.
- B. Place pavement in strips not less than 10 feet wide, unless otherwise acceptable to Engineer. After first strip has been placed and rolled, place succeeding strips and extend rolling to overlap previous strips. Complete base course for a section before placing surface course.
- C. Immediately correct surface irregularities in finish course behind paver. Remove with shovel or lute excess material forming high spots.
- D. Saw cut joints between old and new pavements, or between successive days' work, to ensure continuous bond between adjoining work. Construct joints to have same texture, density, and smoothness as other sections of hot-mixed asphalt course. Clean contact surfaces and apply tack coat.

3.3 ROLLING

- A. Begin rolling when mixture will bear roller weight without excessive displacement.
- B. Compact mixture with hot hand tampers or vibrating plate compactors in areas inaccessible to rollers.
- C. Accomplish breakdown or initial rolling immediately following rolling of joints and outside edge. Check surface after breakdown rolling, and repair displaced areas by loosening and filling, if required, with hot material.
- D. Complete second rolling as soon as possible after breakdown rolling while mixture is still hot. Continue second rolling until mixture has been evenly compacted.
- E. Perform finish rolling while mixture is still warm enough for removal of roller marks. Continue rolling until roller marks are eliminated and course has attained 95 percent laboratory density.
- F. Remove and replace defective areas and paving areas mixed with foreign materials. Cut out such areas and fill with fresh, hot-mixed asphalt. Compact by rolling to specified surface density and smoothness.
- G. After final rolling, erect barricades, and prohibit vehicular traffic on pavement until it has cooled and hardened.

3.4 TRAFFIC AND LANE MARKINGS

- A. Sweep and clean surface to eliminate loose material and dust.
- B. Do not apply traffic and lane marking paint until layout and placement have been verified with Engineer.
- C. Apply paint with mechanical equipment to produce uniform straight edges.

3.5 FIELD QUALITY CONTROL

- A. General: Test in-place hot-mixed asphalt courses for compliance with requirements for thickness and surface smoothness. Repair or remove and replace unacceptable paving as directed by Engineer.
- B. Thickness: In-place compacted thickness tested in accordance with ASTM D3549 will not be acceptable if it exceeds following allowable variations:
 - 1. Base course: Plus or minus 1/8 inch.
 - 2. Surface course: Plus or minus 1/8 inch.
- C. Surface smoothness: Test finished surface of each hot-mixed asphalt course for smoothness using 10 feet straightedge applied parallel with and at right angles to centerline of paved area. Surfaces will not be acceptable if exceeding the following tolerances for smoothness:
 - 1. Base course surface: 1/8 inch.

2. Wearing course surface: 1/8 inch.
 3. Crowned surfaces: Test with crowned template centered and at right angle to crown. Maximum allowable variance from template is 1/4 inch.
- D. Check surface areas at intervals as directed.

END OF SECTION

SECTION 32-1313 CEMENT CONCRETE PAVING

PART 1 GENERAL

- A. Comply with governing city, state and federal regulations before starting paving operations. Comply with hauling and disposal regulations of authorities having jurisdiction.
- B. Submittals: In addition to Product Data, submit design mixes for each concrete pavement mix.
 - 1. Submit material certificates signed by manufacturers certifying that each concrete material complies with requirements.
- C. Quality Assurance: Comply with ACI 301, "Specification for Structural Concrete," unless modified by the requirements of the Contract Documents.
 - 1. Installer Qualifications: An experienced installer who has completed pavement work similar in material, design, and extent to that indicated for this Project and whose work has resulted in construction with a record of successful in-service performance.
 - 2. Manufacturer Qualifications: Manufacturer of ready-mixed concrete products complying with ASTM C 94 requirements for production facilities and equipment.

PART 2 PRODUCTS

- A. Form Materials: Plywood, metal, metal-framed plywood, or other approved panel-type materials to provide full-depth, continuous, straight, smooth exposed surfaces.
- B. Reinforcement: All concrete slabs and pavement shall conform to the guidelines and recommendations of the American Concrete Institute for reinforcement of cast-in-place concrete slabs.
- C. Steel Reinforcement Materials: As follows:
 - 1. Plain-Steel Welded Wire Fabric: ASTM A 185, flat sheets.
 - 2. Reinforcement Bars: ASTM A 615/A 615M, Grade 60 (Grade 420), deformed.
 - 3. Plain Steel Wire: ASTM A 82.
 - 4. Supports: Bolsters, chairs, spacers, and other devices for spacing, supporting, and fastening steel reinforcement; manufactured according to CRSI's "Manual of Standard Practice"
- D. Concrete Materials: As follows:
 - 1. Portland Cement: ASTM C 150, Type I or II.
 - a. Fly Ash: ASTM C 618, Class F or C.
 - b. Ground Granulated Blast-Furnace Slag: ASTM C 989, Grade 100 or 120.
 - 2. Aggregate: ASTM C 33, uniformly graded, from a single source.
 - 3. Water: ASTM C 94.
 - 4. Synthetic Fiber: Fibrillated or monofilament polypropylene fibers engineered and designed for use in concrete pavement, complying with ASTM C 1116, Type III, 1/2 to 1 inch long.
- E. Admixtures certified by manufacturer to contain not more than 0.1 percent water-soluble chloride ions by mass of cement and to be compatible with other admixtures, as follows:
 - 1. Air-Entraining Admixture: ASTM C 260.
 - 2. Water-Reducing Admixture: ASTM C 494, Type A.
 - 3. High-Range, Water-Reducing Admixture: ASTM C 494, Type F.
 - 4. Water-Reducing and Accelerating Admixture: ASTM C 494, Type E.
 - 5. Water-Reducing and Retarding Admixture: ASTM C 494, Type D.
- F. Curing Materials: As follows:
 - 1. Absorptive Cover: AASHTO M 182, Class 2, burlap cloth made from jute or kenaf, weighing approximately 9 oz./sq. yd. dry.
 - 2. Moisture-Retaining Cover: ASTM C 171, polyethylene film or white burlap-polyethylene sheet.
 - 3. Water: Potable.
 - 4. Evaporation Retarder: Waterborne, monomolecular film forming, manufactured for application to fresh concrete.
 - 5. Clear Solvent-Borne Liquid-Membrane-Forming Curing Compound: ASTM C 309, Type 1, Class B.

6. Clear Waterborne Membrane-Forming Curing Compound: ASTM C 309, Type 1, Class B.
 7. White Waterborne Membrane-Forming Curing Compound: ASTM C 309, Type 2, Class B.
- G. Related Materials: As follows:
1. Expansion- and Isolation-Joint-Filler Strips: ASTM D 1751, asphalt-saturated cellulosic fiber, or ASTM D 1752, cork or self-expanding cork.
- H. Concrete Mixes: Prepare design mixes, proportioned according to ACI 211.1, ACI 301, and ACI 318, with the following properties:
1. Compressive Strength (28 Days): 4500 psi.
 2. Maximum Water-Cementitious Materials Ratio: 0.45.
 3. Slump Limit: 4 inches.
 4. Air Content: 4.5 to 7.5 percent.
- I. Synthetic Fiber: Uniformly disperse in concrete mix at manufacturer's recommended rate, but not less than 1.0 lb/cu. yd.
- J. Coloring Agent: Add coloring agent to mix according to manufacturer's written instructions.
- K. Ready-Mixed Concrete: Comply with requirements and with ASTM C 94.
- L. Ready-Mixed Concrete: Comply with requirements and with ASTM C 94 and ASTM C 1116.
- M. Project-Site Mixing: Comply with requirements and measure, batch, and mix concrete materials and concrete according to ASTM C 94. Mix concrete materials in appropriate drum-type batch machine mixer.

PART 3 EXECUTION

- A. Surface Preparation: Proof-roll prepared subbase, and remove loose material from surface.
- B. Forms: Set, brace, and secure edge forms, bulkheads, and intermediate screed guides for pavement to required lines, grades, and elevations.
- C. Reinforcement: Accurately position and support reinforcement, and secure against displacement. Set wire ties with ends directed into concrete.
1. Install welded wire fabric in lengths as long as practicable; lap at least one full mesh, and lace splices with wire.
- D. Joints: Locate and install construction, isolation, contraction, and expansion joints as indicated.
- E. Concrete Placement: Comply with recommendations in ACI 304R for measuring, mixing, transporting, and placing concrete. Place concrete in a continuous operation within planned joints or sections.
1. Moisten subbase to provide a uniform dampened condition at time concrete is placed.
 2. Consolidate concrete by mechanical vibrating equipment supplemented by hand-spading, rodding, or tamping according to recommendations in ACI 309R.
 3. Screed and initial-float concrete surfaces with darby or bull float before excess moisture or bleed water appears on the surface.
 4. Protect concrete from cold or hot weather during mixing, placing, and curing.
- F. Evaporation Retarder: Apply to concrete surfaces if hot, dry, or windy conditions cause moisture loss approaching 0.2 lb/sq. ft. x h before and during finishing operations. Apply according to manufacturer's written instructions after placing, screeding, and bull floating or darbying concrete, but before float finishing.
- G. Float Finish: Begin the second floating operation when bleed-water sheen has disappeared and the concrete surface has stiffened sufficiently to permit operations. Float surfaces to true planes with gaps below 10-foot-long, unlevelled straightedge not to exceed 1/4 inch. Cut down high spots, and fill low spots. Rfloat surface immediately to uniform granular texture.
1. Burlap Finish: Drag a seamless strip of damp burlap across float-finished concrete, perpendicular to line of traffic, to provide a uniform, gritty texture.
 2. Medium-to-Fine-Textured Broom Finish: Draw a soft bristle broom across float-finished concrete surface, perpendicular to line of traffic, to provide a uniform, fine-line texture.

3. Medium-to-Coarse-Textured Broom Finish: Provide a coarse finish by striating float-finished concrete surface 1/16 to 1/8 inch deep with a stiff-bristled broom, perpendicular to line of traffic.
- H. Curing: Begin curing after finishing concrete, but not before free water has disappeared from concrete surface. Cure concrete by one or a combination of the following methods:
 1. Moisture cure concrete by water, continuous fog spray, continuously wet absorptive cover, or by moisture-retaining-cover curing. Keep surfaces continuously moist for not less than seven days.
 2. Curing Compound: Apply uniformly in continuous operation by power spray or roller according to manufacturer's written instructions. Recoat areas subjected to heavy rainfall within three hours after initial application. Maintain continuity of coating and repair damage during curing period.
 - I. Remove and replace concrete pavement that is broken, damaged, or defective, or does not meet requirements in this Section.
 - J. Protect concrete from damage. Exclude traffic from pavement for at least 14 days after placement.
 - K. Maintain concrete pavement free of stains, discoloration, dirt, and other foreign material. Sweep concrete pavement not more than two days before date scheduled for Substantial Completion inspections.

END OF SECTION

SECTION 32-8400 IRRIGATION

PART 1 GENERAL

1.1 SECTION INCLUDES

- A. Pipe and fittings, valves, sprinkler heads, emitters, bubblers, and accessories.
- B. Control system.

1.2 RELATED WORK

- A. Mechanical: Water supply.
- B. Electrical: Conduit, wire, cable, and power supply connections.

1.3 SYSTEM DESCRIPTION

- A. Electric solenoid controlled underground irrigation system, with pressure blow-out drain.
- B. Source power: 120-volt, 15 A., single phase.
- C. Low voltage controls: 24-volt, 2 A.
- D. The water supply will be from a municipal water source. Verify water supply and pressure prior to submitting shop drawings.
- E. System must provide separation of all turf from planting areas via different zoning of heads. Turf and planting areas must be able to be controlled separately due to the varied water use of planting types.

1.4 SUBMITTALS

- A. Manufacturer's Product Data, including instructions for operation and maintenance of system and controls, seasonal activation and shutdown, and manufacturer's parts catalog.
- B. Shop Drawings showing pipe layout to water source, location of sleeves under pavement, location and coverage of sprinkler heads, plant and landscaping features, site structures, schedule of fittings to be used. Include component and control system wiring diagrams.
- C. Samples of each component. Accepted samples may be used in the Work.
- D. Record actual locations of concealed components, piping system, and conduit.
- E. Schedule indicating length of time each valve is required to be open to provide a determined amount of water.

1.5 QUALITY ASSURANCE

- A. Manufacturer: Company specializing in manufacturing the products specified in this Section with minimum 3 years' experience.
- B. Installer: Company specializing in performing work of this Section with 3 years experience.
- C. Products requiring electrical connection will be listed and classified by UL as suitable for indicated conditions of use.

1.6 REGULATORY REQUIREMENTS

- A. Conform to State plumbing code for piping and component requirements.

1.7 PRE-INSTALLATION MEETING

- A. Convene 7 days before beginning irrigation work at site.

1.8 MAINTENANCE STOCK

- A. Furnish the following maintenance materials identical to those installed. Deliver to the site and store where directed.
 - 1. 2 sprinkler heads of each type and size.
 - 2. 2 valve keys for manual valves.
 - 3. 2 valve box keys.
 - 4. 2 keys for valve markers.
 - 5. 2 wrenches for each type head core and for removing and installing each type head.

PART 2 PRODUCTS

2.1 PIPE

- A. Acceptable manufacturers
 - 1. Harvel.
 - 2. Bryant Plastics.
 - 3. Bristol Pipe, Inc.
 - 4. Accepted Equals
- B. Pipe: PVC, ASTM 2241; 200 psi upstream from controls, 160 psi downstream.
- C. Pipe: ABS, ANSI/ASTM D2282; 160 psi upstream from controls, 100 psi downstream.
- D. Pipe: Copper, ASTM B42 Regular.
- E. Joints: solvent welded sockets for all pipe less than 4" diameter. Rubber gasketed joints for all pipe 4" diameter or greater.
- F. Solvent cement: ANSI/ASTM D2564 for PVC pipe and fittings and/or ASTM D2235 for ABS pipe and fittings.
- G. Solder and flux: ASTM B32 Type 95TA solder; paste flux.
- H. Sleeves: PVC at least 2" larger in diameter than pipe being sleeved.

2.2 OUTLETS

- A. Acceptable manufacturers
 - 1. Toro
 - 2. Rainbird
 - 3. Hunter
- B. Primary material: Brass or plastic.
- C. Rotary sprinkler head: Pop-up with screens; fully adjustable for flow and pressure; integral letter or symbol designating degree of arc and arrow indicating center of spray pattern.
- D. Spray sprinkler head: Pop-up heads with replaceable and/or adjustable spray patterns
- E. Emitter: Adjustable outlet, non-clogging, trickle tubes.
- F. Bubbler: Adjustable outlet and precipitation rates.
- G. Quick coupler: 3/4" Brass. One per zone

2.3 VALVES

- A. Acceptable manufacturers
 - 1. Irritrol
 - 2. Nelson
 - 3. Hunter
 - 4. Approved Equal
- B. Construction: Gate or ball valves, bronze construction non-rising stem.
- C. Backflow preventers: Bronze body, reduced pressure zone.
- D. Valve box and cover: Plastic. Sized to comfortably access all system components
- E. Drain valve.

2.4 CONTROLS

- A. Acceptable manufacturers
 - 1. Toro
 - 2. Rainbird
 - 3. Hunter
 - 4. Approved Equal.
- B. **WaterSense labeled weather-based irrigation controller:** Automatic controller, microprocessor solid state control with visible readout display, rain sensor and temporary override feature to bypass cycle for inclement weather, timer for a multi-station system, programmable for 7 days in quarter hour increments, with automatic start and shutdown.
- C. Controller housing: NEMA 250 Type 4; weatherproof, watertight, lockable access door.
- D. Valves: Electric solenoid; normally closed; wiring, including required fittings and accessories.
- E. Wire conductors: Color coded.

PART 3 EXECUTION

3.1 PREPARATION

- A. Piping layout indicated is diagrammatic. Route piping to avoid plants, ground cover, and structures.
- B. Layout and stake locations of system components.
- C. Review layout requirements with other affected work. Coordinate locations of sleeves to accommodate system.

3.2 TRENCHING

- A. Trench and backfill as specified in Section 31-2300.
- B. Trench size:
 - 1. Minimum width: 6 inches.
 - 2. Minimum cover over installed supply piping: 20 inches.
 - 3. Minimum cover over installed branch piping: 12 inches.
 - 4. Minimum cover over installed outlet piping: 12 inches.

- C. Trench to accommodate grade changes. Slope to drains.
- D. Maintain trenches free of debris, material, or obstructions that may damage pipe.

3.3 INSTALLATION

- A. Connect to utilities.
- B. Set outlets and box covers at finish grade elevations.
- C. Provide for thermal movement of components in system.
- D. Slope piping for self drainage to drainage pit.
- E. Use threaded nipples for risers to each outlet.
- F. Provide 10 inches expansion coil at each valve to which controls are connected, and at 100-foot intervals. Bury wire beside pipe. Mark valves with neoprene valve markers containing locking device. Set valve markers in 160 psi PVC pipe risers exiting from top of valve to finish grade.
- G. After piping is installed, but before outlets are installed and backfilling commences, open valves and flush system with full head of water.

3.4 FIELD QUALITY CONTROL

- A. Prior to backfilling, test system for leakage for whole system to maintain 100 psi pressure for 1 hour.
- B. System is acceptable if no leakage or loss of pressure occurs during test period.

3.5 ADJUSTING

- A. Adjust control system to achieve time cycles required.
- B. Adjust head types for full water coverage as directed.

3.6 DEMONSTRATION

- A. Provide 1 complete spring start-up and a fall shutdown.
- B. Instruct Owner's personnel in operation and maintenance of system, including adjusting of sprinkler heads. Use operation and maintenance material as basis for demonstration.

3.7 SCHEDULES

- A. Perimeter of grassed areas: Pop-up half circle heads.
- B. Corners of grassed areas: Pop-up quarter circle heads.
- C. Within grassed areas: Pop-up full circle heads.
- D. Planters: Fixed square pattern head, and 1 emitter per 4 square feet of planter area.

END OF SECTION

SECTION 32 9200 TURF AND GRASSES

PART 1. GENERAL

1.1 SCOPE OF WORK

- A. Provide labor, materials, equipment and services required to perform the work of seeding as required and as specified herein.
- B. The work of this section includes, but is not limited to:
 - 1. Seed
 - 2. Mulch
 - 3. Fertilizer
 - 4. Maintenance
 - 5. Protection of the Work

1.2 REFERENCES

- A. MnDOT, Minnesota Department of Transportation Standard Specifications for Construction 2018 edition, and its corresponding Supplemental Conditions. Only applicable portions of construction methods and materials apply. Reference to methods of measurement or payment are not applicable.
 - 1. Section 3876 – Seed, 3882 – Mulch Material

PART 2. PRODUCTS

2.1 SEED

- A. Turf Seed Mix shall be MnDOT Seed Mixture 25-131: High Maintenance Turf.
 - 1. Bulk application of seed mix 220lbs. / acre.
- B. Temporary Seed Mixture, if required, shall be a mixture of 20% Perennial Ryegrass and 80% oats (before August 1) or winter wheat (after August 1) by weight. Seeding rates shall be at the rate of 70 pounds per acre.
- C. All seed shall conform to the requirements of the latest seed laws of the State, and shall be properly tagged. Contractor shall pay particular attention to weed seed tolerances. All tags shall be submitted to the Inspector.

2.2 SOD

- A. Sod shall include a maximum of the top 1" of well-established cultured sod consisting of live Kentucky Bluegrass grown on loam soil and free from noxious weeds and relatively free from all other weeds, and free from roots, stones and other objectionable materials. Sod shall resist normal handling without undue breaking or tearing. Sod shall be cut in uniform stripe, 18" minimum width and shall be cut in uniform thickness so a dense root system will be retained but be exposed on the bottom side of the sod. Sod grown on peat will not be accepted.

2.3 MULCH

- A. Mulch for seeded areas with slopes 3:1 or greater than shall be MN DOT Category 1, Straw RD 1S Blanket conforming to MN DOT Specification Section 3885.
- B. Mulch for seeded areas with slopes less than 3:1 shall be Type 5 Wood Fiber Hydro-mulch

conforming to MN DOT 3884. All seeded areas covered with the specified hydro-mulch shall receive an application of 1500 pounds per acre.

2.4 FERTILIZER

- A. Provide fertilizer that is commercial grade and uniform in composition and conforms to applicable state and federal regulations.
- B. A 10-20-10 (NPK) starter fertilizer shall be applied at a rate of 200 lbs. per acre shall be tilled into top two inches of soil prior to all seeding.

PART 3. MAINTENANCE

3.1 MAINTENANCE

- A. Seeding maintenance shall be the contractor's responsibility and continue for a minimum of 60 days after completion of all seeding or until Owner Acceptance. Seeded areas will be accepted when a uniform, healthy, turf cover is established with a maximum distance of 6" between plants.
- B. All water necessary for the completion of this contract shall be supplied by the Contractor or through the irrigation system if applicable. The Contractor shall be responsible for supplying all hose, sprinklers, etc., to do the watering under this contract.
- C. All top-dressing, over seeding, and other corrective materials shall be supplied as needed.
- D. All equipment and services necessary for required mowing shall be supplied as needed.
- E. Sodding maintenance shall include watering, mowing, fertilizing and replacement of dead sod for a minimum of 30 days or until Owner Acceptance.

3.2 PROTECTION

- A. Contractor shall supply materials and services necessary to protect seeding from use during the establishment period, unless provided elsewhere.

PART 4. EXECUTION

4.1 EXECUTION

- A. The seeding subcontractor shall inspect the seed bed to be assured that it is in acceptable condition for seeding. Any final preparations required shall be performed by this contractor.
 - 1. Seed shall be sown by means of a Brillion-type mechanical drill seeder at the rate indicated. Double seeding shall be done in all areas with seeding applied in two passes, each applying 1/2 of the seed. The second pass shall be at a 90-degree angle to the first.
 - 2. Areas where drill-seeding is impractical shall be broadcast seeded. Seed shall be raked or dragged and rolled to firm the soil with a roller of not less than 100 pounds. Mulch shall be applied as specified.
 - 3. Apply the hydro-mulch and straw blanket in accordance with MN DOT Standard Specification 2575.3 and with the manufacturer's recommendations.
- B. This project shall be seeded in the fall no earlier than August 10, no later than September 20 unless approved otherwise by the Landscape Architect.

1. If project schedule does not allow fall seeding, spring seeding shall be done no later than May 15. In that case, maintenance shall be continued until August 30, and include a late-August application of growing season fertilizer.
 2. Between the spring and fall seeding dates, finished grades shall not be left unprotected for more than two weeks. Grades finished between May 15 and July 15 shall be broadcast seeded to 60 pounds per acre of common annual ryegrass and dragged to cover seed. Prior to fall seeding, this cover crop shall be lightly disked.
- C. New growth shall be mowed at a 3-inch height whenever new growth reaches 5 inches in height and prior to final acceptance inspection. At a minimum this will include mowing 3 times. Final mowing shall be at a 2-inch height.

4.2 INSPECTION AND APPROVAL

- A. Initial inspection shall be done jointly by the Landscape Architect and the Contractor at the end of the 60-day maintenance period.
1. Areas failing to show a good stand of grass shall be raked and reseeded. Mulch shall be supplemented as required.
 2. Reseeded areas shall be maintained as specified herein.
- B. Following the initial inspection, the Inspector will arrange for the Owner to assume operation of the irrigation system on the seeded areas.
- C. The Inspector may require an extension of the maintenance period if significant areas are not suitably established.
- D. Final acceptance inspection shall be done jointly by the Landscape Architect and the Contractor at the completion of the establishment period.
1. Removal of temporary protection measures based on acceptability of turf establishment.
 2. Final mowing shall be done after removal of temporary fence, and shall be done at 2-inch height. Excess clippings which may be detrimental to the turf shall be removed.
- E. After final acceptance, Inspector shall arrange for the Owner to assume complete operation and maintenance of the turf.

END OF SECTION

SECTION 32 9300 EXTERIOR PLANTS

PART 1. GENERAL

1.1 SCOPE

- A. This Section includes all labor, material, equipment and related services necessary to furnish and install all plantings, indicated on the Drawings and specified herein.
- B. The work of this Section includes, but is not limited to:
 - 1. Mulching
 - 2. Fertilizing
 - 3. Watering
 - 4. Wrapping
 - 5. Soil Preparation
 - 6. Planting
 - 7. Plant Materials
 - 8. Maintenance
 - 9. Replacement
- C. It is understood that the Contractor has visited and examined the project site, fully understands the existing and proposed conditions, and has made due allowances for them. No additional compensation will be allowed for work required because of the Contractor's failure to do so.

1.2 RELATED SECTIONS

- A. 32 9200 Turf and Grasses
- B. 31 2200 Earthwork

1.3 ALTERNATES

- A. Refer to Specification Section 01 6000 Product Requirements for alternates which may pertain to this Section.

1.4 MATERIALS

- A. Planting Soil for Shrubs: The Contractor shall provide required natural, friable, fertile, fine sandy loam. The topsoil shall be free from subsoil, noxious weeds, stones, lime, cement, ashes, slag or other deleterious matter. Topsoil shall be well drained in its original condition and free of toxic quantities of acid or alkaline elements. It shall contain sand and clay in approximately equal proportions and shall have an organic content by weight of not less than 15% or more than 20% as determined by laboratory tests. The PH shall be between 6 and 7. The Contractor shall submit an analysis of soils along with samples for approval by the Landscape Architect if requested.
- B. Planting soil for Trees: Planting soil shall be a mixture of five (5) parts topsoil and (1) part peat, thoroughly mixed by volume.
- C. Peat: Shall be only moss (sphagnum) peat: Brown acid reaction approximately 4 to 5 ph.; of standard commercial quality delivered to the site in bags or other convenient containers, in air dry condition. Peat shall be fully warranted by the producer.

- D. Mulch: Mulch for trees planted in landscaped areas and shrub beds shall be clean, weed-free shredded hardwood bark mulch material furnished and installed as per details. Solid wood pieces shall be no greater than ½" in width and 3" in length.
- E. Weed Barrier: Non-woven, permeable Pro 5 Weed Barrier by DeWitt (800-888-9669) approved equal.
- F. Fertilizer: Commercial fertilizer shall be Woodace, 16 gram 14-3-3/with Micronutrients Briquettes, or equal.
- G. Water: Shall be furnished by the Contractor for the execution of all work specified in this Contract. The Contractor shall verify that the water available is suitable for irrigation and free from ingredients harmful to plant life.
- H. Tree Wrapping Material: Material shall be first quality 4-inch-wide rolls of bituminous impregnated tape, corrugated or crepe paper, specifically manufactured for tree wrapping, having qualities to resist insect infestation, or similar material as approved by the Landscape Architect.
- I. Plant Labels: Plant labels shall be durable, legible labels stating the correct plant name and size in weather-resistant ink or embossed process. Labels shall be attached in such a manner that will not damage or hinder the growth of the plant to which it is affixed.
- J. Burlap: Burlap used for wrapping root balls of B & B specified trees shall be made of jute and weigh not less than 7.02 ounces per square yard.
- K. Anti-desiccant: Anti-desiccant shall be an emulsion which provides a protective film over plant surfaces permeable enough to permit transpiration, delivered in containers of the manufacturer, and shall be mixed according to the manufacturer's directions ("Wiltpruf") manufactured by Nursery Specialty Products, Inc., Stubbins Road, Groton Falls, New York, or approved equal.

1.5 PLANT MATERIAL STANDARDS

Pursuant to City of Saint Paul resolution 16-171 all plant material and trees for this project shall be from nurseries that do not use neonicotinoids, or other pesticides proven to be harmful to pollinators. The use of neonicotinoid insecticides, and other pesticides proven to be harmful to pollinators, will not be permitted on city grounds. The contractor shall furnish the City with documentation of the source of the plants.

- A. Names and Grades: Plant material shall conform to nomenclature of "Standardized Plant Names: as adopted by the Joint Committee of Horticulture Nomenclature", latest edition. Size and grading standards shall conform to the American Association of Nurserymen, Inc. as published in "American Standard for Nursery Stocks", latest edition. No substitutions of size or grade shall be permitted without written permission from the Landscape Architect. Each bundle of plants and all separate plants shall be properly identified with legible waterproof tags securely fastened to each plant or bundle of plants.
- B. Health: All plants including their roots shall be free from disease, insects, or other injurious qualities. All local, state and federal laws pertaining to the inspection, sale and shipment of plant materials shall be complied with. The trunk bark of all trees shall be sound, trees shall have no large wounds, and any small wounds shall have a satisfactory callus roll formed or forming over them. Plants shall show good annual growth. Buds shall be plump and well filled

for the species. Evergreen foliage shall be good intense color.

- C. Quality: All plants shall be true to type; they shall have normal, well-developed branch systems, and a vigorous fibrous root system; they shall be sound, healthy vigorous plants, free from defects, disfiguring knots, sunscald injuries, abrasions of the bark, plant diseases, insect eggs, borers, and all forms of infestation. All new plants shall be nursery grown. They shall have been growing in similar climatic conditions (north of 39 degrees north latitude) as the location of the Project for at least two (2) years prior to the date of this Contract.
- D. Plant List: The list of plants furnished on the plan is for the information of the Contractor. The height and caliper of trees, the height or spread of the shrubs, the diameter of the balls or roots are the minimum dimensions required. Plants indicated "B&B" are to be dug with a ball of earth and wrapped in burlap.
- E. Balled and Burlapped Stock: All balled and burlapped plants shall conform to the "American Standard for Nursery Stock" latest edition. All balls shall be of natural earth in which the plant has been growing. No manufactured or artificially produced or mudded-in balls shall be accepted. Balls shall be firm and unbroken, and of large enough size to adequately enclose the plant's fibrous root system. Balled and burlapped plants may be rejected due to their failure to meet good digging practices.
- F. Measurements: Shall conform to those specified on the plant list except that oversize plants may be used only after approval by the Landscape Architect. Use of such plants shall not increase the Contract price.
 - 1. Height and spread dimensions indicated refer to the main body of the plant and not from branch tip to branch tip. All trees and shrubs shall be measured when their branches are in normal position. Trees shall have straight trunks with the leader intact, undamaged and uncut.
- G. Inspection: The Contractor shall be responsible for all inspection and approval of plant material that may be required by state, federal and other authorities and he shall secure any permits and certificates that may be required.
 - 1. All plants shall be subject to inspection and approval at place of growth before digging, or upon delivery, for quality, size and variety' such approval shall not impair the right of rejection at the Project site during progress of work, for size, condition of balls, roots, latent defects or injuries. Rejected plants shall be removed immediately from the Project site.
 - 2. Note: Within two (2) weeks after the award of the Contract, documentation shall be submitted to the Landscape Architect, that all plant materials listed on the Plans have been ordered.

1.6 DIGGING AND HAULING

- A. Protection from extremes in exposure and rough handling shall be provided all plant materials during transport and storage.
- B. All plant materials shall be assembled in one location on the job site to permit inspection and approval by the Landscape Architect. The Contractor shall notify the Landscape Architect five (5) working days prior to planting so that a mutually agreeable time may be arranged for the inspection. Stock with broken root balls or loose containers, and stock which shows evidence of being root-bound, overgrown or recently canned, or in the opinion of the Landscape

Architect is damaged or improperly cared for, shall be removed from the site immediately and replaced at the Contractor's expense and with another plant meeting the original specifications. Plants shall not be pruned prior to the approval by the Landscape Architect.

PART 2. PROCEDURE

2.1 TREE PLANTING:

- A. Layout: All trees shall be located as indicated on the Drawings. Where below ground or overhead obstructions are encountered, the trees shall be relocated to new positions as determined by the Landscape Architect.
- B. Planting Pits: Shall be circular with a diameter one (1) foot greater than the diameter of the ball of the tree. The depth of the pit shall be enough to accommodate the ball or roots of the tree when the tree is set to finish grade, allowing for 12 inches of compacted topsoil below the roots of the plant.
- C. Planting Soil Preparation: Mix all components thoroughly before backfilling. Existing soil removed from planting pit shall not be used for backfilling.
- D. Fertilization: All trees shall be fertilized with 16-gram Woodace 14-3-3/with micro-nutrients Briquettes or approved equal. Six briquettes per 1" diameter of trunk up to a maximum of forty (40) briquettes shall be used at a ratio of one (1) briquette in the bottom of the planting per two (2) briquettes around the perimeter of the pit. (Example: 4" diameter tree = 24 briquettes, 8 in bottom of the pit, 16 around sides.) Place appropriate number of briquettes in bottom of pit and over with one inch (1") of planting soil. Add bone meal at a rate of 1/4 lb. per cu. ft. of planting soil and mix thoroughly. Backfill 75% of the soil and evenly place the remaining number of briquettes around the perimeter of the plant, two inches (2") from the roots/ball. Finish backfilling and water. Do not add any additional fertilizer.
- E. Setting of Trees: Before setting the trees, pits shall be backfilled with topsoil to a depth of 12", thoroughly tamped and watered. All plants shall be placed at such a level so that after settlement, the natural relationship between the original grades at which the plant grew, and the present one shall be the same. Trees shall be planted plumb, oriented for desired effect as directed by the Landscape Architect. Topsoil shall be tamped under and around the base of each ball to fill all voids and shall be placed in 6 to 8 inches layers, each thoroughly tamped and puddled. Burlap shall be removed from the sides and top of balls and adjusted to prevent air pockets. No burlap shall be pulled from under the balls. When planting bare root trees, care shall be taken to work topsoil in around the roots and to spread them in a natural position before backfilling. Shallow basin or saucers, a littler larger than the diameter of the ball, shall be formed around all trees to hold additional water.
- F. Mulch: Shredded mulch shall be applied to all tree pits in landscaped areas to a depth of 3 inches (after settlement) as indicated on details. Pull mulch back 3" from plant trunks.
- G. Pruning: All trees shall be neatly pruned after planting in accordance with the best standard practices and as directed by the Landscape Architect. The tree shall be pruned to preserve its natural form and character and, in a manner, appropriate to its particular requirements. In general, at least one third of the deciduous trees shall be removed by thinning or shortening

of branches but no leaders shall be cut. All pruning shall be done with clean, sharp tools, immediately covered with an approved tree paint having an asphaltic base.

- H. Wrapping: All deciduous trees shall be wrapped with material as specified. The wrapping bandage shall be secured at top and bottom of the trunk. The bandage shall cover the entire surface of the trunk to the height of the first branches. Bandaging shall start at the base of the tree unless otherwise specified and be made secure by painting with the approved type tree paint having an asphaltic base which dries and hardens after application.

2.2 SHRUB PLANTING:

- A. Layout: All plants shall be located as indicated on the Drawings.
- B. Planting Pits: Shall have vertical sides. The diameter of the pits shall be twelve (12) inches greater than the diameter of the ball. The depth of the pit shall be enough to accommodate the ball or roots when the plant is set to finish grade compacted allowing for six (6) inches of topsoil below the roots of the plant.
- C. Planting Soil: Remove existing soil to a depth of 8" below finish grades throughout the planting beds and replace with planting soil. Mix all components thoroughly before backfilling. Existing soil removed from planting pit shall not be used for backfilling.
- D. Fertilization: All shrubs shall be fertilized with 16-gram Woodace 14-3-3/with micro-nutrients Briquettes or approved equal. An appropriate number of briquettes as per the manufacturer's recommendation shall be placed in the bottom of the hole and covered with 1 inch of planting soil. Add bone meal at a rate of 1/4 lb. per cu. ft. of planting soil and mix thoroughly. Backfill 75% of the soil and evenly place the remaining recommended number of briquettes around the perimeter of the plant, two inches (2") from the roots/ball. Finish backfilling and water. Do not add any additional fertilizer.
- E. Setting of Plants: All materials shall be planted in the same relation to the finish grade as they had before transplanting. The depth of the holes, as hereafter specified, shall be understood to be the depth below finish grade. Balled and burlapped plants shall have topsoil tamped under the balls. All burlap, ropes, staves, etc. shall be taken off the sides and tops of balls and removed from the hole before backfilling, and no burlap shall be pulled out from under the balls. Roots of bare root plants shall not be left matted together, but shall be arranged in natural positions and shall have topsoil worked in among them. All broken and frayed roots shall be properly removed by trimming.
- F. The Backfill of Topsoil: Shall be tamped in successive 8" layers. When the hole has been 2/3 backfilled, water shall be poured in, filling the hole, and allowed to soak away so that all voids or air pockets under or around the roots are eliminated. After the water has soaked away, the hole shall be completely backfilled with topsoil. After the backfill settles, additional soil shall be filled in, to the level of the finish grade. A shallow saucer of soil shall be formed around the edge of each hole to hold additional water.
- G. Weed Barrier: Apply to all shrub beds.

H. Mulch:

1. Shrubs: Apply shredded hardwood to all beds to a depth of 3" (after settlement). Pull mulch back 3" from plant trunks.

2.3 TEMPORARY STORAGE AND HEELING-IN

- A. When temporary storage or heeling-in is required, the Contractor shall provide and prepare a suitable heeling ground or heeling-in nursery conveniently located near the planting site.
- B. Plant material unloaded and accepted by the Landscape Architect shall be immediately heeled-in or transported to the planting site and planted. Material left out of ground overnight or left with its roots bare to the sun, or otherwise unprotected during transit, unloading, or storage shall be rejected by the Landscape Architect if in his judgment, such lack of protection has caused damage to the roots of the plant or in any other way injured the plant material.

2.4 INSPECTION AND ACCEPTANCE

- A. Inspection of this work will be made by the Landscape Architect at the conclusion of the planting period upon written notice by the contractor at least five (5) days prior to anticipated date. Condition of all plant materials will be noted and recorded for reference.
- B. After inspection, the Contractor will be notified in writing by the Landscape Architect if there are any deficiencies of the requirements for acceptance of the work. After such deficiencies have been corrected, the Landscape Architect will notify the Owner and the Contractor of initial acceptance of the work.

2.5 GUARANTEE, REPLACEMENT AND MAINTENANCE

- A. Trees and shrubs shall be guaranteed for a minimum of one (1) year from the Owner's acceptance of all plant materials contained in the Contract and shall be alive and in satisfactory condition at the end of the guarantee period. Such guarantee excludes vandalism.
- B. At the beginning of each planting season, inspection will be made by the Landscape Architect upon written notice by the Contractor at least five (5) days before the anticipated date. Any tree or shrub that is dead and not showing satisfactory growth, as determined by the Landscape Architect, shall be removed from the site, and any plants or trees missing, excluding vandalism, shall be replaced as soon as conditions permit during the normal planting season. During the planting period or maintenance periods, if a tree or shrub dies the Contractor is to remove the material immediately upon approval by the Landscape Architect.
- C. Where replacements are required, the Contractor will be ordered to furnish and install the replacement plants immediately or at the beginning of the next planting season. All replacements shall meet the landscape planting specifications. It is the intent of these specifications that the initial acceptance establishes the start of the one-year guarantee period. All future replacements are not to be guaranteed for an additional one-year period but are to be guaranteed until the end of the original one-year period.
- D. All replacements shall be trees and shrubs of the same kind and size as specified in the plant list. Replacement costs shall be borne by the Contractor.
- E. The Contractor shall be responsible for all maintenance. This shall include all watering, pruning, tree wrapping, planting soil, rodent protection and other incidental items; of applying insecticide spray as necessary to maintain healthy growth; of furnishing and installing replacement plants as needed, including new mulch and planting soil; of maintaining the

plants in an upright position and or removing all weed growth in the mulched areas, and of performing any other horticultural operations consistent with proper care of the plants. All costs of the plant maintenance shall be at the Contractor's expense, including the replacement material.

2.6 DEFINITION FOR FURNISHING AND INSTALLING PLANT MATERIALS

- A. The unit price contained in the bid proposal for furnishing and installing plant and shrub material shall be defined to include all items in this Section of the Specifications.

2.7 PLANTING SEASON

- A. Planting season shall be in the spring from the time the ground is workable until June 15th and in the fall from the 1st frost until November 1. Contractors wishing to plant outside this planting season shall submit a written request to the Landscape Architect stating reasons for planting out of season, special precautions to be taken and any other pertinent information related to such request. The planting dates for evergreens shall be early spring to June 15 or August 15 to September 15.

2.8 CLEAN-UP

- A. Any soil, manure, peat or similar material which has been brought onto paved areas by hauling operations or otherwise shall be removed promptly, keeping the area clean at all times. Upon completion of the planting, all excess soil, stones, and debris which has not previously been cleaned up shall be removed from the site or disposed of. All ground area disturbed as a result of planting operations shall be restored to their original condition or the desire new appearance.

2.9 PAYMENT

- A. The following items must be completed before payment for any plant material will be approved:
 - 1. All plant material shall be set properly in their pits or beds and fertilized.
 - 2. All plant material shall be mulched.
 - 3. All plant material shall be watered.
 - 4. All plant material, where required, shall be pruned.
 - 5. All dirt, rocks, debris, etc. generated by the digging of planting pits and beds shall be removed from the site on a daily basis.

END OF SECTION

SECTION 33-0600 UTILITY MATERIALS

PART 1 GENERAL

- A. Submittals: Include the following:
 - 1. Product Data for identification materials and devices.
 - 2. Samples of color, lettering style, and other graphic representation for each identification material and device.
 - 3. Shop Drawings detailing fabrication and installation for supports and anchorage for utility piping materials and equipment.
- B. Qualify welding processes and operators for structural steel according to AWS D1.1, "Structural Welding Code--Steel."
- C. Qualify welding processes and operators for piping according to ASME Boiler and Pressure Vessel Code: Section IX, "Welding and Brazing Qualifications."
 - 1. Comply with ASME B31 Series, "Code for Pressure Piping."
 - 2. Certify that each welder has passed AWS qualification tests for welding processes involved and that certification is current.
- D. Comply with ASME A13.1 for lettering size, length of color field, colors, and viewing angles of identification devices.
- E. Comply with governing city, state and federal regulations for utility materials. Comply with hauling and disposal regulations of authorities having jurisdiction.

PART 2 PRODUCTS

- A. Pipe and Fittings: Refer to individual Division 33 Sections for pipe and fitting materials and joining methods. Comply with ASME B1.20.1 for factory-threaded pipe and fittings.
- B. Joining Materials: Refer to individual Division 33 piping Sections for special joining materials not listed below.
 - 1. Pipe-Flange Gasket Materials: Suitable for chemical and thermal conditions of piping system contents.
 - a. ASME B16.21, nonmetallic, flat, asbestos free, 1/8-inch maximum thickness, unless otherwise indicated.
 - 1) Full-Face Type: For flat-face, Class 125 cast-iron and cast-bronze flanges.
 - 2) Narrow-Face Type: For raised-face, Class 250 cast-iron and steel flanges.
 - b. AWWA C110, rubber, flat face, 1/8 inch thick, unless otherwise indicated; and full-face or ring type, unless otherwise indicated.
 - 2. Flange Bolts and Nuts: ASME B18.2.1, carbon steel, unless otherwise indicated.
 - 3. Plastic Pipe-Flange Gasket, Bolts, and Nuts: Type and material recommended by piping system manufacturer, unless otherwise indicated.
 - 4. Solvent Cements: Manufacturer's standard solvent cements for the following:
 - a. ABS Plastic Piping: ASTM D 2235.
 - b. CPVC Plastic Piping: ASTM F 493.
 - c. PVC Plastic Piping: ASTM D 2564. Include primer according to ASTM F 656.
 - d. ABS to PVC Plastic Piping Transition: ASTM D 3138.
 - 5. Plastic Pipe Seals: ASTM F 477, elastomeric gasket.
 - 6. Flanged, Ductile-Iron-Pipe Gaskets, Bolts, and Nuts: AWWA C110, rubber gasket, carbon-steel bolts and nuts.

7. Couplings: Iron-body sleeve assembly, fabricated to match OD of plain-end, pressure pipes.
 - a. Sleeve: ASTM A 126, Class B, gray iron.
 - b. Followers: ASTM A 47 malleable iron or ASTM A 536 ductile iron.
 - c. Gaskets: Rubber.
 - d. Bolts and Nuts: AWWA C111.
 - e. Finish: Enamel paint.
- D. Nonshrink, Nonmetallic Grout: ASTM C 1107, Grade B, post-hardening, volume-adjusting, dry, hydraulic-cement grout of type recommended for exterior applications. Include 5000-psi , 28-day compressive strength.

PART 3 EXECUTION

- A. A. Piping Systems: Install piping as described below, unless piping Sections specify otherwise. Individual Division 33 piping Sections specify unique piping installation requirements.
 1. General Locations and Arrangements: Drawing plans, schematics, and diagrams indicate general location and arrangement of piping systems. Indicated locations and arrangements were used to size pipe and calculate friction loss, expansion, pump sizing, and other design considerations. Install piping as indicated, unless deviations to layout are approved on Coordination Drawings.
 2. Install piping at indicated slopes.
 3. Install components with pressure rating equal to or greater than system operating pressure.
 4. Install piping free of sags and bends.
 5. Install exposed interior and exterior piping at right angles or parallel to building walls.
 6. Locate groups of pipes parallel to each other, spaced to permit valve servicing.
 7. Install fittings for changes in direction and branch connections.
 8. Install couplings according to manufacturer's written instructions.
 9. Verify final equipment locations for roughing-in. Refer to equipment specifications in other Division 33 Sections for roughing-in requirements.
 10. Piping Joint Construction: Join pipe and fittings as follows and as specifically required in individual piping Sections:
 - a. Ream ends of pipes and tubes and remove burrs. Bevel plain ends of steel pipe.
 - b. Remove scale, slag, dirt, and debris from inside and outside pipe and fittings before assembly.
 - c. Soldered Joints: Construct joints according to AWS's "Soldering Manual," Chapter "The Soldering of Pipe and Tube"; or CDA's "Copper Tube Handbook."
 - d. Brazed Joints: Construct joints according to AWS's "Brazing Handbook," Chapter "Pipe and Tube".
 - e. Threaded Joints: Thread pipe with tapered pipe threads according to ASME B1.20.1. Cut threads full and clean using sharp dies. Ream threaded pipe ends to remove burrs and restore full ID. Join pipe fittings and valves as follows:
 - 1) Note internal length of threads in fittings or valve ends, and proximity of internal seat or wall, to determine how far pipe should be threaded into joint.
 - 2) Apply appropriate tape or thread compound to external pipe threads, unless dry seal threading is specified.
 - 3) Align threads at point of assembly.
 - 4) Tighten joint with wrench. Apply wrench to valve end into which pipe is being threaded.
 - 5) Damaged Threads: Do not use pipe or pipe fittings with corroded or damaged threads. Do not use pipe sections that have cracked or open welds.

- f. Welded Joints: Construct joints according to AWS D10.12, "Recommended Practices and Procedures for Welding Low Carbon Steel Pipe," using qualified processes and welding operators.
 - g. Flanged Joints: Align flange surfaces parallel. Select appropriate gasket material, size, type, and thickness for service application. Install gasket concentrically positioned. Assemble joints by sequencing bolt tightening to make initial contact of flanges and gaskets as flat and parallel as possible. Use suitable lubricants on bolt threads. Tighten bolts gradually and uniformly using torque wrench.
 - h. Plastic Piping Solvent-Cement Joints: Clean and dry joining surfaces by wiping with clean cloth or paper towels. Join pipe and fittings according to the following:
 - 1) Comply with ASTM F 402 for safe-handling practice of cleaners, primers, and solvent cements.
 - 2) ABS Plastic Piping: ASTM D 2235 and ASTM D 2661.
 - 3) CPVC Plastic Piping: ASTM D 2846 and ASTM F 493.
 - 4) PVC Plastic, Pressure Piping: ASTM D 2672.
 - 5) PVC Plastic, Nonpressure Piping: ASTM D 2855.
 - 6) ABS to PVC Plastic, Nonpressure Transition Fittings: Procedure and solvent cement according to ASTM D 3138.
 - i. Plastic Piping Heat-Fusion Joints: Clean and dry joining surfaces by wiping with clean cloth or paper towels. Join according to ASTM D 2657 procedures and manufacturer's written instructions.
 - 7) Plain-End Pipe and Fittings: Use butt fusion.
 - 8) Plain-End Pipe and Socket Fittings: Use socket fusion.
 - 11. Piping Connections: Make connections according to the following, unless otherwise indicated:
 - a. Install unions, in piping 2-inch NPS and smaller, adjacent to each valve and at final connection to each piece of equipment with 2-inch NPS or smaller threaded pipe connection.
 - b. Install flanges, in piping 2-1/2-inch NPS and larger, adjacent to flanged valves and at final connection to each piece of equipment with flanged pipe connection.
 - c. Dry Piping Systems: Install dielectric unions and flanges to connect piping materials of dissimilar metals.
 - d. Wet Piping Systems: Install dielectric coupling and nipple fittings to connect piping materials of dissimilar metals.
- B. Install equipment according to approved submittal data. Portions of the Work are shown only in diagrammatic form. Install equipment level and plumb, giving right of way to piping systems installed at required slope

END OF SECTION

SECTION 33-1100 WATER DISTRIBUTION

PART 1 GENERAL

1.1 DESCRIPTION

- A. Comply with "Recommended Standards for Water Work" by the Great Lakes Upper Mississippi River Board of State Public Health and Environmental Managers, 1987 and all subsequent editions.
- B. Comply with City Engineers Association of Minnesota Standard Specifications, 2013 and all subsequent editions.
- C. Provide listing/approval stamp, label, or other marking on piping and specialties made to specified standards.

1.2 SCOPE OF WORK

- A. This work shall consist of the construction of watermain pipe utilizing plant fabricated pipe, hydrants, valves and other appurtenant materials, installed for conveyance of fire and domestic water service.

1.3 GENERAL PROVISIONS

- A. All pipe and materials furnished for watermain installations shall be of the type, kind size and class indicated for each particular line segment as shown in the Plans and designated in the Specifications.

PART 2 PRODUCTS

2.1 WATERMAIN MATERIALS

- A. Pipes and Tubes: Applications of the following pipe and tube materials are indicated in "Piping Applications" Paragraph.
 - 1. Copper Tube: ASTM B 88, seamless water tube, annealed temper.
 - 2. Ductile-Iron, Push-on-Joint Pipe: AWWA C151, with cement-mortar lining and seal coat. Include rubber compression gasket.
- B. Pipe and Tube Fittings: Applications of the following pipe and tube fitting materials are indicated in "Piping Applications" Paragraph.
 - 1. Copper Fittings: ASME B16.22; wrought-copper, solder-joint pressure type.
 - 2. Ductile-Iron, Push-on-Joint Fittings: AWWA C110, ductile-iron or cast-iron; or AWWA C153, ductile-iron, compact type. Include cement-mortar lining, seal coat, and rubber compression gaskets.
- C. Joining Materials: Applications of the following piping joining materials are indicated in "Piping Applications" Paragraph. Refer to Division 2 Section "Utility Materials" for commonly used joining materials.
 - 1. Ductile-Iron Piping: The following materials apply:
 - a. Push-on Joints: AWWA C111 rubber gaskets and lubricant.
- D. Nonrising-Stem, Resilient-Seated Gate Valves, 3-Inch NPS and Larger: AWWA C509, gray- or ductile-iron body and bonnet; with bronze or gray- or ductile-iron gate, resilient seats, bronze stem, and stem nut. Include 200-psig minimum working-pressure design, interior coating according to AWWA C550, and push-on- or mechanical-joint ends.
- E. Valve Boxes: Cast-iron box with top section and cover with lettering "WATER," bottom section with base of size to fit over valve and barrel approximately 5 inches in diameter, and adjustable cast-iron extension of length required for depth of bury of valve. Include steel tee-handle wrench with each valve box.
- F. Indicator Posts: UL 789, FM-approved, vertical-type, cast-iron body with operating wrench, extension rod, and adjustable cast-iron barrel of length required for depth of bury of valve.

- G. Fire Hydrants: WB-67 Waterous, or per City of Minneapolis standards.
- H. Anchorage Materials are as follows:
 - 1. Steel: ASTM A 506, clamps, straps, and washers; ASTM A 575, rods; and ASTM A 307, bolts.
 - 2. Iron: ASTM A 197, malleable-iron rod couplings and ASTM A 126, gray-iron washers.
 - 3. Concrete Reaction Backing: Portland cement concrete mix, 3000 psig; with cement according to ASTM C 150, Type I; sand and crushed gravel according to ASTM C 33; and potable water.

2.2 TRENCHING, BACKFILLING AND COMPACTING

- A. Shall conform to the Drawing and with provisions of Section 31 22 00.

2.3 INSTALLATION OF PIPE

- A. The pipe shall be laid to have a minimum of 7.5 feet of cover.
- B. Install underground piping with restrained joints at horizontal and vertical changes in direction. Use restrained-joint piping, thrust blocks, anchors, tie-rods and clamps, and other supports.
- C. Water-Main Connection: The watermain will be required to be connected to the existing 6" PVC watermain crossing the site.
- D. Install ductile-iron piping according to AWWA C600.
- E. Install anchorages for tees, plugs and caps, bends, crosses, valves, and hydrant branches. Include anchorages for the following piping systems:
 - 1. Gasketed-Joint, Ductile-Iron, Potable-Water Piping: According to AWWA C600.
 - 2. Gasketed-Joint, PVC Potable-Water Piping: According to AWWA M23.
 - 3. Fire-Service Piping: According to NFPA 24.
 - 4. Apply full coat of asphalt or other acceptable corrosion-retarding material to surfaces of installed ferrous anchorage devices.
- F. Valve Installation: Use mechanical-joint-end valves for 3-inch NPS and larger underground installation. Use threaded- and flanged-end valves for installation in pits. Use nonrising-stem UL/FM gate valves for installation with indicator posts. Use bronze corporation stops and valves, with ends compatible with piping, for 2-inch and smaller installation.
 - 1. AWWA-Type Gate Valves: Comply with AWWA C600. Install underground valves with stem pointing up and with cast-iron valve box.
 - 2. UL/FM-Type Gate Valves: Comply with NFPA 24. Install underground valves and valves in pits with stem pointing up and with vertical cast-iron indicator post.
 - 3. Bronze Corporation Stops and Curb Stops: Comply with manufacturer's written instructions. Install underground curb stops with head pointed up and with cast-iron curb box.
- G. Fire Hydrant Installation: Install each fire hydrant with separate gate valve in supply pipe, anchor with restrained joints or thrust blocks, and support in upright position.
 - 1. Install with valve with 7.5 foot bury depth. Provide for drainage.
 - 2. AWWA-Type Fire Hydrants: Comply with AWWA M17.
- H. Conduct piping tests before joints are covered and after thrust blocks have hardened sufficiently. Fill pipeline 24 hours before testing and apply test pressure to stabilize system.
- I. Hydrostatic Tests: Test at 150 pounds per square inch working pressure for 2 hours. Maximum allowable leakage is 3 psi per hour. Remake leaking joints with new materials and repeat test until leakage is within above limits.

J. Disinfecting Mains: After completion of the installation and testing, the CONTRACTOR shall disinfect the new pipe, valves and fittings as described in A.W.W.A. Specification No. C601-68 dated June 1968, by the use of the continuous feed method. The CONTRACTOR may elect to use the table method which is generally described as follows:

1. The CONTRACTOR shall place hypochlorite tablets in each section of pipe and also in hydrants, hydrant branches and other appurtenances during construction. The tablets shall be attached to the top of the pipe with an adhesive of hot tar or "Permatex" No. 2 gasket cement, or other approved material.
2. When the installation has been completed, the main shall be filled with water at a velocity of less than one foot (1') per second. This water shall remain in the pipe for at least 24 hours. After the 24 hour retention period, the heavily chlorinated water shall be flushed from the main until the chlorine concentration in the water leaving the main is less than 1 ppm.
3. Tests are required to determine chlorine residual at the end of the 24 hour retention period and after flushing to ascertain that the heavily chlorinated water has been removed from the pipeline. At the end of the 24 hour retention period, the main shall contain not less than 10 ppm chlorine.
4. The number of tablets required per 18 foot length of pipe based on 3-3/4 grain available chlorine per tablet is as follows:

	<u>Diameter</u>	<u>No. of Tablets</u>
a.	6"	2
b.	8"	3

5. Only fresh disinfectants shall be used and the main filled with water and flushed not later than one week after the disinfectant has been added. The water (containing chlorine) shall be left in the pipe, being disinfected, for a minimum of twenty-four (24) hours. The CONTRACTOR shall take particular care to prevent chlorinated water from entering the existing system.

PART 3 EXECUTION

3.1 ELECTRICAL CONDUCTIVITY TEST

- A. Conductivity tests shall be performed on all DIP mains after they have been pressure tested and are full of water at normal operating pressure. A direct current of 350 amps shall be passed through the line for 4 minutes. Current flow shall be measured continuously on a suitable ammeter and shall remain steady without interruption or excessive fluctuation throughout the period. At the end of the 4 minute period, the current shall be raised to 400 amps for 1 minute without fluctuation. Insufficient current or wide fluctuations of ammeter needle shall be evidence of defective conductivity which shall be isolated, corrected and retested. The connection for the conductivity shall be made either to a gate valve or to the hydrant barrel. Connections shall not be made to any operating mechanism of the hydrant.
- B. Acceptable equipment for the test shall be arc welding machines with adequate sized cables to carry the test current without voltage drop or overheating. Conductivity test shall be carried out in the presence of the ENGINEER or his duly authorized agent. Caution shall be exercised at all times when working with electrical equipment and wires during the conductivity test.

END OF SECTION

SECTION 33-4100 STORM DRAINAGE

PART 1 GENERAL

1.1 SECTION INCLUDES

- A. Storm sewer materials and installation

1.2 RELATED WORK

- A. Section 33-0600 – Utilities Materials

1.3 SUBMITTALS

- A. Submit Shop Drawings for precast concrete manholes, catch basins, and pipes.

1.4 QUALITY ASSURANCE

- A. Provide all imported materials from the same source.
- B. Comply with governing city, state and federal regulations for storm drainage system. Including but not limited to materials, installation, and testing.

PART 2 PRODUCTS

2.1 MATERIAL

- A. Piping:
 1. Reinforced concrete pipe (RCP) and fittings shall conform to the requirements of the Standard Specification for Reinforced Concrete Sewer Pipe, ASTM Designation C76 Wall B with circular reinforcing for the class of the pipe specified.
 2. Corrugated PE Drainage Tubing and Fittings: AASHTO M 252, Type S, with smooth waterway for coupling joints. Watertight Couplings: AASHTO M 252, corrugated, matching tube and fittings to form watertight joints in accordance with the requirements of ASTM D3212. Gaskets shall meet the requirements of ASTM F477.
 3. Corrugated PE Pipe and Fittings: AASHTO M 294, Type S, with smooth waterway for coupling joints. Watertight Couplings: AASHTO M 294, corrugated, matching pipe and fittings to form watertight joints.
 4. Perforated PE Pipe and Fittings: ASTM F 405 or AASHTO M 252, Type CP; corrugated, for coupled joints. Couplings: Manufacturer's standard, band type.
 5. PVC Sewer Pipe and fittings, NPS 15 and smaller: ASTM D 3034, SDR 35, for gasketed joints.
 - a. Gaskets: ASTM F 477, elastomeric seals.
 6. PVC Sewer Pipe and fittings, NPS 18 and larger: ASTM F 679, T-1 wall thickness, bell and spigot for gasketed joints.
 - a. Gaskets: ASTM F 477, elastomeric seals.
 7. Sleeve-Type Pipe Couplings: ASTM C 1173, rubber or elastomeric sleeve and band assembly fabricated to mate with OD of pipes to be joined, for nonpressure joints.
- B. Normal-Traffic Precast Concrete Manholes: ASTM C 478 (ASTM C 478M), precast, reinforced concrete, of depth indicated, with provision for rubber gasketed joints.
 1. Diameter: 48 inches (1200 mm) minimum, unless otherwise indicated.
 2. Ballast: Increase thickness of precast concrete sections or add concrete to base section, as required to prevent flotation.
 3. Base Section: 6-inch (150-mm) minimum thickness for floor slab and 4-inch (100-mm) minimum thickness for walls and base riser section, and having separate base slab or base section with integral floor.
 4. Riser Sections: 4-inch (100-mm) minimum thickness, and lengths to provide depth indicated.

5. Top Section: Eccentric-cone type, unless concentric-cone or flat-slab-top type is indicated. Top of cone of size that matches grade rings.
 6. Gaskets: ASTM C 443 (ASTM C 443M), rubber.
 7. Grade Rings: Include two or three reinforced-concrete rings, of 6- to 9-inch (150- to 229-mm) total thickness, that match 24-inch- (610-mm-) diameter frame and cover.
 8. Steps: ASTM C 478 (ASTM C 478M), individual steps or ladder. Omit steps for manholes less than 60 inches (1500 mm) deep.
 9. Pipe Connectors: ASTM C 923 (ASTM C 923M), resilient, of size required, for each pipe connecting to base section.
 10. Manhole Frames and Covers: ASTM A 536, Grade 60-40-18, ductile-iron castings designed for heavy-duty service. Include 24-inch (610-mm) ID by 7- to 9-inch (178- to 229-mm) riser with 4-inch (100-mm) minimum width flange, and 26-inch- (660-mm-) diameter cover. Include indented top design with lettering "STORM SEWER" cast into cover.
- C. Curb Inlets:
1. Made with vertical curb opening, of materials and dimensions according to utility standards.
- D. Concrete: Cast in place according to ACI 318, ACI 350R and the following:
1. Cement: ASTM C 150, Type II.
 2. Fine Aggregate: ASTM C 33, sand.
 3. Coarse Aggregate: ASTM C 33, crushed gravel.
 4. Water: Potable
- E. Portland Cement Design Mix: 4500 psi (27.6 MPa) minimum, with 0.45 maximum water-cementitious materials ratio.
1. Reinforcement Fabric: ASTM A 185, steel, welded wire fabric, plain.
 2. Reinforcement Bars: ASTM A 615/A 615M, Grade 60 (Grade 400), deformed steel.
- F. F. Ballast: Portland cement design mix, 3000 psi (20.7 MPa) minimum, with 0.58 maximum water-cementitious materials ratio.
1. Reinforcement Fabric: ASTM A 185, steel, welded wire fabric, plain.
 2. Reinforcement Bars: ASTM A 615/A 615M, Grade 60 (Grade 400), deformed steel.
- G. Drainage Course: Narrowly graded mixture of washed crushed stone, or crushed or uncrushed gravel; ASTM D 448; coarse-aggregate grading Size 57; with 100 percent passing a 1-1/2-inch (37.5-mm) sieve and 0 to 5 percent passing a No. 8 (2.36-mm) sieve.
- H. Filter fabric: Type III Geotextile Fabric conforming to Mn/DOT Section 3733.
- I. Protective Coatings: One- or two-coat, coal-tar epoxy; 15-mil minimum thickness, unless otherwise indicated; factory or field applied to the following surfaces:
1. Concrete Manholes: On exterior and interior surfaces.
 2. Manhole Frames and Covers: On entire surfaces.
 3. Concrete Catch Basins: On exterior and interior surfaces.
 4. Catch Basin Frames and Grates: On entire surfaces.

PART 3 EXECUTION

3.1 STORM SEWER

- A. Excavating, trenching, and backfilling are specified in 31-2200 Earthwork.
- B. Piping Applications: Include watertight joints.
 1. 1.NPS 4 and NPS 6 (DN100 and DN150): Corrugated PE drainage tubing and fittings, watertight couplings, and coupled joints.

2. NPS 8 to NPS 15 (DN200 to DN375): Corrugated PE drainage tubing and fittings, watertight couplings, and coupled joints in NPS 8 and NPS 10 (DN200 and DN250). Use corrugated PE pipe and fittings, watertight couplings, and coupled joints in NPS 12 and NPS 15 (DN300 and DN375).
- C. Sleeve-Type Pipe Couplings: Use where required to join piping and no other appropriate method is specified. Do not use instead of specified joining methods.
 - D. General Locations and Arrangements: Drawing plans and details indicate general location and arrangement of underground storm drainage piping. Location and arrangement of piping layout take design considerations into account. Install piping as indicated, to extent practical.
 - E. Install piping beginning at low point, true to grades and alignment indicated with unbroken continuity of invert. Place bell ends of piping facing upstream. Install gaskets, seals, sleeves, and couplings according to manufacturer's written instructions for use of lubricants, cements, and other installation requirements. Maintain swab or drag in line, and pull past each joint as it is completed.
 - F. Use manholes for changes in direction, unless fittings are indicated. Use fittings for branch connections, unless direct tap into existing sewer is indicated.
 - G. Use proper size increasers, reducers, and couplings where different sizes or materials of pipes and fittings are connected. Reducing size of piping in direction of flow is prohibited.
 - H. Install gravity-flow piping and connect to building's storm drains, of sizes and in locations indicated. Terminate piping as indicated.
 1. Install piping pitched down in direction of flow, at minimum slope of 1 percent, unless otherwise indicated.
 2. Install piping with 36-inch (1000-mm) minimum cover.
 - I. Extend storm drainage piping and connect to building's storm drains, of sizes and in locations indicated. Terminate piping as indicated.
 - J. Pipe Joint Construction and Installation: Join and install pipe and fittings according to installations indicated.
 1. PE Pipe and Fittings: Join pipe, tubing, and fittings with couplings for watertight joints according to manufacturer's written instructions. Install according to ASTM D 2321 and manufacturer's written instructions. Install corrugated piping according to the Corrugated Polyethylene Pipe Association's "Recommended Installation Practices for Corrugated Polyethylene Pipe and Fittings."
 2. Reinforced concrete pipe joints shall be Type R-4, and the gasket shall be circular in cross section. Construct the joint in accordance with ASTM C-361.
 3. PVC Sewer Pipe and Fittings: Join pipe and gasketed fittings with gaskets according to ASTM D 2321. Install according to ASTM D 2321.
 4. Join piping made of different materials or dimensions with couplings made for this application. Use couplings that are compatible with and that fit both systems' materials and dimensions.
 - K. Manhole Installation: Install complete with appurtenances and accessories indicated.
 1. Set tops of frames and covers flush with finished surface of manholes that occur in pavements. Set tops 3 inches (76 mm) above finished surface elsewhere, unless otherwise indicated.
 2. Install precast concrete manhole sections with gaskets according to ASTM C 891.
 - L. Catch-Basin Installation: Set frames and grates to elevations indicated.
 - M. Concrete Placement: Place cast-in-place concrete according to ACI 318 and ACI 350R.
 - N. Install drains in locations indicated.
 1. Embed drains in 4-inch (100-mm) minimum depth of concrete around bottom and sides.
 2. Set drain frames and covers with tops flush with pavement surface.

- O. Make connections to existing piping and underground structures so finished Work complies as nearly as practical with requirements specified for new Work.
- P. Make branch connections from side into existing piping, NPS 21 (DN525) or larger, or to underground structures by cutting opening into existing unit large enough to allow 3 inches (76 mm) of concrete to be packed around entering connection. Cut end of connection pipe passing through pipe or structure wall to conform to shape of and be flush with inside wall, unless otherwise indicated. On outside of pipe or structure wall, encase entering connection in 6 inches (150 mm) of concrete for minimum length of 12 inches (300 mm) to provide additional support of collar from connection to undisturbed ground.
 - 1. Use concrete that will attain minimum 28-day compressive strength of 3000 psi (20.7 MPa), unless otherwise indicated.
 - 2. Use epoxy-bonding compound as interface between new and existing concrete and piping materials.
- Q. Protect existing piping and structures to prevent concrete or debris from entering while making tap connections. Remove debris or other extraneous material that may accumulate.
- R. Clear interior of piping and structures of dirt and superfluous material as work progresses. Maintain swab or drag in piping, and pull past each joint as it is completed.
 - 1. Place plug in end of incomplete piping at end of day and when work stops.
 - 2. Flush piping between manholes and other structures to remove collected debris, if required by authorities having jurisdiction.
- S. Inspect interior of piping to determine whether line displacement or other damage has occurred. Inspect after approximately 24 inches (600 mm) of backfill is in place, and again at completion of Project.
 - 1. Defects requiring correction include the following:
 - a. Alignment: Less than full diameter of inside of pipe is visible between structures.
 - b. Deflection: Flexible piping with deflection that prevents passage of ball or cylinder of size not less than 92.5 percent of piping diameter.
 - c. Crushed, broken, cracked, or otherwise damaged piping.
 - d. Infiltration: Water leakage into piping.
 - e. Exfiltration: Water leakage from or around piping.
 - 2. Replace defective piping using new materials, and repeat inspections until defects are within allowances specified.
 - 3. Reinspect and repeat procedure until results are satisfactory.
- T. Test new piping systems according to authorities having jurisdiction.

END OF SECTION